

Table of Content

Description	Page #
1. Safety Operation Rules	2
2. Specifications	4
3. Preparation of Operation	5
4. Electric Circuit, Diagram & Breakdown of Electrical Components	9
5. Operation	15
6. Threading Chart	20
7. Lubrication	22
8. Trouble Cause & Trouble Shooting	25
9. Mechanical Drawings & Parts Breakdown List	26
A. Headstock	27
B. Feed Gear Box & Gear Train Assembly	34
C. Apron	42
D. Saddle, Tool Post & Compound Assembly	48
E. Tailstock-regular	52
F. Tailstock- with rotating spindle	55
G. Bed Sheet Metal & Other Accessories	60
H. Steady Rest	63
I. Follow Rest	65
J. Taper Turning Attachment	67

Important

Do not operate or repair the machine until you have read this manual thoroughly.

Do not operate or repair the machine until you have read appropriate manual!

Note: A safety manual must remain attached to the machine at all time.

SAFETY OPERATION RULES

1. Secure work! Using chuck to secure work piece whenever it is possible! It is safer than using operator's hand and it allows operator to freely operating the lathe using both hands.
2. Do not over-reach! Keep firm footing and balancing at all times.
3. Maintain tools with care! Keep cutting tools sharp and clean for the best and safest operation. Follow instructions for lubricating and changing accessories.
4. Disconnect tools! Before servicing, please make sure accessories such as cutting tools are disconnected.
5. Reduce the risk of unintentional start! Make sure power switch is in "off" position before intentionally plug-in.
6. Use only recommended accessories! Consult owner's manual for recommended accessories. Usage of improper accessories may increase risk and cause injury to operator.
7. Never stand on tool! Serious injury could occur if the tool or cutting tool is tipped or is unintentional contacted.
8. Check damage parts! Before further using cutting tool, guard or other part that is damaged should be carefully checked to determine that it will operate properly, perform its intended function, check for alignment of moving parts, binding of moving parts, breakage of parts, mounting and other conditions that may affect its operation. A guard or other part that is damaged should be replaced or repaired.
9. Never leave cutting tool running unattended. Please turn power off! Do not leave cutting tool until machine comes to a complete stop.
10. Always use safety glasses! Common eyeglasses only have impact resistant lenses. They are NOT safety glasses!
11. Keep guards in place! And keep them in working order.
12. Remove adjusting keys and wrenches! Form habit of double-checking keys and adjusting wrenches are removed from chuck before power on machine.
13. Keep work area clean! Cluttered areas will invite accidents.
14. Don't use power tools in dangerous environments! Do not use power tools in damp or wet location, or expose them to rain. Keep working area well lighted!
15. Keep children away! All visitors should be kept a safety distance from work area.
16. Make workshop child proof! With pad locks, master switches, or by removing starter keys.
17. Do not miss-use tool! Do not force tool or attachment to do a job for which it was not designed for!
18. Use proper tools! Proper tool will do the job better and safer at the rate which it is designed.

19. Wear proper apparels! No loose clothing, gloves, neckties, rings, bracelets, or other jewelry to get caught within machine moving parts. Nonslip footwear is recommended. Wear protective hair covering to contain long hair.
20. Never use machine in high speed over an hour.
21. Keep cutting tools in turning tight during operation!

SPECIFICATIONS

Model	3060G	3080G	30120G	30160G	30200G	30240G
	3360G	3380G	33120G	33160G	33200G	33240G
Capacity						
Center height	385/420mm (15.16"/16.54")					
Max swing over bed	770/840mm (30.31"/33.07")					
Max swing over gap	980/1020mm (38.58"/40.16")					
Max swing over cross slide	500/570mm (19.67"/22.44")					
Distance between centers mm	1600	2100	3100	4100	5100	6100
inch	62.99	82.68	122.05	161.42	200.79	240.16
Main spindle						
Spindle nose	A2-11					
Spindle bore	105/153mm(opt.); 4.13"/6.02" (Opt.)					
Spindle speeds	23~1293RPM/13~690RPM (18 steps)					
Carriage						
Max slide travel	450mm (17.72")					
Compound rest travel	250mm (9.84")					
Tailstock						
Tailstock spindle diameter	105mm (4.13")					
Tailstock spindle travel	220mm (8.66")					
Tailstock spindle taper	MT#5					
Bed						
Bed width	450mm (17.72")					
Threading						
Leadscrew	2 TPI or 12mm/pitch					
Metric pitch threads	0.08~14mm/pitch (65 kinds)					
Inch threads	2~28 TPI (36 kinds)					
Module pitch threads	0.5~7M (22 kinds)					
DP threads	4~56/TPI (36 kinds)					
Feeding range						
Range of longitudinal feeds	0.05~0.7mm/rev.					
Range of cross feeds	0.025~0.35mm/rev.					
Motor						
Main spindle	15/20HP (Opt.)					
Rapid feed motor	1/4HP					
Coolant pump	1/8HP					
Net weight approx.						
30" series kgs	3350	3600	4100	4600	5100	5700
lbs	7370	7920	9020	10120	11220	12540
33" series kgs	3450	3700	4200	4700	5200	5800
lbs	7590	8140	9240	10340	11440	12760

Preparation for operation

Notes before operation

Unpacking:

After unpacking the transportation wooden crate, please inspect the machine carefully. If there is any shortage or damage, please contact your local dealership immediately.

Moving & lifting

Moving & lifting the machine by using a special hang fixture as figure 1 (page 7) shown and insert the special hang fixture into the gap center of the machine bed.

Raising and lowering the machine should be careful. Do not touch the leadscrew, spindle or handwheels, etc. Be careful; do not bump the machine against the floor!

Before moving, please check the following areas:

1. Lock and clamp the tailstock.
2. Lock the saddle lock.
3. Engage half-nut with leadscrew.

Foundations:

Due to the cutting speed and spindle speed are much higher than before, an incomplete foundation will generate vibration and unstable cutting condition.

Please have the foundation done as figure 2 (page 8) shown. Enough space and boundary are necessary. Machine should be installed at least three feet from the wall and other machines.

Leveling the machine:

Anchor bolts and installation blocks must be located steadily into the concrete mix. For alignment of the machine, please place the square precision level on the guideway of the bed (the preciseness of the level is 0.02/100mm or better) and measuring the level of the bed way from left to right, front to back and adjust the leveling bolts until the sensitivity is within 0.04/100mm.

After the leveling procedure is completed, please fasten the foundation nuts. If the flatness deviates when locking foundation nuts, then readjustment of the level is required. Please repeat the procedure until all nuts are tightened.

Clean up

Cosmoline was applied on the machine before transportation. For cleaning up the bed, slideways and leadscrews etc., we can use solvent such as WD 40 to clean off the cosmoline. Please do not use lacquer, varnish, or kerosene! Apply

lubrication oil to all the necessary areas. Check all the handles and levers to see if they are functioning normally, and then set them to neutral positions.

Electrical power connections:

Electrical cabinet is provided at the rear lower part of the headstock. In it, there is a panel with all the electrical components, transformers, and fuses, etc. We also provide the electrical diagram at following pages.

Cautions:

After power connection, please check spindle rotation, using the jogging switch and power on/off lever. If it rotates in counter-clockwise, the wiring is correct. If it is not, please switch two wire terminals at RST position. And then check the rotation again. Spindle rotation must be correct before machine operation.

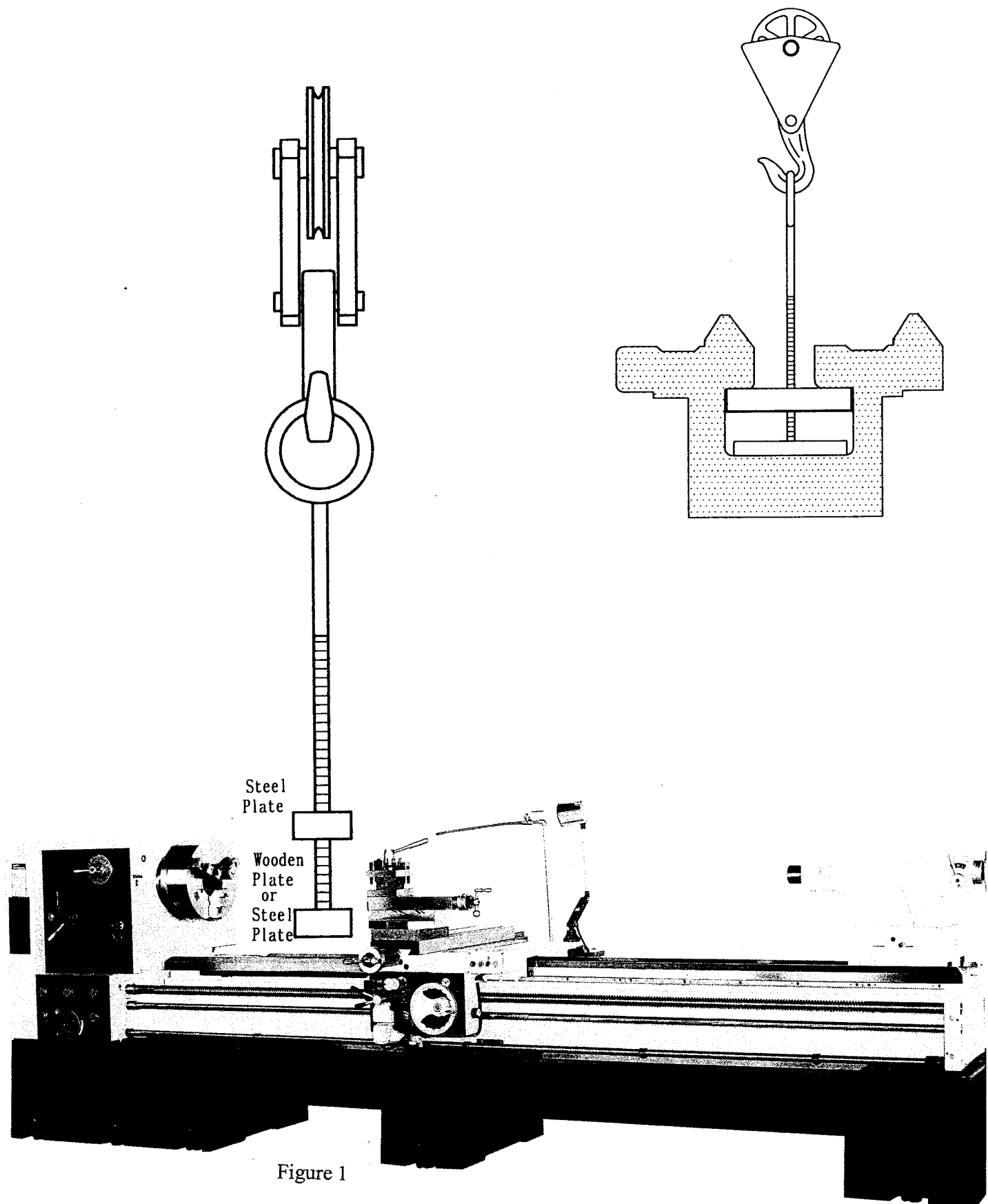

Figure 1

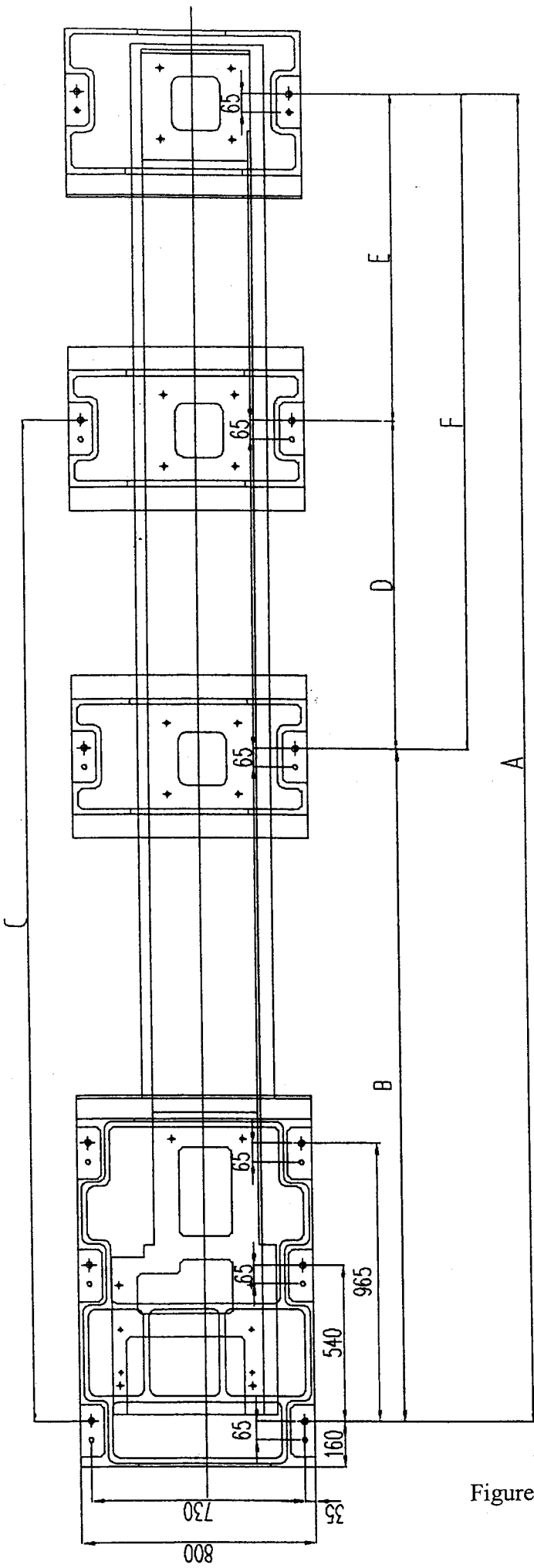
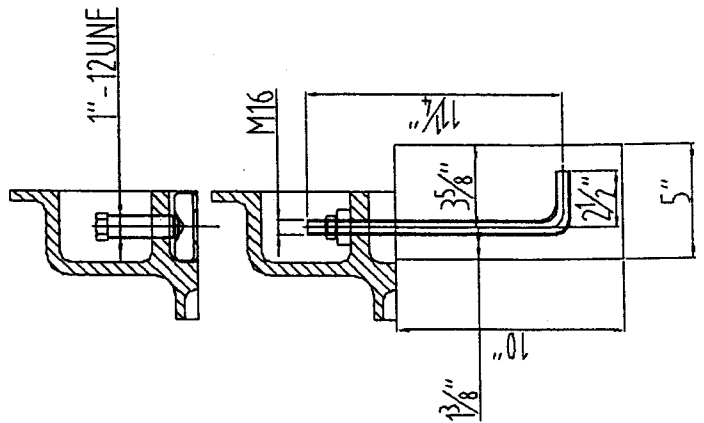

Figure 2

FOUNDATION DRAWING

D.B.C	A	B	C	D	E	F
1500MM(60")	3080					
2000MM(80")	3580					
3000MM(120")	4580	2335				2245
4000MM(160")	5580	3335				2245
5000MM(200")	6580	2835	4335	1500	2245	
6000MM(240")	7580	3315	5315	2000	2265	4265



Electric Circuit, Diagram
&
Breakdown of Electrical
components

04-12-2010

Electric Diagram

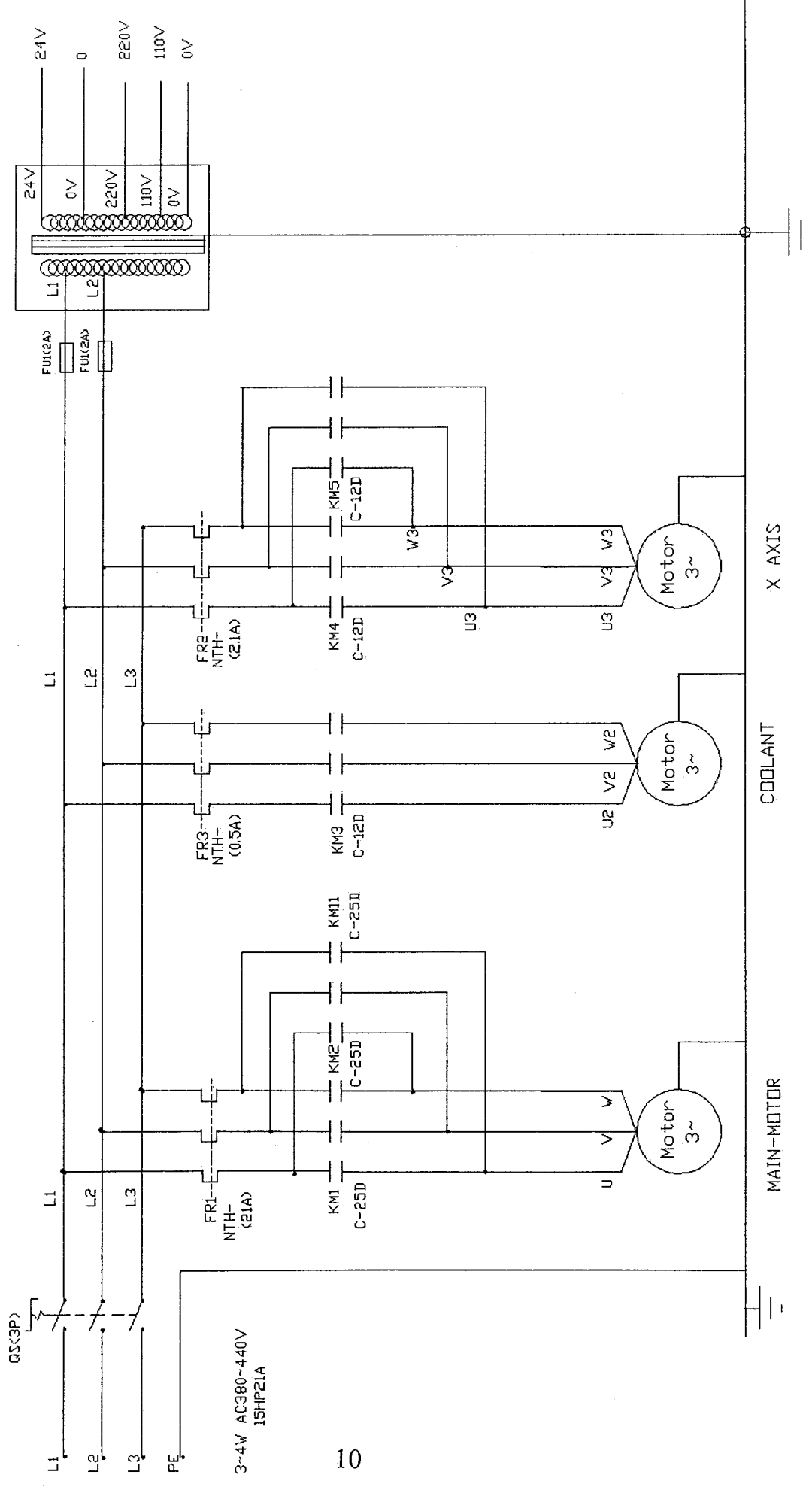

3~4W AC380-440V
15HP21A

Control Circuit

04-12-2010

(Cover-Sw)

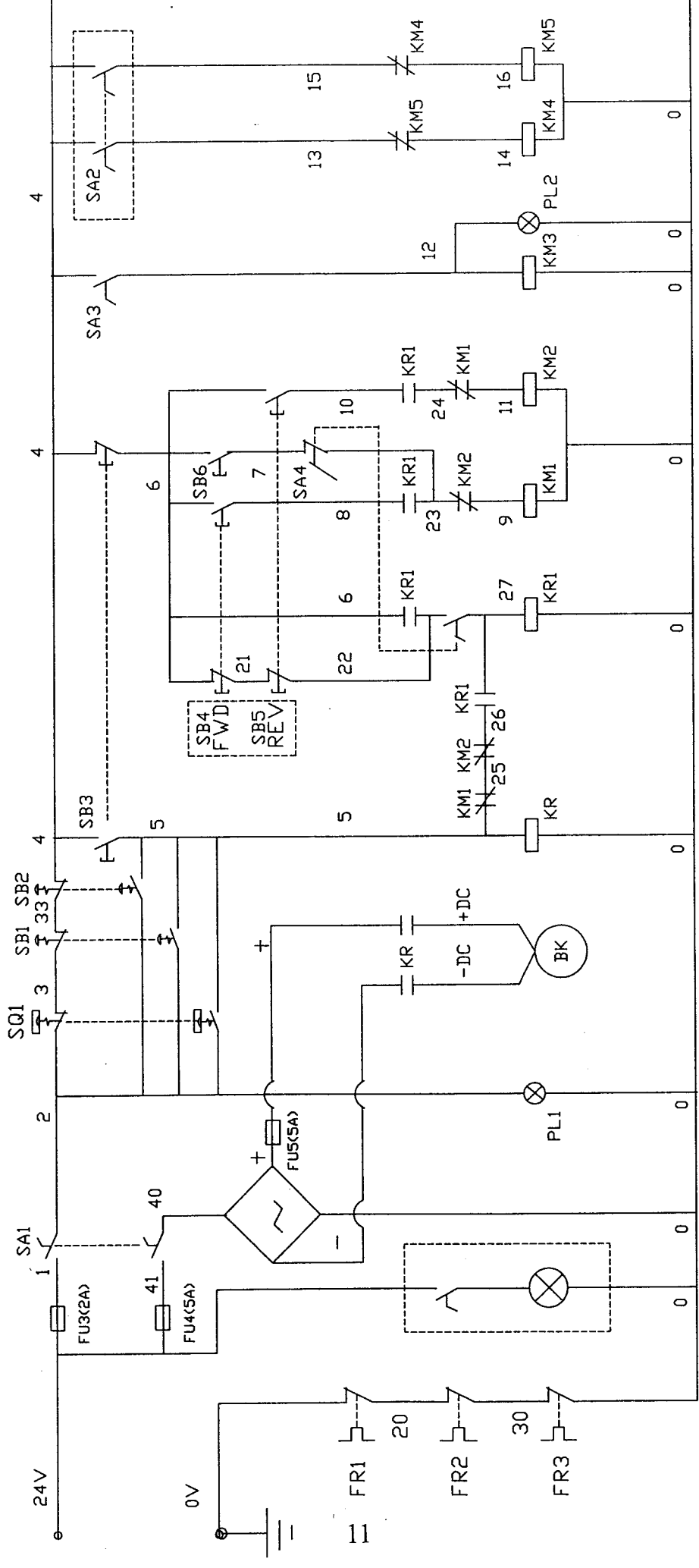

- 0 WORK LAMP
- 0 START LAMP
- 0 ELECTRICAL BREAKER
- 0 BRAKE RELAY
- 0 RUN RELAY
- 0 FWD
- 0 REV
- 0 COOLANT
- 0 LEFT
- 0 RIGHT

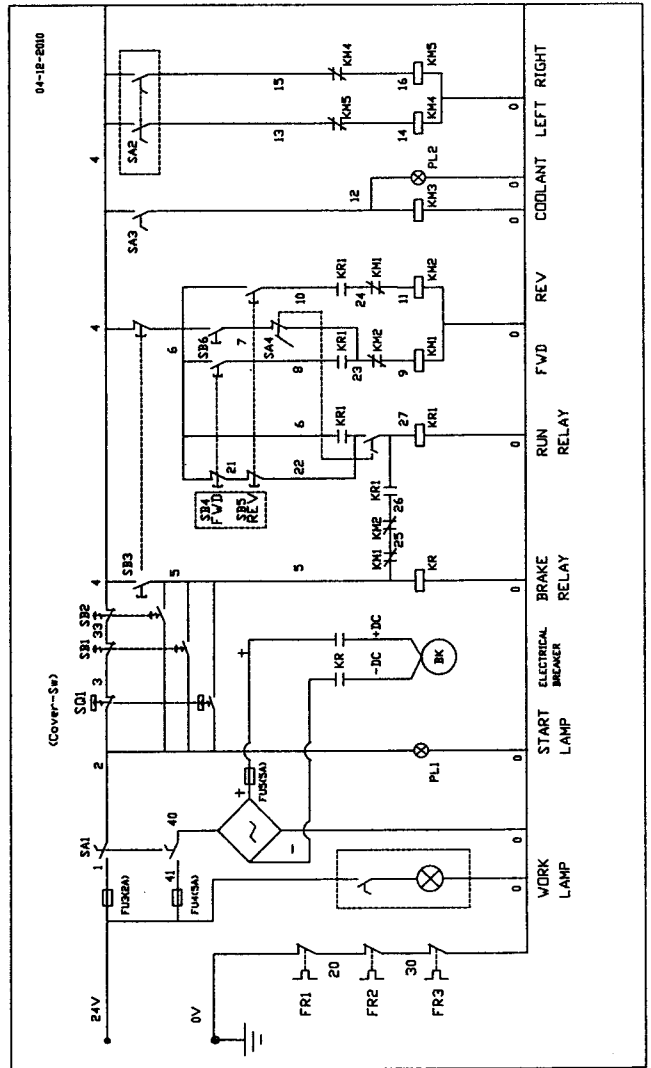
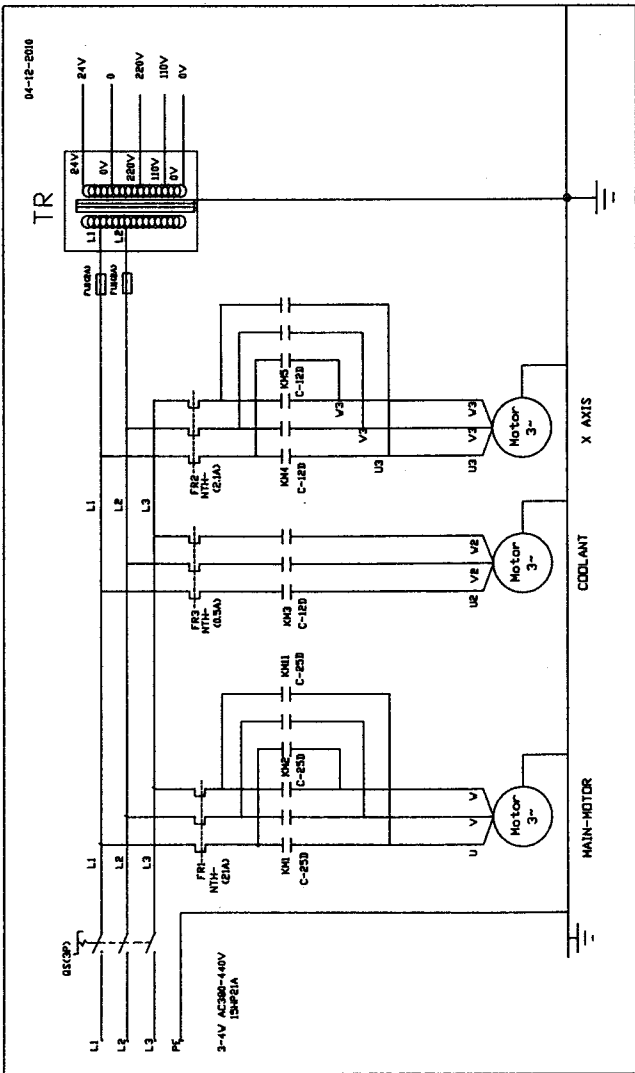
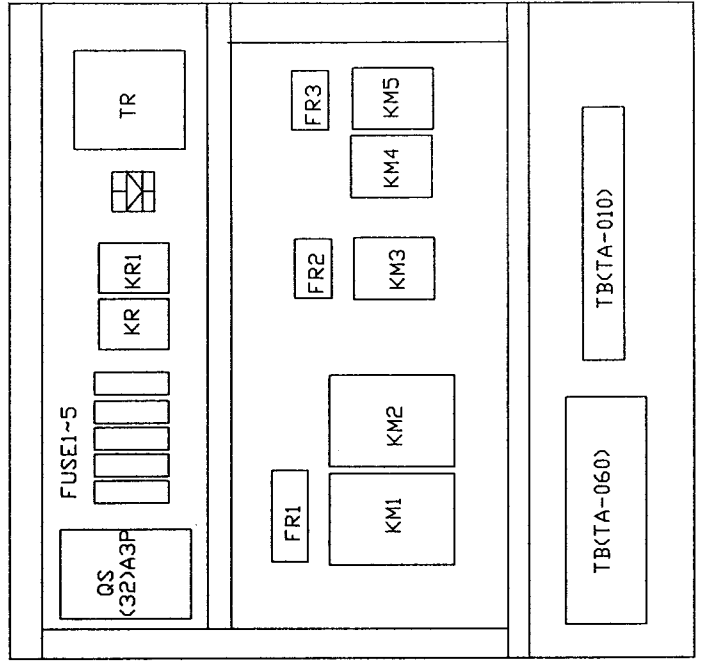
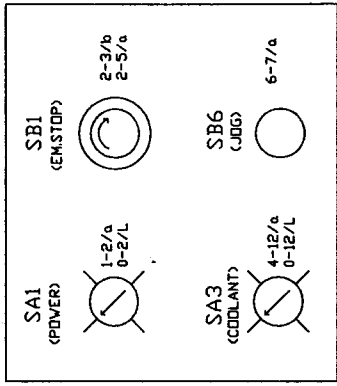

Lay-out of Electric Cabinet

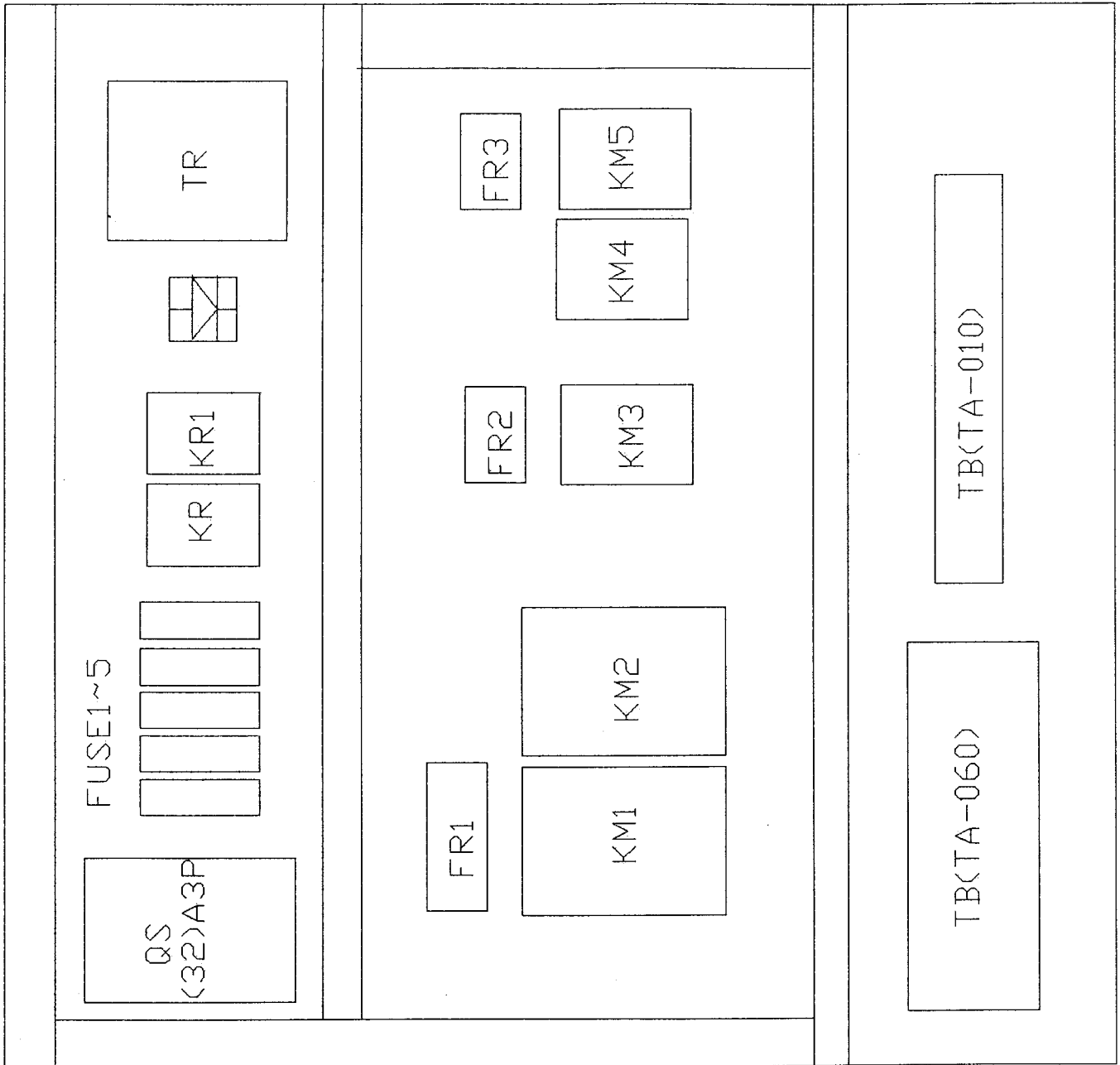

Electrical Component List

Manufacturer		SCHEDULE OF ELECTRICAL EQUIPMENT			Sheet	
Order					2010-04-12	
LATHE MACHINE: CE(+字機) + Fast 15HP			See also list		Drawn	Louis
					Checked	
Item	Description and function	Technical data	Quantity	Supplier	Suppliers reference	
QS	DOOR-LOCK	AC 600V 3P 32A	1	S.E.C	ZH-C332	
FU1	AC FUSE	AC 600V	1	SHINING	FS-011	
FU2	TO TRANSFORMER	30mm 3A	1	SHINING	FS-011	
FU3	AC Low Voltage to Countrol	AC 600v 30mm 5A	1	SHINING	FS-011	
FU4	AC Low Voltage to Brake	AC 600v 30mm 5A	1	SHINING	FS-011	
FU5	DC Low Voltage to Brake	AC 600v 30mm 5A	1	SHINING	FS-011	
KM1	Main-Motor(For)	3Pia Ri=AC660V Rt=50A	1	N.H.D	C-35D	
KM2	Main-Motor(Rev)	AC3 220V 11kW 380V 19kW Coil AC 24V	1		C-35D	
KM3	Coolant-Pump	3Pia Ri=AC660V Rt=25A Coil AC 24V	1	N.H.D	C-12D10	
KM4	Fast-Motor(For)	3Pia Ri=AC660V Rt=25A	1	N.H.D	C-12D	
KM5	Fast-Motor(Rev)	AC3 220V 4kW 380V 7.5kW Coil AC 24V	1		C-12D	
KR	Control-Relay	AC 7A 250V Coil AC 24V	1	ARITA	MR-2P	
KR1			1		MR-4P	
FR1	Over-Load (Main-Motor)	Ui=AC 600V 21A~25A/21A	1	N.H.D	NTH-25	
FR2	Over-Load (Coolant-Pump)	Ui=AC 600V 0.35A~0.5A/0.5A	1	N.H.D	NTH-0.5	
FR3	Over-Load (Move-Motor)	Ui=AC 600V 1.8A~2.5A/2.1A	1	N.H.D	NTH-2.5	
TR	Transformer	AC Hi=380v~440V AC LO=24V	1	S.L	TR(4-0)	
SB1	Power Selector Switch	AC 250V 10A	1	MACK	MK/CF-30	
SB2	Emergency-Stop	MAX.600V	1		MK/B-30	
SB2-1	Emergency-Stop	1NO*1NC Lamp AC 24V 1.5W	1		MK/B-30	
SB3	Jogging-Botton		1		MK/BF-30	
SB4	Pump-Selector		1		MK/C-30	
SB6	Move-Selector		1		MK/C-30	
SB5	Runway-Selector Monolever switch	AC 250V 6A MAX.600V	1	TEND	TMR-302	
SQ1	Cover-Limit.Switch	AC 125V 10A 250V 10A MAX.600V	1	C.T	CT-1701	
SQ4	Foot-Cut (L.s)	AC 125V 10A 250V 10A MAX.600V	1	C.T	CT-1704	

OPERATION

- | | | |
|--|---------------------------------------|---------------------------------------|
| 1. Headstock | 15. Threading Indicator
Dial | 32. Feed Selector |
| 2. Feed Gear Box | 16. Carriage Lock | 33. Feed Selector |
| 3. Apron | 17. Lead Screw | 34. Feed Selector |
| 4. Tailstock | 18. Feed Bar | 35. Engage Lever |
| 5. Spindle Speed
Selector | 19. Spindle Control Lever | 36. Hand Oiler |
| 6. Hi, Middle & Low
Speed Selector | 20. Quill Lock | 37. Feed Strength
Regulating Knob |
| 7. Feed Direction
Selector | 21. Coolant Pipe | 38. Longitudinal Kick-out
Device |
| 8. Feed Selector | 22. Jogging Switches | 39. Stopping Bar |
| 9. Oil Level Sight
Window | 23. Brake Pedal | 40. Carriage Lock
Capscrew |
| 10. Emg. Stop Swittches | 24. Power Switches | 41. Rapid Feed Switches |
| 11. Longitudinal
Transverse Handwheel | 25. Coolant Pump Switches | 42. Power Feed Motor |
| 12. Cross Feed Handle | 26. Foundation Bolts | 43. Rapid Longit/Cross
Feed Handle |
| 13. Longitudinal/Cross
Feed Selector | 27. Quill Transverse
Handwheel | 44. Oil Feed Regulator |
| 14. Thread Cutting
Engagement Lever | 28. Cap | |
| | 29. Feed Selector | |
| | 30. Longitudinal-Cross
Feed Clutch | |
| | 31. | |

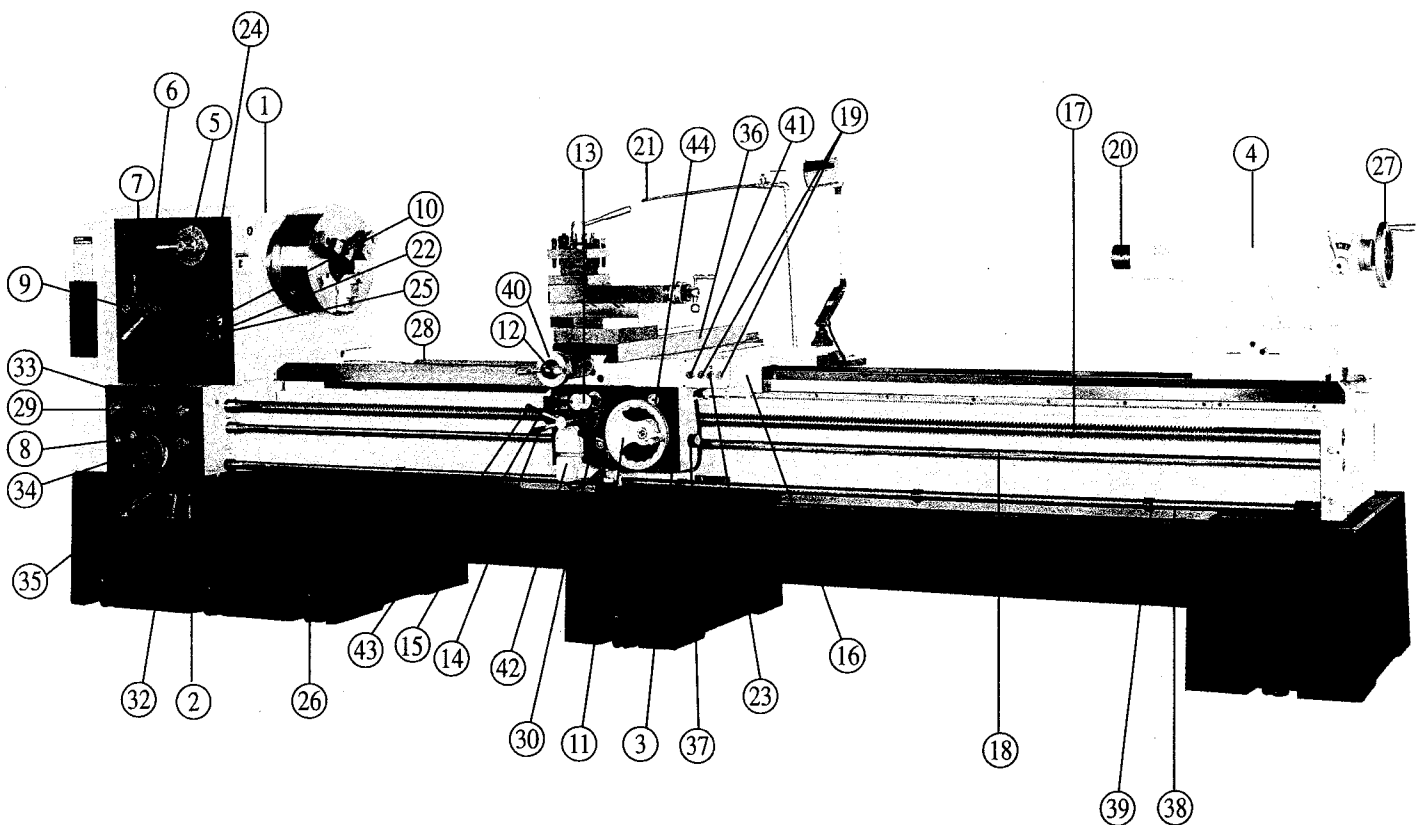

SPINDLE SPEED SELECTION, STOP & RESTART: (CONVENTIONAL / BRAKE & CLUTCH)

The first turn on the power source switch and then, set the feed direction selecting lever ⑦ at neutral position, set the spindle speed change lever ⑤ to the desired speed rate and set hi-low speed selecting lever ⑥ to either high or low position, after that, push on the spindle For/Rev button ⑨ which will caused the spindle rotates in counter-clockwise or in clockwise direction. (speed selecting can be refered as table 1).

As for to stop the spindle rotation which can be employed the emg. stop button ⑩ .

After the spindle be stopped and want to restart the spindle rotation, which must pushed on the For/Rew button ⑨ , and then, followed by the selection of forward/reverse direction.

CAUTIONS:

- If want to change the spindle speed which must be stopped the spindle rotating, otherwise, the gear of headstock will will be damaged.
- If it is hard to set the lever on position when making speed chn ange, we can pust the jogging switch ⑪ slightly.

HOW TO OPERATE THE JOGGING SWITCH:

During in operating, if we want to make speed change more easier or adjusting the center for chucking raw material when four jaws chuck is used. and then, we can employed couple with the jogging switch ⑪ .

GEAR CHANGE SYSTEM:

The gear change system is located at the left side of the headstock as fig shown, please refer to thread cutting as table 1).

CAUTIONS:

- Don't attempt to change gears when the spindle is running.

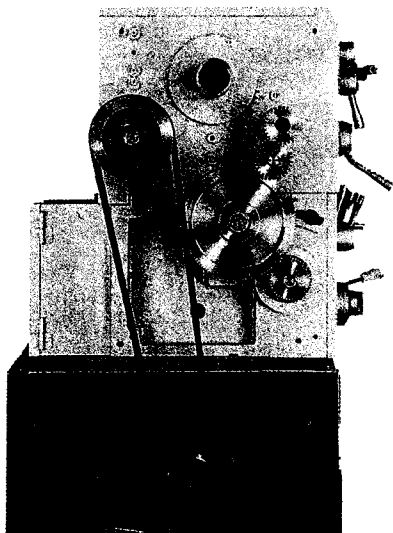

Speed Range		1	2	3
H	I	395	523	690
	II	200	263	347
M	I	86	115	150
	II	44	58	76
L	I	26	33	45
	II	13	17	23

Table 1

HOW TO OPERATE THE CARRIAGE & APRON:

For longitudinal feed push down the longitudinal-cross feed selector ⑬, But for cross feed, which will pull up the selector ⑬ and refer table 2)。

MANUAL FEED:

Carriage moves longitudinally by turn the longitudinal traverse handwheel ⑪, meanwhile, set the feed direction selecting lever ⑦ the thread cutting engaging lever ⑭ at neutral position and pull up the long-cross feed selector ⑬ up (one graduation of handwheel dial is corresponding to 0.002" and one turn also corresponding to 0.4" travel of carriage.)

AUTO FEED:

The auto feed is operated as following procedures:

1. Select the feed direction by feed direction selecting lever ⑦
2. Set gear change and shift levers ⑧ & ⑩ to desired feed rate
3. Shift auto feed clutch lever ⑬ to feed direction
4. Pull the thread cutting engaging lever ⑭ up
5. Turn the longitudinal-cross selecting lever to either longitudinal or cross feed position
6. Shift the spindle start lever ⑲ to forward direction
7. When the auto feed clutch lever ⑬ shifted and the auto feed will be processed. But the auto feed clutch lever ⑬ is shifted to the neutral position and the feed will be stopped followingly.

SWIVELLING THE TOOL POST:

If want making swivelling the tool post which must loosen tool carriage lock capscrew ④⑩ before.

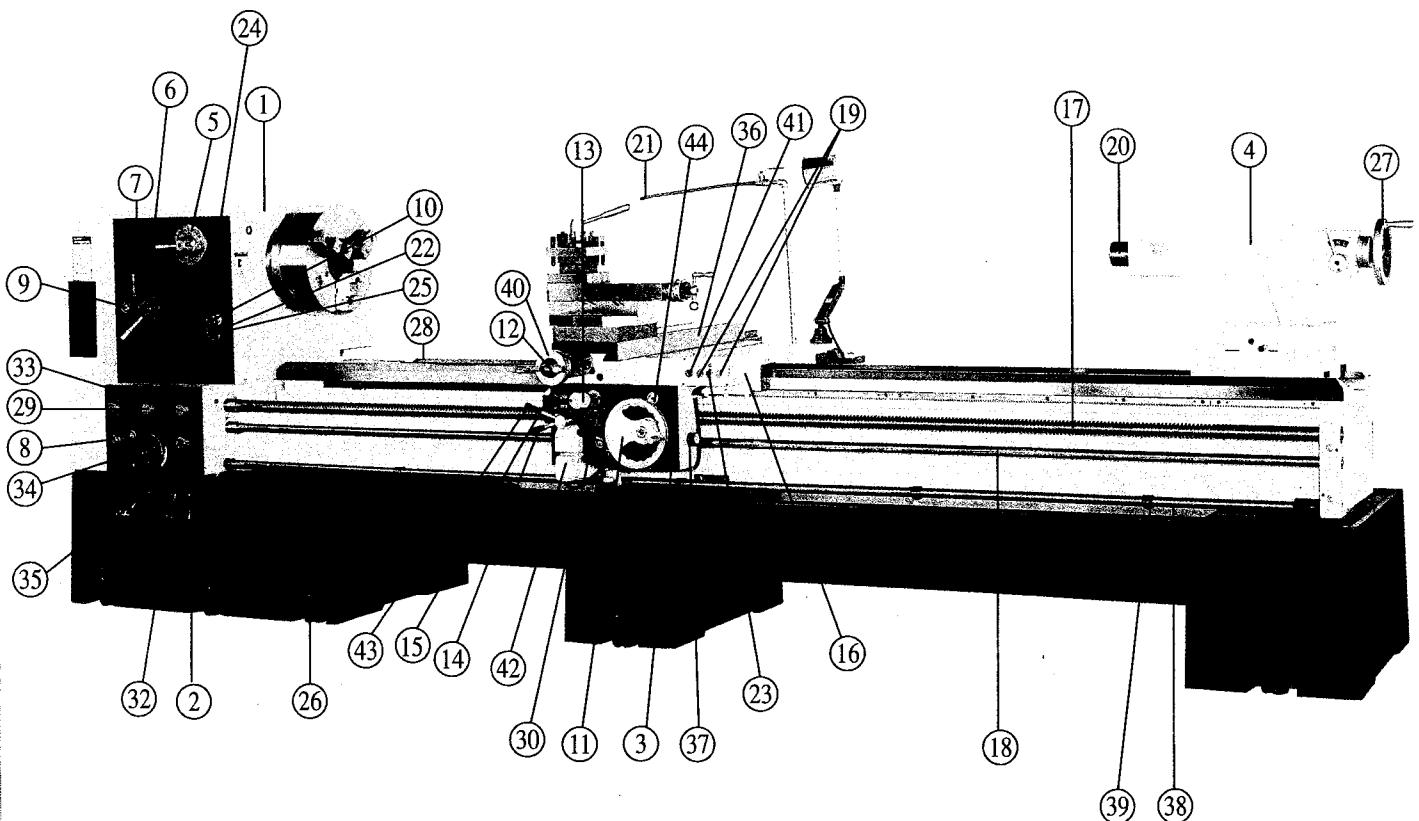

LEVER	 MM ($\frac{1}{2}$)								
	1	2	3	4	5	6	7	8	9
ACMG	0.40	0.44	0.46	0.48	0.52	0.56	0.60	0.62	0.70
BCMG	0.20	0.22	0.23	0.24	0.26	0.28	0.30	0.31	0.35
ADMG	0.10	0.11	0.11	0.12	0.13	0.14	0.15	0.16	0.17
BDMG	0.05	0.05	0.05	0.06	0.06	0.07	0.07	0.08	0.09

Table 2

HOW TO OPERATE THE TAILSTOCK:

There is a center fixed in the sleeve of MT#4 and aligned with the center-line of the headstock, The sleeve can be moved by rotating the handwheel, One graduation of handwheel dial is corresponding to 0.002" and one turn also corresponding to 0.2" travel of tailstock spindle, the total range of movement of the sleeve is 130 mm.

In order to accommodate to the length of the workpiece, the tailstock can slide along the bed way by pushing or pulling it to the required position and then, locked it by lifting the tailstock clamp lever up till tighten.

THREADING CHART

LEVER	W FOR CUTTING INCH THREAD								
	1	2	3	4	5	6	7	8	9
ADWF	2	2-1/4	2-3/8	2-1/2	2-3/4	2-7/8	3	3-1/4	3-1/2
BDWF	4	4-1/2	4-3/4	5	5-1/2	5-3/4	6	6-1/2	7
ACWF	8	9	9-1/2	10	11	11-1/2	12	13	14
BCWF	16	18	19	20	22	23	24	26	28
LEVER	M FOR CUTTING METRIC THREAD								
	1	2	3	4	5	6	7	8	9
ACME	8	9	9.5	10	11	11.5	12	13	14
BCME	4	4.5	4.75	5	5.5	5.75	6	6.5	7
ADME	2	2.25	/	2.5	2.75	/	3	3.25	3.5
BDME	1	/	/	1.25	/	/	1.5	/	1.75
ACMH	6.4	7.2	7.6	8	8.8	9.2	9.6	10.4	11.2
BCMH	3.2	3.6	3.8	4	4.4	4.6	4.8	5.2	5.6
ADMH	1.6	1.9	1.9	2	2.2	2.3	2.4	2.6	2.8
BDMH	0.8	0.9	0.95	1	1.1	1.15	1.2	1.3	1.4
LEVER	W FOR CUTTING DP THREAD								
	1	2	3	4	5	6	7	8	9
ADWF	4	4-1/2	4-3/4	5	5-1/2	5-3/4	6	6-1/2	7
BDWF	8	9	9-1/2	10	11	11-1/2	12	13	14
ACWF	16	18	19	20	22	23	24	26	28
BCWF	32	36	38	40	44	46	48	52	56
LEVER	M FOR CUTTING MODULE THREAD								
	1	2	3	4	5	6	7	8	9
ACME	4	4.5	4.75	5	5.5	5.75	6	6.5	7
BCME	2	2.25	/	2.5	2.75	/	3	3.25	3.5
ADME	1	/	/	1.25	/	/	1.5	/	1.75
BDME	0.5	/	/	/	/	/	0.75	/	/

HOW TO OPERATE THE LEADSCREW:

When shift the feed direction selecting lever ⑦ to the right or left and so as to the leadscrew will run forward or reverse rotating respectively.

INCH THREAD SYSTEM:

The inch thread cutting is operated as following procedures:

- 1.The gear change are aligned for ready making inch threading cutting.
- 2.Thus, shift levers ⑧,⑩,⑳ to the desired position and shift lever to one of 8 position.
- 3.Shift spindle start lever ⑲ downward to the forward rotating direction.
- 4.Shift thread cutting engaging lever down (half nut engaged) to start thread cutting.

THREAD CUTTING INDEXING:

The thread cutting indicating is installed on the headstock panel which has eight graduation. For making inch thread cutting. the thread cutting indexing will be prepared to correct position of half nut engaging quickly and conveniently.

As for the metric thread cutting, the half nut should be engaged with lead screw completely (when the leadscrew is in inch)

Which let tool post back to start position by spindle reversing rotating and then, feeding engaging again, when making metric thread cutting using leadscrew of imperial system or vice versa, the thread cutting engaging lever has to maintain engaged until to the end of thread cutting process.

INCH SYSTEM (LEADSCREW 4T.P.I)

T.P.I.	DIVIDE	WORM
4 8 12 16 20 24 28 32 36 40 44 48 56	16	16
6 10 14 18 26	8	
5 7 9 11 13 19	4	
4 1/2 5 1/2 6 1/2 9 1/2	2	

LUBRICATION

LUBRICATION IN HEADSTOCK & FEED GEAR BOX:

Those are oil bath lubricated for both gear box and headstock, please always beware the oil level is not lower than the minimum level of oil window.

LUBRICATION IN GEAR CHANGE SYSTEM:

Open the protecting cover of gear change system and dip the lubricating oil with drop oiler daily.

LUBRICATION IN CARRIAGE & TOOL POST:

Carriage slides lubricated by hand oil pump and the tool post lubricated with drop oiler daily before starting the machine.

LUBRICATION IN APRON:

The apron itself is served as an oil reservoir, it's rotating parts are dipped into the oil bath, and the other parts are lubricated by splashing. Be sure the oil on proper height of oil window.

LUBRICATION IN BEDWAY, LEADSCREW, & LEADSCREW POST:



The bed way, leadscrew and leadscrew post which must lubricated with drop oiler oftenly due to operating condit

FLUID COOLANT FOR CUTTING:

The coolant pump will be employed when the machining work is running and push on the coolant pump switch ④.

LUBRICATION OIL:

- | | | |
|---|-------------|--------------|
| 1. HEADSTOCK & FEED GEAR BOX | | |
| MOBIL | ESSO | SHEEL |
| D.T.E HEAVY MEDIUM | TELLESSO 52 | FELLUS 32 |
| 2. APRON, COMPOUND, TAILSTOCK, LEADSCREW, SLIDE WAYS AND CARRIAGE SCREW | | |
| MOBIL | ESSO | SHEEL |
| VACTRA NO.2 | FEHIS K-53 | TONNA OIL 27 |
| 3. CHANGE GEARS GREASE | | |

			
Service Interval	Daily	When required	Up oil level Window oftenly

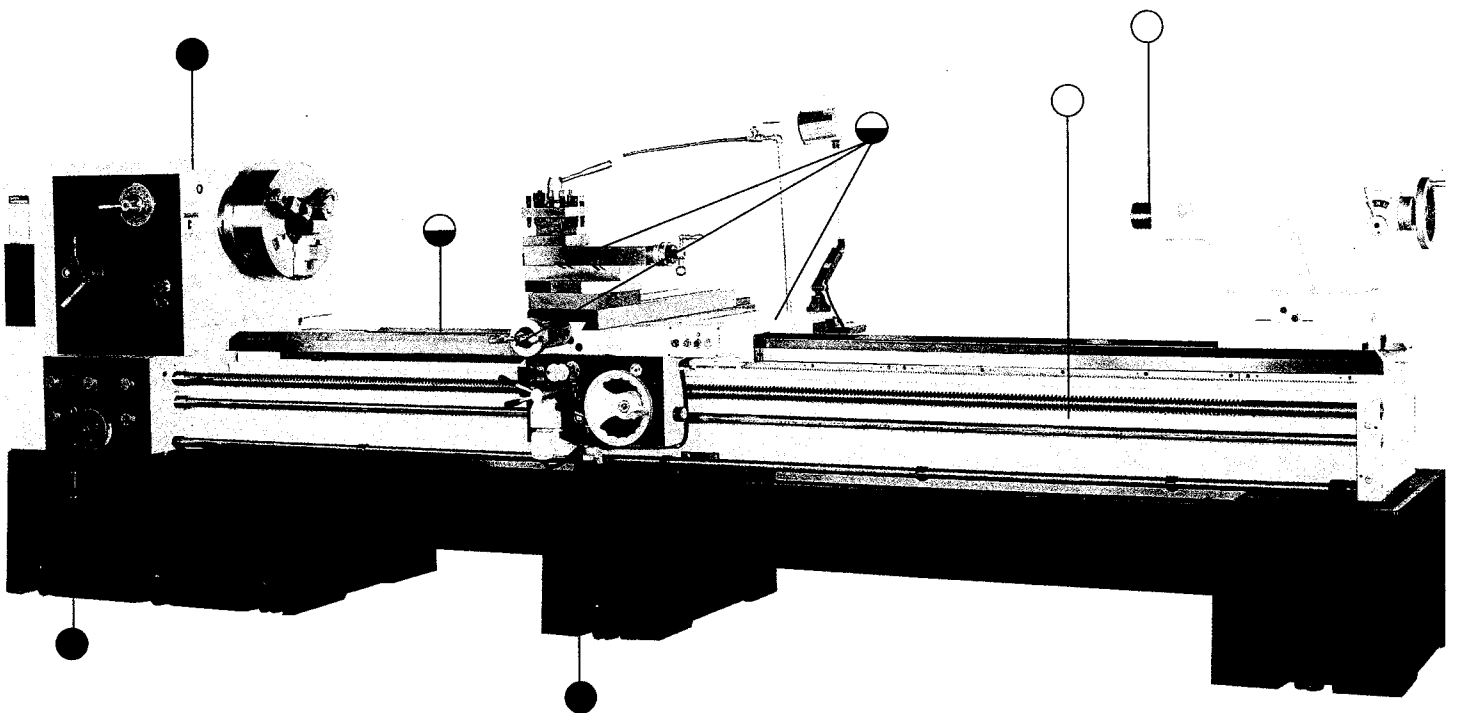
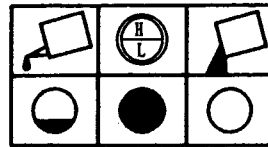

TROUBLE CAUSE & TROUBLE SHOOTING

TROUBLE ITEM	CAUSE	REMEADY
Vibration	<p>Loose levelling screws</p> <p>Torn or mismatched Vee belts</p> <p>Work or chuck out of balance operating at high spindle speed.</p> <p>Motor out of balance</p>	<p>Set all screws so they bear evenly on leveling plates. Replace vee belts with matched set, or adjust roll. Balance chuck or reduce spindle speed.</p> <p>Contact local representative or motor manufacturer.</p>
Chatter	<p>Tool bit improperly ground or not on center</p> <p>Tool overhang too great</p> <p>Using improper surface feet</p> <p>Feed rate too high or too low</p> <p>Gibs of cross slide or pound rest loose</p> <p>Spindle bearings worn</p>	<p>Regrind tool bit or adjust tool holder so that area of contact between tool bit and work is decreased. Avoid extreme negative rake angle. Keep point of tool bit as close as possible to tool holder.</p> <p>Reduce or increase spindle speed.</p> <p>Reduce or increase feed.</p> <p>adjust gibs.</p> <p>Adjust spindle bearings.</p>
Chatter (cont'd)	<p>Work Improperly supported</p> <p>Vibration</p> <p>Spindle bearing loose</p>	<p>Adjust tailstock center. Use steady rest or follow rest on long slender shafts. Minimize tailstock barrel extension.</p> <p>See "Vibration" trouble above.</p> <p>Adjust spindle bearings.</p>
Work not turned straight	<p>Headstock and tailstock centers not aligned</p> <p>Work improperly supported</p> <p>Bed not level</p> <p>Tool not on center when using taper attachment</p>	<p>Align tailstock center.</p> <p>Use steady rest or follow rest.</p> <p>Reduce overhang from chuck. Relevel bed, using precision level.</p> <p>Put tool on center.</p>
Work out or round	<p>Work loose between centers or centers are excessively worn--work centers out of round</p> <p>Loose headstock spindle bearings</p>	<p>Adjust tailstock center. regrind centers. Lap work centers.</p> <p>Adjust headstock spindle bearings.</p>
Cross slide or compound rest movement does not coincide with dial movement of respective adjusting screw.	<p>Gib setting too tight or too loose</p> <p>Workpiece is too long and slender</p>	<p>Adjust gibs.</p> <p>Use steady rest or follow rest.</p>

Mechanical Drawings & Parts Breakdown List

Note: When ordering parts, please be prepared with,

1. Machine model & serial number.
2. Item number.
3. Part number and description.
4. Year of Production.
5. Voltage & horsepower.
6. Quantity

E
F

1
2
3
4

S

A

B

C

D

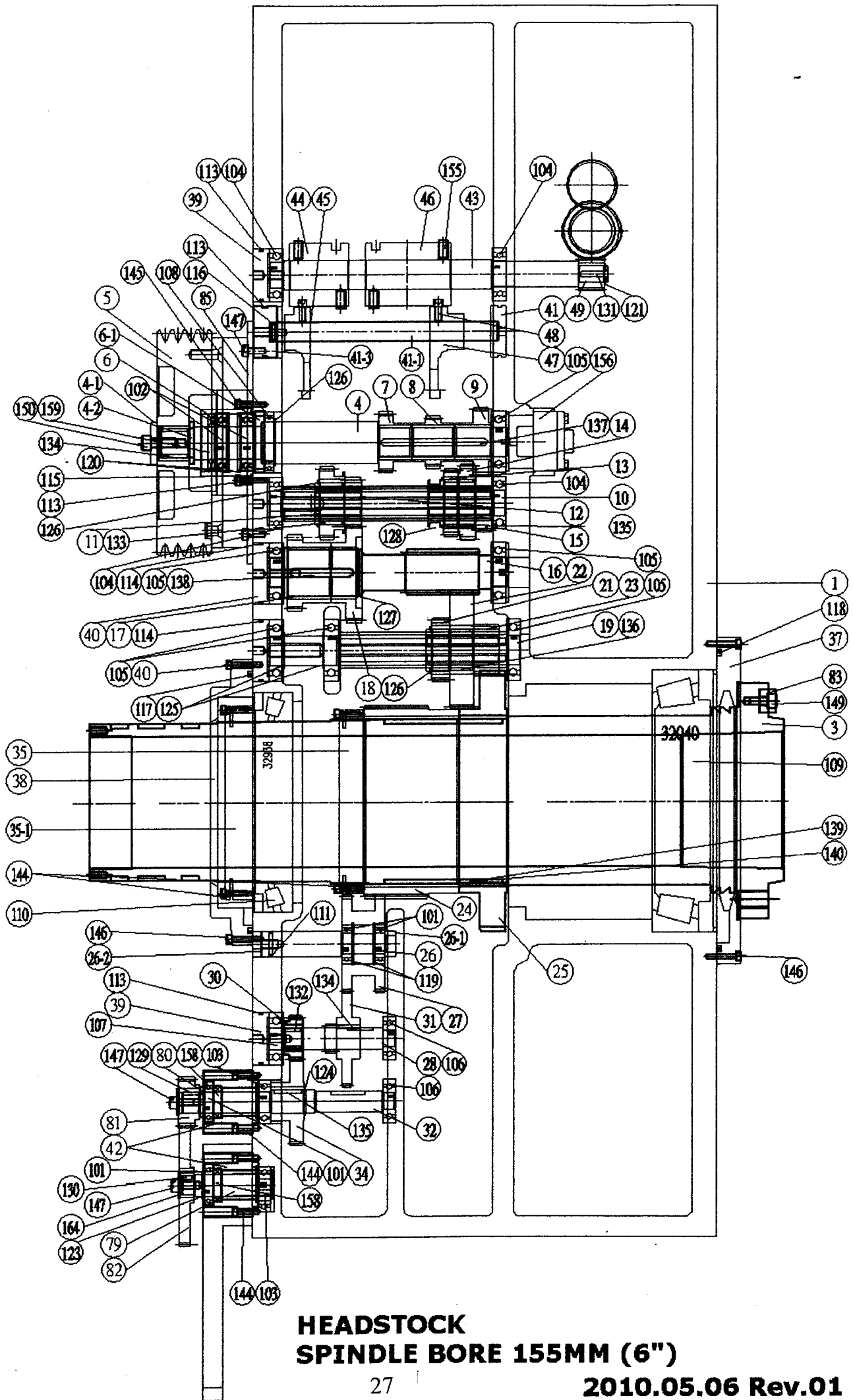

**HEADSTOCK
SPINDLE BORE 155MM (6")**

Headstock

2010.05.06 Rev.01

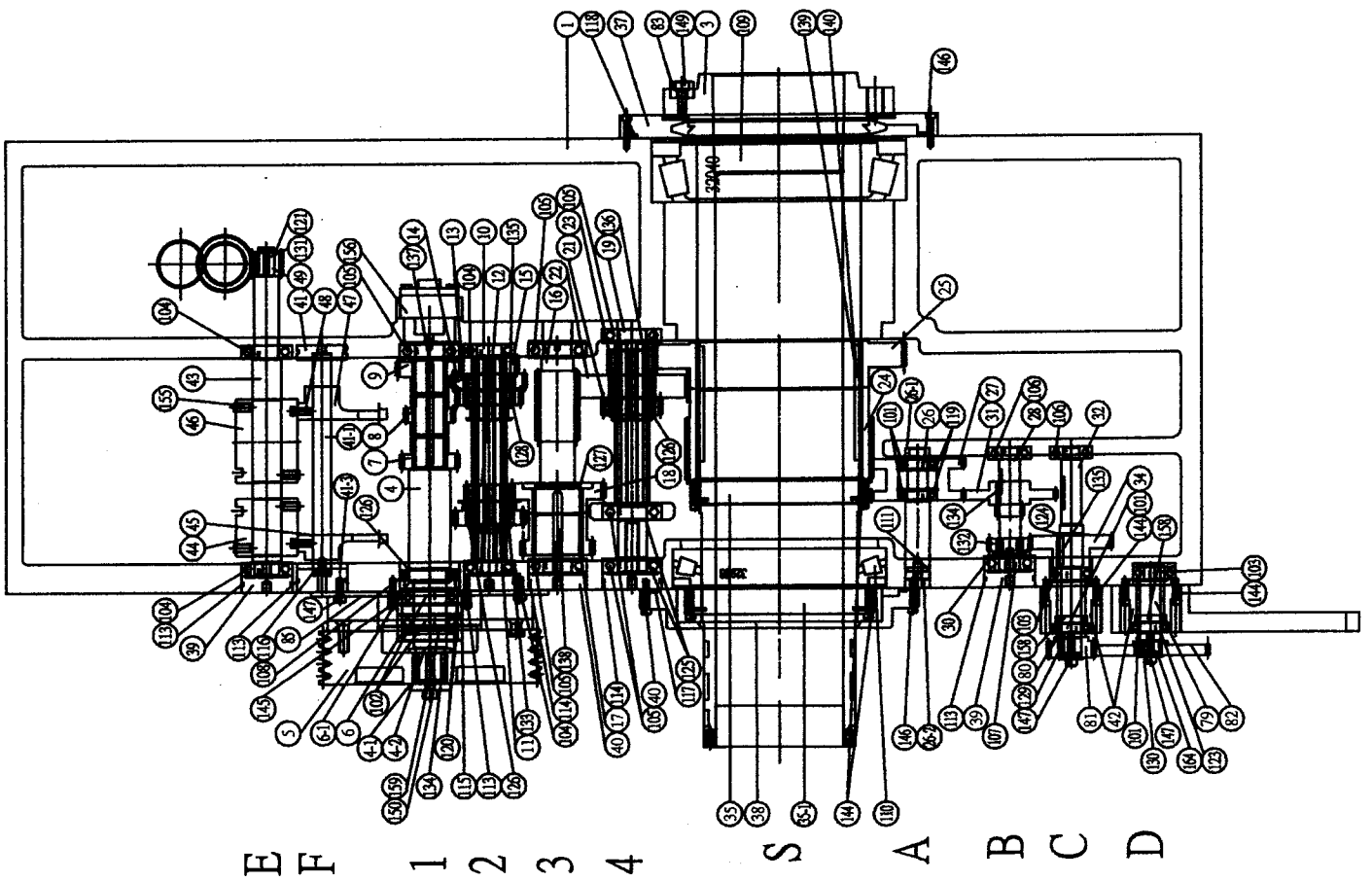
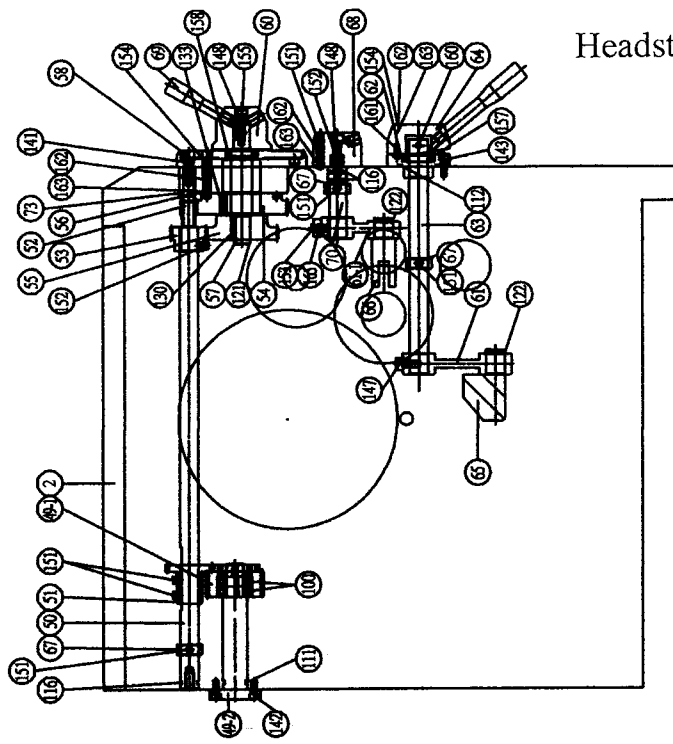

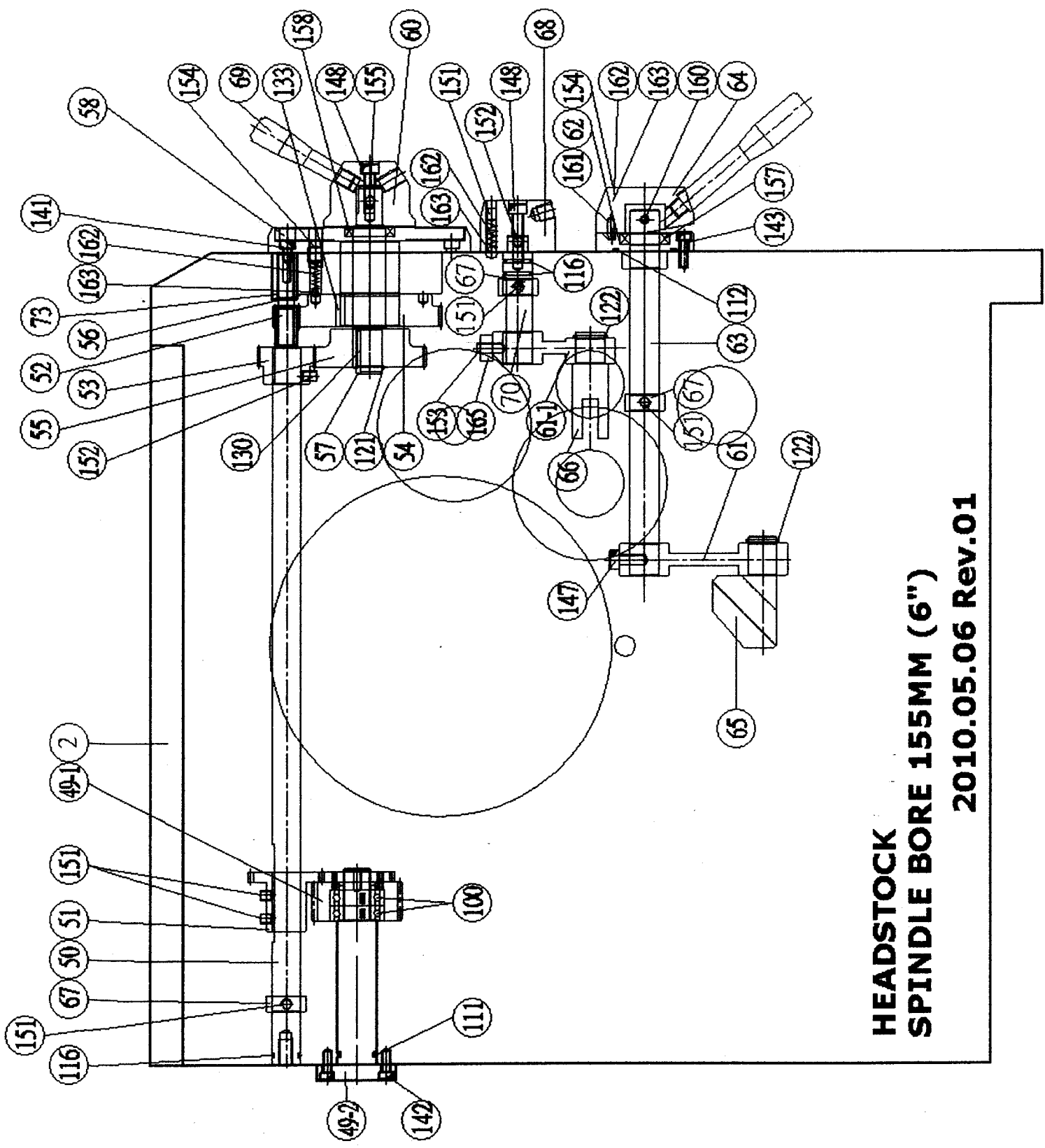

**HEADSTOCK
SPINDLE BORE 155MM (6")
2010.05.06 Rev.01**

LIST OF 33 HEADSTOCK SPINDLE BORE 155MM (6")
CONVENTIONAL TYPE

NO.	PARTS NO.	DESCRIPTION	Q'TY	REMARK
001	33HA-601000	HEADSTOCK HOUSING	1	
002	33HD-402000	COVER	1	
003	33HD-6030A0	SPINDLE	1	
004	18HA-004A00	SHAFT	1	
004-1	18HA-004100	SPACER	1	
004-2	33HA-A04200	SPACER	1	
005	18HA-0051A1	V-PULLEY	1	
006	33HA-406000	COVER	1	
006-1	33HA-406200	SPACER	1	
007	18HA-007000	GEAR	1	
008	18HA-008000	GEAR	1	
009	18HA-009000	GEAR	1	
010	18HA-010000	SHAFT	1	
011	18HA-011000	GEAR	1	
012	18HA-012000	GEAR	1	
013	18HA-013000	GEAR	1	
014	18HA-014000	GEAR	1	
015	18HA-015000	GEAR	1	
016	18HA-016000	SHAFT	1	
017	18HA-017000	GEAR	1	
018	18HA-018000	GEAR	1	
019	25HA-419000	SHAFT	1	
021	25HA-421000	GEAR	1	
022	25HA-422000	GEAR	1	
023	25HA-423000	GEAR	1	
024	25HA-624000	GEAR	1	
025	25HA-625000	GEAR	1	
026	18HA-026000	SHAFT	1	
026-1	18HA-026100	SLEEVE	1	
026-2	33HD-426200	SLEEVE	1	
027	25HA-427000	GEAR	1	
028	18HA-028000	SHAFT	1	
030	18HA-030000	GEAR	1	
031	25HA-631000	GEAR	1	
032	33HD-432000	SHAFT	1	
034	33HD-634000	GEAR	1	
035	25HA-635000	MASTER NUT	1	
035-1	25HA-635100	MASTER NUT	1	
037	25HA-637000	MASTER SNAP COVER-FRONT	1	
038	25HA-638000	MASTER SNAP COVER-REAR	1	
039	33HD-439000	COVER	3	
040	33HD-440000	COVER	2	
041	18HA-041000	SNAP COVER	1	
041-1	18HA-041100	SHAFT	1	
041-3	33HD-441300	SNAP COVER	1	

LIST OF 33 HEADSTOCK SPINDLE BORE 155MM (6")
CONVENTIONAL TYPE

NO.	PARTS NO.	DESCRIPTION	Q'TY	REMARK
042	33HD-442100	COVER	2	
043	33HD-443000	CAM SHAFT	1	
044	18HA-044000	CAM	1	
045	18HA-045000	SPEED CHANGE FORK	1	
046	18HA-046000	CAM	1	
047	18HA-047000	SPEED CHANGE FORK	1	
048	18HA-048000	COUNTERSINK SCREW	2	
049	18HA-049000	WORM SHATF	1	
049-1	25HA-449100	GEAR	1	
049-2	33HD-649200	SHAFT	1	
050	33HD-450000	SHAFT	1	
051	25HA-451000	GEAR	1	
052	18HA-052000	GEAR	1	
053	18HA-053000	GEAR	1	
054	18HA-054000	GEAR	1	
055	18HA-055000	GEAR	1	
056	18HA-056000	LOCKING POST	1	
057	18HA-057000	SHAFT	1	
058	18HA-058000	BRAND POST	1	
060	18HA-060000	LEVER BOSS	1	
061	25HA-461000	RICKER LEVER	1	
061-1	18HA-061100	RICKER LEVER	1	
062	25HA-462000	SPEED LEVER POST	1	
063	33HD-463000	ROCKER ARM	1	
064	18HA-064000	ROCKER LEVER POST	1	
065	25HA-465000	SPEED CHANGE FORK	1	
066	25HA-666000	SPEED CHANGE FORK	1	
067	18HA-067000	SPEED LEVER RING	3	
068	18HA-068000	LEVER BOSS	1	
069	18HA-069000	HANDLE	3	
070	33HD-670000	ROCKER ARM	1	
071	20A-011000	HANDLE	1	
073	18HA-073000	SLEEVE	1	
079	33HD-479100	SHAFT	1	
080	33B-038400	LOCKING PIN POST	1	
081	18HA-081000	GEAR	1	
082	33HD-482000	GEAR	1	
083	25HA-483000	FIX BLOCK	1	
085		BRAKER	1	
086	33HD-481000	SPACER	1	
100		Bearing 6004	2	
101		Bearing 6005	4	
102		Bearing 6008	2	
103		Bearing 6205	2	
104		Bearing 6206	4	

LIST OF 33 HEADSTOCK SPINDLE BORE 155MM (6")
CONVENTIONAL TYPE

NO.	PARTS NO.	DESCRIPTION	Q'TY	REMARK
105		Bearing 6207	6	
106		Bearing 6304	2	
107		Bearing 6305	1	
108		Bearing 6910	1	
109		Bearing 32040	1	
110		Bearing 32938	1	
111		O-Ring G25	2	
112		O-Ring G40	1	
113		O-Ring G55	4	
114		O-Ring G65	2	
115		O-Ring G75	1	
116		O-Ring P18	4	
117		O-Ring	1	
118		O-Ring	1	
119		C-Locker R47	2	
120		C-Locker R68	2	
121		C-Locker S20	2	
122		C-Locker S22	2	
123		C-Locker S25	1	
124		C-Locker S28	1	
125		C-Locker S35	2	
126		C-Locker S50	3	
127		C-Locker S55	1	
128		C-Locker S56	1	
129		Key 6*6*22	1	
130		Key 6*6*25	2	
131		Key 6*6*28	1	
132		Key 8*7*18	2	
133		Key 8*7*25	2	
134		Key 8*7*28	3	
135		Key 8*7*32	3	
136		Key 8*7*45	2	
137		Key 8*7*120	2	
138		Key 10*8*70	2	
139		Key 14*9*60	2	
140		Key 14*9*80	2	
141		Screw M6*10	3	
142		Screw M6*16	3	
143		Screw M6*20	2	
144		Screw M6*25	10	
145		Screw M6*30	4	
146		Screw M6*35	16	
147		Screw M8*20	7	
148		Screw M8*25	2	
149		Screw M10*20	1	

LIST OF 33 HEADSTOCK SPINDLE BORE 155MM (6")
 CONVENTIONAL TYPE

NO.	PARTS NO.	DESCRIPTION	Q'TY	REMARK
150		Screw M10*30	1	
151		Set-Screw M8*8	6	
152		Set-Screw M8*10	2	
153		Set-Screw M8*20	1	
154		Set-Screw M10*10	2	
155		Set-Screw M10*20	5	
156		Oil Pump	1	
157		Oil Seal 22*38*8	1	
158		Oil Seal 25*38*8	3	
159		Oil Seal 68*40*7	1	
160		BOLT	1	
161		STEEL BAT	1	
162		SPRING	3	
163		BALL	3	
164		SPACER	1	
165		SCREW NUT M8	1	

FEED GEAR BOX

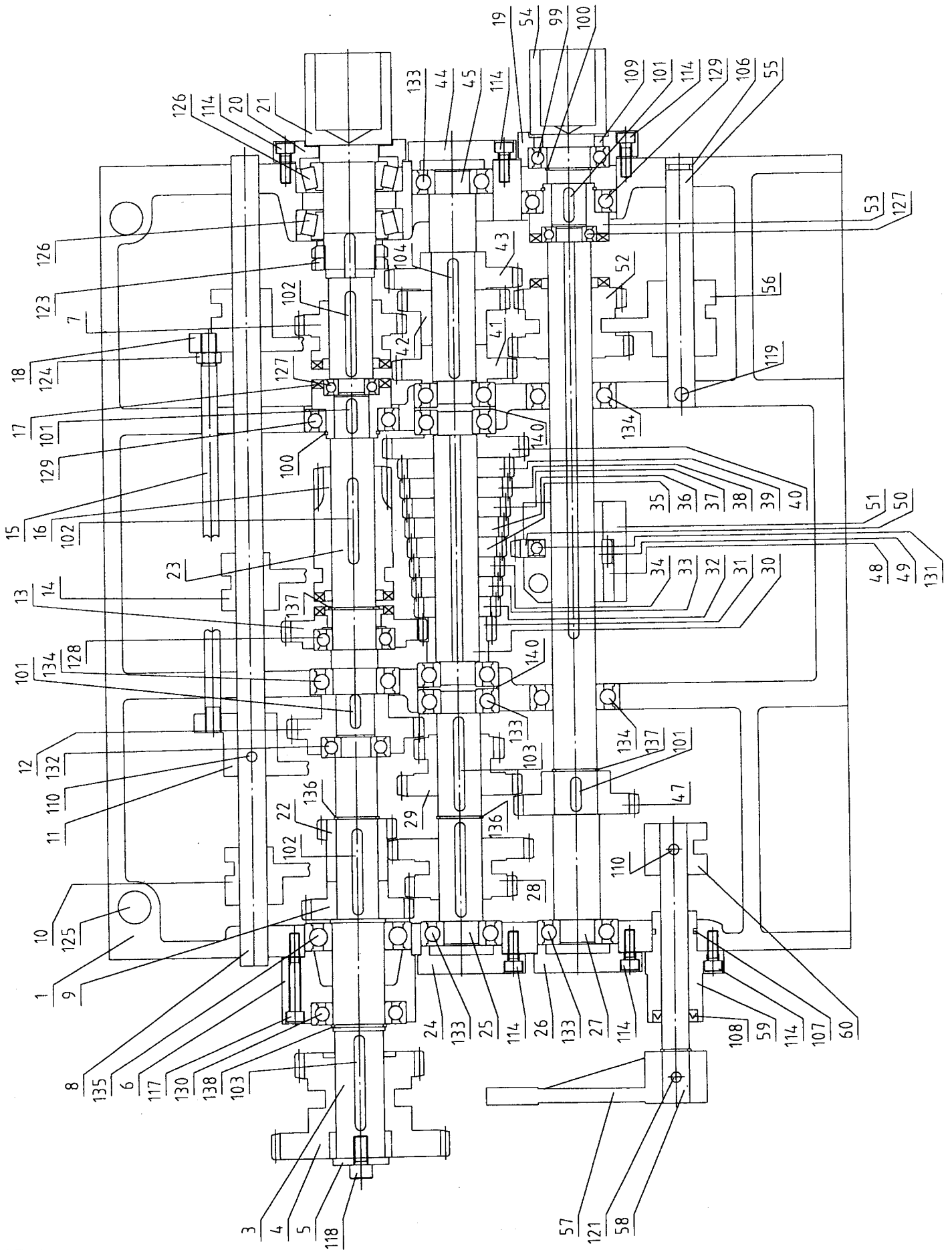

Feed Gear Box

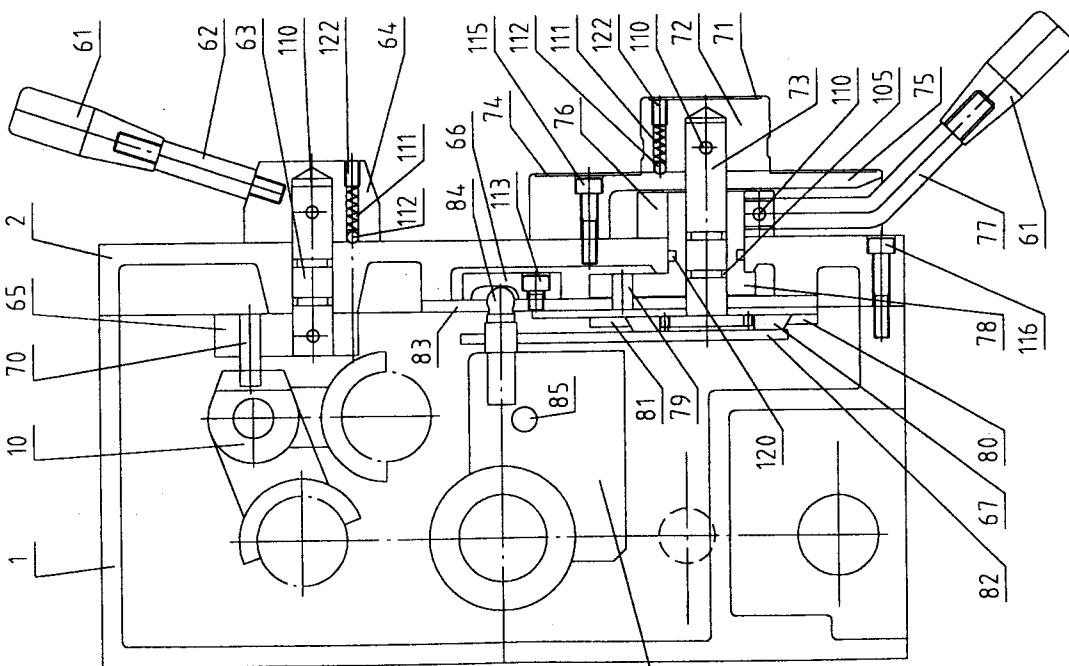
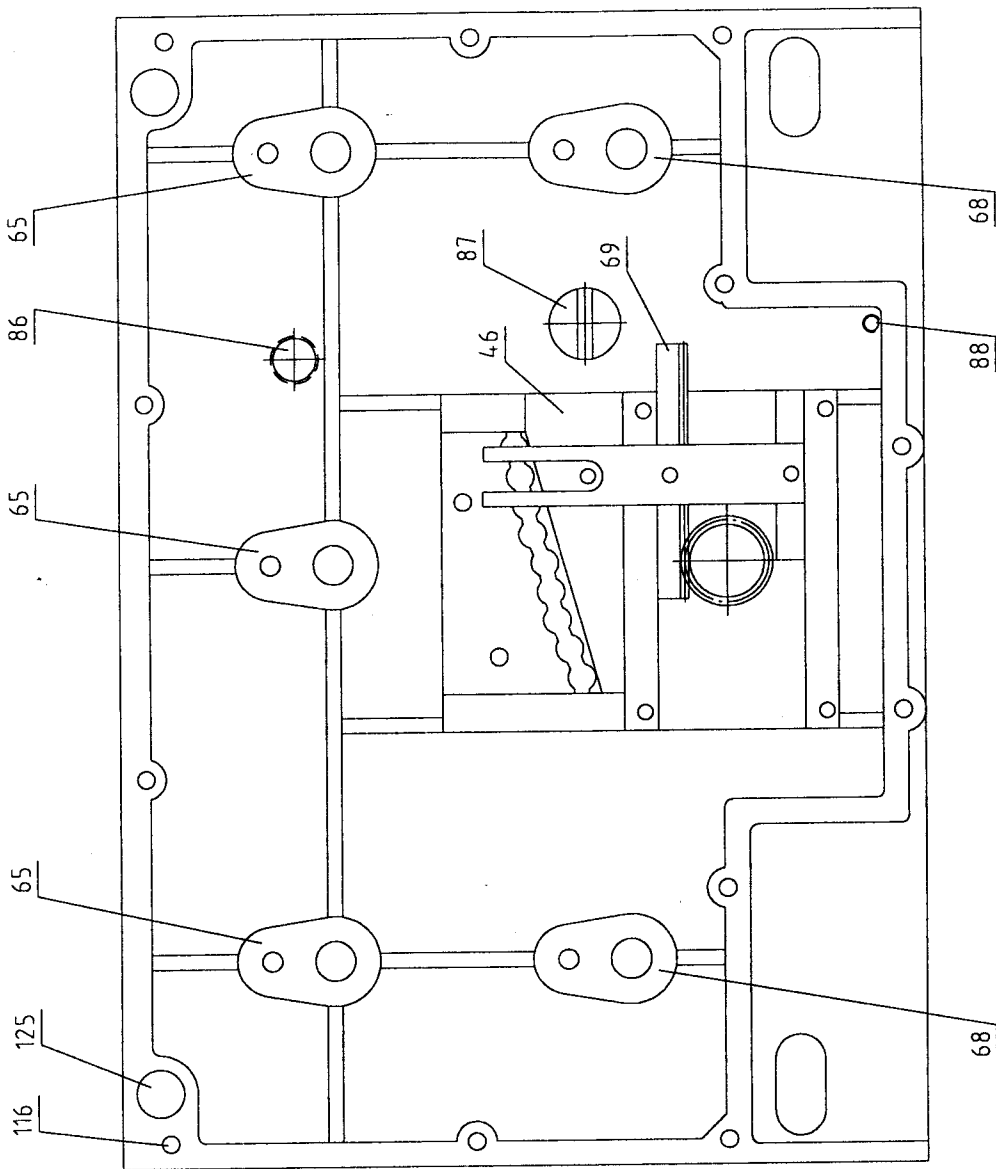

Gear Train

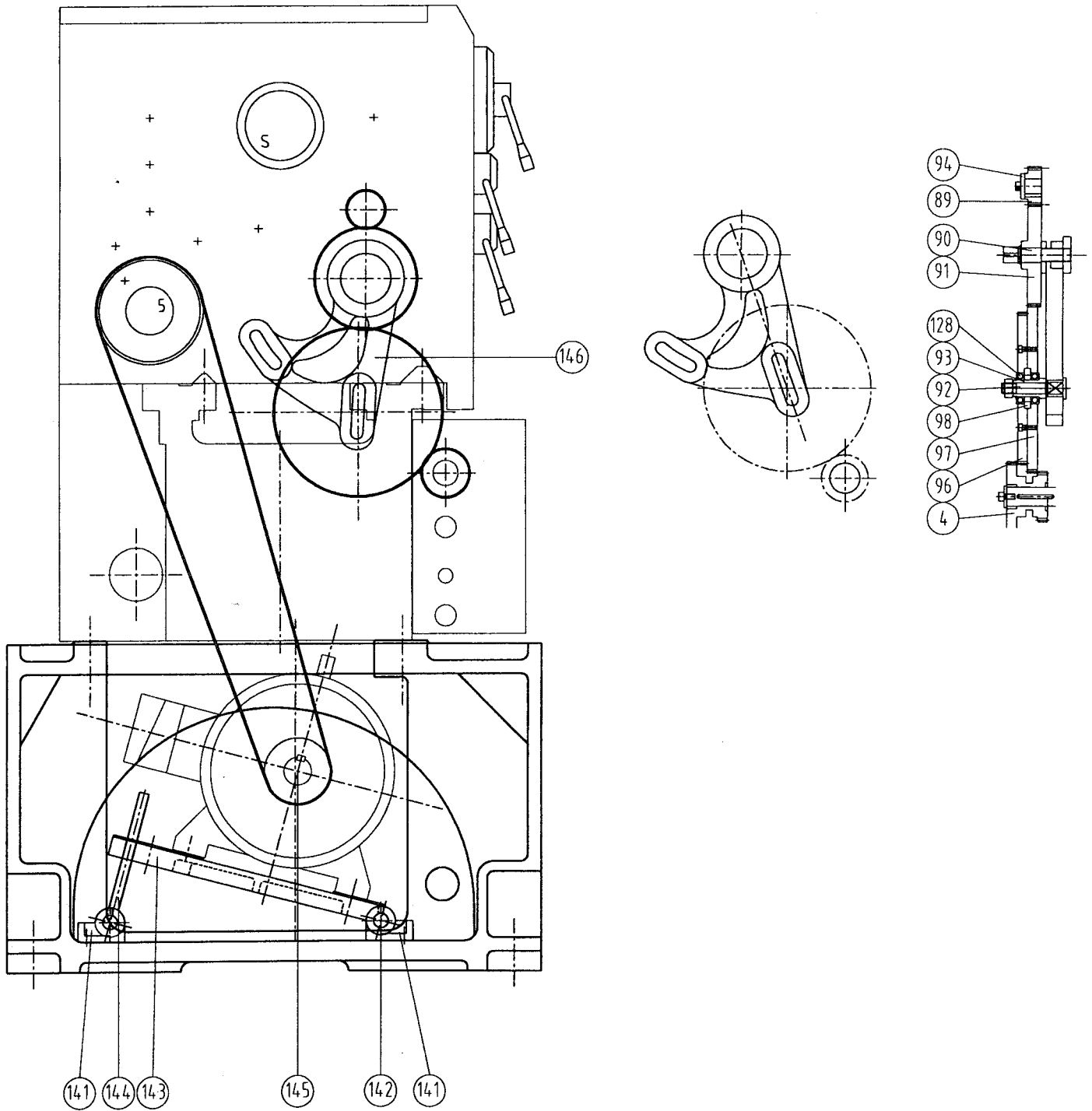

Gear Train

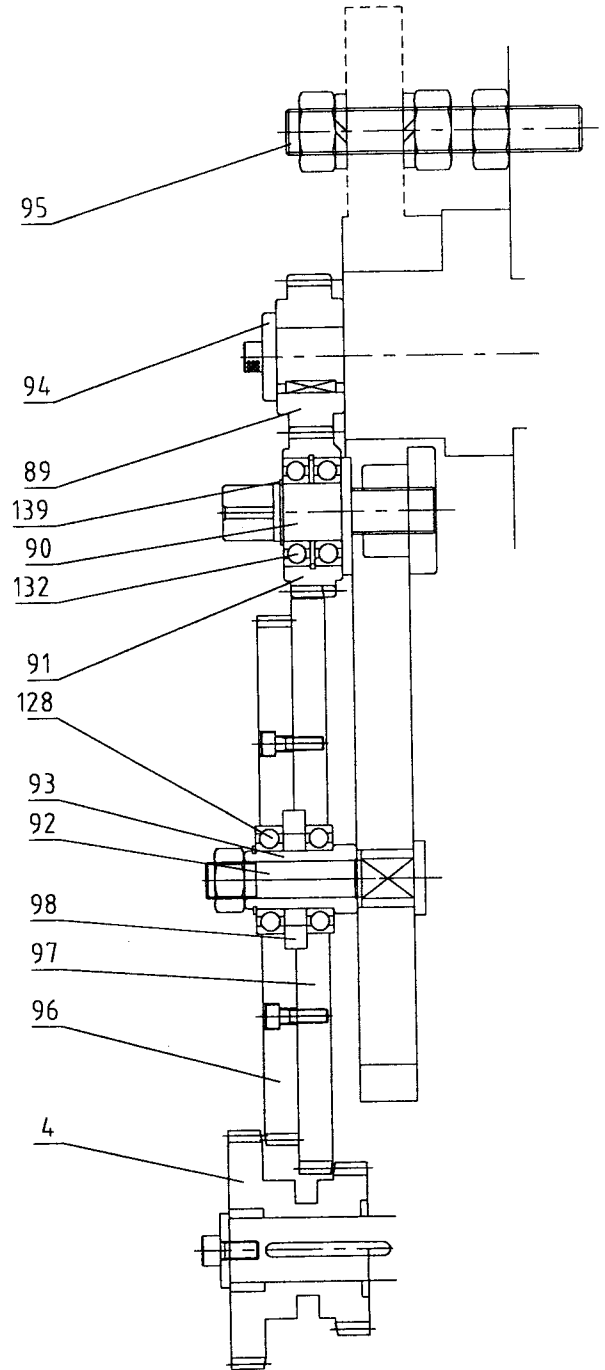
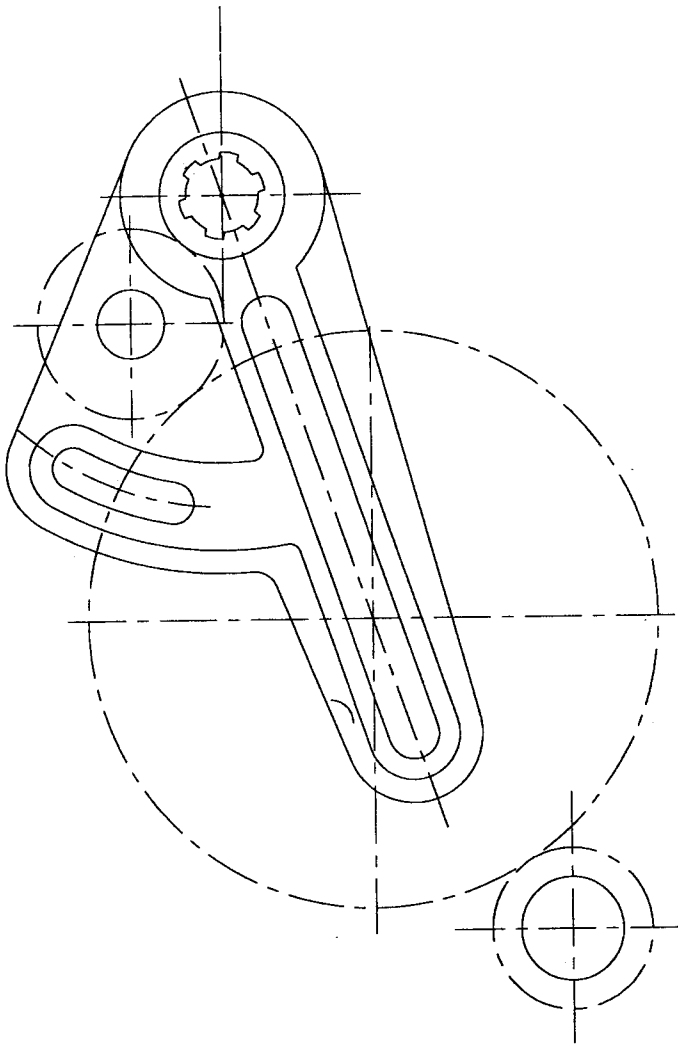

FEED GEAR BOX

SERIAL NO.	PARTS NO.	DESCRIPTION	Q'TY
1	X7001	Gear Box Casting	1
2	X7002	Cover	1
3	X7030	Shaft	1
4	X7007	Gear	1
5		Washer	1
6	X7040	Flange Bearing	1
7	X7015	Gear	1
8	X7029	Rod	1
9	X7008	Gear	1
10	X7045	Sliding Block	1
11	X7046	Sliding Block	1
12	X7010	Gear	1
13	X7011	Gear	1
14	X7047	Sliding Block	1
15	X7076	Shaft	1
16	X7012	Gear	1
17	X7014	Clutch	1
18	X7048	Sliding Block	1
19	X7043	Cover	1
20	X7041	Cover	1
21	X7032	Shaft	1
22	X7009	Gear	1
23	X7031	Shaft	1
24	X7042	Cover	1
25	X7033	Shaft	1
26	X7042	Cover	1
27	X7036	Shaft	1
28	X7016	Gear	1
29	X7017	Gear	1
30	X7034	Shaft	1
31	X7018	Gear	1
32	X7019- 1	Gear	1
33	X7019- 2	Gear	1
34	X7019- 3	Gear	1
35	X7019- 4	Gear	1
36	X7019- 5	Gear	1
37	X7019- 6	Gear	1
38	X7019- 7	Gear	1
39	X7019- 8	Gear	1
40	X7020	Gear	1

FEED GEAR BOX

SERIAL NO.	PARTS NO.	DESCRIPTION	Q'TY
41	X7021	Gear	1
42	X7022	Gear	1
43	X7023	Gear	1
44	X7042	Cover	1
45	X7035	Shaft	1
46	X7059	Guide Plate	1
47	X7024	Gear	1
48	X7054	Cllar	1
49	X7025	Gear	1
50	X7026	Gear	1
51	X7053	Swing Frame	1
52	X7027	Gear	1
53	X7014	Clutch	1
54	X7037	Shaft	1
55	X7039	Shaft	1
56	X7051	Sliding Block	1
57	X7049	Fork	1
58	X7038	Shaft	1
59	X7044	Flange Bearing	1
60	X7050	Sliding Block	1
61		Lever	1
62	X7077	Handle	1
63	X7067	Rod	1
64	X3024	Hub	1
65	X7065	Rocker Arm	3
66	X7058	Cover	1
67	X7060-1	Slide Wedge	1
68	X7066	Rocker Arm	2
69	X7060	Rack	1
70	X7064	Pin	1
71	X7072	Name Plate	1
72	X7073	Hub	1
73	X7061	Gear Shaft	1
74	X7071	Name Plate	1
75	X7068	Cover	1
76	X7056	Hub	1
77	X7056-1	Handle	1
78	X7055	Crank	1
79		Pin	1
80	X7063	Gib	1

FEED GEAR BOX

SERIAL NO.	PARTS NO.	DESCRIPTION	Q'TY
81	X7063	Gib	1
82	X7062	Sliding Plate	1
83	X7057	Locating Plate	1
84	X7052	Locating Pin	1
85		Shaft	1
86		Oil Plug	1
87		Oil Window	1
88		Oil Screw (PT 1/8")	1
89	X7003	Geat	1
90		Shaft	1
91	X7004	Geat	1
92		Shaft	1
93		Bushing	1
94		Washer	1
95		Screw	1
96	X7005	Gear	11
97	X7005-1	Gear	1
98	X7075	Space Collar	1
99		Bearing (6005Z)	1
100		Circlip (S-25)	1
101		Key (K06620)	4
102		Key(K06650)	3
103		Key(K06655)	2
104		Key (K06670)	1
105		O Ring (P11)	1
106		O Ring (P12)	1
107		O Ring (P21)	1
108		Oil Seal (TC16267)	1
109		Oil Seal (TC32458)	1
110		Pin (ϕ 5)	6
111		Spring (ϕ 6)	2
112		Sreel Ball (ϕ 1/4")	2
113		Screw (M6 \times 12L)	1
114		Screw (M6 \times 16L)	6
115		Screw (M6 \times 20L)	1
116		Screw (M6 \times 30L)	12
117		Screw (M6 \times 40L)	3
118		Screw (M6 \times 12L)	1
119		Set Screw (M6 \times 6L)	2
120		O Ring (P24)	1

FEED GEAR BOX

SERIAL NO.	PARTS NO.	DESCRIPTION	Q'TY
121		Set Screw (M8×12L)	1
122		Set Screw (M8×8L)	6
123		Bearing Nut (AN06)	2
124		Nut (3/8")	1
125		Screw (M12)	4
126		Bearing (30206)	2
127		Bearing (6002)	2
128		Bearing (6005Z)	3
129		Bearing (6006)	2
130		Bearing (6006Z)	1
131		Bearing (6200)	1
132		Bearing (6203)	3
133		Bearing (6204)	4
134		Bearing (6205)	3
135		Bearing (6206)	1
136		Circlip (S- 24)	1
137		Circlip (S- 25)	3
138		Circlip (S- 30)	2
139		Circlip (S- 17)	1
140		Circlip (R- 45)	2
141	33B- 015	Locking Post	2
142		Locking Pin	2
143	33B- 023	Base Plste	1
144	33B- 027	Gasket Bracket	4
145	20B- 042	Pulley	1
146	33B- 038	Gear Bracket	1

Apron

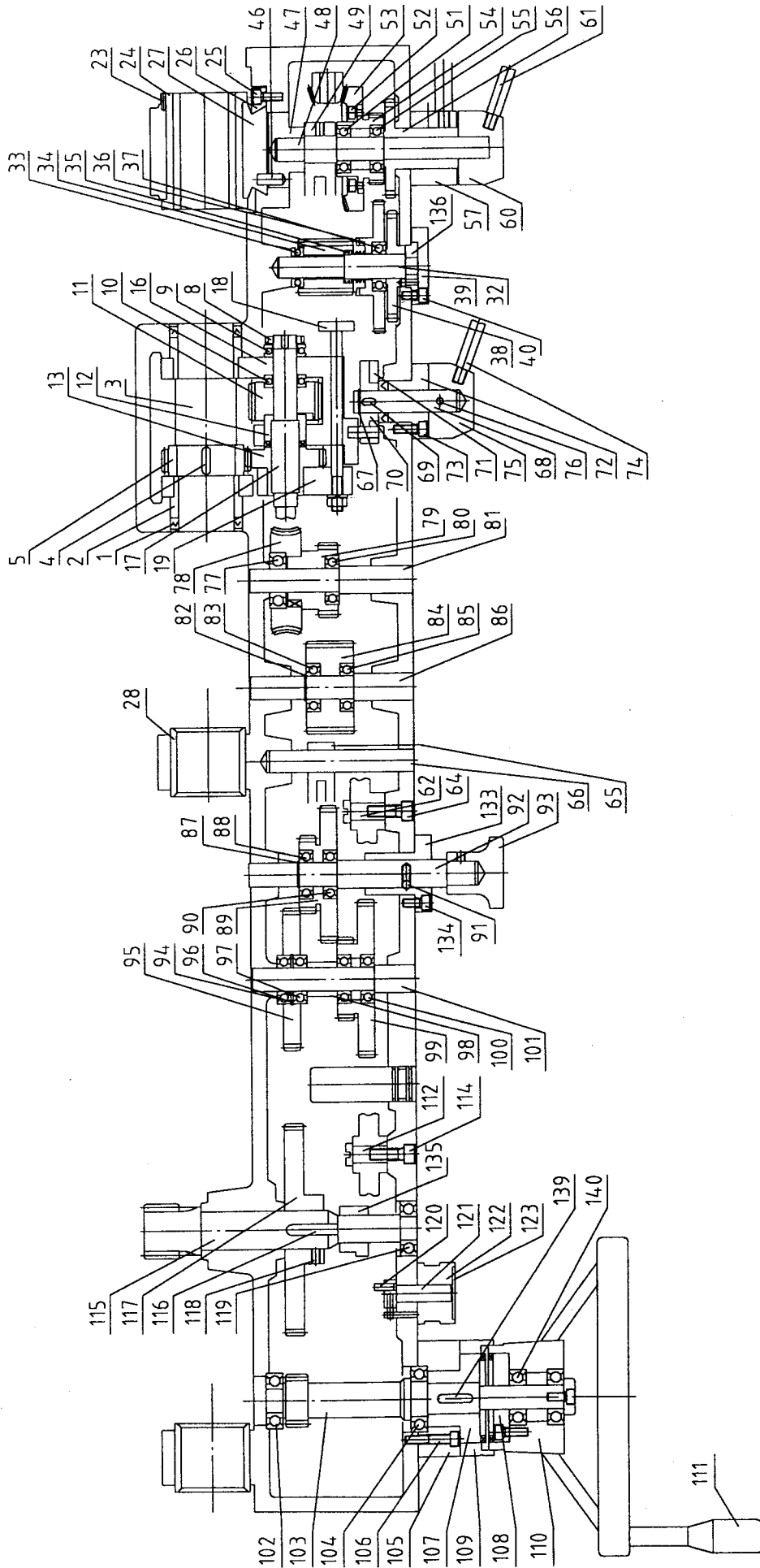

Apron

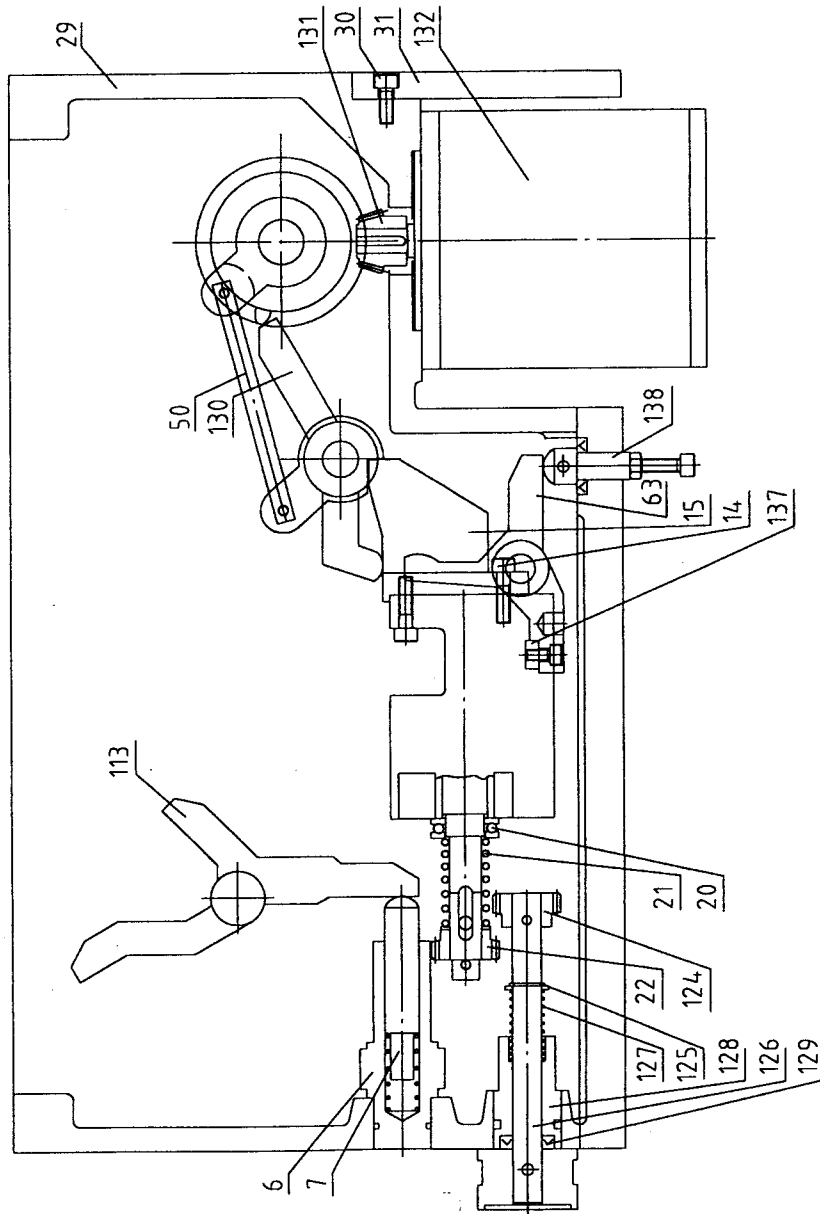
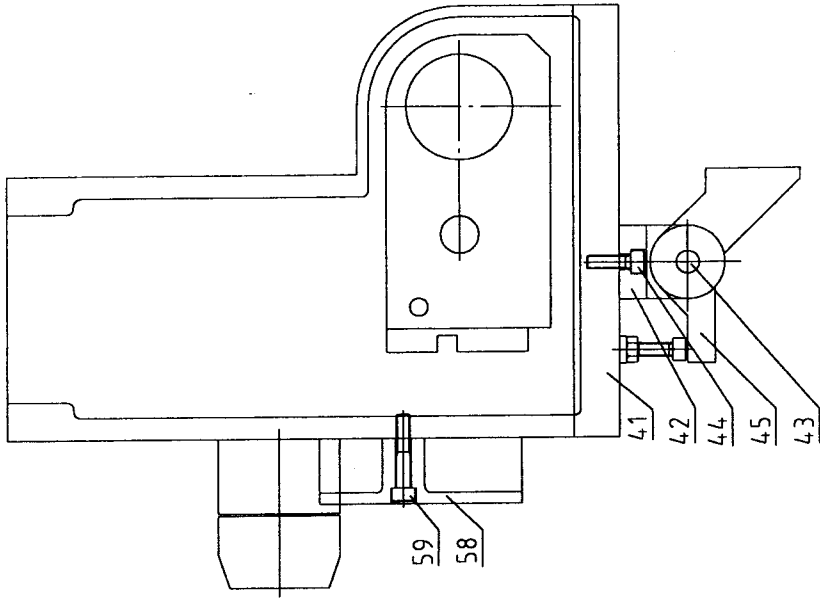

APRON

SERIAL NO.	PARTS NO.	DESCRIPTION	Q'TY
1		Oil Sealer (40528)	2
2	A3005	Bushing	2
3	A3004	Shaft	1
4		Key (6×6×20)	1
5	A3006	Gear	1
6	A3057	Oil Bearing	1
7	A3058	Shaft	1
8		Nut (AN03)	1
9		Bearing (51103)	1
10		Bearing (51103)	1
11	A3009	Worm	1
12	A3008	Bushing	1
13	A3007	Gear	1
14		Screw (M6×16L)	2
15	A3037	Rack	1
16	A3003	Bracket	1
17	A3032	Shaft	1
18	A3049	Shaft	1
19	A3048	Bracket	1
20		Bearing(51103)	1
21		Spring	1
22	A3025	Gear	1
23		Pin (φ3×8)	4
24	A3068	Sleeve	1
25		Screw (M8×20L)	2
26	A3060	Regulator	1
27	A3067	Bracket	1
28	A3066	Sleeve	2
29	A3001	Apron Box	1
30		Screw (M6×16L)	2
31	A3044	Cover	1
32	A3031	Shaft	1
33		Bearing (51103)	1
34	A3074	Gear	1
35		Spring	1
36	A3012	Gear	1
37		Bearing (6003)	1
38	A3076	Gear	1
39	A3079	Cover	1
40		Screw (M6×16L)	2

APRON

SERIAL NO.	PARTS NO.	DESCRIPTION	Q'TY
41	A3002	Cover	1
42	A3065	Bracket	1
43		Shaft	1
44		Screw (M6×16L)	2
45	A3045	Rack	1
46		Pin	2
47	A3020	Shaft	1
48	A3021	Shaft	1
49	A3042	Bracket	1
50	A3038	Shaft	1
51		Bearing (6003)	1
52		Screw (M5×8L)	3
53	A3024-2	Gear	1
54	A3024-1	Gear	1
55		Bearing (6003)	1
56	A3046	Gear	1
57	A3080	Cover	1
58	A3071	Cover	1
59		Screw (M6×35L)	2
60	X3024	Hub	1
61		Handle	1
62	A3053	Shaft	1
63	A3050	Bracket	1
64		Screw (M8×25L)	1
65	A3043	Bracket	1
66	A3077	Shaft	1
67		Snap Ring (S16)	1
68	A3041	Shaft	1
69		Key (5×5×10)	1
70	A3061	Lever	1
71	A3062	Lever	1
72	A3040	Cover	1
73		Screw (M6×16L)	3
74		Handle	1
75	X3024	Hub	1
76		Pin	1
77		Bearing (6203)	1
78	A3010	Gear	1
79	A3011	Gear	1
80		Bearing (6203)	1

APRON

SERIAL NO.	PARTS NO.	DESCRIPTION	Q'TY
81	A3035	Shaft	1
82		Snap Ring (S17)	1
83		Bearing (6003)	1
84	A3013	Gear	1
85		Bearing (6203)	1
86	A3034	Shaft	1
87		Snap Ring (S17)	1
88		Bearing (6003)	1
89	A3014	Gear	1
90		Bearing (6003)	1
91		Steel Ball	1
92	A3036	Shaft	1
93	A3047	Handle	1
94		Bearing (6003)	1
95	A3016	Gear	1
96		Snap Ring (R35)	1
97		Bearing (6003)	1
98	A3030	Washer	1
99	A3015	Gear	1
100		Bearing (6003)	2
101	A3033	Shaft	1
102		Bearing (6203)	1
103	A3019	Gear Shaft	1
104		Bearing (6005)	1
105	A3051	Cover	1
106		Screw (M6×16L)	3
107	A3028	Clutch	1
108	A3027	Clutch	1
109	A3052	Index Ring	1
110	A3069	Hand Wheel	1
111		Handle	1
112	A3053	Shaft	1
113	A3054	Bracket	1
114		Screw (M8×25L)	1
115	A3018	Gear Shaft	1
116		Key (8×7×30L)	1
117	A3017	Gear	1
118		Screw (M6×12L)	1
119		Bearing (6203)	1
120		Pin	1

APRON

SERIAL NO.	PARTS NO.	DESCRIPTION	Q'TY
121	A3056	Shaft	1
122	A3072	Handle	1
123	A3039	Cover	1
124	A3025	Gear	1
125		Snap Ring (S12)	1
126	A3026	Shaft	1
127		Spring	1
128	A3029	Shaft	1
129		oil Seal (13246)	1
130	A3022	Bracket	1
131	A3023	Gear	1
132		Motor	1
133	A3075	Cover	1
134		Screw (M6 ×12L)	2
135	A3055	Cam	1
136	A3078	Shaft	1
137	A3063	Block	1
138	A3059	Shaft	1
139		Key (6 ×6 ×25)	1
140		Bearing (6203)	2

Saddle, Tool Post & Compound Rest

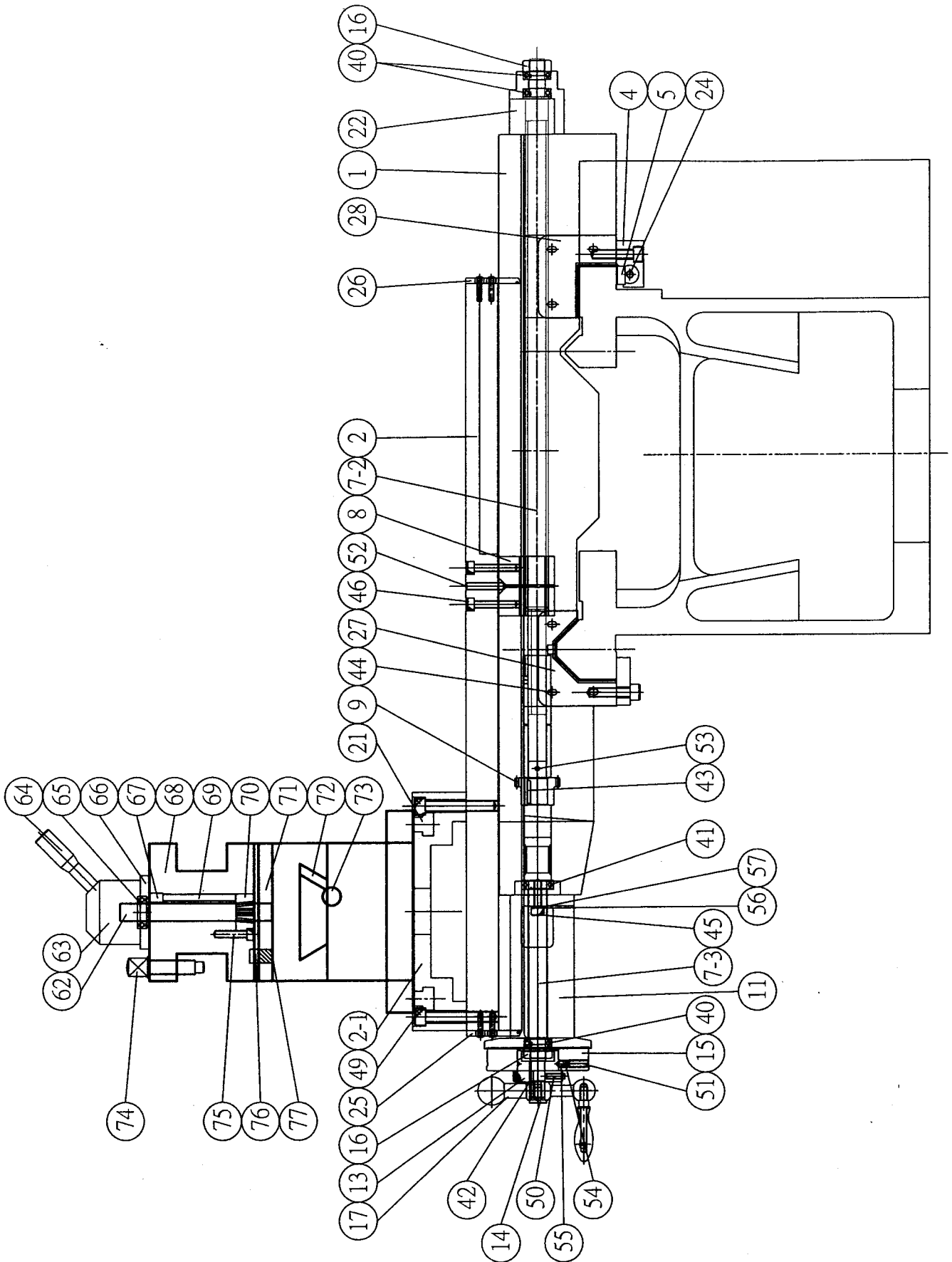

Saddle, Tool Post & Compound Rest

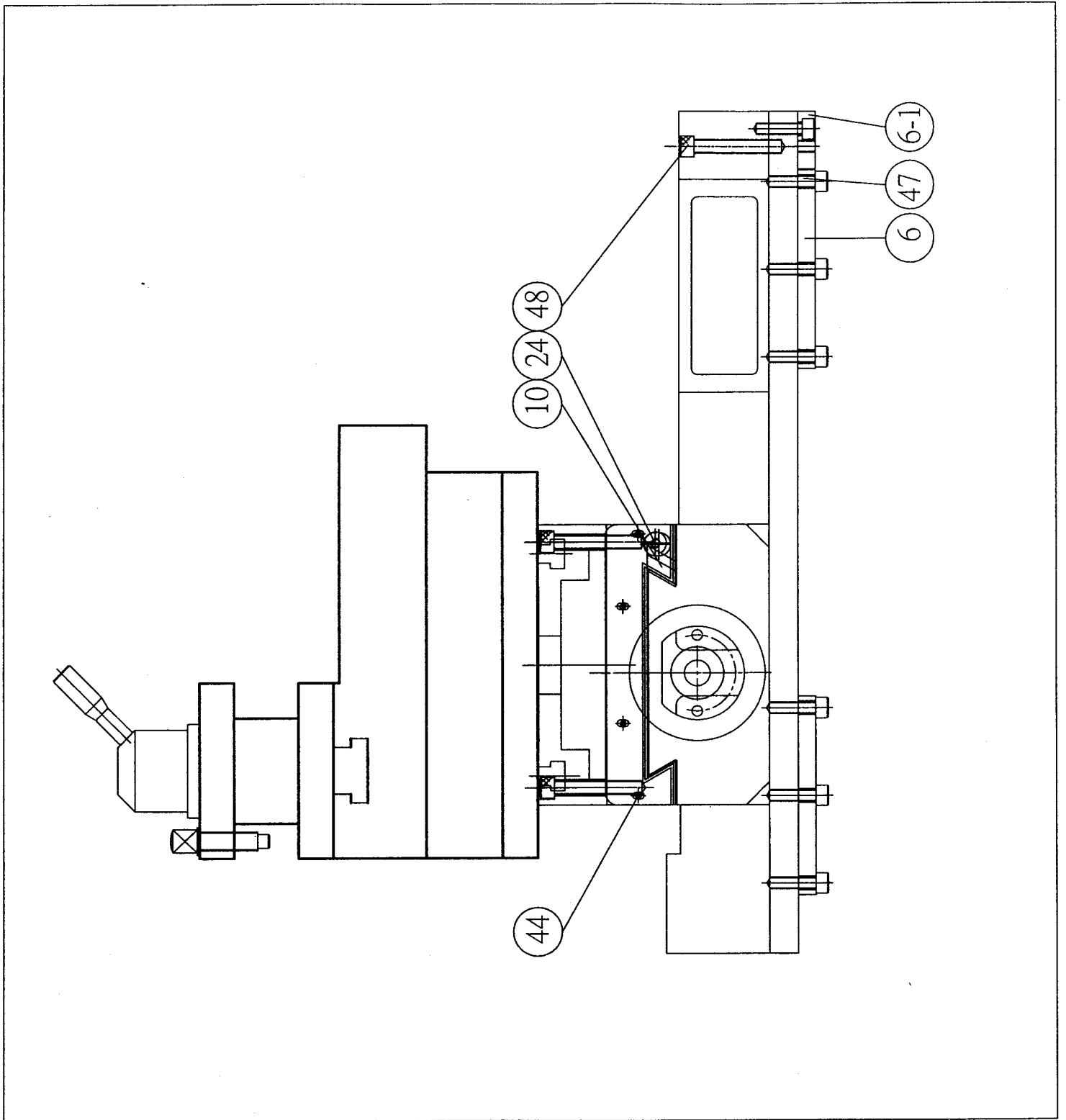

Saddle, Tool Post & Compound Assembly

Serial No.	Part No.	Description	Q'ty
1	33S-001000	Saddle	1
2	33S-002000	Cross-slide	1
2-1	33S-002100	Base for compound rest w/engraving degree	1
4	33CS-004200	Gib plate-back	1
5	33CS-005000	Gib	1
6	33S-006000	Saddle locating plate	2
6-1	33S-006100	Saddle plate	1
7-2	33S-007200	Lead screw	1
7-3	33S-007300	Front screw shaft	1
8	33S-008000	Screw nut assembly	1
9	33S-009000	Lead screw gear	1
10	33CS-003000	Gib-slide/saddle	1
11	33S-011000	Calibrating dial post	1
13	25S-013100	Dial insert	1
14	25S-014000	Locking screw	1
15	33S-015000	Calibrating dial	1
16	25S-016100	Hex screw nut	2
17	25S-017018B	Hand grip assembly	1
21	33S-021000	Square Nut	3
22	33S-022000	Leadscrew end bracket	1
24	25S-024100	Gib screw	4
25	33CS-020000	Wiper-front	1
26	33CS-023000	Wiper-back	1
27	33CS-022000	Wiper saddle/bed-front	2
28	33CS-021000	Wiper saddle/bed-rear	2
40	51103	Thrust bearing 51103	3
41	51104	Thrust bearing 51104	1
42	4*4*32	Key 4*4*32	1
43	6*6*25	Key 6*6*26	1
44	M5*12	Round head cap screw M5*12	20
45	M8*25	Socket head cap screw M8*25	2
46	M8*45	Socket head cap screw M8*45	4
47	M10*40	Socket head cap screw M10*40	12
48	M12*75	Socket head cap screw M12*75	1

Serial No.	Part No.	Description	Q'ty
49	M12	Socket head cap screw M12	4
50	M6*20	Socket set screw M6*20	1
51	M8*8	Socket set screw M8*8	1
52	M8*40	Socket set screw M8*40	2
53		Roll pin	1
54		Spring	1
55		Steel ball M8	1
56		Washer M8	2
57		Spring washer M8	2
62		Clamping bolt	1
63		Handle boss	1
64	33S-054	Handle	1
65	33S-055	Thrust bearing 51104	1
66	33S-056	Bearing spacer	1
67	33S-057	Set screw	3
68	33S-058	Tool post	1
69	33S-059	Setting pin	1
70	33S-060	Sleeve	1
71	33S-061	Locking block	1
72	33S-062	Gib tool post	1
73	33S-063	Gib screw- tool post	1
74	33S-064	Seating screw	12
75	33S-065	Screw	3
76	33S-066	Pin	1
77	33S-067	Spring 5*12	1

TAILSTOCK

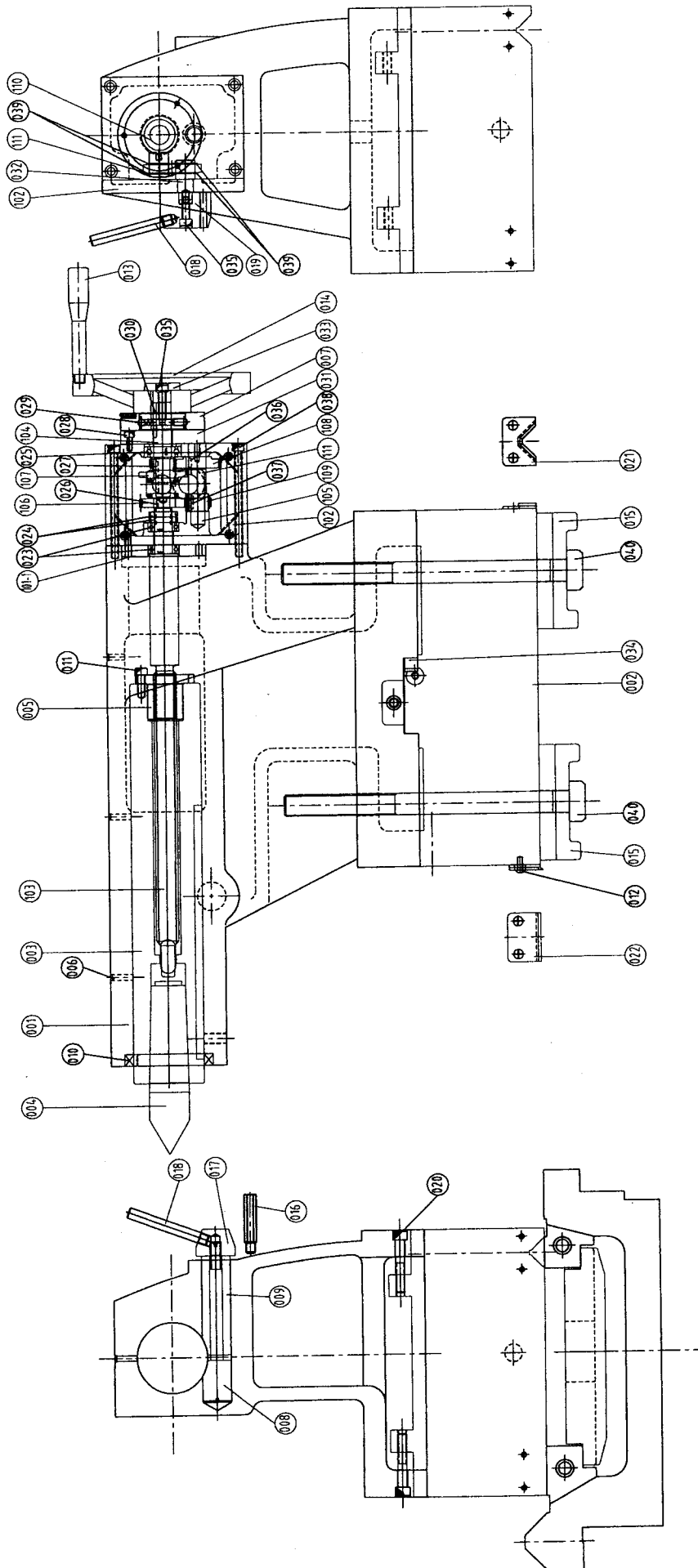

TAILSTOCK

SERIAL NO.	PARTS NO.	DESCRIPTION	Q'TY
1	33T-001	Tailstock	1
2	33T-002	Tailstock Base	1
3	33T-003	Quill	1
4	33T-004	Center	1
5	33T-005	Locking Nut	1
6	33T-006	Grease Cup	3
7	33T-007	Calibrating Ring	1
8	33T-008	Locking Sleeve	1
9	33T-009	Locking Sleeve	1
10	33T-010	Oil Sealer (100×80×13)	1
11	33T-011	Screw (M8×25L)	1
12	33T-012	Cap Screw (M6×15L)	8
13	33T-013	Handle	1
14	33T-014	Handwheel	1
15	33T-015	Holding Down Plate	2
16	33T-016	Hex. Bolt	1
17	33T-017	Locking Stick	1
18	33T-018	Locking Lever	2
19	33T-019	Speed Lever Post	1
20	33T-020	Screw (M10×60L)	2
21	33T-021	Wiper Sheet	2
22	33T-022	Wiper Sheet	2
23	33T-023	Bearing (51104)	2
24	33T-024	Locking Nut (M20×1")	2
25	33T-025	Bearing (6004)	1
26	33T-026	Round Key (5×5×10)	1
27	33T-027	Round Key (5×5×35)	3
28	33T-028	Screw (M6×15L)	1
29	33T-029	Steel Ball (φ8)	1
30	33T-030	Round Key (6×6×32)	2
31	33T-031	Snap Cover	1
32	33T-032	Shaft	1
33	33T-033	Dog Plate	1
34	33T-034	Wedge	1
35	33T-035	Screw (M8×30L)	2
36	33T-036	Round Key (6×6×10)	1
37	33T-037	Round Key (5×5×15)	1
38	33T-038	Screw (M8×120L)	1
39	33T-039	C Locker (S22)	1
38	33T-038	Screw (M24×300L)	1

TAILSTOCK

SERIAL NO.	PARTS NO.	DESCRIPTION	Q'TY
101	33T-101	Speed Gear Box	1
101-1	33T-101-1	Locking Block	1
102	33T-102	Cover	1
103	33T-103	Screw Lever	1
104	33T-104	Mandrel	1
105	33T-105	Shaft	1
106	33T-106	Clutch Couple	1
107	33T-107	Clutch Couple	1
108	33T-108	Spur Gear	1
109	33T-109	Spur Gear	1
110	33T-110	Swing Block	1
111	33T-111	Bracket	1

Tailstock with Rotating Spindle

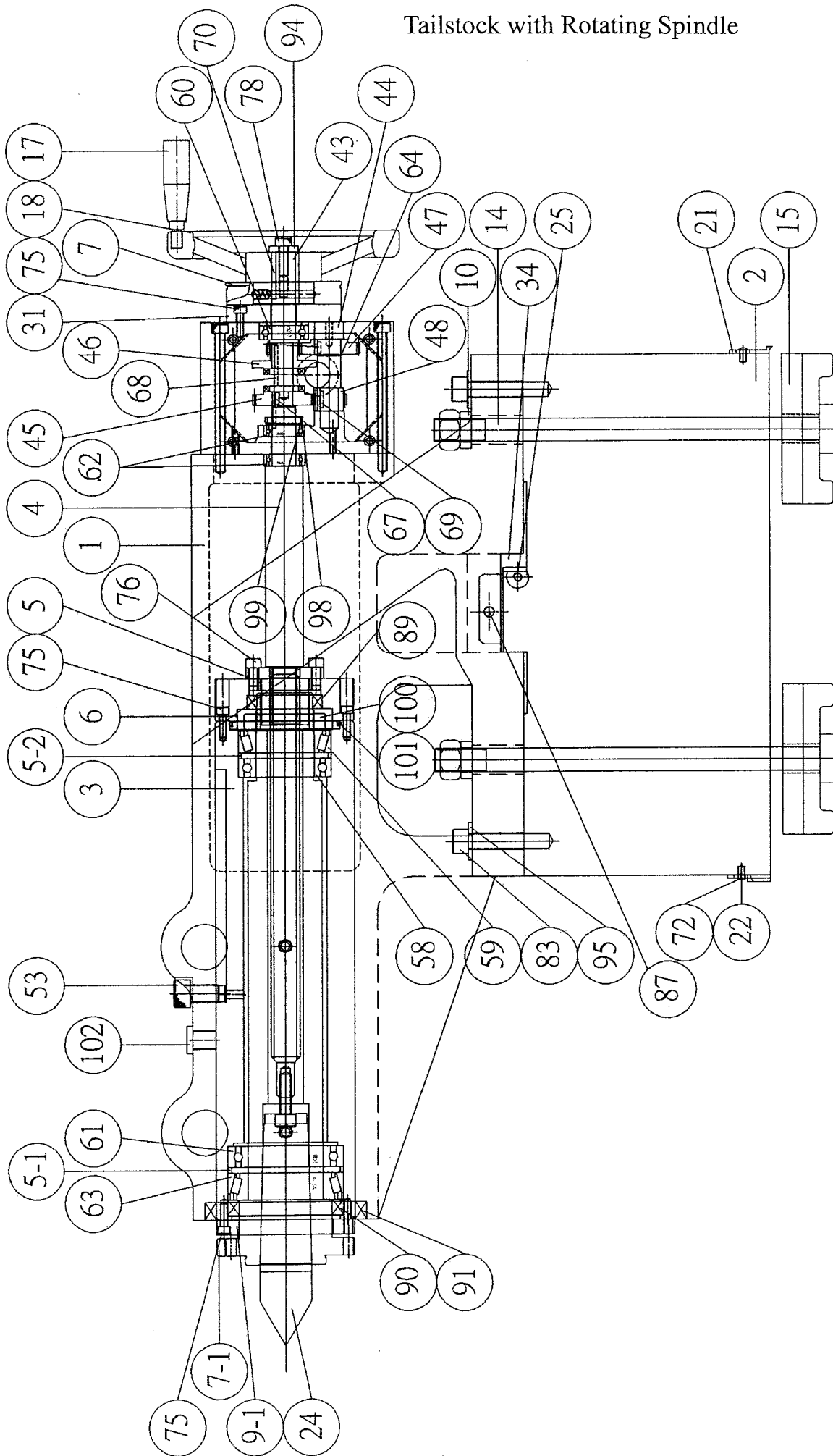

Tailstock with Rotating Spindle

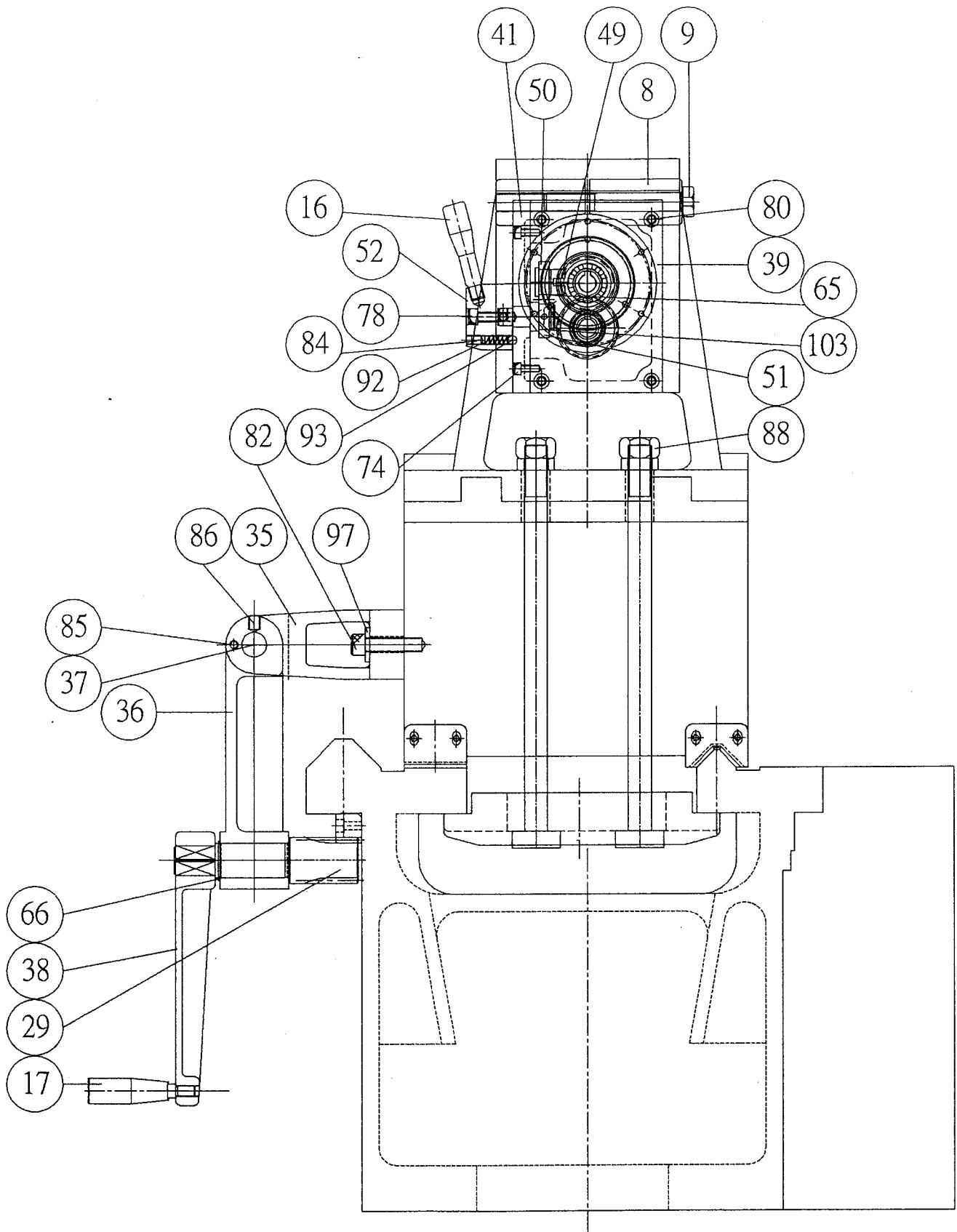

Tailstock with Rotating Spindle

Serial No.	Part No.	Description	Q'ty
1	33T-001000	Tailstock	1
2	26T-002C00	Tailstock base	1
	30T-002C00	Tailstock base	
	33T-002C00	Tailstock base	
3	33T-H03001	Quill	1
4	33T-1030I0	Tailstock leadscrew inch	1
	33T-1020M0	Tailstock leadscrew M	
5	25T-0050I0	Leadscrew nut inch	1
	25T-0050M0	Leadscrew nut M	
5-1	33T-H05001	Front bearing spacer	1
5-2	33T-H05002	Back bearing spacer	1
6	33T-H06001	Leadscrew base	1
7	25T-0070I0	Dial inch	1
	25T-0070M0	Dial M	
7-1	33T-H07001	Tailstock spindle	1
8	33T-H08000	Tailstock spindle locknut	2
9	33T-009000	Locknut screw	1
9-1	33T-H09001	Front cover	1
10	25T-010000	Spacer	4
14	26T-014000	Hex head cap screw	4
	30T-014000	Hex head cap screw	
	33T-014000	Hex head cap screw	
15	33T-015000	Locating plate	2
16	18HA-069000	Locking lever	1
17	20A-057000	Grip handle	2
18	20A-010000	Handwheel	1
21	33T-021000	Wiper blade-back	2
22	33T-022000	Wiper blade-front	2
24		Dead center	1
25	25S-024100	Gib screw	2
29	33T-029000	Gear shaft	1
31	33T-031000	Bearing cap	1
34	33T-034000	Gib	1
35	33T-035000	Top bracket	1

Serial No.	Part No.	Description	Q'ty
36	33T-036000	Lower bracket	1
37	33T-037000	Round shaft	1
38	33T-038000	Swing arm	1
39	33T-101000	Tailstock gear box	1
41	33T-102000	Gear box cover	1
43	33T-104000	Spacer shaft	1
44	33T-105000	Gear shaft	1
45	33T-106000	Clutch gear	1
46	33T-107000	Clutch gear	1
47	33T-108000	Gear	1
48	33T-109000	Engaging gear	1
49	33T-110000	Guiding bracket	1
50	33T-111000	Guiding bracket	1
51	33T-112000	Lower shaft	1
52	18HA-068000	Clutch engaging base	1
53	33T-039000	Locating screw	1
54	33T-039000	Locating screw	1
58		Ball bearing 6010	1
59		Taper roller bearing ET-32010X	1
60		Ball bearing 6004	1
61		Ball bearing 6013	1
62		Thrust bearing 51104	3
63		Taper roller bearing 32013XU	1
64		C type snap ring-S20	1
65		C type snap ring-S20	1
66		C type snap ring-S30	1
103		C type snap ring-S22	1
67		Key-5*5*10	2
68		Key-5*5*15	1
69		Key-5*5*32	1
70		Key-6*6*40	1
71		Key-8*7*15	2
72		Round head socket cap screw M6*10	8
74		Socket head cap screw-M6*16	4
75		Socket head cap screw-M6*20	15
76		Socket head cap screw-M8*16	3

Serial No.	Part No.	Description	Q'ty
78		Socket head cap screw-M8*25	2
80		Socket head cap screw-M8*120	4
82		Socket head cap screw-M12*50	2
83		Socket head cap screw-M14*70	4
84		Socket head set screw-M8*8	1
85		Socket head set screw-M8*25	1
86		Socket head set screw-M10*12	1
87		Socket head set screw-M10*45	1
88		Hex nut M20	4
89		Oil seal 48*65*10	1
90		Oil seal 80*100*13	1
91		Oil seal 120*140*15	1
92		Spring	2
93		Steel ball	2
94		Washer M8	1
95		Washer M14	4
97		Spring washer M12	2
98		Lock nut	1
99		Lock washer	1
100		Precision lock nut YSR-M50*P1.5	1
101		O ring G90	1
102		Oil fitting 3/8"	1

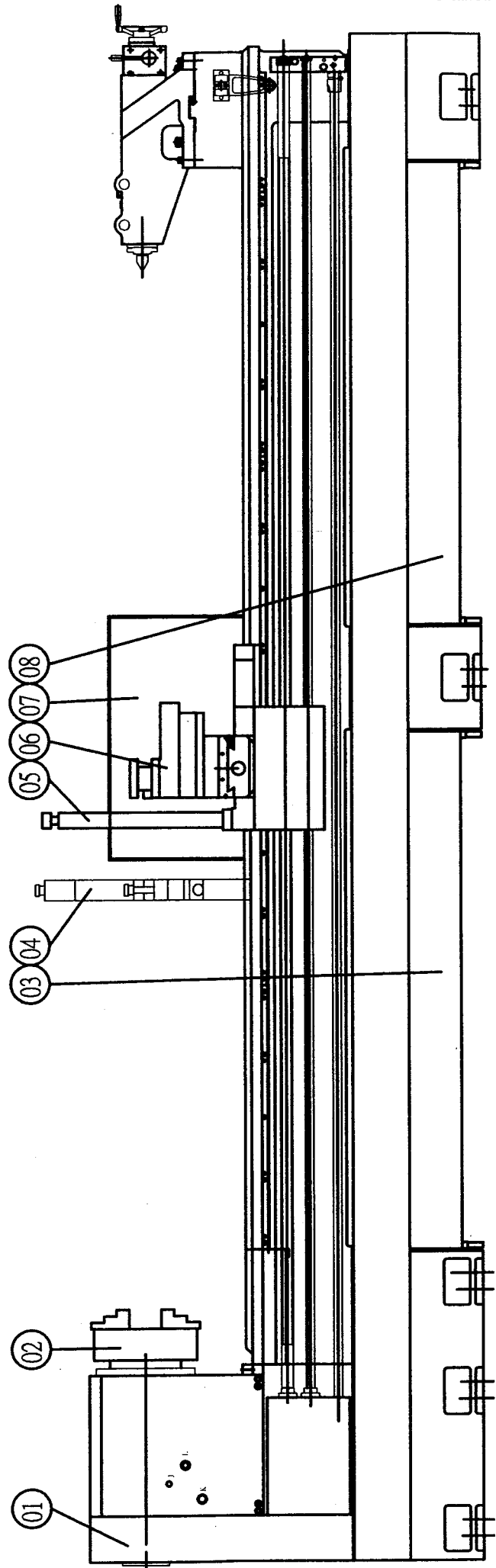

Bed Sheet Metal & Other Accessories

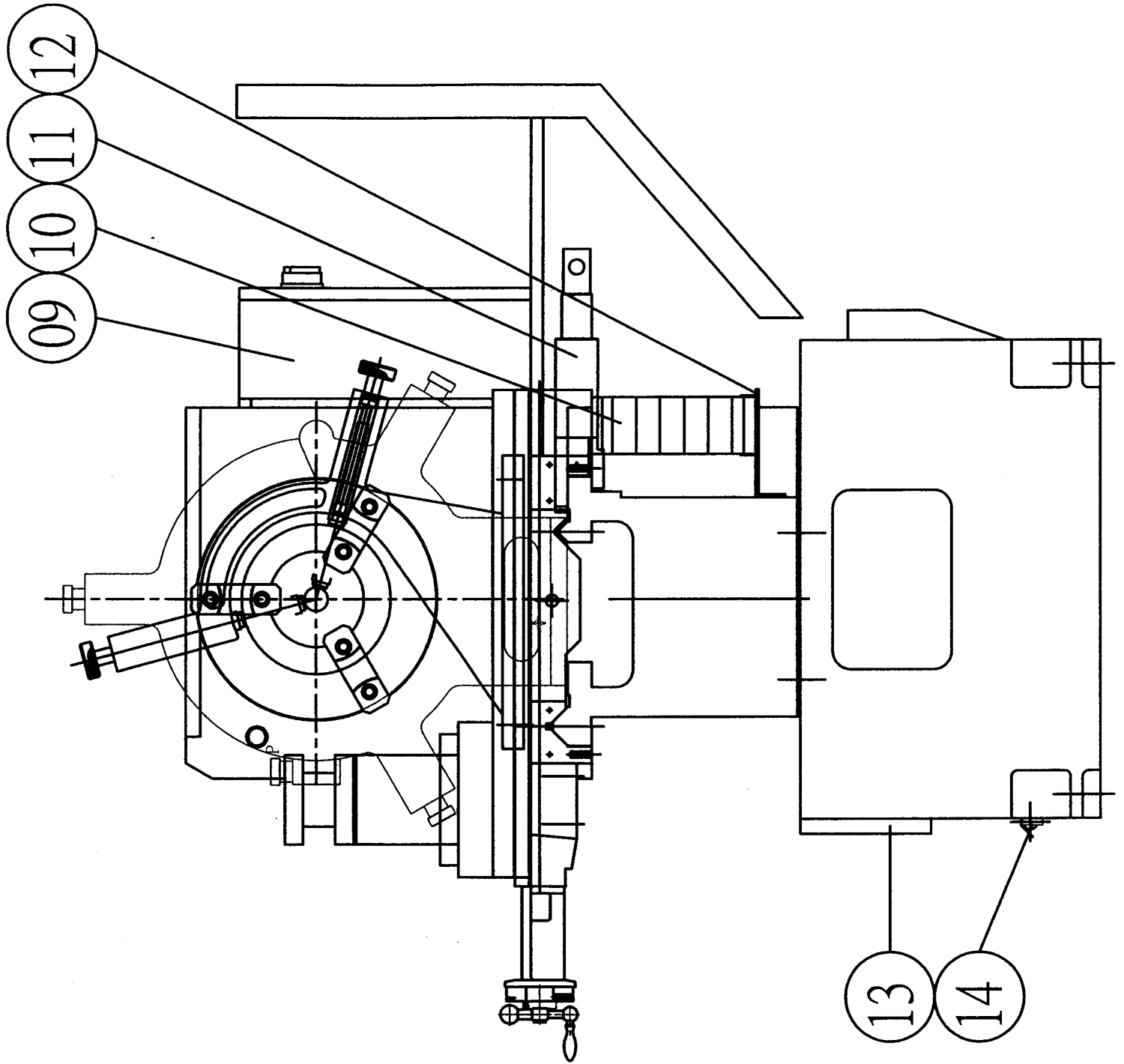

Bed, Sheet Metal & Other Accessories

Serial No.	Part No.	Description	Q'ty
1	33BA-001	Side cover for headstock	1
2		3 jaw scroll chuck SK-16"	1
3	33BA-002	Coolant tank w/pump-front	1
4		Steady rest	1
5		Follow rest	1
6	(H205)	4 ways tool post 150-250L	1
7	33BA-003	Follow-able splash guard	1
8	33BA-004	Coolant tank-back	1
9	33BA-005	Electric cabinet	1
10	33BA-006	Retractable wire encasing	1
11		Taper turning attachment holding bracket	1
12	33BA-007	Support bracket for wire encasing	1
13	33BA-008	Front cover plate	1
14	33BA-009	Brake pedal	1

Steady Rest

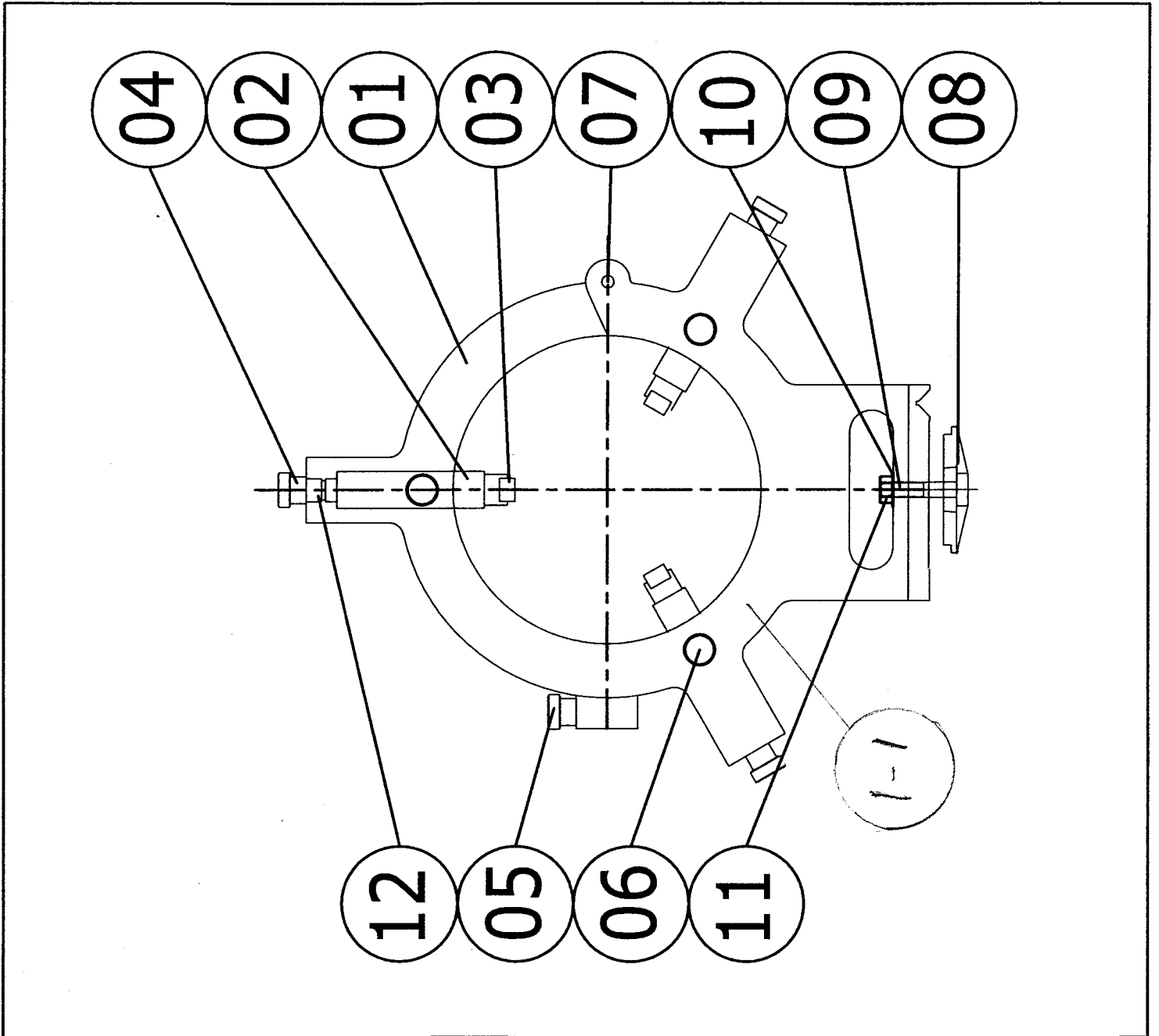

Steady Rest

Serial No.	Part No.	Description	Q'ty
1	33SR-001	Steady rest housing-top	1
1-1	33SR-002	Steady rest housing-lower	1
2	33SR-003	Roller shaft	3
3	33SR-004	Shaft roller	3
4	33SR-005	Adjusting knob	3
5	33SR-006	Housings tighten knob	1
6	33SR-007	Shaft locating screw	3
7	33SR-008	Housings connecting screw	1
8	25T-015100	Locating plate	1
9	3/8"-L4	Square head cap screw	1
10	20-37-4	Square washer	1
11	3/8"	Hex nut	1
12	33SR-009	Adjusting shaft	1

Follow Rest

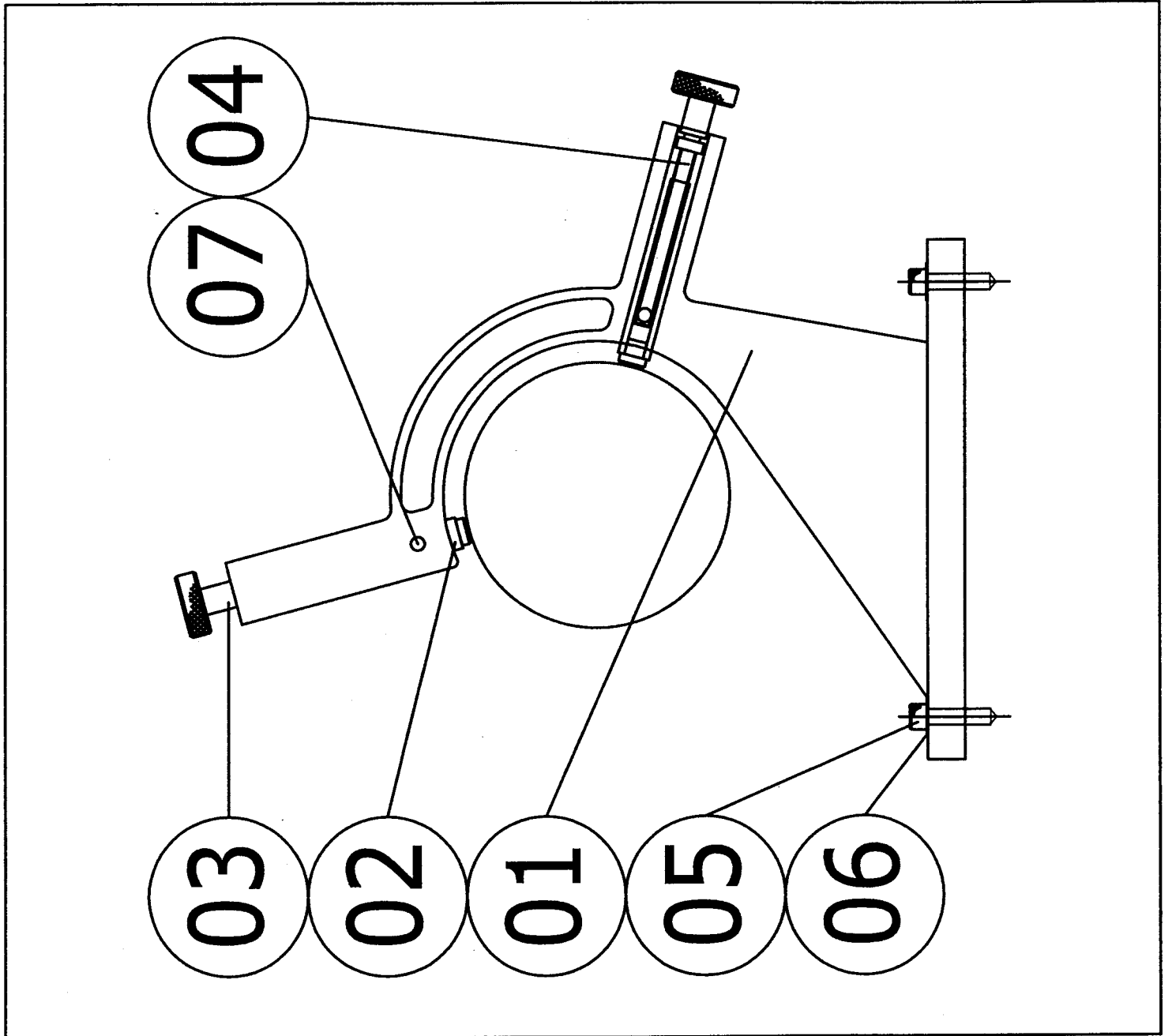

Follow Rest

Serial No.	Part No.	Description	Q'ty
1	33FR-001	Follow rest housing	1
2	33FR-002	Shaft with brass tip	2
3	33FR-003	Adjust knob	2
4	33FR-004	Shaft screw	2
5	M16*L60	Socket head cap screw	2
6	M16	Washer	2
7		Socket head set screw	2

Taper Turning Attachment

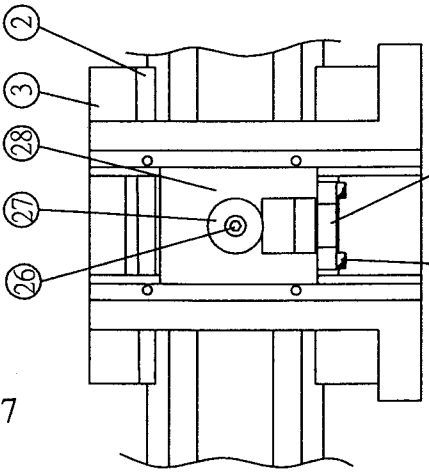
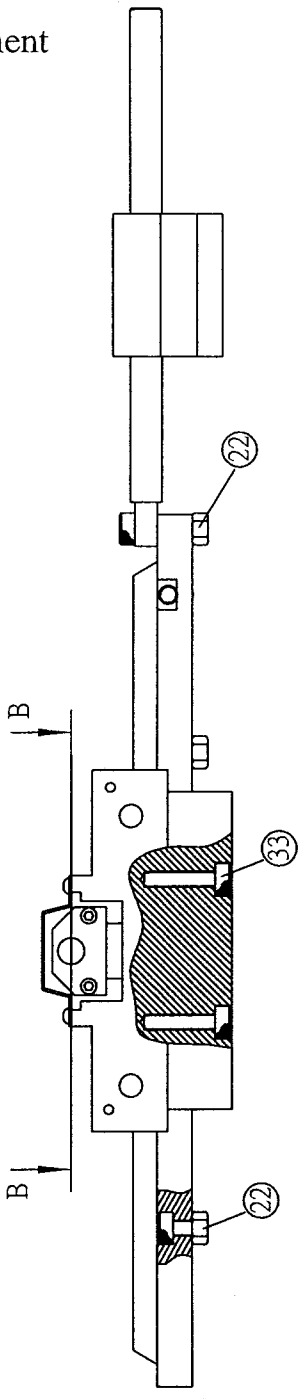
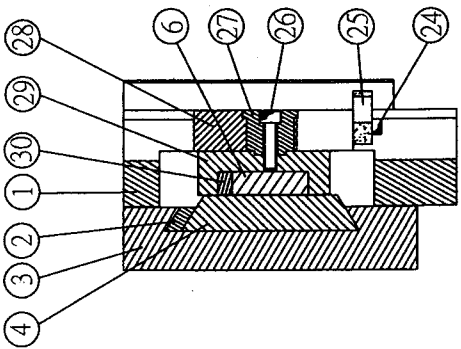
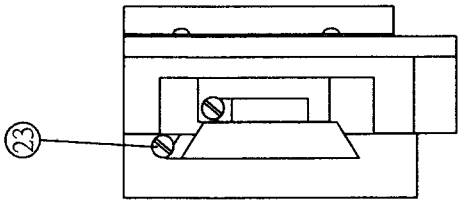
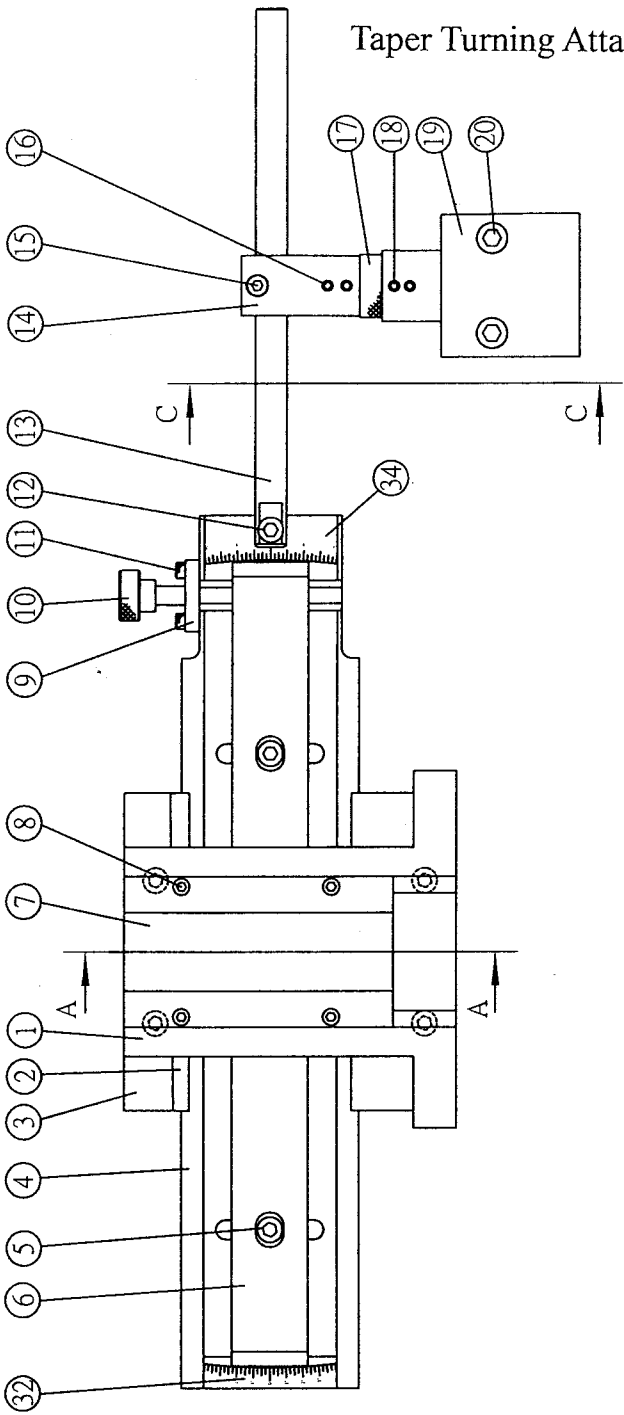

A-A剖視

C-C剖視

B-B剖視

Taper Turning Attachment

Serial No.	Part No.	Description	Q'ty
1	33TA-001	Taper attachment body	1
2	33TA-002	Gib-taper turning attachment	1
3	33TA-003	Top slide casting	1
4	33TA-004	Sliding body	1
5	33TA-005	Socket head cap screw	2
6	33TA-006	Rotating/sliding plate	1
7	33TA-007	Top cover	1
8	33TA-008	Round head cap screw +	4
9	33TA-009	Locating plate	1
10	33TA-010	Screw with knob	1
11	33TA-011	Socket head cap screw	2
12	33TA-012	Socket head cap screw	1
13	33TA-013	Connecting shaft	1
14	33TA-014	Connecting bracket	1
15	33TA-015	Socket head cap screw	1
16	33TA-016	Socket cap set screw	2
17	33TA-017	Dual side connecting shaft	1
18	33TA-018	Socket cap set screw	2
19	33TA-019	Shaft locating bracket	1
20	33TA-020	Socket head cap screw	2
21	33TA-021	Socket cap set screw	1
22	33TA-022	Hex nut	2
23	33TA-023	Gib screw-taper attachment	2
24	33TA-024	Socket head cap screw	4
25	33TA-025	Screw connecting bracket	1
26	33TA-026	Socket head cap screw	1
27	33TA-027	Sleeve	1
28	33TA-028	Connecting plate	1
29	33TA-029	Plate	1
30	33TA-030	Gib	1