

Productivity Packages

For ACER Engine Lathes
& R8 Manual Mills



Made In U.S.A.

Super Quick Change - First Time Buyer's Set

Set Part No.	01058	01060	01062
Tool Post	SDN30BXA	SDN35CXA	SDN40CA
Holders	D30BXA-1 D30BXA-2 D30BXA-881 D30BXA-7-71C	D35CXA-1 D35CXA-2 D35CXA-881 D35CXA-7-71C	D40CA-1 D40CA-2 D40CA-881 D40CA-7-71C
FREE TOOLS	STNCR10-2A STCMB08-2 SGIH19-2 NL50R	STNCR12-3B STCMB10-2 SGIH26-3 NL75R	STNCR64-3D STCMB12-3 SGIH26-3 NL75R
FREE INSERTS	TCMT-21.51-UM-DHCP25 TCMT-21.52-UM-DHCP25 SGTN-2-DVP656 TNMC-32NV-DVP656 111R-A60-DVP656	TCMT-21.51-UM-DHCP25 TCMT-32.52-UM-DHCP25 SGTN-3-DVP656 TNMC-32NV-DVP656 161R-A60-DVP656	TCMT-32.51-UM-DHCP25 TCMT-32.52-UM-DHCP25 SGTN-3-DVP656 TNMC-32NV-DVP656 161R-A60-DVP656
Tool Capacity	5/8"	3/4"	1"
ACER Lathe	13" and 14"	17"	21"
Price	\$764.54	\$961.80	\$1176.85

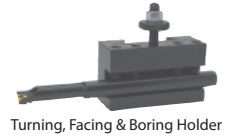
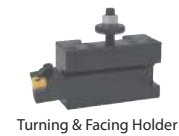

FREE TOOLS & INSERTS

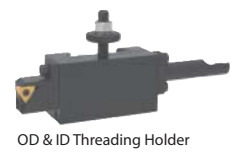
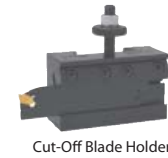

Super Quick Change - 5 Piece Turning Set

Set Part No.	01015	01016	01017	01018
Tool Post	SDN30BXA	SDN35CXA	SDN40CA	SDN50DA
Holders	(2) D30BXA-1 (2) D30BXA-2	(2) D35CXA-1 (2) D35CXA-2	(2) D40CA-1 (2) D40CA-2	(2) D50DA-1 (2) D50DA-2
Tool Capacity	5/8"	3/4"	1"	1 1/4"
Acer Lathe	13" and 14"	17"	21"	24" and 29"
Price	\$600.67	\$817.61	\$1032.02	\$1533.34

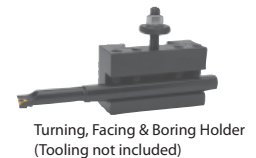
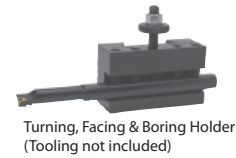

Super Quick Change - 7 Piece Basic Sets

Set Part No.	01031	01033	01035	01037*
Tool Post	SDN30BXA	SDN35CXA	SDN40CA	SDN50DA
Holders	(2) D30BXA-1 (1) D30BXA-2 (1) D30BXA-881 (1) D30BXA-7-71C (1) D30BXA-4-CNC	(2) D35CXA-1 (1) D35CXA-2 (1) D35CXA-881 (1) D35CXA-7-71C (1) D35CXA-4-CNC	(2) D40CA-1 (1) D40CA-2 (1) D40CA-881 (1) D40CA-7-71C (1) D40CA-4-CNC	(2) D50DA-1 (1) D50DA-2 (1) D50DA-7-71C (1) D50DA-4-CNC
Tool Capacity	5/8"	3/4"	1"	1 1/4"
ACER Lathe	13" and 14"	17"	21"	24" and 29"
Price	\$932.25	\$1180.32	\$1442.39	\$1868.79

* 6-Piece Set

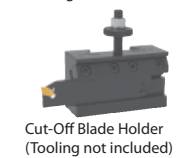
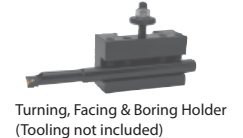

Super Quick Change - 9 Piece CNC Sets

Set Part No.	01044	01046	01048	01050*
Tool Post	SDN30BXA	SDN35CXA	SDN40CA	SDN50DA
Holders	(2) D30BXA-1 (2) D30BXA-2 (1) D30BXA-881 (1) D30BXA-5-3 (1) D30BXA-7-71C (1) D30BXA-4-CNC	(2) D35CXA-1 (2) D35CXA-2 (1) D35CXA-881 (1) D35CXA-5-4 (1) D35CXA-7-71C (1) D35CXA-4-CNC	(2) D40CA-1 (2) D40CA-2 (1) D40CA-881 (1) D40CA-5-4 (1) D40CA-7-71C (1) D40CA-4-CNC	(2) D50DA-1 (2) D50DA-2 (1) D50DA-5-5 (1) D50DA-7-71C (1) D50DA-4-CNC
Tool Capacity	5/8"	3/4"	1"	1 1/4"
ACER Lathe	13" and 14"	17"	21"	24" and 29"
Price	\$1107.58	\$1409.01	\$1699.03	\$2276.74

* 8-Piece Set

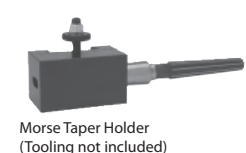
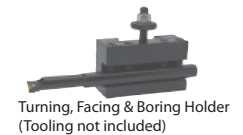

Quadra™ - First Time Buyer's Set			
Set Part No.	00058	00060	00062
Tool Post	QITP30N	QITP35N	QITP40N
Holders	QITP30N-1 QITP30N-2 QITP30N-881 QITP30N-7-71C	QITP35N-1 QITP35N-2 QITP35N-881 QITP35N-7-71C	QITP40N-1 QITP40N-2 QITP40N-881 QITP40N-7-71C
FREE TOOLS	STNCR10-2A STCMB08-2 SGIH19-2 NL50R	STNCR12-3B STCMB10-2 SGIH26-3 NL75R	STNCR64-3D STCMB12-3 SGIH26-3 NL75R
FREE INSERTS	TCMT-21.51-UM-DHCP25 TCMT-21.52-UM-DHCP25 SGTN-2-DVP656 TNMC-32NV-DVP656 11IR-A60-DVP656	TCMT-21.51-UM-DHCP25 TCMT-32.52-UM-DHCP25 SGTN-3-DVP656 TNMC-32NV-DVP656 16IR-A60-DVP656	TCMT-32.51-UM-DHCP25 TCMT-32.52-UM-DHCP25 SGTN-3-DVP656 TNMC-32NV-DVP656 16IR-A60-DVP656
Tool Capacity	5/8"	3/4"	1"
ACER Lathe	13" and 14"	17"	21"
Price	\$1236.86	\$1472.78	\$1724.77

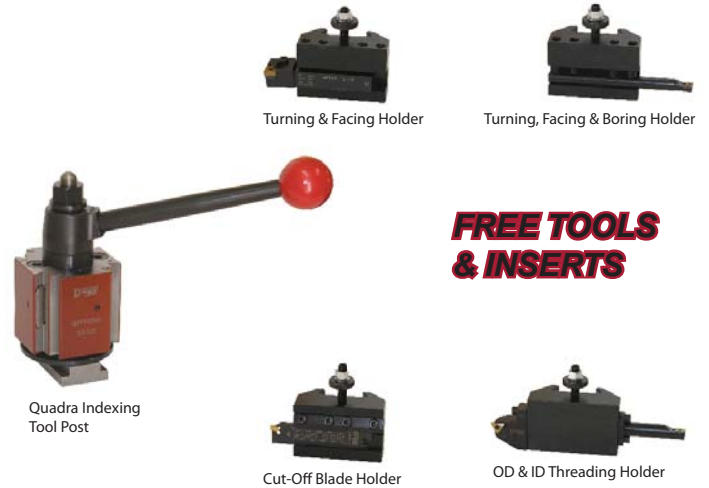

Quadra™ - 5 Piece Turning Set				
Set Part No.	00015	00016	00017	00018
Tool Post	QITP30N	QITP35N	QITP40N	QITP50N
Holders	(2) QITP30N-1 (2) QITP30N-2	(2) QITP35N-1 (2) QITP35N-2	(2) QITP40N-1 (2) QITP40N-2	(2) QITP50N-1 (2) QITP50N-2
Tool Capacity	5/8"	3/4"	1"	1 1/4"
ACER Lathe	13" and 14"	17"	21"	24" and 29"
Price	\$1099.65	\$1348.93	\$1571.68	\$2374.99



Quadra™ - 7 Piece Basic Sets				
Set Part No.	00027	00028	00029	00030*
Tool Post	QITP30N	QITP35N	QITP40N	QITP50N
Holders	(2) QITP30N-1 (1) QITP30N-2 (1) QITP30N-881 (1) QITP30N-7-71C (1) QITP30N-4-CNC	(2) QITP35N-1 (1) QITP35N-2 (1) QITP35N-881 (1) QITP35N-7-71C (1) QITP35N-4-CNC	(2) QITP40N-1 (1) QITP40N-2 (1) QITP40N-881 (1) QITP40N-7-71C (1) QITP40N-4-CNC	(2) QITP50N-1 (1) QITP50N-2 (1) QITP50N-7-71C (1) QITP50N-4-CNC
Tool Capacity	5/8"	3/4"	1"	1 1/4"
ACER Lathe	13" and 14"	17"	21"	24" and 29"
Price	\$1468.09	\$1753.57	\$2053.82	\$2723.71

* 6-Piece Set

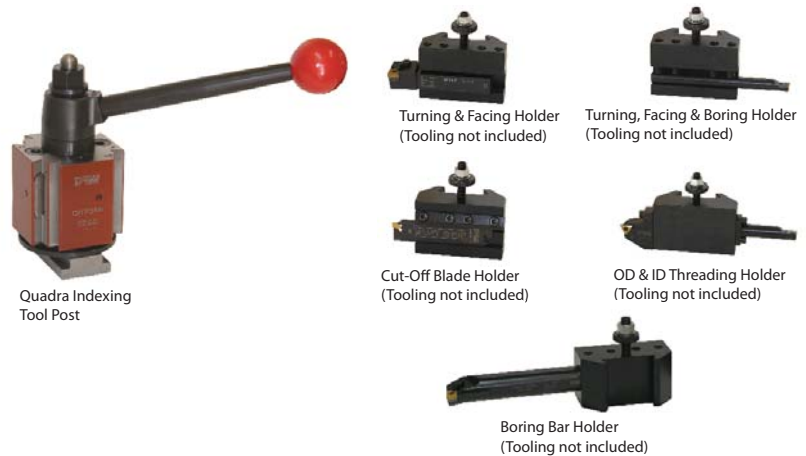

Quadra™ - 9 Piece CNC Sets				
Set Part No.	00044	00046	00048	00050*
Tool Post	QITP30N	QITP35N	QITP40N	QITP50N
Holders	(2) QITP30N-1 (1) QITP30N-2 (1) QITP30N-881 (1) QITP30N-5-2 (1) QITP30N-7-71C (1) QITP30N-4-CNC	(2) QITP35N-1 (2) QITP35N-2 (1) QITP35N-881 (1) QITP35N-5-2 (1) QITP35N-7-71C (1) QITP35N-4-CNC	(2) QITP40N-1 (2) QITP40N-2 (1) QITP40N-881 (1) QITP40N-5-2 (1) QITP40N-7-71C (1) QITP40N-4-CNC	(2) QITP50N-1 (2) QITP50N-2 (1) QITP50N-5-2 (1) QITP50N-7-71C (1) QITP50N-4-CNC
Tool Capacity	5/8"	3/4"	1"	1 1/4"
ACER Lathe	13" and 14"	17"	21"	24" and 29"
Price	\$1685.36	\$2050.86	\$2371.45	\$3200.21

* 8-Piece Set



Precision General Purpose Live Center High Quality • Long Life • Low Price

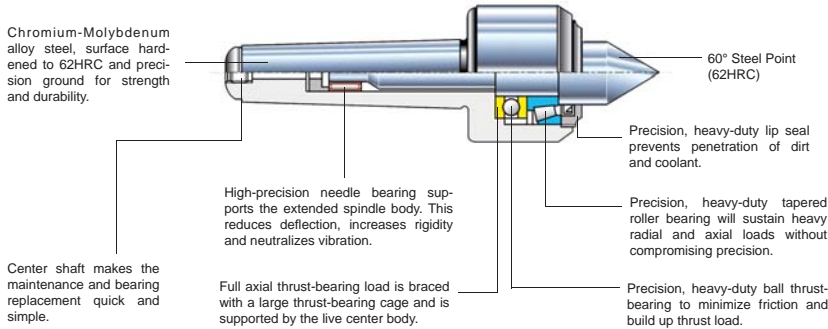

- Three High Speed Precision Bearings
- The Bearings are Permanently Lubricated
- Chromium-Molybdenum Alloy Steel
- Precision Ground, 62HRC Body and Point
- .00015 TIR Concentricity

Precision Live Center Specifications							
UPC No.	Description	Morse Taper	Weight (lb)	Max. RPM	Max. Workpiece Weight (lb)	Thrust Load (lb)	Price
48202	PLC-PRE-S60-MT3	MT3	2.20	5000	575	1145	\$261.92
48203	PLC-PRE-S60-MT4	MT4	3.50	4000	1080	1320	\$336.24
48204	PLC-PRE-S60-MT5	MT5	7.70	3000	1675	1430	\$450.21
48205	PLC-PRE-S60-MT6	MT6	17.60	2500	3390	3300	\$857.32

R8 Right Angle Milling Attachment

Right Angle Attachment Features:

- Designed to simplify Right Angle Work on bed type knee mills by reducing the need of special tooling and difficult fixturing, ideal for cavities and pocket jobs.
- Meehanite Casting Body
- Precision Machined, Heat Treated and Ground Spiral Bevel Gears.
- Sealed High Speed Bearings
- 1.33 to 1 Gear Ratio
- Lubrication Inlet on the side
- Alignment Flats Ground on both sides
- Made in USA

Arbor Support Features:

- Quick-Lock System
- Quick Centerline Adjustment and Lock
- Double Dovetail Track
- High Speed, Heavy Duty Precision Needle Bearing for Arbor Running Bushing
- Overarm Adjustment
- Made in USA



Right Angle Attachment Only	
Part No.	04000
Price	\$992.20

4-Piece Right Angle Attachment Kit	
Kit Part No.	40401
Kit Includes	(1) Right Angle Attachment for 3 3/8" R8 Spindle (for R8 tools) (1) Heavy Duty Arbor Support (1) Arbor, 1" Diameter (1) Drawbar
Price	\$2231.85