



Technology • Creativity • Reliability
An Unswerving Commitment to Excellence

E-mill™ 6VK

A Trouble Free Mill



FEATURES:

- The heavy construction main machine body is made from Meehanite casting, weight 4960 lbs.
- Machine comes with heavy duty extra wide box way for crossfeed and kneefeed.
- The saddle and table are hardened elaborately ground.
- For long-lasting accuracy and smooth operation, "Turcite-B" is applied to the surface of the X and Y slideways.
- Acer's advanced E-mill 5VK Head with inverter electronic variable speed.
- Machine provides large working table, 59" x 11 4/5" with extensive travel, 47" x 15". It is the largest in its class!
- Machine can run both single and three phase 220V without using phase converter.

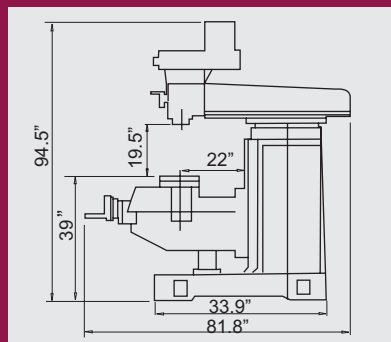
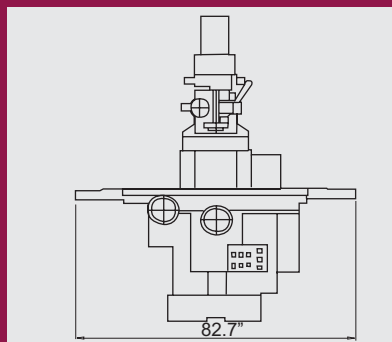

Specifications:	E-mill™ 6VK
Working table (L x W)	59" x 11 4/5"
Longitudinal travel manual	47 1/4"
Cross travel	15"
Vertical travel of knee	19 3/4"
Longitudinal maximum torque	135 in-lbs
Longitudinal power feed	0~210 RPM
Cross-wise maximum torque	170 in-lbs
Cross-wise power feed	0~180 RPM
Spindle speeds(variable)	50~3750 RPM
Spindle taper	NT #40
Head move right to left	90°
Quill travel	5"
Ram travel	16 8/9"
Ram swivel	360°
Spindle nose to table surface distance	3 2/7"~19 2/5"
Power quill feed (in/rev)	0.0015"/0.003"/0.006"
Spindle motor	5HP
Knee vertical feed motor	2 HP 6P
Coolant pump	1/8 HP
Net weight	4960 lbs.
Machine dimensions (L x W x H)	83" x 82" x 95"
Packing dimensions (L x W x H)	89" x 80" x 81"

Note: The manufacturer reserves the right to modify the design, specifications, mechanisms, etc. to improve the performance of machine without notice. All the specifications shown above are for reference only.

STANDARD ACCESSORIES:

- Coolant System
- Halogen Light
- X & Y axes with Power Feeds
- Motorized Knee for rapid up and down
- Automatic Lubrication System
- Tool Box with Tools
- Chip Pan
- Safety Handwheels with Handles
- Electric Cabinet and Ergonomic Control Panel

Website: <http://www.aceronline.net> <http://www.acerlinks.com>

SPRINGWOOD INDUSTRIAL, INC.

1062 N. Kraemer Place
 Anaheim, CA 92806
 Tel: (714) 632-9701
 Fax: (714) 632-9730
 E-mail: info@aceronline.net

KLIM INDUSTRIAL, INC.

244 N. Randolphville Rd.
 Piscataway, NJ 08854
 Tel: (732) 752-9100
 Fax: (732) 752-9101
 E-mail: acer_klim@yahoo.com

YA-GIN MACHINE TOOL MANUFACTURING INC.

No. 101, 506 Lane, Seng-Tso Rd.,
 Seng-Kang District, Taichung City, Taiwan
 Tel: 886-4-2520-4120
 Fax: 886-4-2520-4123
 E-mail: info@acerlinks.com