

Examples Manual

Lathe model

INDEX

Tools	1
Tool calibration	2
General examples	5
Canned cycles	11
«C» axis programming	33
Profile Editor	37
User screen customizing programs	43

WARNING



The cutting speeds and feedrates appearing in this manual are only approximate, they may vary depending on the material of the part and the tools used. When machining one of the parts of these examples, use the speeds recommended by the tool manufacturer.

The tool number will also be different depending on the machine.

===== 0 =====

The information described in this manual may be subject to variations due to technical modifications.

FAGOR AUTOMATION, S.Coop. Ltda. reserves the right to modify the contents of the manual without prior notice.

TOOLS

List of tools used in these examples:

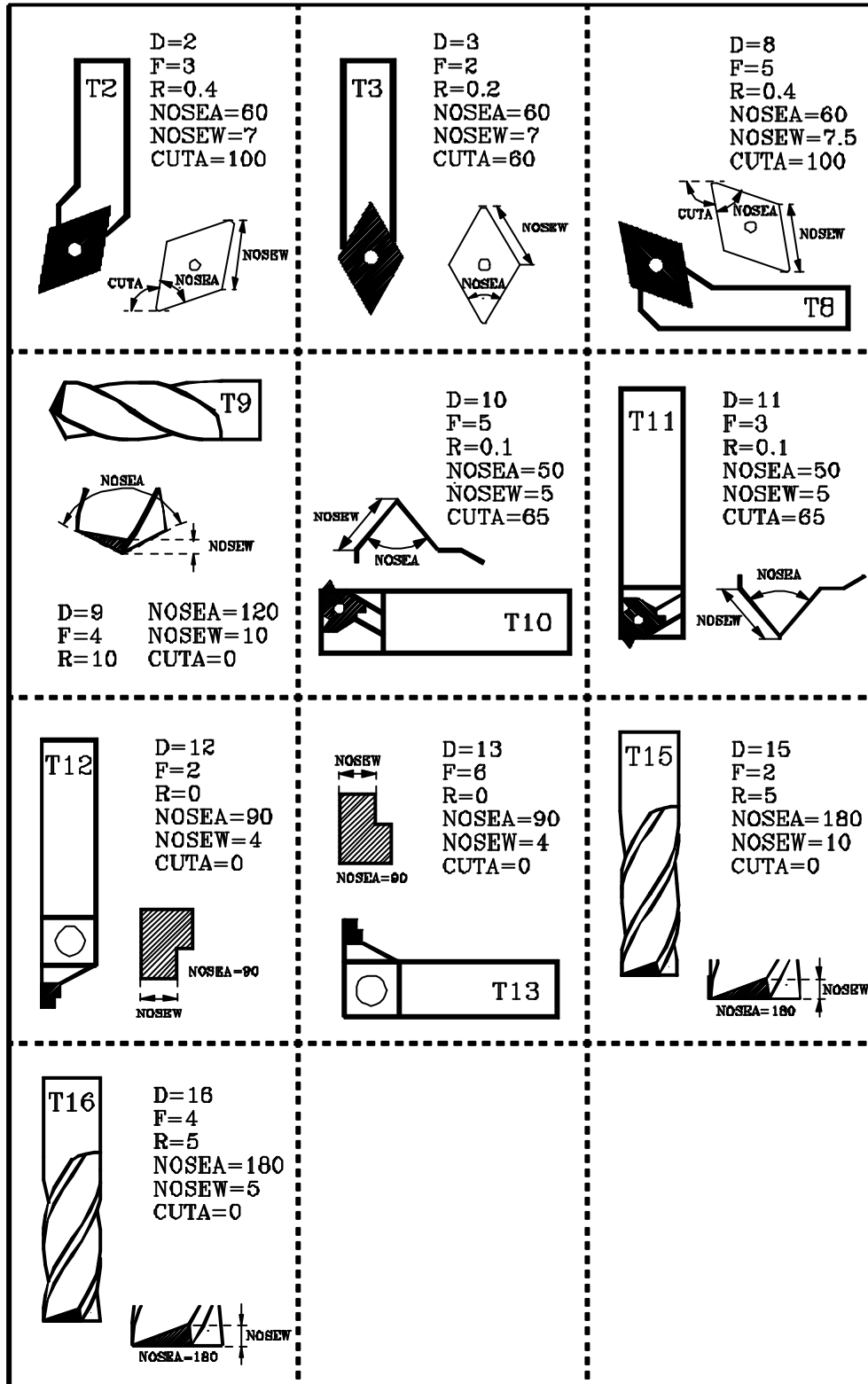

TOOL CALIBRATION

Example of how to calibrate tool T2 using a part of known dimensions (diameter: 60 mm, length: 100 mm).

Note: The X axis operates in diameter.

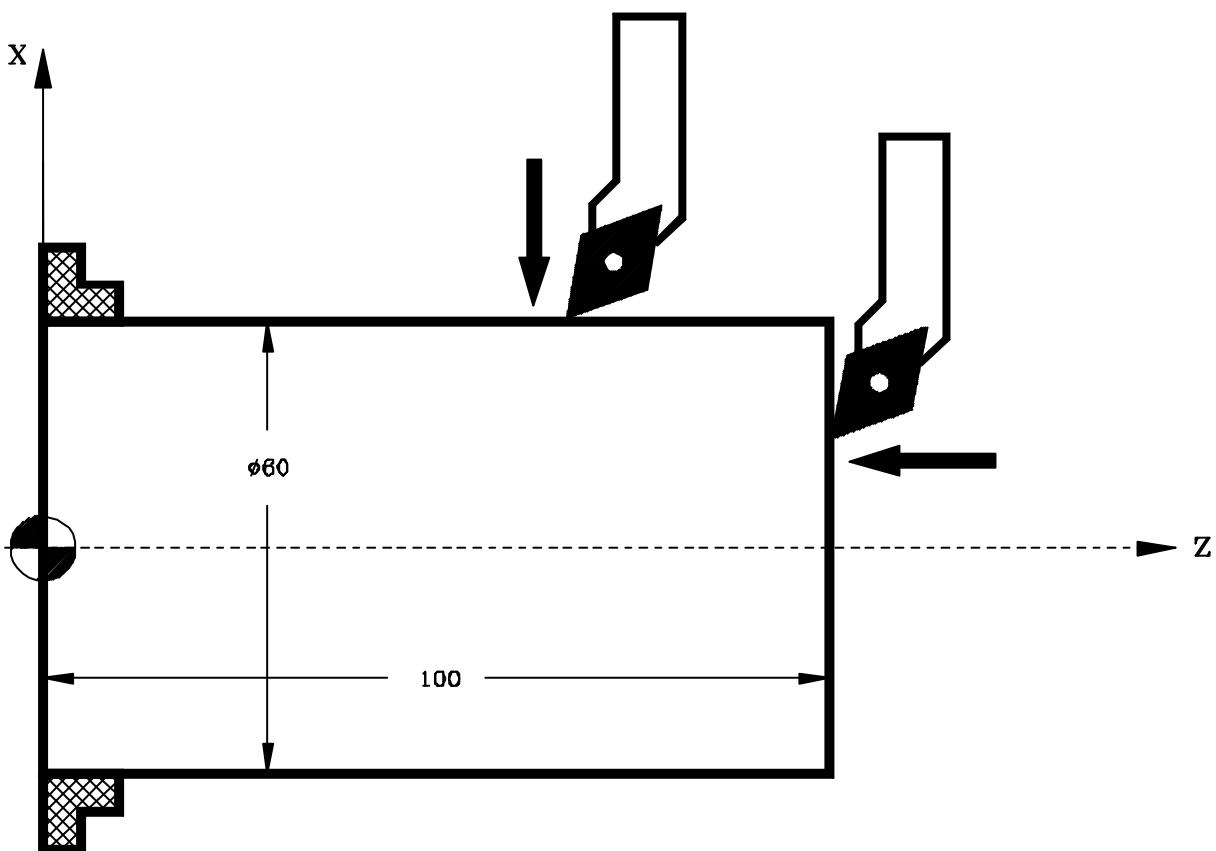
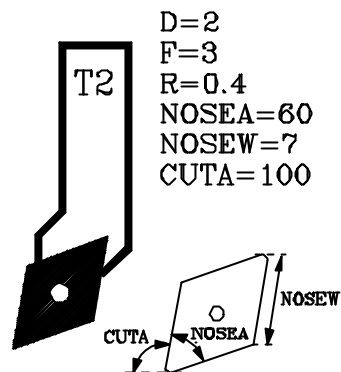

Calibrating procedure

1. Edit the tool and tool offset tables with all the data known for each tool.

Tool table: T2 D2 F0 N0 R0
 Tool offset table: D2 X0 Z0 R0.4 F3 I0 K0
 Tool geometry table T2 NOSEA 60 NOSEW 7 CUTA 100

2. Select the tool and tool offset to be calibrated.

Press the softkey sequence: [Main menu] [JOG] [MDI] T2 D2 

3. Select the tool calibration mode and do it along the X axis.

- Press the softkey sequence: [Main menu] [JOG] [Calibration] [+] [X]
- The CNC requests: Preset the X axis:
- Enter tool diameter 60 [Enter]
- The CNC shows the text Tool calibration.
- Move the tool with the JOG keys until touching the part.
- Press the softkey: [Load X axis]
- The CNC shows the text Offset updated.

4. Calibrate the tool along the Z axis.

- Press the softkey: [Z]
- The CNC requests: Preset the Z axis:
- Enter tool length 100 [Enter]
- The CNC shows the text Tool calibration.
- Move the tool with the JOG keys until touching the part.
- Press the softkey: [Load X axis]
- The CNC shows the text Offset updated.

If accessing the tool offset table next ...

Press the softkey sequence: [Main menu] [Tables] [Tool offsets]

... Offset D2 will show, for example, the following values:

D 2 X 57.456 Z 29.312 R 0.4 F 3 I 0 K 0

Note: The values shown by the "X" field are always in radius.

User Notes:

8040T

8055T

Zero offset.	6
Programming in absolute (G90) and incremental (G91) coordinates.	7
Programming of arcs (G02/G03). (Programming in radius).....	8
Programming of arcs (G02/G03). (Programming in diameters)	9
Tangential entry/exit (G37/G38) and corner rounding(G36) with tool radius compensation (G40/G41/G42).	10

Programming examples:

General examples

Zero offset.

Being the Machine Zero point (home: 0.0), the face of the part, point (120,0) is going to be the new Part Zero.

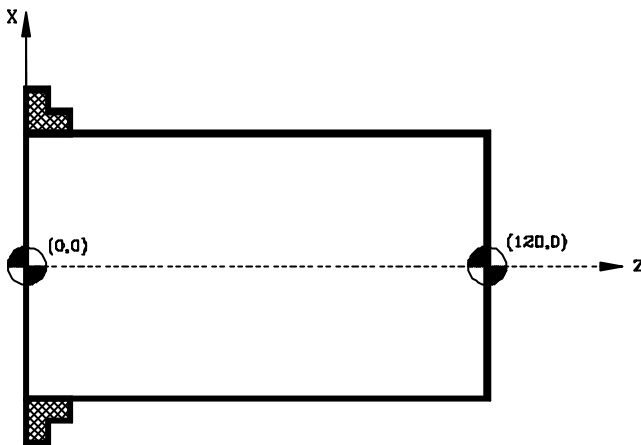

This example shows two ways to do this operation: manual mode and by program. Both methods use zero offset G54.

Manual mode:

1. Select the zero offset table.

Press the sequence of keys and softkeys: [Main menu] [Tables] [Zero offsets]

2. Edit the table for zero offset G54.

Press the sequence of keys and softkeys: [Edit] G54 X0 Z120 [Enter]

3. Select zero offset G54.

Press the sequence of keys and softkeys: [Main menu] [JOG] [MDI] G54 

By program:

One of the following methods must be used.

- Execute, in MDI mode, the following program blocks and then execute the part-program.
- Edit a program with the following blocks and execute it before the part-program.
- Include the following blocks at the beginning of the machining program.

Program blocks.

(ORGX54=0, ORGZ54=120)Assigns the values X0 Z120 to the G54 zero offset table.
 G54Selects and applies zero offset G54.

Programming in absolute (G90) and incremental (G91) coordinates.

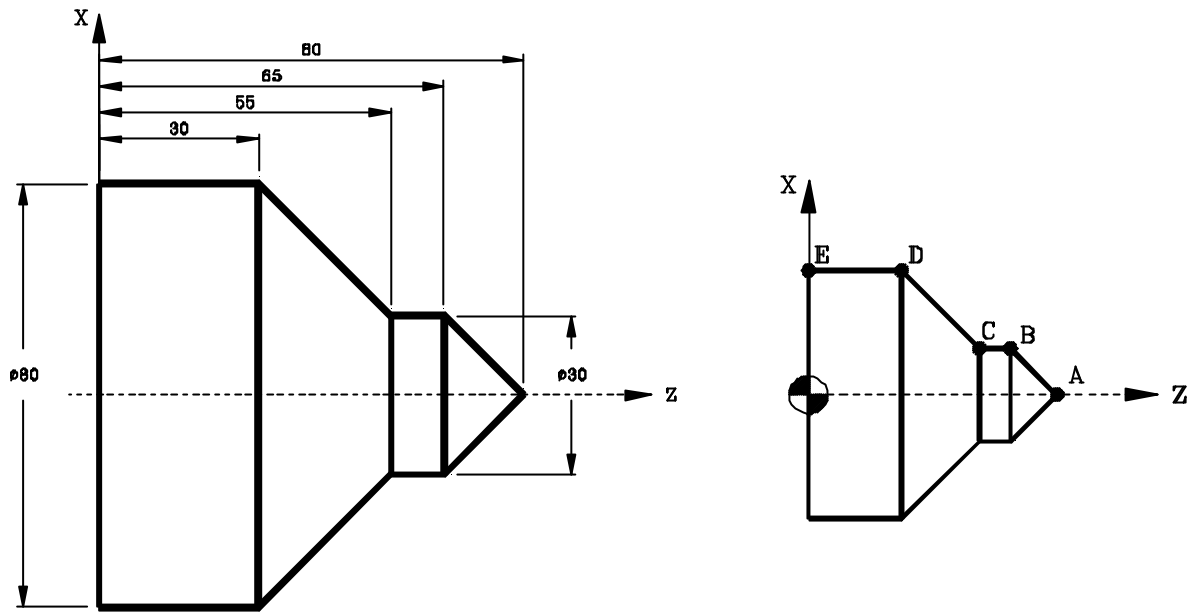

Programming in radius

Absolute coordinates (G90)

```
G90 G95 G96 F0.15 S180 T2 D2 M4 M41
G0 X50 Z100
G1 X0 Z80 ..... Point A
G1 X15 Z65 ..... Section A-B
Z55 ..... Section B-C
X40 Z30 ..... Section C-D
Z0 ..... Section D-E
G0 X50 Z100
M30
```

Incremental coordinates (G91)

```
G90 G95 G96 F0.15 S180 T2 D2 M4 M41
G0 X50 Z100
G1 X0 Z80 ..... Point A
G1 G91 X15 Z-15 ..... Section A-B
Z-10 ..... Section B-C
X25 Z-25 ..... Section C-D
Z-30 ..... Section D-E
G0 G90 X50 Z100
M30
```

Programming in diameters

Absolute coordinates (G90)

```
G90 G95 G96 F0.15 S180 T2 D2 M4 M41
G0 X100 Z100
G1 X0 Z80 ..... Point A
G1 X30 Z65 ..... Section A-B
Z55 ..... Section B-C
X80 Z30 ..... Section C-D
Z0 ..... Section D-E
G0 X100 Z100
M30
```

Incremental coordinates (G91)

```
G90 G95 G96 F0.15 S180 T2 D2 M4 M41
G0 X100 Z100
G1 X0 Z80 ..... Point A
G1 G91 X30 Z-15 ..... Section A-B
Z-10 ..... Section B-C
X50 Z-25 ..... Section C-D
Z-30 ..... Section D-E
G0 G90 X100 Z100
M30
```

Programming of arcs (G02/G03). (Programming in radius)

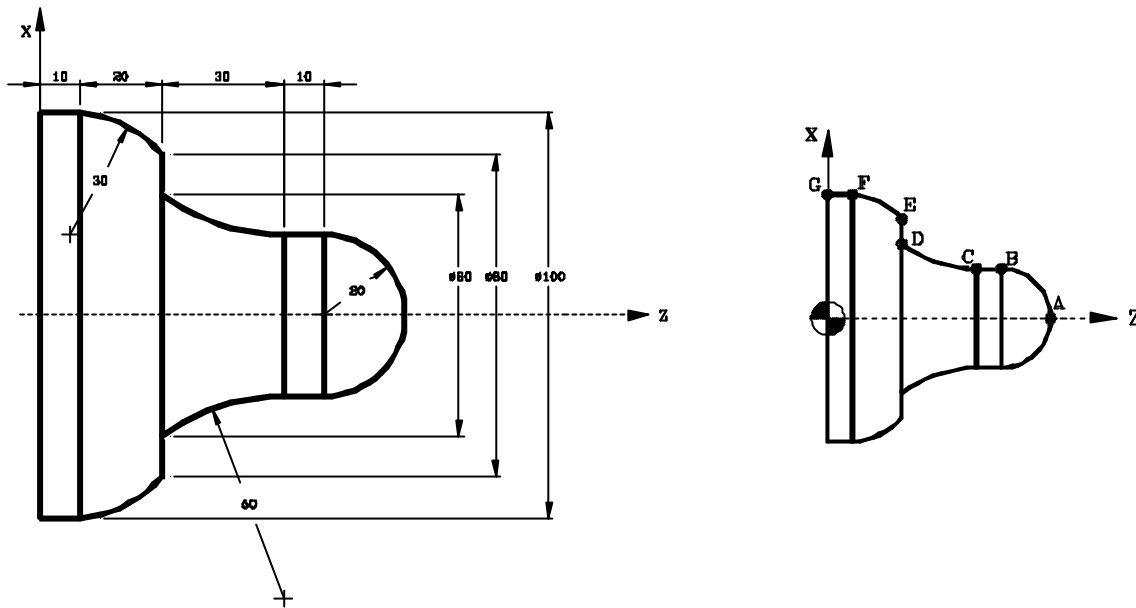

Programming the arc center

Absolute coordinates (G90)

```
G90 G95 G96 F0.15 S180 T2 D2 M4
G0 X60 Z120
G1 X0 Z90 ..... Point A
G3 X20 Z70 I0 K-20 ..... Section A-B
G1 Z60 ..... Section B-C
G2 X30 Z30 I50 K0 ..... Section C-D
G1 X40 ..... Section D-E
G3 X50 Z10 I-19.9 K-22.45 .. Section E-F
G1 Z0 ..... Section F-G
G0 X60 Z120
M30
```

Incremental coordinates (G91)

```
G90 G95 G96 F0.15 S180 T2 D2 M4
G0 X60 Z120
G1 X0 Z90 ..... Point A
G91 G3 X20 Z-20 I0 K-20 ..... Section A-B
G1 Z-10 ..... Section B-C
G2 X10 Z-30 I50 K0 ..... Section C-D
G1 X10 ..... Section D-E
G3 X10 Z-20 I-19.9 K-22.45 . Section E-F
G1 Z-10 ..... Section F-G
G0 G90 X60 Z120
M30
```

Programming the arc radius

Absolute coordinates (G90)

```
G90 G95 G96 F0.15 S180 T2 D2 M4
G0 X60 Z120
G1 X0 Z90 ..... Point A
G3 X20 Z70 R20 ..... Section A-B
G1 Z60 ..... Section B-C
G2 X30 Z30 R50 ..... Section C-D
G1 X40 ..... Section D-E
G3 X50 Z10 R30 ..... Section E-F
G1 Z0 ..... Section F-G
G0 X60 Z120
M30
```

Incremental coordinates (G91)

```
G90 G95 G96 F0.15 S180 T2 D2 M4
G0 X60 Z120
G1 X0 Z90 ..... Point A
G91 G3 X20 Z-20 R20 ..... Section A-B
G1 Z-10 ..... Section B-C
G2 X10 Z-30 R50 ..... Section C-D
G1 X10 ..... Section D-E
G3 X10 Z-20 R30 ..... Section E-F
G1 Z-10 ..... Section F-G
G0 G90 X60 Z120
M30
```

Programming of arcs (G02/G03). (Programming in diameters)

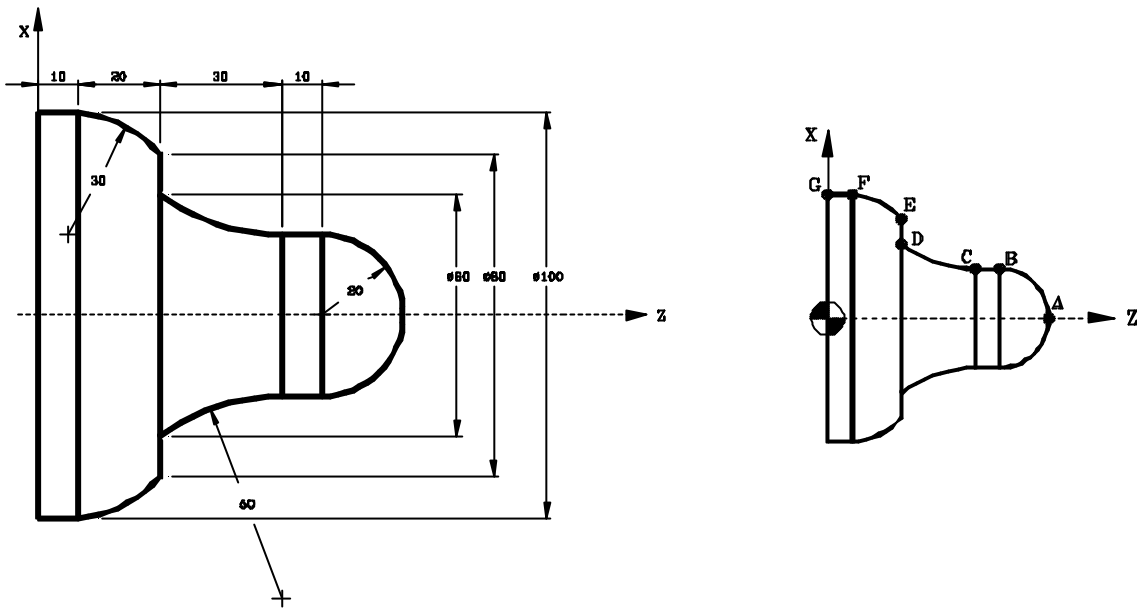

Programming the arc center

Absolute coordinates (G90)

```
G90 G95 G96 F0.15 S180 T2 D2 M4
G0 X120 Z120
G1 X0 Z90 ..... Point A
G3 X40 Z70 I0 K-20 ..... Section A-B
G1 Z60 ..... Section B-C
G2 X60 Z30 I50 K0 ..... Section C-D
G1 X80 ..... Section D-E
G3 X100 Z10 I-19.9 K-22.45 Section E-F
G1 Z0 ..... Section F-G
G0 X120 Z120
M30
```

Incremental coordinates (G91)

```
G90 G95 G96 F0.15 S180 T2 D2 M4
G0 X120 Z120
G1 X0 Z90 ..... Point A
G91 G3 X40 Z-20 I0 K-20 ..... Section A-B
G1 Z-10 ..... Section B-C
G2 X20 Z-30 I50 K0 ..... Section C-D
G1 X20 ..... Section D-E
G3 X20 Z-20 I-19.9 K-22.45 Section E-F
G1 Z-10 ..... Section F-G
G0 G90 X60 Z120
M30
```

Programming the arc radius

Absolute coordinates (G90)

```
G90 G95 G96 F0.15 S180 T2 D2 M4
G0 X120 Z120
G1 X0 Z90 ..... Point A
G3 X40 Z70 R20 ..... Section A-B
G1 Z60 ..... Section B-C
G2 X60 Z30 R50 ..... Section C-D
G1 X80 ..... Section D-E
G3 X100 Z10 R30 ..... Section E-F
G1 Z0 ..... Section F-G
G0 X120 Z120
M30
```

Incremental coordinates (G91)

```
G90 G95 G96 F0.15 S180 T2 D2 M4
G0 X120 Z120
G1 X0 Z90 ..... Point A
G91 G3 X40 Z-20 R20 ..... Section A-B
G1 Z-10 ..... Section B-C
G2 X20 Z-30 R50 ..... Section C-D
G1 X20 ..... Section D-E
G3 X20 Z-20 R30 ..... Section E-F
G1 Z-10 ..... Section F-G
G0 G90 X60 Z120
M30
```

Tangential entry/exit (G37/G38) and corner rounding(G36) with tool radius compensation (G40/G41/G42).

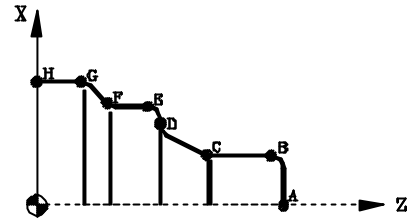
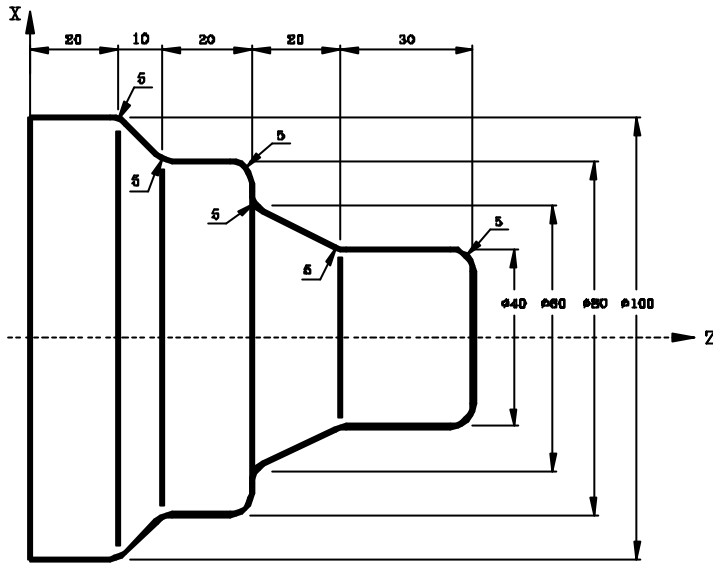

```
G90 G95 G96 F0.15 S180 T2 D2 M4
G0 X120 Z120
G42 X0 ..... Begin tool radius compensation.
G01 G37 R4 X0 Z100 ..... Tangential entry at point A.
G01 G36 R5 X40 ..... Section A-B.
G36 R5 Z70 ..... Section B-C.
G36 R5 X60 Z50 ..... Section C-D.
G36 R5 X80 ..... Section D-E.
G36 R5 Z30 ..... Section E-F.
G36 R5 X100 Z20 ..... Section F-G.
G38 R4 Z0 ..... Section G-H and tangential exit
G0 X120
G40 Z120 ..... End tool radius compensation.
M30
```

Without tool radius compensation, the theoretical tool tip follows the programmed profile. The programmed profile (continuous line) does not coincide with the machined profile (dotted line).

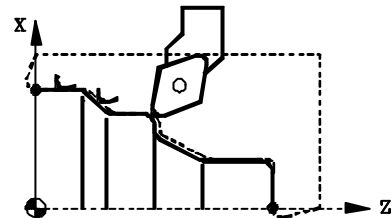

With tool radius compensation, the CNC recalculates the path so the machined profile coincides with the one programmed.

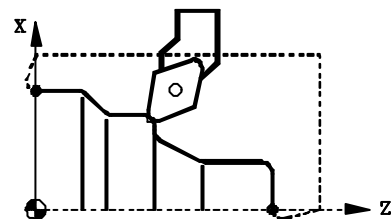

8040T

8055T

Inside turning of arcs and outside turning of straight sections.	12
Inside arc facing and outside straight turning.	14
Inside straight facing and outside arc facing.	16
Inside roughing on the Z axis and outside arc turning.	18
Inside straight turning and outside roughing on the Z axis.	20
Inside and outside roughing on the X axis.	22
Inside and outside taper threading.	24
Inside and outside roughing on X. Outside grooving and threading.	26
Outside pattern repeat. Inside grooving and threading.	28
Inside and outside roughing on the X axis	30

Programming examples: Canned cycles

Inside turning of arcs and outside turning of straight sections.

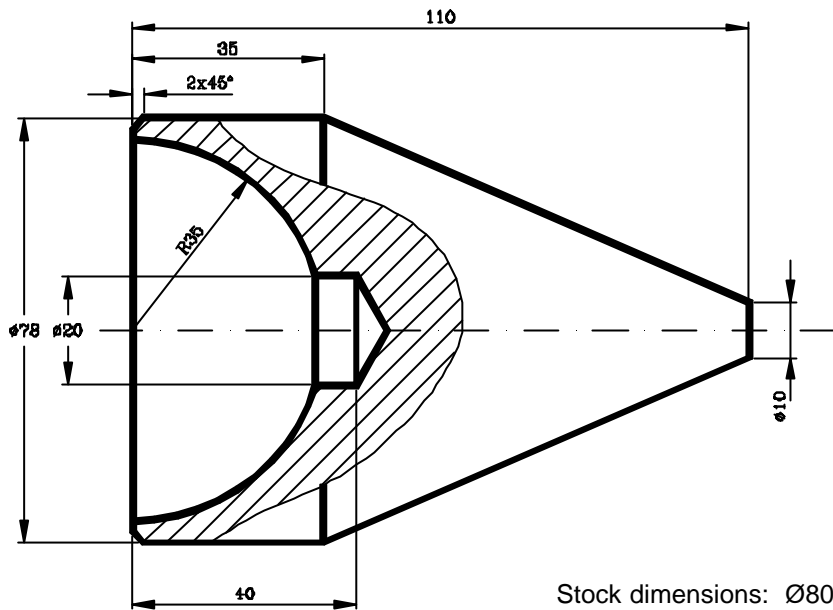

First fixture:

Set part zero

(ORGX54=0, ORGZ54=112)

G54

G92 S2200

Operation 1 (Drilling)

G94 G97 F90 S600 M4

Z150

T9 D9

G0 X0 Z8

G83 X0 Z0 I45.773 B9 D4 K0 H0 C1

G0 Z150

Operation 2 (Inside arc turning)

G95 G96 F0.2 S120 M4

T8 D8

G0 X20 Z20

G1 G41 X18 Z5

G84 X70 Z0 Q20 R-33.541 C2 L0.3 M0.3 H0.1 I-35 K0

G0 G40 Z150

Operation 3 (Facing and outside turning)

G95 G96 F0.2 S180 M4

T2 D2

G0 X90 Z20

G1 X78 Z5

G1 Z-40

G1 X85

G0 Z0

G1 X66

G1 Z5

G1 G42 X72 Z1

G1 X80 Z-3

G0 G40 Z150

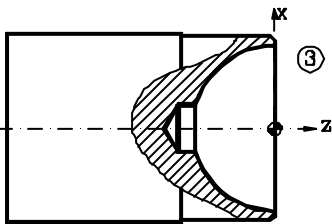
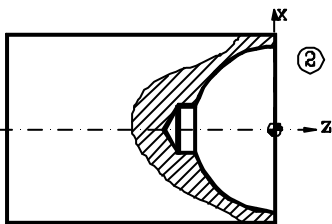
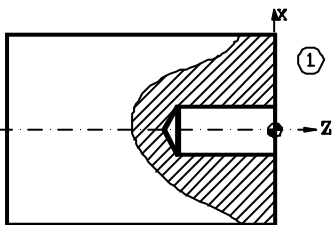

Second fixture:

Set new part zero

```
(MSG "** NEW FIXTURE - REVERSE PART *")
M0 M5
(MSG "")
(ORGX54=0, ORGZ54=110)
G54
G92 S2200
```

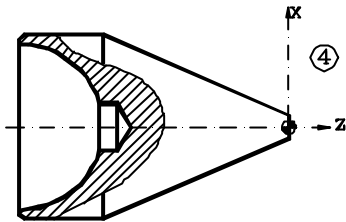

Operation 4 (Taper turning and facing)

```
G95 G96 F0.2 S180 M4
G0 X90 Z20
G1 G42 X84 Z5
G81 X10 Z0 Q78 R-75 C2 L0.3 M0.3 H0.1
G0 G40 X14 Z0
G1 X-0.4
G0 Z150
M30
```

Inside arc facing and outside straight turning.

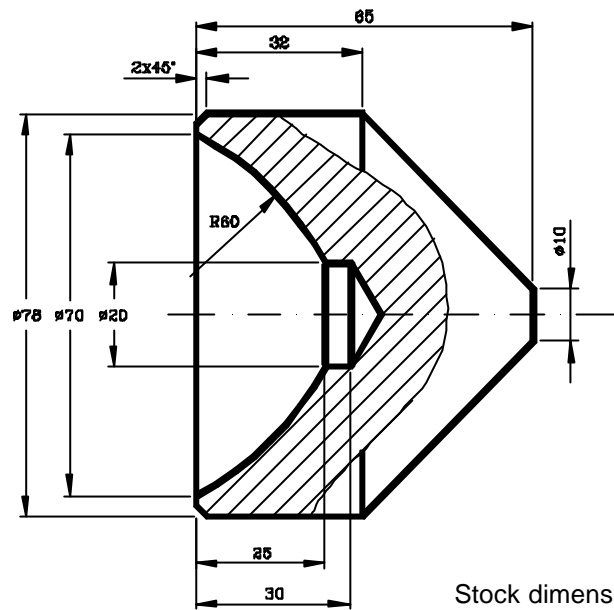

First fixture:

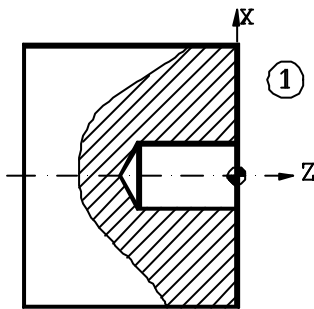

Set part zero

(ORGX54=0, ORGZ54=67)

G54

G92 S2200

Operation 1 (Drilling)

G94 G97 F90 S600 M4

Z150

T9 D9

G0 X0 Z8

G83 X0 Z0 I38.773 B3 D7 K0 H0 C4

G0 Z150

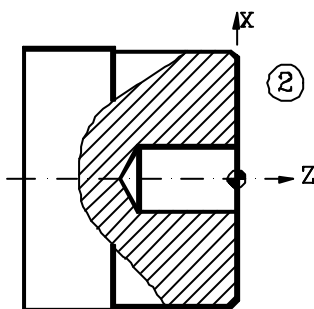

Operation 2 (Facing and outside turning)

G95 G96 F0.2 S180 M4

T2 D2

G0 X90 Z20

G1 X85 Z0

G1 X18

G1 Z5

G0 G42 X72 Z1

G1 X78 Z-2

Z-40

X85

G0 Z150

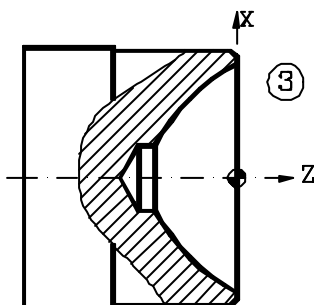

Operation 3 (Inside arc facing)

G95 G96 F0.2 S100 M4

T8 D8

G0 X20 Z20

G1 G42 X17 Z2

G85 X20 Z-25 Q70 R0 C1.4 L0.3 M0.3 H0.1 I-28.043 K53.043

G0 G40 Z150

Second fixture:

Set new part zero

```
(MSG "** NEW FIXTURE - REVERSE PART **")
M0 M5
(MSG "")
(ORGX54=0, ORGZ54=65)
G54
G92 S2200
```

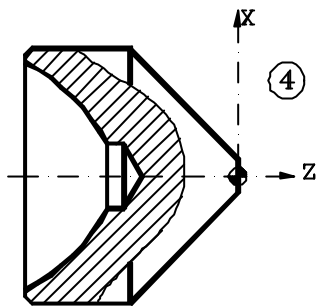

Operation 4 (Outside taper facing)

```
G95 G96 F0.2 S180 M4
T2 D2
G0 X90 Z20
G1 G41 X83 Z5
G82 X78 Z-33 Q10 R0 C2 L0.3 M0.3 H0.1
G0 G40 X14 Z0
G1 X-0.4
G0 Z150
M30
```

Inside straight facing and outside arc facing.

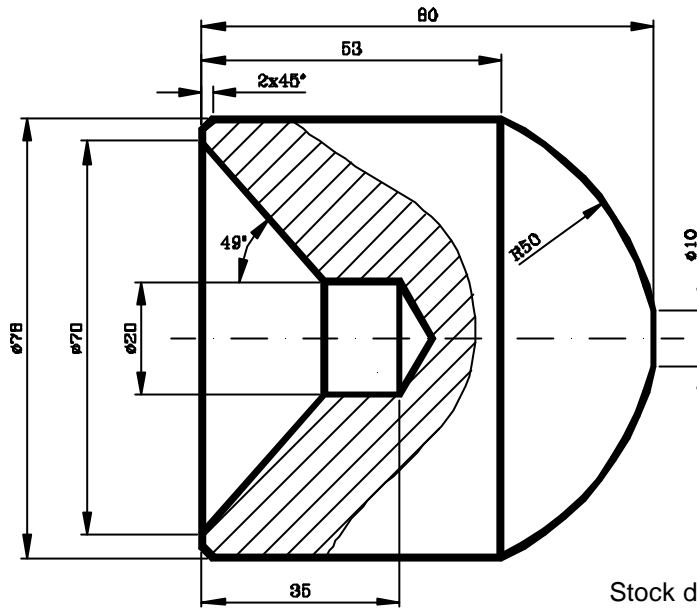

First fixture:

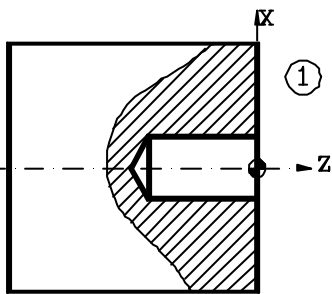

Set part zero

(ORGX54=0, ORGZ54=82)

G54
G92 S2200

Operation 1 (Drilling)

G95 G97 F0.15 S600 M4
Z150
T9 D9
G0 X0 Z8
G83 X0 Z0 I40.773 B3 D7 K10 H0 C4
G0 Z150

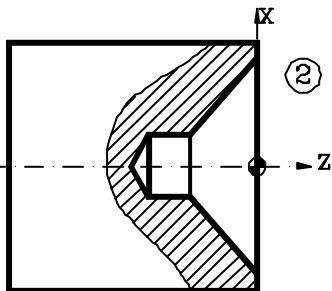

Operation 2 (Inside taper facing)

G95 G96 F0.2 S100 M4
T8 D8
G0 X20 Z20
G1 G42 X18 Z5
G82 X20 Z-21.732 Q70 R0 C2 L0.2 M0.2 F0.15 H0.1
G0 G40 Z150

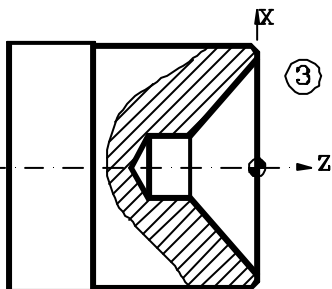

Operation 3 (Facing and outside turning)

G95 G96 F0.2 S180 M4
T2 D2
G0 X90 Z20
G1 X78 Z5
G1 Z-40
G1 X85
G0 Z0
G1 X66
G1 Z5
G1 G42 X72 Z1
G1 X80 Z-3
G0 G40 Z150



Second fixture:

Set new part zero

```
(MSG `` NEW FIXTURE - REVERSE PART ``)
M0 M5
(MSG ``)
(ORGX54=0, ORGZ54=80)
G54
G92 S2200
```

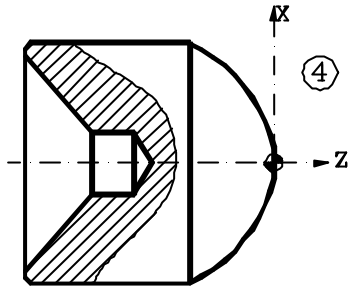

Operation 4 (Outside arc facing)

```
G95 G96 F0.2 S180 M4
T2 D2
G0 X90 Z20
G41 X84 Z5
G85 X78 Z-27 Q10 R0 C1.5 L0.3 M0.3 H0.1 I-45.011 K-21.772
G0 G40 X14 Z0
G1 X-0.4 F0.2
G0 Z150
M30
```

Inside roughing on the Z axis and outside arc turning.

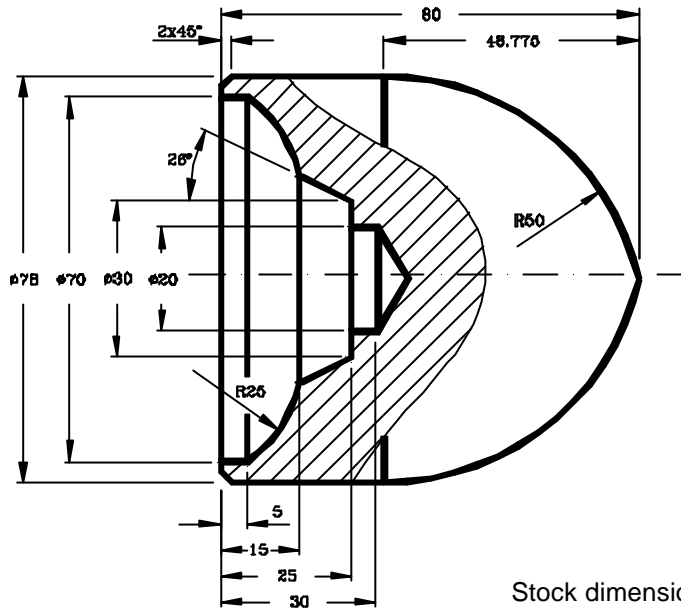

First fixture:

Set part zero

(ORGX54=0, ORGZ54=82)

G54

G92 S2200

Operation 1 (Drilling)

G94 G97 F90 S600 T9 M4

Z150

T9 D9

G0 X0 Z8

G83 X0 Z0 I35.773 B5 D5 K15 H0 C1.5

G0 Z150

Operation 2 (Inside profile facing)

G95 G96 F0.2 S100 M4

T8 D8

G0 X20 Z20

G1 X16 Z5

G69 X20 Z-25 C1.5 L0.3 H0.1 S100 E110

(GOTO N120)

N100 G1 X30 Z-25

X39.755 Z-15

G2 X70 Z-5 I-5.29 K24.434

N110 G1 X70 Z4

N120 G0 Z150

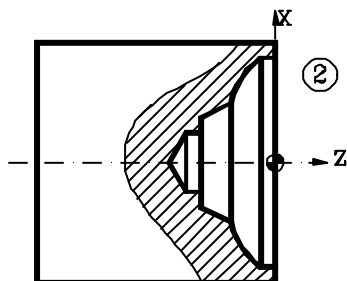
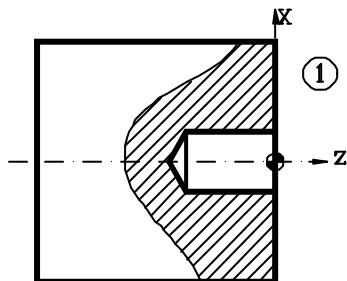

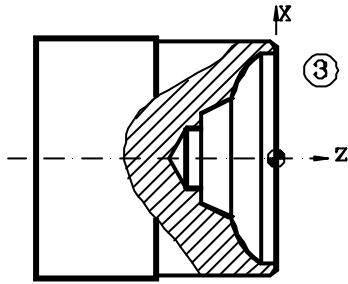

Operation 3 (Facing and outside turning)

```
G95 G96 F0.2 S180 M4
T2 D2
G0 X90 Z20
G1 X78 Z5
G1 Z-40
G1 X85
G0 Z0
G1 X66
G1 Z5
G1 G42 X72 Z1
G1 X80 Z-3
G0 G40 Z150
```

Second fixture:

Set new part zero

```
(MSG "*" NEW FIXTURE - REVERSE PART *")
M0 M5
(MSG "")
(ORGX54=0, ORGZ54=80)
G54
G92 S2200
```

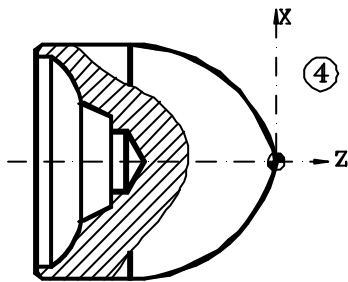

Operation 4 (Outside arc turning)

```
G95 G96 F0.2 S180 M4
T2 D2
G0 X90 Z20
G1 G42 X84 Z5
G84 X0 Z0 Q78 R-48.775 C2 L0.3 M0.3 H0.1 I-11 K-48.775
G0 G40 Z150
M30
```

Inside straight turning and outside roughing on the Z axis.

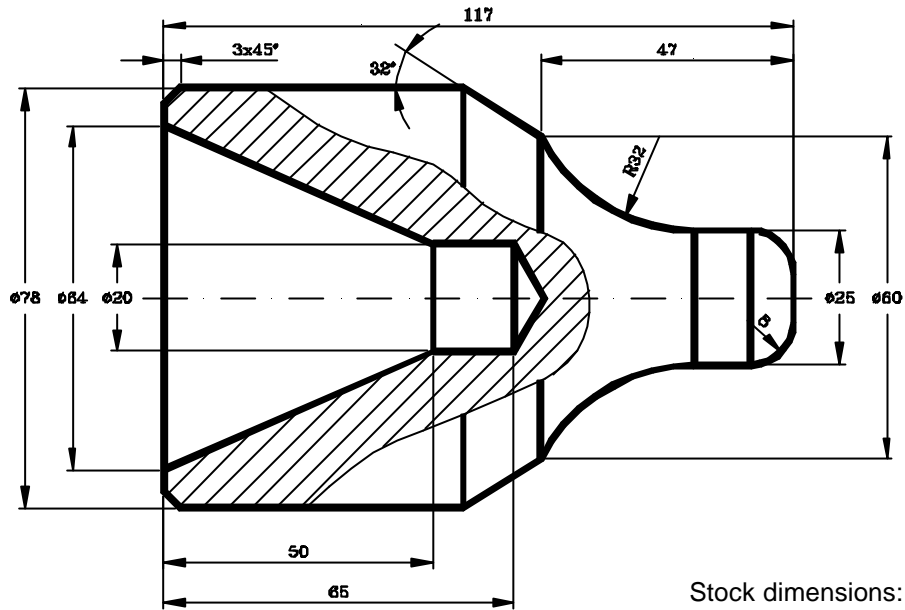

First fixture:

Set part zero

(ORGX54=0, ORGZ54=119)

G54

G92 S2200

Operation 1 (Facing and outside turning)

G95 G96 F0.2 S180 M4

G0 Z150

T2 D2

G0 X90 Z20

G1 X85 Z0

G1 X-0.4

Z5

G0 X78 Z2

G1 Z-60

X85

G0 G41 X80 Z-4

G1 X70 Z1

G0 Z150

Operation 2 (Drilling)

G94 G97 F90 S600 M4

T9 D9

G0 X0 Z5

G83 X0 Z0 I70.773 B8 D4 K1 H0 C1

G0 Z150

Operation 3 (Inside taper turning)

G95 G96 F0.2 S120 M4

T8 D8

G0 G41 X18 Z5

G81 X64 Z0 Q20 R-50 C1.5 L0.3 M0.25 H0.1

G0 Z150

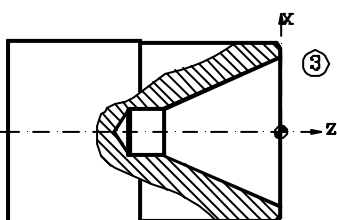
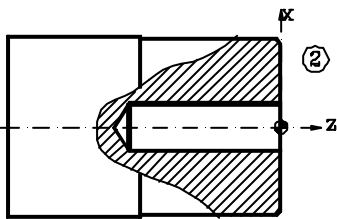
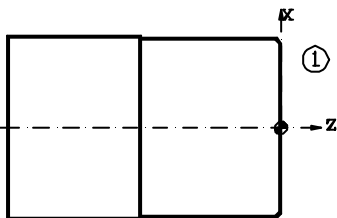

Second fixture:

Set new part zero

```
(MSG ``* NEW FIXTURE - REVERSE PART *``)
M0 M5
(MSG ````)
(ORGX54=0, ORGZ54=117)
G54
G92 S2200
```

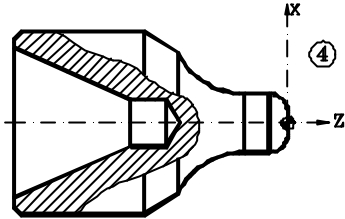

Operation 4 (Outside profile facing)

```
G95 G96 F0.2 S180 M4
T2 D2
G0 X90 Z20
G1 X85 Z5
G69 X78 Z-61.403 C1 L0.3 H0.1 S100 E110
(GOTO N120)
N100 G1 G5 X60 Z-47
      G3 X25 Z-18.474 I14.5 K28.526
      G1 G36 R8 X25 Z0
N110 X-0.4 Z0
N120 G0 Z150
M30
```

Inside and outside roughing on the X axis.

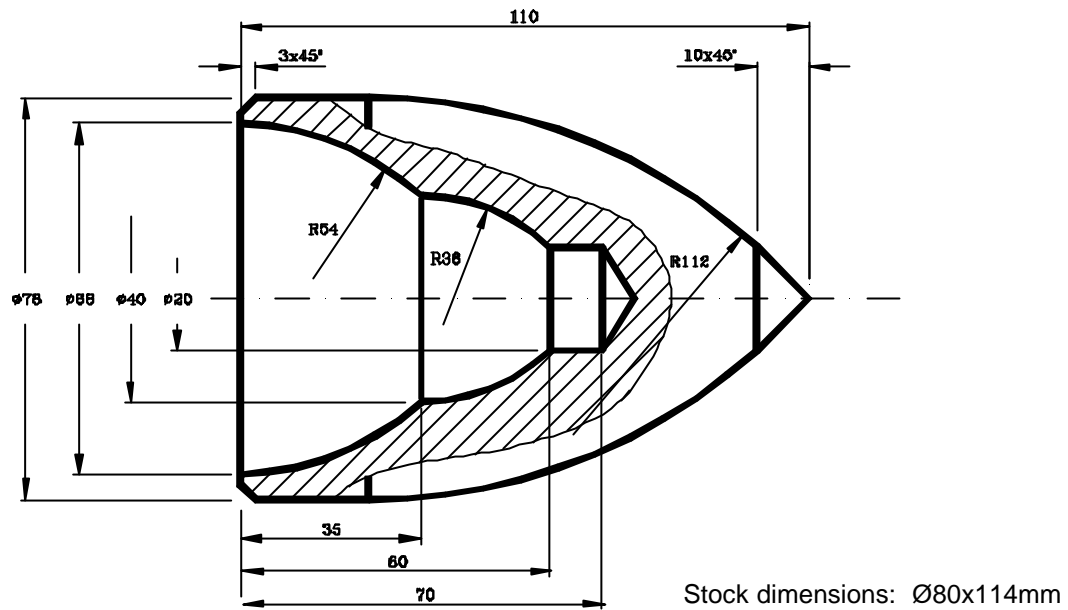

First fixture:

Set part zero

(ORGX54=0, ORGZ54=112)

G54

G92 S2200

Operation 1 (Drilling)

G94 G97 F90 S600 M4

G0 Z150

T9 D9

G0 X0 Z10

G83 X0 Z0 I75.773 B8 D2 K50 H0 C5

G0 Z150

Operation 2 (Facing and outside turning)

G95 G96 F0.2 S180 M4

T2 D2

G0 X78 Z5

G1 Z-60

X85

G0 Z0

G1 X18

G0 Z5

G0 G42 X70 Z1

G1 X80 Z-4

G0 G40 X85 Z150

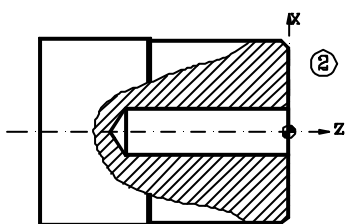
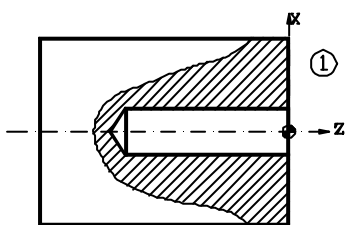

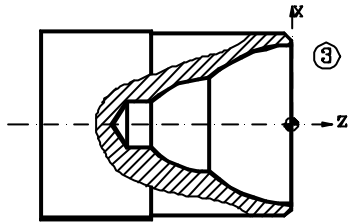

Operation 3 (Inside profile turning)

```
G95 G96 F0.2 S120 M4
T8 D8
G0 X18 Z20
G1 Z5
G68 X68 Z0 C1.5 L0.4 H0 S100 E110
G0 G41 X68 Z1
G5 G1 Z0 F0.1
N100 G3 X40 Z-35 I-53.985 K1.293
N110 G3 X20 Z-60 R36
G1 X18
G1 Z5
G0 G40 G7 Z150
```

Second fixture:

Set new part zero

```
(MSG "*" NEW FIXTURE - REVERSE PART *")
M0 M5
(MSG "")
(ORGX54=0, ORGZ54=110)
G54
G92 S2200
```

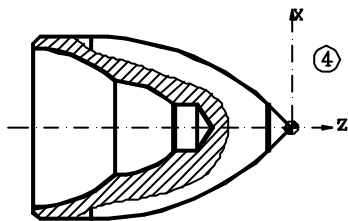

Operation 4 (Outside profile turning)

```
G95 G96 F0.2 S180 M4
T2 D2
G0 X85 Z20
G1 Z5
G68 X0 Z0 C1.5 L0.4 H0 S150 E160
G0 G42 X0 Z10
G1 G5 Z0 F0.1
N150 G1 X20 Z-10
N160 G3 X78 Z-85.2 I-83 K-75.2
G1 X80
G0 G40 G7 Z150
M30
```

Inside and outside taper threading.

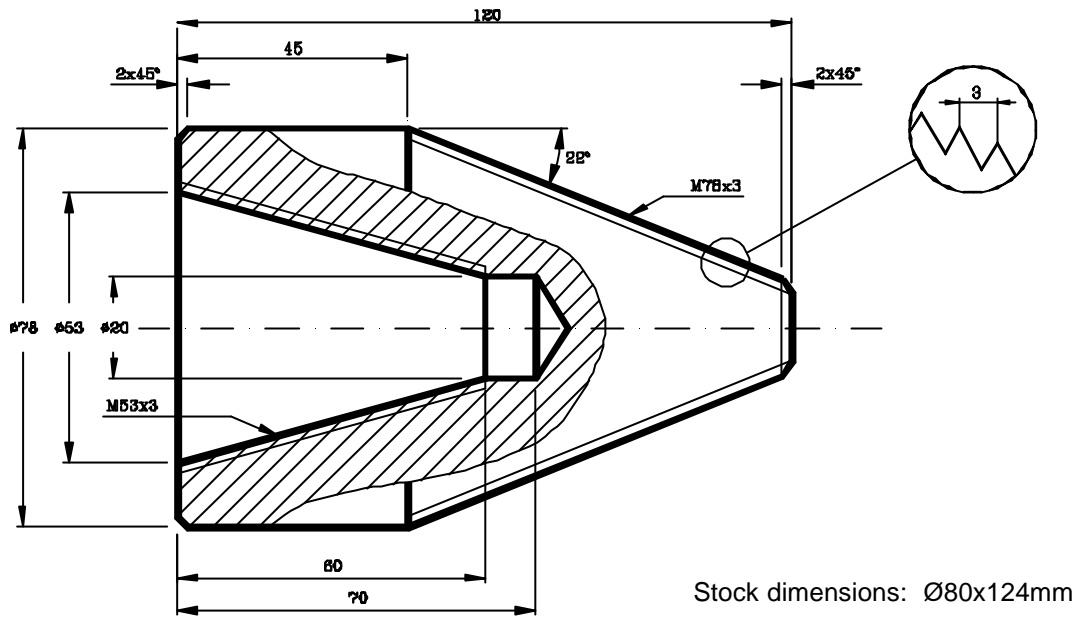

First fixture:

Set part zero

(ORGX54=0, ORGZ54=122)

G54

G92 S2200

Operation 1 (Drilling)

G95 G97 F0.15 S600 M4

G0 Z150

T9 D9

G0 X0 Z5

G83 X0 Z0 I75.773 B5 D5 K130 H0 C2

G0 Z150

Operation 2 (Facing and outside turning)

G95 G96 F0.2 S180 M4

T2 D2

G0 X78 Z5

G1 Z-50

X86

G0 G41 X79 Z-2.5

G1 X74 Z0

X16

G0 G40 Z150

Operation 3 (Inside taper turning)

G95 G96 F0.2 S120 M4

T8 D8

G0 X20 Z20

G1 G41 X16 Z1.5

G81 X53 Z0 Q20 R-60 C1.5 L0.3 M0.25 H0.1

G0 G40 Z150

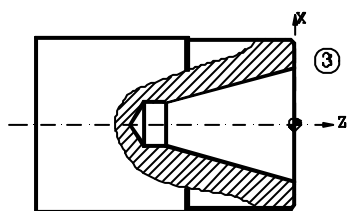
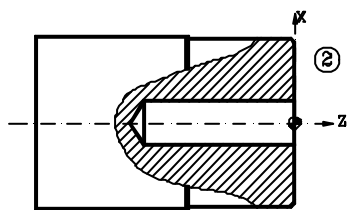
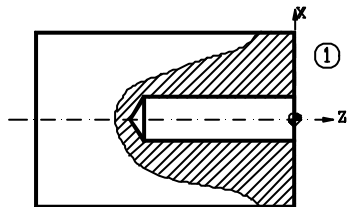

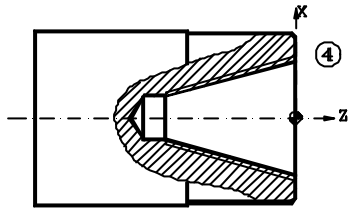

Operation 4 (Inside taper threading)

```
G95 G96 F0.15 S60 M4
T10 D10
G0 X20 Z20
G1 X16 Z1.5
G86 X53 Z0 Q20 R-60 I-1 B0.4 D-2 L0 C-3 J5 A29.5
G0 Z150
```

Second fixture:

Set new part zero

```
(MSG "** NEW FIXTURE - REVERSE PART **")
M0 M5
(MSG "")
(ORGX54=0, ORGZ54=120)
G54
G92 S2200
```

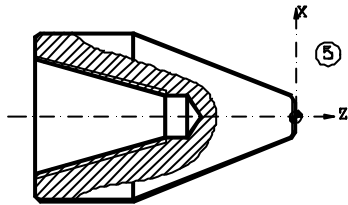

Operation 5 (Outside taper threading)

```
G95 G96 F0.2 S180 M4
T2 D2
G0 X90 Z20
G1 G42 X85 Z5
G81 X17.396 Z0 Q78 R-75 C2 L0.3 M0.3 H0.1
G0 G40 X20.396 Z0
G1 X-0.4
G1 Z5
G0 Z150
```

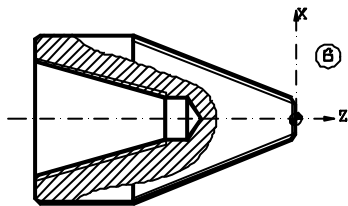

Operation 6 (Outside taper threading)

```
G95 G96 F0.15 S60 M4
T11 D11
G0 X80 Z1.5
G86 X17.396 Z0 Q78 R-75 I2 B.4 D-2 L0 C-3 J5 A29.5
G0 Z150
M30
```

Inside and outside roughing on X. Outside grooving and threading.

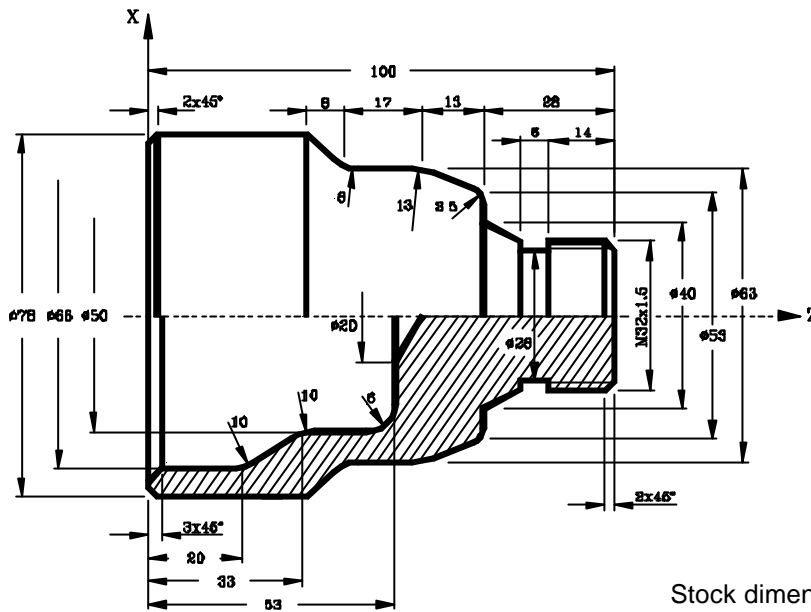

Stock dimensions: Ø80x104mm

First fixture:

Set part zero

(ORGX54=0, ORGZ54=102)

G54

G92 S2200

Operation 1 (Facing and outside turning)

G95 G96 F0.2 S180 M4

G0 Z150

T2 D2

G0 X90 Z20

G1 X78 Z5

Z-38

X82

G0 Z0

G1 X-0.4

G1 Z5

G0 G42 X72 Z1

G1 X80 Z-3

X85

G0 G40 X60 Z150

Operation 2 (Drilling)

G94 G97 F90 S600 M4

T9 D9

G0 X0 Z10

G83 X0 Z1 I58.773 B5 D2 K5 H0 C1

G0 Z150

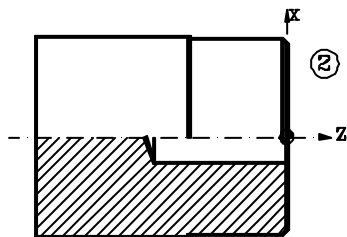
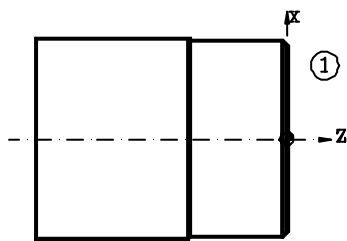

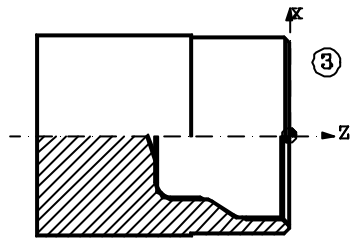

Operation 3 (Inside profile turning)

```
G95 G96 F0.1 S120 M4
T8 D8
G0 X18.2 Z10
G68 X74 Z1 C1 L0.3 H0 S100 E110
G0 G41 X74 Z1
N100 G1 G5 X66 Z-3
Z-17.169
G3 X63.033 Z-22.411 I-10 K0
G1 G36 R10 X50 Z-33
X50 Z-47
G3 X38 Z-53 I-6 K0
N110 G1 X19 Z-53
G0 G40 G7 Z150
```

Second fixture:

Set new part zero

```
(MSG "*" NEW FIXTURE - REVERSE PART *)
M0 M5
(MSG "")
(ORGX54=0, ORGZ54=100)
G54
G92 S2200
```

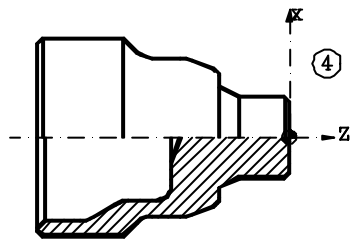

Operation 4 (Outside profile turning)

```
G95 G96 F0.2 S180 M4
T2 D2
G0 X90 Z20
G1 X82 Z0
G1 X-0.4
G1 Z5
G0 X82.5 Z4
G68 X27 Z0.5 C1 L0.3 H0 S120 E130
G1 G42 X27 Z0.5
N120 G1 G5 X32 Z-2
X32 Z-20
X40 Z-28
G36 R3.5 X53 Z-28
G36 R13 X63 Z-41
X63 Z-54.836
G2 X67.327 Z-60.308 I8 K0
G1 X78 Z-66
N130 X81 Z-67
G0 G40 X90 Z150
```

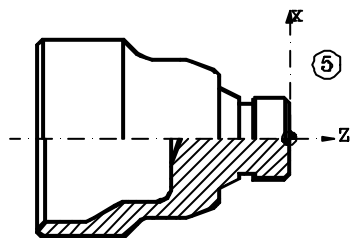

Operation 5 (Grooving)

```
G95 G96 F0.08 S50 M4
T12 D12
G0 G41 X34 Z-17
G88 X32 Z-20 Q28 R-14 D1 K2
G0 G40 X80 Z150
```

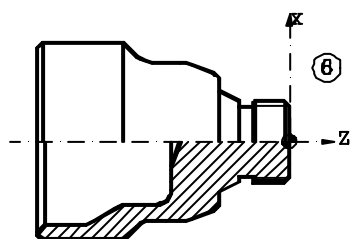

Operation 6 (Outside threading)

```
G95 G96 F0.15 S60 M4
T11 D11
G0 X35 Z5
G86 X32 Z3 Q32 R-16 I0.8 B0.1 D1 L0 C1.5 J0 A29.5
G0 X80 Z150
M30
```

Outside pattern repeat. Inside grooving and threading.

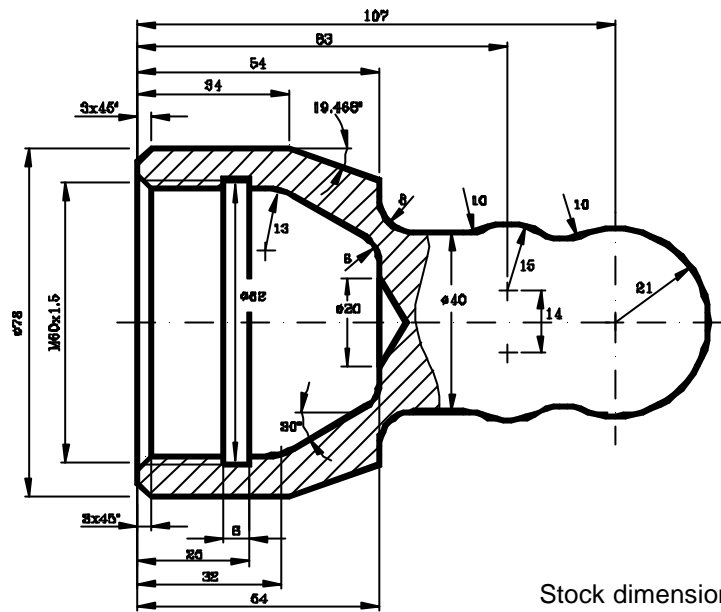

Stock dimensions: Ø80x132mm

First fixture:

Set part zero

(ORGX54=0, ORGZ54=130)

G54

G92 S2200

Operation 1 (Facing and outside turning)

G95 G96 F0.2 S180 M4

G0 Z150

T2 D2

G0 X90 Z20

G1 X78 Z5

G1 Z-36 F200

G1 X85

G0 Z0

G1 X-0.4

G1 Z5

G0 G42 X70 Z1

G1 X80 Z-4

G0 G40 X90 Z150

Operation 2 (Drilling)

G94 G97 F90 S600 M4

T9 D9

G0 X0 Z10

G83 X0 Z1 I59.773 B13 D2 K1 H0 C1

G0 Z150

Operation 3 (Inside profile)

G95 G96 F0.2 S120 M4

T8 D8

G0 X16 Z5

G68 X64.35 Z0 C1 L0.5 H0 S100 E110

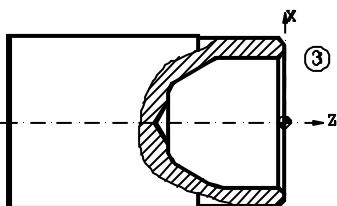
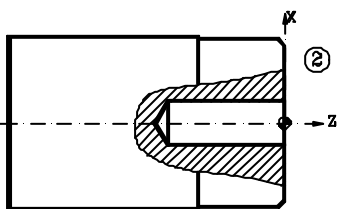
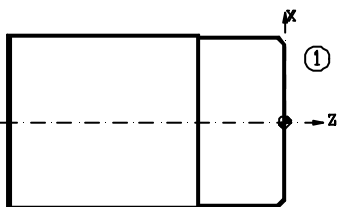

```
G0 G41 X65.35 Z0.5
N100 G1 G5 X58.35 Z-3
G1 G36 R13 X58.35 Z-32
G1 G36 R6 X25.4024 Z-54
N110 G1 X18 Z-54
G0 G40 G7 Z150
```

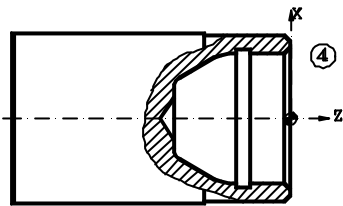

Operation 4 (Inside grooving)

```
G95 G96 F0.08 S50 M4
T13 D13
G0 G41 X40 Z-15
G88 X60 Z-19 Q62 R-25 K5
G0 Z150
```

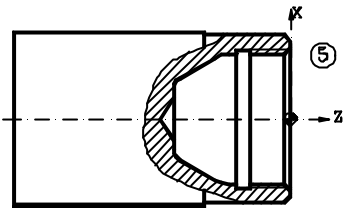

Operation 5 (Inside threading)

```
G95 G96 F0.15 S60 M4
T10 D10
G0 X40 Z1.5
G86 X60 Z0 Q60 R-20 I-0.8 B0.4 D-2 L0 C1.5 J0 A29.5
G0 Z150
```

Second fixture:

Set new part zero

```
(MSG "** NEW FIXTURE - REVERSE PART **")
M0 M5
(MSG "")
(ORGX54=0, ORGZ54=128)
G54
G92 S2200
```

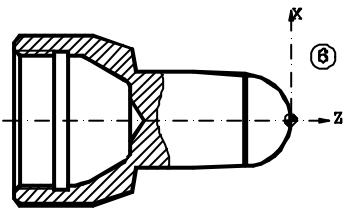

Operation 6 (Outside profile roughing)

```
G95 G96 F0.2 S120 M4
T2 D2
G0 X85 Z5
G68 X0 Z0 C1.5 L0.5 H0 S120 E130
(GOTO N140)
N120 G3 X42 Z-21 I0 K-21
G1 X44 Z-45
X44 Z-69.5
X66 Z-73
N130 X80 Z-94
N140 G0 Z20
```

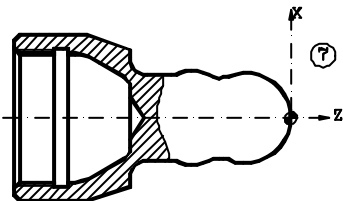

Operation 7 (Outside profile finishing)

```
G95 G96 F0.2 S120 M4
G0 G90 X85 Z20
G1 X85 Z5
G66 X0 Z0 I2.5 C0.5 L0.2 H0.1 S150 E160
(GOTO N170)
N150 G5 G3 G36 R10 X33.56 Z-33.63 R21
G3 G36 R10 X40 Z-52.48 R15
G1 G36 R8 X40 Z-74
X63.86 Z-74
N160 G7 X78 Z-94
N170 G90 G0 Z150
M30
```

Inside and outside roughing on the X axis

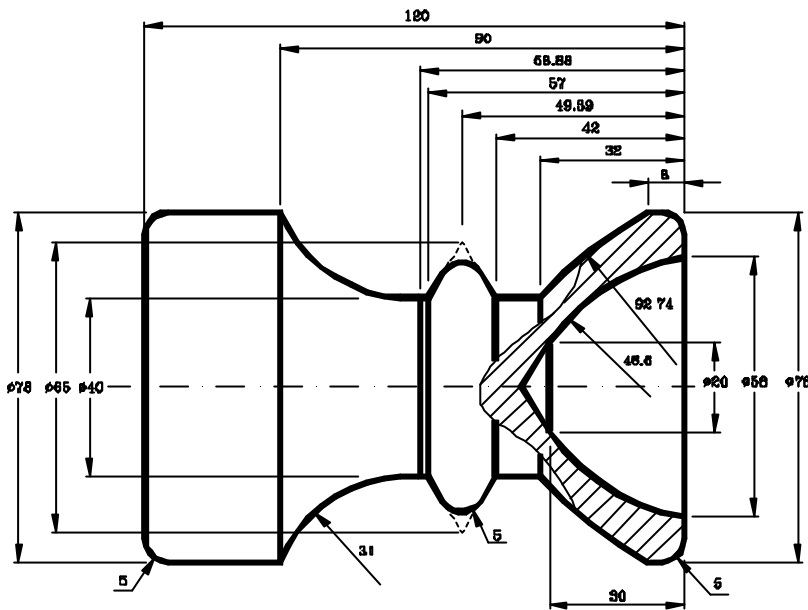

Stock dimensions: $\varnothing 80 \times 124 \text{ mm}$

First fixture:

Set part zero

(ORGX54=0, ORGZ54=122)

G54

G92 S2200

Operation 1 (Facing and outside turning)

G95 G96 F0.2 S180 M4

G0 Z150

T2 D2

G0 X90 Z20

G1 X85 Z0

X-0.4

Z5

G1 G42 X0 Z0

G36 R5 X78 Z0

Z-35

X85

G0 G40 X90 Z150

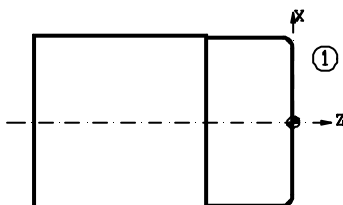

Second fixture:

Set new part zero

(MSG ``* NEW FIXTURE - REVERSE PART *``)

M0 M5

(MSG ````)

(ORGX54=0, ORGZ54=120)

G54

G92 S2200

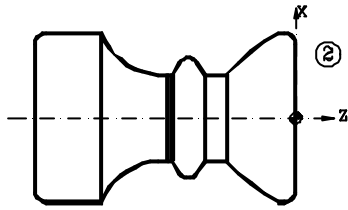

Operation 2 (Outside profile turning)

```
G95 G96 F0.2 S180 M4
T3 D3
G0 X80 Z20
G1 Z5
G68 X0 Z0 C1 L0.5 H0.1 S100 E110
(GOTO N120)
N100 G1 G36 R5 X78 Z0
Z-8
G3 X40 Z-32 R92.74
G1 Z-42
G36 R5 X65 Z-49.39
X40 Z-57
N110 G2 X78 Z-90 R31
N120 G0 Z150
```

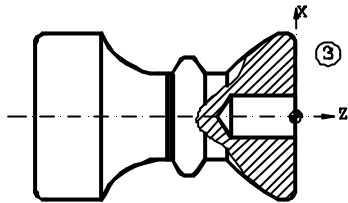

Operation 3 (Drilling)

```
G94 G97 F90 S600 T9 M4
G0 X0 Z10
G83 X0 Z0 I35.773 B10 D2 H5 C2
G0 Z150
```

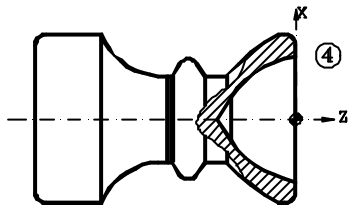

Operation 4 (Inside profile turning)

```
G95 G96 F0.1 S120 M4
T8 D8
G0 X16 Z20
G1 Z5
G68 X58 Z0 C1 L0.5 H0.1 S150 E160
(GOTO N170)
N150 G3 X20 Z-30 R46.6
N160 G1 X19
N170 G1 Z20
G0 X85 Z150
M30
```

User Notes:



8040T 8055T

Machining a profile in the ZC plane.	34
Machining a profile in the XC plane.	35



**Programming examples:
«C» axis programming**

Machining a profile in the ZC plane.

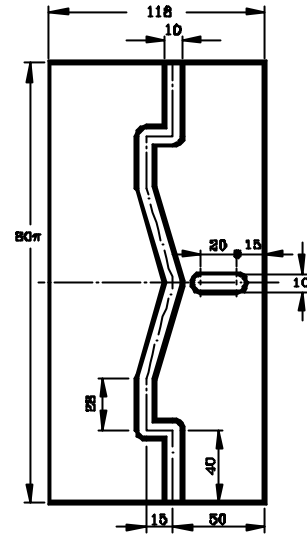
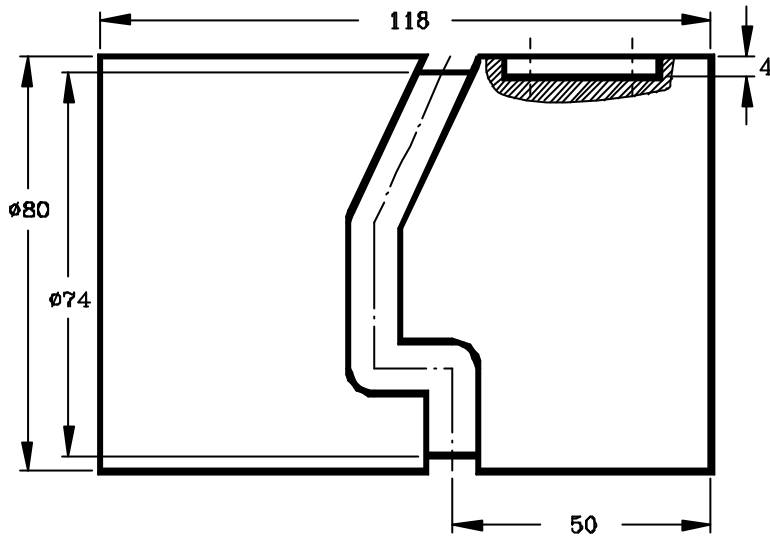

Selecting the radial live tool.

```
G0 X100 Z150
T15 D15
M45 S-600
```

Operation 1 (Machining of the slot)

```
G15 R36 ..... Select the "C" axis.
G16 ZC ..... Select the work plane.
G0 X90
Z-15 C0
G1 G94 X72 F100 M13
Z-35
G1 X90
```

Operation 2 (Grooving)

```
G15 R37
G16 ZC
G0 Z-50 C-125.664 ..... Position at point A.
G1 X74 F100
G91 C40 F50 ..... Section A-B.
Z-15 ..... Section B-C.
C28 ..... Section C-D.
Z15 C57.664 ..... Section D-E.
Z-15 C57.664 ..... Section E-F.
C28 ..... Section F-G.
Z15 ..... Section G-H.
C40 ..... Section H-A.
G90 X90
G0 Z10
M30
```

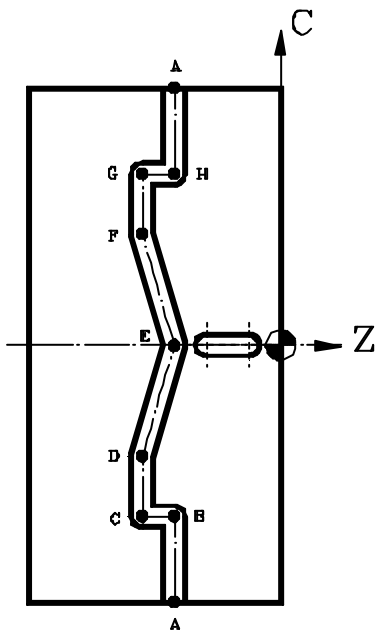

Machining a profile in the XC plane.

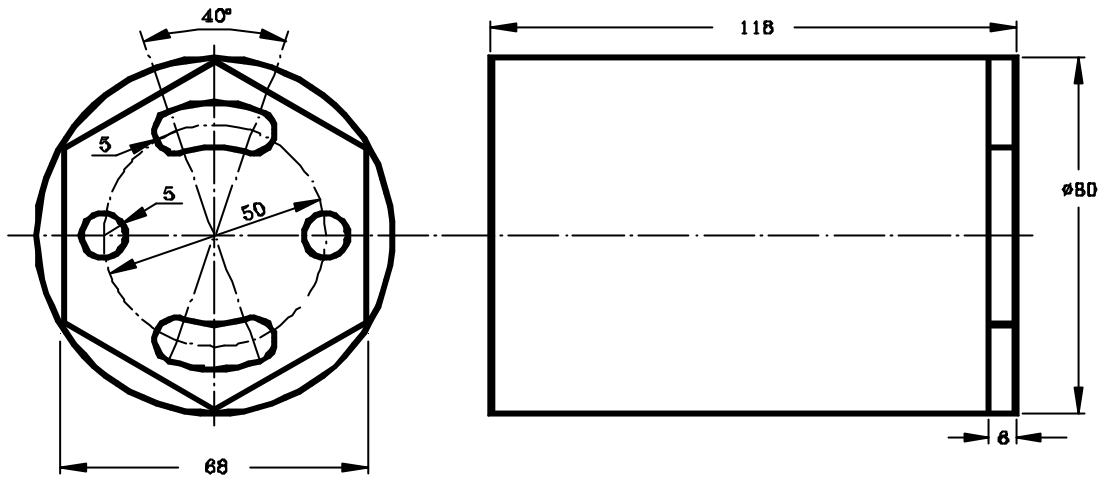

Select the axial live tool.

G0 X100 Z150
T16 D16
M45 S600

Operation 1 (Machining of a hexagon)

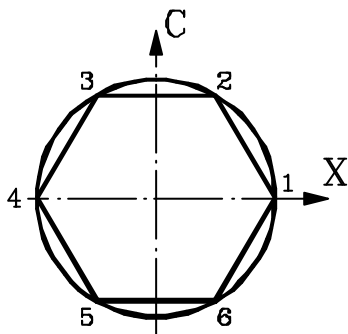

G15 Select the "C" axis.
G16 XC Select the work plane.
G94 Z10 C0 F100
G1 Z-6
G1 G42 X39.26 C0 Position at point 1.
X19.63 C34 Section 1-2.
X-19.63 C34 Section 2-3.
X-39.26 C0 Section 3-4.
X-19.36 C-34 Section 4-5.
X19.63 C-34 Section 5-6.
X39.26 C0 Section 6-1.
G0 G40 X50
Z10

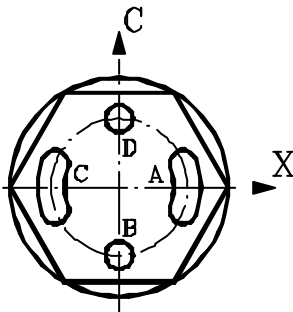

Operation 2 (Making the grooves and the holes)

X23.492 C8.55
G1 Z-5 F50
G2 X23.492 C-8.55 R25 Grooving A.
G0 Z5
X0 C-25 Position at point B.
G1 Z-5
G1 Z5
G0 X-23.492 C-8.55
G1 Z-5
G2 X-23.492 C8.55 R25 Grooving C.
G0 Z5
X0 C25 Position at point D.
G1 Z-5
G0 Z5
M30

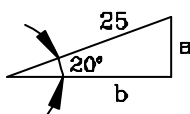

$$a = 25 \sin 20^\circ$$

$$b = 25 \cos 20^\circ$$

User Notes:



8040T

8055T

Profile editor. Example 1.	38
Profile editor. Example 2.	39
Profile editor. Example 3.	40
Profile editor. Example 4.	41

Programming examples: Profile Editor

Profile editor. Example 1.

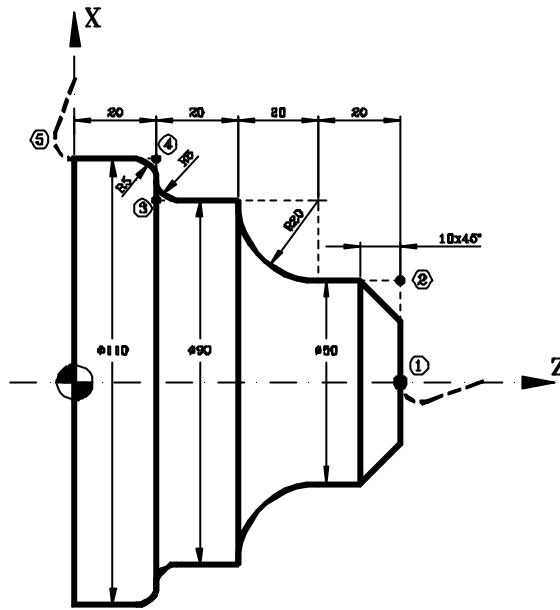

PROFILE DEFINITION WITHOUT ROUNDINGS, CHAMFERS, TANGENTIAL ENTRY AND EXIT

- STARTING POINT : Z = 100 X = 0
- STRAIGHT : Z = 80 X = 0
- STRAIGHT : Z = 80 X = 50
- STRAIGHT : Z = 60 X = 50
- CLOCKWISE ARC : Z = 40 X = 90 Radius = 20
- STRAIGHT : Z = 20 X = 90
- STRAIGHT : Z = 20 X = 110
- STRAIGHT : Z = 0 X = 110
- STRAIGHT : Z = 0 X = 150

DEFINITION OF ROUNDINGS, CHAMFER TANGENTIAL ENTRY AND EXIT

Select the «MODIFY» option and define:

- TANGENTIAL ENTRY Select point "1" Press ENTER Enter Radius = 5
- CHAMFER..... Select point "2" Press ENTER Enter Size = 10
- ROUNDING Select point "3" Press ENTER Enter Radius = 5
- ROUNDING Select point "4" Press ENTER Enter Radius = 5
- TANGENTIAL EXIT Select point "5" Press ENTER Enter Radius = 5

Press ESC to quit the «Modify» option.

END OF EDITING

Select the softkeys: END + SAVE PROFILE. The CNC quits the profile editing mode and shows, in ISO code, the program that has been generated.

Profile editor. Example 2.

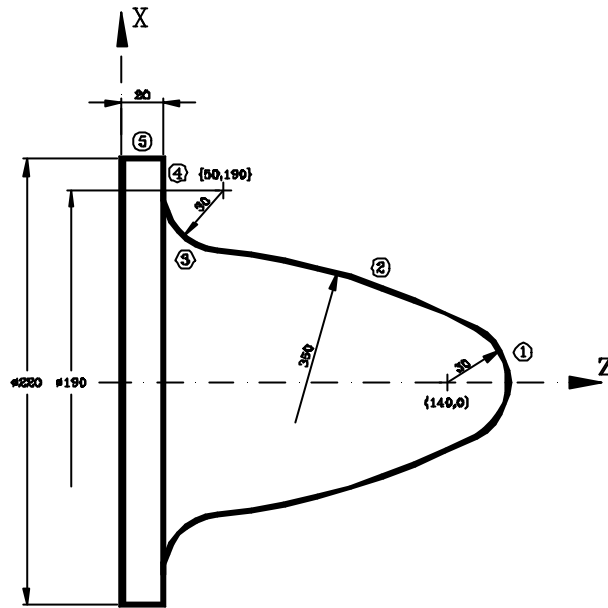

PROFILE DEFINITION

- STARTING POINT : Z= 170 X= 0
- CCW ARC (1) : Zcenter= 140 Xcenter= 0 Radius= 30 Tangent= Yes
- CCW ARC (2) : Radius= 350 Tangent= Yes
- CW ARC (3) : Zcenter= 50 Xcenter= 190 Radius= 30 Tangent= Yes
The CNC shows all the possible options for section 2. Select the right one
- STRAIGHT LINE (4) : Z = 20 X = 220 Tangent= Yes
The CNC shows all the possible options for sections 3-4. Select the right one
- STRAIGHT LINE (5) : Z = 0 X= 220

END OF EDITING

Select the softkeys: END + SAVE PROFILE. The CNC quits the profile editing mode and shows, in ISO code, the program that has been generated.

Profile editor. Example 3.

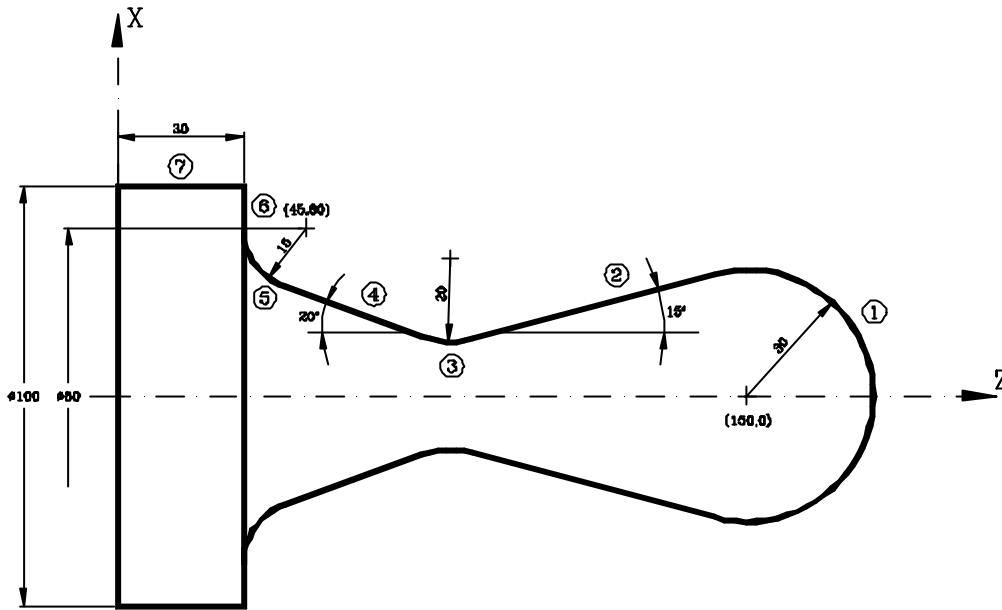

PROFILE DEFINITION

- STARTING POINT : Z = 180 X = 0
- CCW ARC (1) : Zcenter= 150 Xcenter=0 Radius = 30
- STRAIGHT LINE (2) : Angle= 195 Tangent = Yes
The CNC shows all the possible options between sections 1-2. Select the right one
- CW ARC (3) : Radius = 20 Tangent = Yes
- STRAIGHT LINE (4) : Angle= 160 Tangent = Yes
- CW ARC (5) : Z = 30 X = 80 Zcenter= 45 Xcenter= 80 Tangent= Yes
The CNC shows all the possible options between sections 4-5. Select the right one
The CNC shows all the possible options for section 3. Select the right one
- STRAIGHT LINE (6) : Z = 30 X = 100
- STRAIGHT LINE (7) : Z = 0 X = 100

END OF EDITING

Select the softkeys END + SAVE PROFILE. The CNC quits the profile editing mode and shows, in ISO code, the program that has been generated.

Profile editor. Example 4.

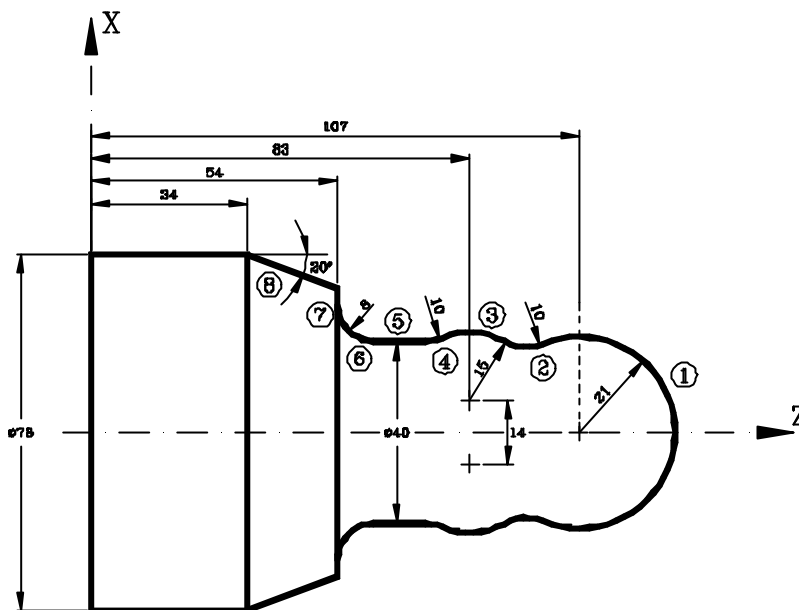

PROFILE DEFINITION

- STARTING POINT : Z = 128 X = 0
- CCW ARC (1) : Zcenter = 107 Xcenter = 0 Radius = 21
- CW ARC (2) : Radius= 10 Tangent = Yes
- CCW ARC (3) : Zcenter = 83 Xcenter = 14 Radius = 15 Tangent = Yes
The CNC shows all the possible options for section 2. Select the right one.
- CW ARC (4) : Radius= 10 Tangent = Yes
- STRAIGHT LINE (5) : X = 40 Angle= 180 Tangent = Yes
The CNC shows all the possible options for section 4. Select the right one.
- CW ARC (6) : Z = 54 X = 56 Radius = 8 <Tangent = Yes
- STRAIGHT LINE (7) : Z = 54 Angle=90 Tangent = Yes
- STRAIGHT LINE (8) : Z = 34 X = 78 Angle=160

END OF EDITING

Select the softkeys END + SAVE PROFILE. The CNC quits the profile editing mode and shows, in ISO code, the program that has been generated.

User Notes:



8040T 8055T

Machine diagnosis.	44
Machining a pulley.	52



**Programming examples:
User screen customizing programs**

Machine diagnosis.

This example shows:

a.- How to write a user screen customizing program.

In order to be able to execute this program in the user channel of the MANUAL mode, general machine parameter «USERMAN» must be set with the program number.

For better understanding, the explanation is divided into parts indicating the section of the program and the creation of the corresponding screens (pages) and symbols. The different parts are:

- Part 1 : It requests the access code (password).
- Part 2 : It shows the status of inputs I1 to I40.
(it uses user page 2 and the symbols 21 and 22)
- Part 3 : It shows the status of outputs O1 to O18.
(It uses user page 3 and the symbols 21 and 22)
- Part 4 : It shows the consumption of the motors.
(It uses user page 4 and the symbols 0 to 20)

To go to the previous or next page, use the «previous page» and «next page» keys.

b.- How to create a user screen (page).

c.- How to create a user symbol.

Part 1: "Request password"

```

N100 (IB1= INPUT "PASSWORD = ", 6) ..... Requests the password
      (IF IB1 NE (123456) GOTO N100) ..... If the password is not correct (123456), it requests
                                             it again.

;
N200 ..... If it is correct, the program continues on line
                                             N200 (part 2)

```

Part 2: "Shows the status of inputs I1 through I40"

Program lines (main program).

```

N200 (PAGE2) ..... Shows page 2
      (KEY=0) ..... Clears the memory of the last key pressed.
N210 (P100=PLCI1) ..... Assigns to parameter P100, the value of inputs I1 to I32
      (P199=85) ..... Row where to insert the symbol
      (CALL 2) ..... Call to subroutine (it inserts symbols)
      (P100=PLCI11) ..... Assigns to parameter P100 the value of inputs I11 to I42
      (P199=155) ..... Row where to insert the symbol
      (CALL 2) ..... Call to subroutine (it inserts symbols)
      (P100=PLCI21) ..... Assigns to parameter P100 the value of inputs I21 to I52
      (P199=225) ..... Row where to insert the symbol
      (CALL 2) ..... Row where to insert the symbol
      (P100=PLCI31) ..... Asigna al parámetro P100 el valor de las entradas I31 a I62
      (P199=295) ..... Row where to insert the symbol
      (CALL 2) ..... Row where to insert the symbol
      (IF KEY EQ $FFAF GOTO N300) ... If "next page" has been pressed, it goes on to line N300 (part 3)
      (GOTO N210) ..... If not, refresh the status of the inputs.
  
```

Program lines (subroutine that indicates the status of a row of inputs).

This subroutine analyzes the 10 least significant bits of parameter P100. If the bit is set to «1», it inserts symbol 21 (lamp lit, red color) and if it is set to «0», it inserts symbol 22 (lamp off, background color).

Call parameters:

- P100 = Value of the inputs to be displayed.
- P199 = Row where the symbols are to be inserted.

```

(SUB 2)
  (IF (P100 AND 1) EQ 0 SYMBOL 22,80,P199 ELSE SYMBOL 21,80,P199)
  (IF (P100 AND 2) EQ 0 SYMBOL 22,130,P199 ELSE SYMBOL 21,130,P199)
  (IF (P100 AND 4) EQ 0 SYMBOL 22,180,P199 ELSE SYMBOL 21,180,P199)
  (IF (P100 AND 8) EQ 0 SYMBOL 22,230,P199 ELSE SYMBOL 21,230,P199)
  (IF (P100 AND $10) EQ 0 SYMBOL 22,280,P199 ELSE SYMBOL 21,280,P199)
  (IF (P100 AND $20) EQ 0 SYMBOL 22,330,P199 ELSE SYMBOL 21,330,P199)
  (IF (P100 AND $40) EQ 0 SYMBOL 22,380,P199 ELSE SYMBOL 21,380,P199)
  (IF (P100 AND $80) EQ 0 SYMBOL 22,430,P199 ELSE SYMBOL 21,430,P199)
  (IF (P100 AND $100) EQ 0 SYMBOL 22,480,P199 ELSE SYMBOL 21,480,P199)
  (IF (P100 AND $200) EQ 0 SYMBOL 22,530,P199 ELSE SYMBOL 21,530,P199)
(RET)
  
```

Editing symbols 21 and 22.

Access the screen customizing mode and select: [Utilities] [Editor] [Symbol] (symbol number) [Enter]

Symbol 21

Background color: Navy blue
 Main color: Red
 Line: Fine solid
 Filled circle
 Center: X10 Y10
 Move to.: X10 Y15

Symbol 22

Background color: Navy blue
 Main color: Navy blue
 Line: Fine solid
 Filled circle
 Center: X10 Y10
 Move to.: X10 Y15

Editing page 2

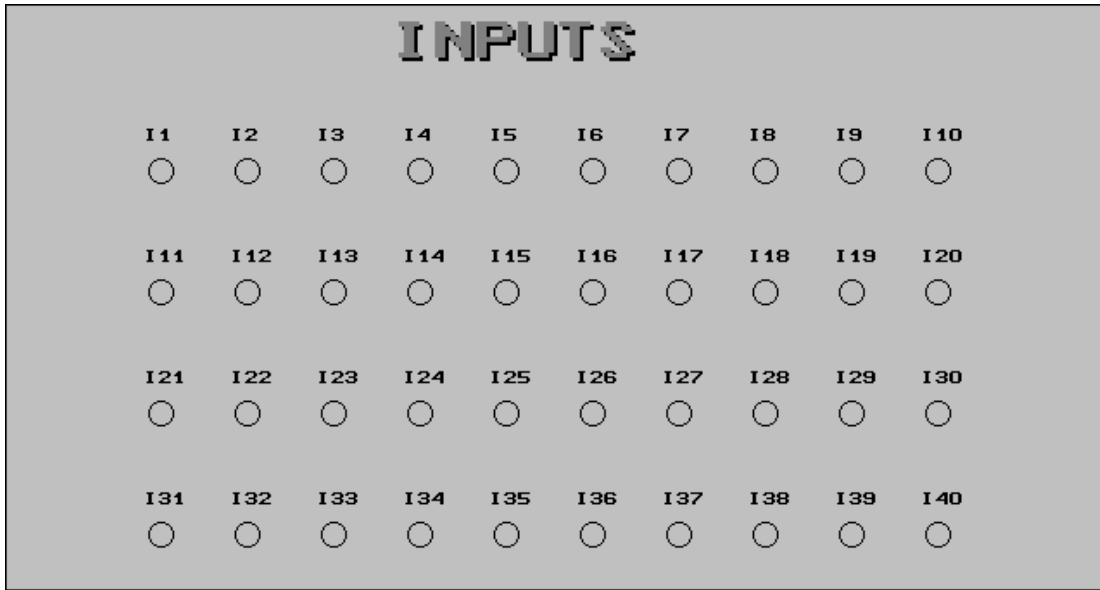

Access the screen customizing mode and select: [Utilities] [Edit] [Page] 2 [Enter]

Select background color: Navy blue

Edit the following texts:

Main color	Size	Text	Position
White	Large	INPUTS	X226 Y10
Red	Large	INPUTS	X224 Y8
White	Small	I1	X80 Y70
White	Small	I2	X130 Y70
White	Small	I3	X180 Y70
White	Small	I4	X230 Y70
White	Small	I5	X280 Y70
White	Small	I6	X330 Y70
White	Small	I7	X380 Y70
White	Small	I8	X430 Y70
White	Small	I9	X480 Y70
White	Small	I10	X530 Y70
White	Small	I11	X80 Y140
White	Small	I12	X130 Y140

Main color	Size	Text	Position
White	Small	I13	X180 Y140
White	Small	I14	X230 Y140
White	Small	I15	X280 Y140
White	Small	I16	X330 Y140
White	Small	I17	X380 Y140
White	Small	I18	X430 Y140
White	Small	I19	X480 Y140
White	Small	I20	X530 Y140
White	Small	I21	X80 Y210
White	Small	I22	X130 Y210
White	Small	I23	X180 Y210
White	Small	I24	X230 Y210
White	Small	I25	X280 Y210
White	Small	I26	X330 Y210

Main color	Size	Text	Position
White	Small	I27	X380 Y210
White	Small	I28	X430 Y210
White	Small	I29	X480 Y210
White	Small	I30	X530 Y210
White	Small	I31	X80 Y280
White	Small	I32	X130 Y280
White	Small	I33	X180 Y280
White	Small	I34	X230 Y280
White	Small	I35	X280 Y280
White	Small	I36	X330 Y280
White	Small	I37	X380 Y280
White	Small	I38	X430 Y280
White	Small	I39	X480 Y280
White	Small	I40	X530 Y280

Edit the following circles (unfilled) with white main color and line type: Fine solid.

Main color	Center	Move to...
White	X90 Y95	X90 Y102
White	X140 Y95	X140 Y102
White	X190 Y95	X190 Y102
White	X240 Y95	X240 Y102
White	X290 Y95	X290 Y102
White	X340 Y95	X340 Y102
White	X390 Y95	X390 Y102
White	X440 Y95	X440 Y102
White	X490 Y95	X490 Y102
White	X540 Y95	X540 Y102
White	X90 Y165	X90 Y172
White	X140 Y165	X140 Y172
White	X190 Y165	X190 Y172
White	X240 Y165	X240 Y172

Main color	Center	Move to...
White	X290 Y165	X290 Y172
White	X340 Y165	X340 Y172
White	X390 Y165	X390 Y172
White	X440 Y165	X440 Y172
White	X490 Y165	X490 Y172
White	X540 Y165	X540 Y172
White	X90 Y235	X90 Y242
White	X140 Y235	X140 Y242
White	X190 Y235	X190 Y242
White	X240 Y235	X240 Y242
White	X290 Y235	X290 Y242
White	X340 Y235	X340 Y242
White	X390 Y235	X390 Y242
White	X440 Y235	X440 Y242

Main color	Center	Move to...
White	X490 Y235	X490 Y242
White	X540 Y235	X540 Y242
White	X90 Y305	X90 Y312
White	X140 Y305	X140 Y312
White	X190 Y305	X190 Y312
White	X240 Y305	X240 Y312
White	X290 Y305	X290 Y312
White	X340 Y305	X340 Y312
White	X390 Y305	X390 Y312
White	X440 Y305	X440 Y312
White	X490 Y305	X490 Y312
White	X540 Y305	X540 Y312



Part 3: "Shows the status of outputs O1 to O18"

Program lines (main program).

```

N300 (PAGE3) ..... Shows page 3
      (KEY = 0 ) ..... Clears memory of last key pressed
N310 (P100=PLCO1) ..... Assigns to parameter P100 the value of the outputs O1 to O32
      (P199=85) ..... Row where to insert the symbol
      (CALL 3) ..... Call to subroutine (it inserts symbols)
      (P100=PLCO10) ..... Assigns to parameter P100 the value of the outputs O10 to O41
      (P199=155) ..... Row where to insert the symbol
      (CALL 3) ..... Call to subroutine (it inserts symbols)
      (IF KEY EQ $FFA5 GOTO N200) ... If "previous page" has been pressed, it goes on to line N200
                                      (part 2)
      (IF KEY EQ $FFAF GOTO N400) ... If "next page" has been pressed, it goes on to line N400
                                      (part 4)
      (GOTO N310) ..... If not, it refreshes the status of the outputs

```

Program lines (subroutine that indicates the status of a row of outputs).

This subroutine analyzes the 10 least significant bits of parameter P100. If the bit is set to «1», it inserts symbol 21 (lamp on, red color), if it is set to «0», it inserts symbol 22 (lamp off, background color).

Call parameters:

- P100 = Value of the outputs to be displayed.
- P199 = Row where to insert the symbols.

```

(SUB 3)
  (IF (P100 AND 1) EQ 0 SYMBOL 22,105,P199 ELSE SYMBOL 21,105,P199)
  (IF (P100 AND 2) EQ 0 SYMBOL 22,155,P199 ELSE SYMBOL 21,155,P199)
  (IF (P100 AND 4) EQ 0 SYMBOL 22,205,P199 ELSE SYMBOL 21,205,P199)
  (IF (P100 AND 8) EQ 0 SYMBOL 22,255,P199 ELSE SYMBOL 21,255,P199)
  (IF (P100 AND $10) EQ 0 SYMBOL 22,305,P199 ELSE SYMBOL 21,305,P199)
  (IF (P100 AND $20) EQ 0 SYMBOL 22,355,P199 ELSE SYMBOL 21,355,P199)
  (IF (P100 AND $40) EQ 0 SYMBOL 22,405,P199 ELSE SYMBOL 21,405,P199)
  (IF (P100 AND $80) EQ 0 SYMBOL 22,455,P199 ELSE SYMBOL 21,455,P199)
  (IF (P100 AND $100) EQ 0 SYMBOL 22,505,P199 ELSE SYMBOL 21,505,P199)
(RET)

```

Editing page 3

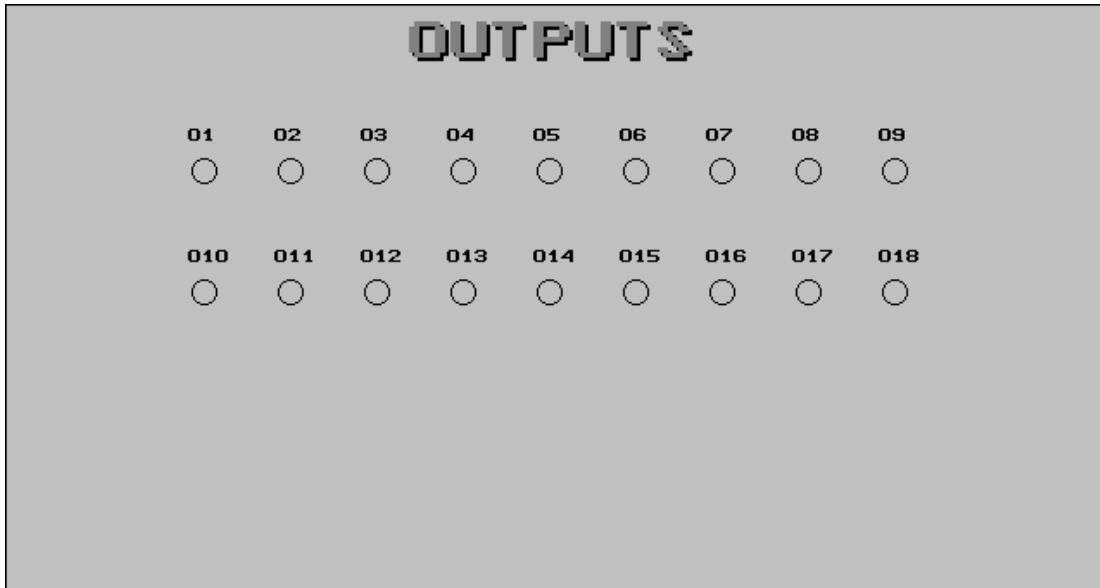

Access the screen customizing mode and select: [Utilities] [Editor] [Page] 3 [Enter]

Select background color: Navy blue

Edit the following texts:

Main color	Size	Text	Position
White	Large	OUTPUTS	X235 Y10
Red	Large	OUTPUTS	X233 Y8
White	Small	O1	X105 Y70
White	Small	O2	X155 Y70
White	Small	O3	X205 Y70
White	Small	O4	X255 Y70
White	Small	O5	X305 Y70

Main color	Size	Text	Position
White	Small	O6	X355 Y70
White	Small	O7	X405 Y70
White	Small	O8	X455 Y70
White	Small	O9	X505 Y70
White	Small	O10	X105 Y140
White	Small	O11	X155 Y140
White	Small	O12	X205 Y140

Main color	Size	Text	Position
White	Small	O13	X255 Y140
White	Small	O14	X305 Y140
White	Small	O15	X355 Y140
White	Small	O16	X405 Y140
White	Small	O17	X455 Y140
White	Small	O18	X505 Y140

Edit the following circles (unfilled) with white main color and line type: Fine solid.

Main color	Center	Move to...
White	X115 Y95	X115 Y102
White	X165 Y95	X165 Y102
White	X215 Y95	X215 Y102
White	X265 Y95	X265 Y102
White	X315 Y95	X315 Y102
White	X365 Y95	X365 Y102

Main color	Center	Move to...
White	X415 Y95	X415 Y102
White	X465 Y95	X465 Y102
White	X515 Y95	X515 Y102
White	X115 Y165	X115 Y172
White	X165 Y165	X165 Y172
White	X215 Y165	X215 Y172

Main color	Center	Move to...
White	X265 Y165	X265 Y172
White	X315 Y165	X315 Y172
White	X365 Y165	X365 Y172
White	X415 Y165	X415 Y172
White	X465 Y165	X465 Y172
White	X515 Y165	X515 Y172

Part 4: "Shows the consumption of motors"

The speed drives have an analog output (0 to 10V) proportional to the current consumed by the motor.

In this example, the following connections have been made:

- The X axis drive's current output is connected to the analog input 1 of the CNC.
- The Z axis drive's current output is connected to the analog input 2 of the CNC.
- The spindle (S) drive's current output is connected to the analog input 3 of the CNC.

Therefore, variables "ANAI1", "ANAI2" and "ANAI3" show the analog voltage corresponding to the currents of the X and Z axes and of the spindle S.

21 symbols (0-20) are used to display the value of the current, in increments corresponding to 0.5V.

To select the right symbol each time, the formula: "ABS ROUND (ANAI1/0.5)" is applied. In other words, the rounded-up absolute value of the result of the operation "ANAI1/0.5".

Program lines.

```

N400 (PAGE 4) ..... Shows page 4.
      (KEY = 0) ..... Clears memory of last key pressed.
N410 (SYMBOL ABS ROUND (ANAI1/0.5), 130, 120)
      (SYMBOL ABS ROUND (ANAI2/0.5), 130, 190)
      (SYMBOL ABS ROUND (ANAI3/0.5), 130, 260)
      (IF KEY EQ $FFA5 GOTO N300) ... If "previous page" has been pressed, it goes on to line N300
                                      (part 3)
      (GOTO N410) ..... If not, it refreshes the motor consumption.
    
```

Editing symbols 0-20

Access the screen customizing mode and select: [Utilities] [Editor] [Symbol] (symbol number) [Enter]

SYMBOL	FILLED RECTANGLE								FINE SOLID LINE						
	Green		Yellow		Red		Gray		Green		Yellow		Red		
	From	to	From	to	From	to	From	to	From	to	From	to	From	to	
0	---	---	---	---	---	---	---	X0 Y0	X400 Y30	X100 Y0	X100 Y30	X200 Y0	X200 Y30	X300 Y0	X300 Y30
1	X0 Y0	X20 Y30	---	---	---	---	---	X20 Y0	X400 Y30	X100 Y0	X100 Y30	X200 Y0	X200 Y30	X300 Y0	X300 Y30
2	X0 Y0	X40 Y30	---	---	---	---	---	X40 Y0	X400 Y30	X100 Y0	X100 Y30	X200 Y0	X200 Y30	X300 Y0	X300 Y30
3	X0 Y0	X60 Y30	---	---	---	---	---	X60 Y0	X400 Y30	X100 Y0	X100 Y30	X200 Y0	X200 Y30	X300 Y0	X300 Y30
4	X0 Y0	X80 Y30	---	---	---	---	---	X80 Y0	X400 Y30	X100 Y0	X100 Y30	X200 Y0	X200 Y30	X300 Y0	X300 Y30
5	X0 Y0	X100 Y30	---	---	---	---	---	X100 Y0	X400 Y30	---	---	X200 Y0	X200 Y30	X300 Y0	X300 Y30
6	X0 Y0	X120 Y30	---	---	---	---	---	X120 Y0	X400 Y30	---	---	X200 Y0	X200 Y30	X300 Y0	X300 Y30
7	X0 Y0	X140 Y30	---	---	---	---	---	X140 Y0	X400 Y30	---	---	X200 Y0	X200 Y30	X300 Y0	X300 Y30
8	X0 Y0	X160 Y30	---	---	---	---	---	X160 Y0	X400 Y30	---	---	X200 Y0	X200 Y30	X300 Y0	X300 Y30
9	X0 Y0	X180 Y30	---	---	---	---	---	X180 Y0	X400 Y30	---	---	X200 Y0	X200 Y30	X300 Y0	X300 Y30
10	X0 Y0	X200 Y30	---	---	---	---	---	X200 Y0	X400 Y30	---	---	---	---	X300 Y0	X300 Y30
11	X0 Y0	X200 Y30	X200 Y0	X220 Y30	---	---	---	X220 Y0	X400 Y30	---	---	---	---	X300 Y0	X300 Y30
12	X0 Y0	X200 Y30	X200 Y0	X240 Y30	---	---	---	X240 Y0	X400 Y30	---	---	---	---	X300 Y0	X300 Y30
13	X0 Y0	X200 Y30	X200 Y0	X260 Y30	---	---	---	X260 Y0	X400 Y30	---	---	---	---	X300 Y0	X300 Y30
14	X0 Y0	X200 Y30	X200 Y0	X280 Y30	---	---	---	X280 Y0	X400 Y30	---	---	---	---	X300 Y0	X300 Y30
15	X0 Y0	X200 Y30	X200 Y0	X300 Y30	---	---	---	X300 Y0	X400 Y30	---	---	---	---	---	---
16	X0 Y0	X200 Y30	X200 Y0	X300 Y30	X300 Y0	X320 Y30	X320 Y0	X400 Y30	---	---	---	---	---	---	---
17	X0 Y0	X200 Y30	X200 Y0	X300 Y30	X300 Y0	X340 Y30	X340 Y0	X400 Y30	---	---	---	---	---	---	---
18	X0 Y0	X200 Y30	X200 Y0	X300 Y30	X300 Y0	X360 Y30	X360 Y0	X400 Y30	---	---	---	---	---	---	---
19	X0 Y0	X200 Y30	X200 Y0	X300 Y30	X300 Y0	X380 Y30	X380 Y0	X400 Y30	---	---	---	---	---	---	---
20	X0 Y0	X200 Y30	X200 Y0	X300 Y30	X300 Y0	X400 Y30	---	---	---	---	---	---	---	---	---

Editing page 4

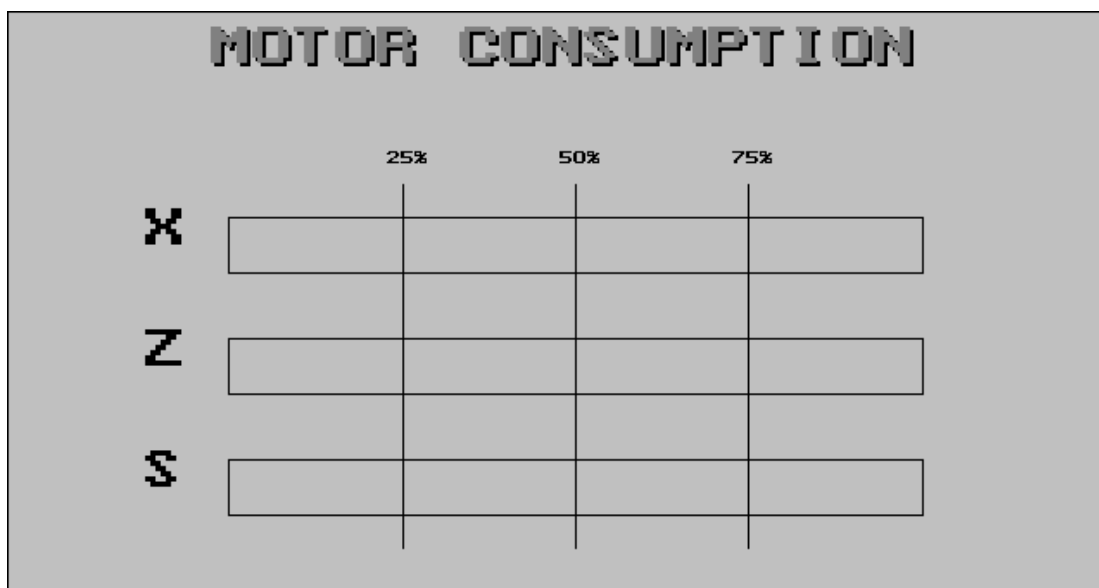

Access the screen customizing mode and select: [Utilities] [Editor] [Page] 4 [Enter]

Select background color: Navy blue

Edit the following texts:

Main color	Size	Text	Position
White	Large	MOTOR CONSUMPTION	X120 Y10
Red	Large	MOTOR CONSUMPTION	X118 Y8
White	Large	X	X80 Y113
White	Large	Z	X80 Y183

Main color	Size	Text	Position
White	Large	S	X80 Y253
White	Small	25%	X220 Y80
White	Small	50%	X320 Y80
White	Small	75%	X420 Y80

Edit the following graphics elements with line type: Fine solid.

Main color	Element	1st corner	2nd corner
White	Unfilled Rectangle	X129 Y119	X531 Y151
White	Unfilled Rectangle	X129 Y189	X531 Y221
White	Unfilled Rectangle	X129 Y259	X531 Y291

Main color	Element	1st end	2nd end
Green	Continuous line	X230 Y100	X230 Y310
Yellow	Continuous line	X330 Y100	X330 Y310
Red	Continuous line	X430 Y100	X430 Y310



Whole program

```

;Part 1 (password)
N100 (IB1=INPUT "PASSWORD = ", 6)
      (IF IB1 NE (123456) GOTO N100)
;
;Part 2 (status of the inputs)
N200 (PAGE2)
      (KEY = 0)
N210 (P100=PLC11)
      (P199=85)
      (CALL 2)
      (P100=PLC111)
      (P199=155)
      (CALL 2)
      (P100=PLC121)
      (P199=225)
      (CALL 2)
      (P100=PLC131)
      (P199=295)
      (CALL 2)
      (IF KEY EQ $FFAF GOTO N300)
      (GOTO N210)
;
      (SUB 2)
      (IF (P100 AND 1) EQ 0 SYMBOL 22,80,P199 ELSE SYMBOL 21,80,P199)
      (IF (P100 AND 2) EQ 0 SYMBOL 22,130,P199 ELSE SYMBOL 21,130,P199)
      (IF (P100 AND 4) EQ 0 SYMBOL 22,180,P199 ELSE SYMBOL 21,180,P199)
      (IF (P100 AND 8) EQ 0 SYMBOL 22,230,P199 ELSE SYMBOL 21,230,P199)
      (IF (P100 AND $10) EQ 0 SYMBOL 22,280,P199 ELSE SYMBOL 21,280,P199)
      (IF (P100 AND $20) EQ 0 SYMBOL 22,330,P199 ELSE SYMBOL 21,330,P199)
      (IF (P100 AND $40) EQ 0 SYMBOL 22,380,P199 ELSE SYMBOL 21,380,P199)
      (IF (P100 AND $80) EQ 0 SYMBOL 22,430,P199 ELSE SYMBOL 21,430,P199)
      (IF (P100 AND $100) EQ 0 SYMBOL 22,480,P199 ELSE SYMBOL 21,480,P199)
      (IF (P100 AND $200) EQ 0 SYMBOL 22,530,P199 ELSE SYMBOL 21,530,P199)
      (RET)
;
;Part 3 (status of the outputs)
N300 (PAGE3)
      (KEY = 0)
N310 (P100=PLCO1)
      (P199=85)
      (CALL 3)
      (P100=PLCO10)
      (P199=155)
      (CALL 3)
      (IF KEY EQ $FFA5 GOTO N200)
      (IF KEY EQ $FFAF GOTO N400)
      (GOTO N310)
;
      (SUB 3)
      (IF (P100 AND 1) EQ 0 SYMBOL 22,105,P199 ELSE SYMBOL 21,105,P199)
      (IF (P100 AND 2) EQ 0 SYMBOL 22,155,P199 ELSE SYMBOL 21,155,P199)
      (IF (P100 AND 4) EQ 0 SYMBOL 22,205,P199 ELSE SYMBOL 21,205,P199)
      (IF (P100 AND 8) EQ 0 SYMBOL 22,255,P199 ELSE SYMBOL 21,255,P199)
      (IF (P100 AND $10) EQ 0 SYMBOL 22,305,P199 ELSE SYMBOL 21,305,P199)
      (IF (P100 AND $20) EQ 0 SYMBOL 22,355,P199 ELSE SYMBOL 21,355,P199)
      (IF (P100 AND $40) EQ 0 SYMBOL 22,405,P199 ELSE SYMBOL 21,405,P199)
      (IF (P100 AND $80) EQ 0 SYMBOL 22,455,P199 ELSE SYMBOL 21,455,P199)
      (IF (P100 AND $100) EQ 0 SYMBOL 22,505,P199 ELSE SYMBOL 21,505,P199)
      (RET)
;
;Part 4 (motor consumption)
N400 (PAGE 4)
      (KEY = 0)
N410 (SYMBOL ABS ROUND (ANAI1/0.5), 130, 120)
      (SYMBOL ABS ROUND (ANAI2/0.5), 130, 190)
      (SYMBOL ABS ROUND (ANAI3/0.5), 130, 260)
      (IF KEY EQ $FFA5 GOTO N300)
      (GOTO N410)
;

```

Machining a pulley.

This example shows:

a.- How to create a subroutine to execute the pulley.

In the example, the program contains the subroutine to execute the pulley (Subroutine 50).
The dimensions of the pulley must be defined by the user before calling upon this subroutine.

b.- How to create a user screen customizing program.

In order to be able to execute this program in the user channel of the Editing mode, general machine parameter «USEREDIT» must be set with the program number.

Once all the data of the pulley have been defined, this program generates, in the program being edited, all the blocks necessary to execute the desired pulley.

c.- How to create a user screen (page).

This program uses page 50 which is the screen shown at the CNC when selecting the «User editor» option in the Editor Mode.

Pulley executing subroutine (Subroutine 50)

The tool data is:

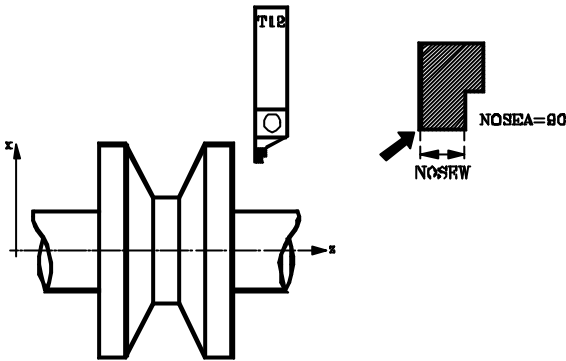

D=12
 F=2
 NOSEA=90
 NOSEW=4
 CUTA=0
 Calibrated for the corner indicated by the arrow.

The Call parameters of the subroutine are:

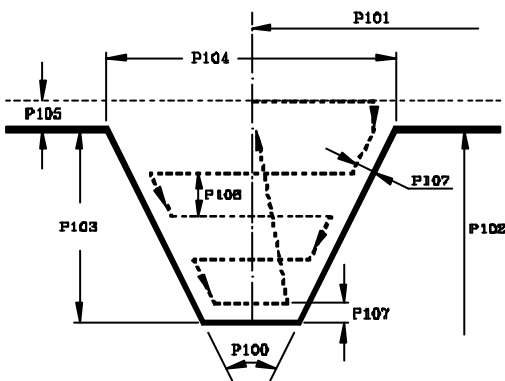

P100 = Angle between the sides of the pulley.
 P101 = Absolute Z center coordinate of the pulley.
 P102 = Outside diameter of the pulley.
 P103 = Depth of the groove (in radius).
 P104 = Width of the groove.
 P105 = Safety distance.
 P106 = Maximum machining depth.
 P107 = Finishing stock.
 P108 = Cutting feedrate.
 P109 = Roughing feedrate in mm/rev.
 P110 = Finishing feedrate mm/rev.

The necessary points for the roughing operation are:

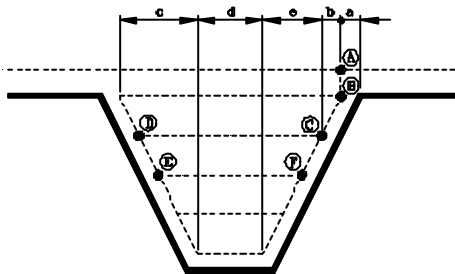

	X	Z
A	$P102 + 2 P105$	$P101 + (P104 / 2) - [P107 / \cos (P100/2)]$
A-B	$- 2 P105$	0
B-C	$- 2 P106$	$- P106 \operatorname{tg} (P100 / 2)$
C-D	0	$- (d + 2e)$
D-E	$- 2 P106$	$P106 \operatorname{tg} (P100 / 2)$
E-F	0	$d + 2e$

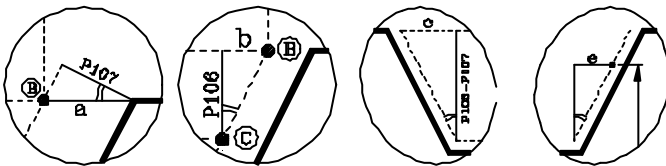

$$a = P107 / \cos(P100/2)$$

$$b = P106 * \operatorname{tg}(P100/2)$$

$$c = (P103 - P107) * \operatorname{tg}(P100/2)$$

$$d = P104 - 2a - 2c$$

$$e = [(x/2) - ((P102/2) - P103 + P107)] * \operatorname{tg}(P100/2)$$

The necessary points for the finishing operation are:

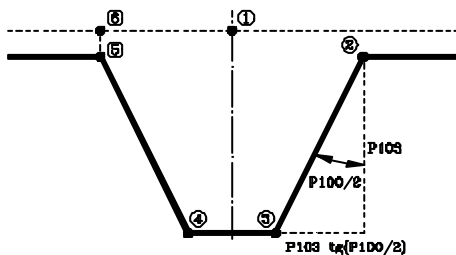

	X	Z
1	$P102 + 2 P105$	$P101$
2	$P102$	$P101 + (P104 / 2)$
3	$P102 - 2P103$	$P101 + (P104 / 2) - P103 \operatorname{tg} (P100 / 2)$
4	$P102 - 2P103$	$P101 - (P104 / 2) + P103 \operatorname{tg} (P100 / 2)$
5	$P102$	$P101 - (P104 / 2)$
6	$P102 + 2 P105$	$P101 - (P104 / 2)$

Program lines of the subroutine:

```

(SUB 50)
  (IF NOSEW12 GT (P104-2*(P107/COS(P100/2))-
    2*(P103-P107)*TAN(P100/2)) ERROR "WRONG DATA") ..... If cutter width > "d" => Error
;-----
; Roughing operation
;-----
(P115=FUP((P103-P107)/P106)) ..... Calculates Nr. of passes (P115).
(P106=(P103-P107)/P115) ..... Recalculates the pass (P106).
G92 S500
G95 G96 FP109 SP108 T12 M4 M41
;
(P1=P102+2*P105, P2=P101+(P104/2)-(P107/COS(P100/2))-NOSEW12)
G G90 XP1 ZP2 ..... Move to point "A"
(P1=2*P105)
G1 G91 X-P1 ..... Movement "A-B"
N50 (P1=2*P106, P2=P106*TAN(P100/2))
  X-P1 Z-P2 ..... Movement "B-C"
  (P2=P104-2*P107/COS(P100/2)-2*(P103-P107)*TAN(P100/2)+
    2*(PPOSX/2-(P102/2-P103+P107))*TAN(P100/2)-NOSEW12)
  Z-P2 ..... Movement "C-D"
  (P115=P115-1) ..... Counts down Nr. of passes
  (IF P115 LE 0 GOTO N100) ..... If done with all roughing passes,
  go to finishing stage.

  (P1=2*P106, P2=P106*TAN(P100/2))
  X-P1 ZP2 ..... Movement "D-E"
  (P2=P104-2*(P107/COS(P100/2))-2*(P103-P107)*TAN(P100/2)+
    2*(PPOSX/2-(P102/2-P103+P107))*TAN(P100/2)-NOSEW12)
  ZP2 ..... Movement "E-F"
  (P115=P115-1) ..... Counts down Nr. of passes
  (IF P115 GT 0 GOTO N50) ..... If done with all roughing passes,
  go to finishing stage.

;-----
; Roughing operation
;-----
N100 G95 G96 FP110 SP108
  (P1=P102+2*P105)
  G0 G90 XP1 ZP101 ..... Movement to point "1"
  (P2=P101+(P104/2)-NOSEW12)
  G1 XP102 ZP2 ..... Movement to point "2"
  (P1=P102-2*P103)
  (P2=P101+(P104/2)-P103*TAN(P100/2)-NOSEW12)
  XP1 ZP2 ..... Movement to point "3"
  (P1=P102-2*P103)
  (P2=P101-(P104/2)+P103*TAN(P100/2))
  XP1 ZP2 ..... Movement to point "4"
  (P2=P101-(P104/2))
  XP102 ZP2 ..... Movement to point "5"
  (P1=P102+2*P105, P2=P101-(P104/2))
  XP1Z P2 ..... Movement to point "6"
  (P1=P102+2*P105)
  XP1 ZP101 ..... Movement to point "1"

```

(RET)

Editing page 50.

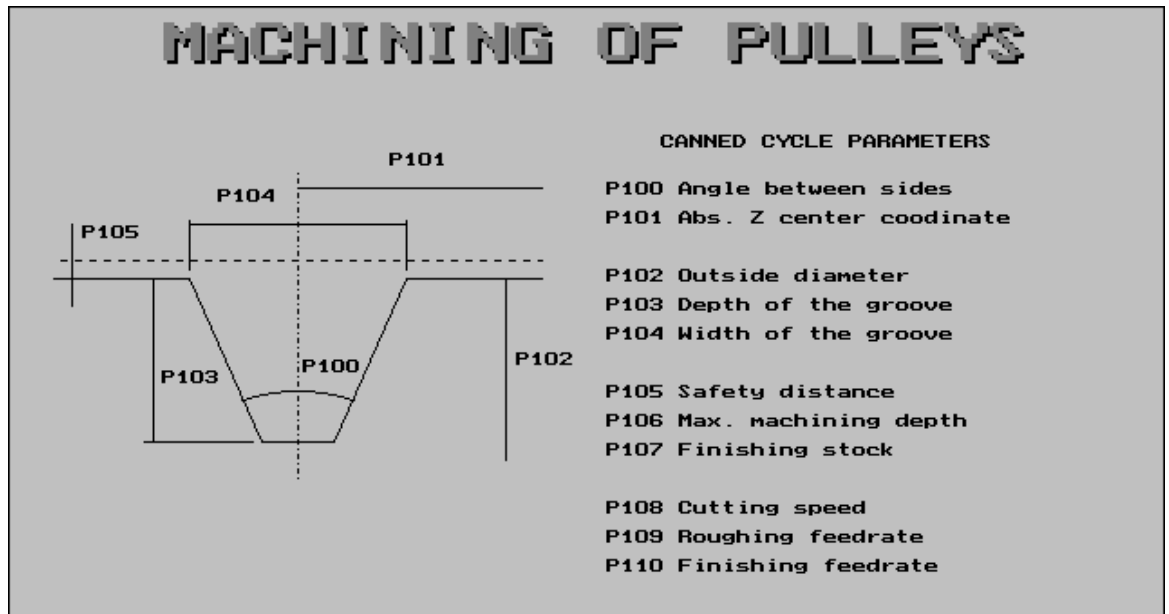

Access the screen customizing mode and select: [Utilities] [Editor] [Page] 50 [Enter]

Select background color: Navy blue.

Edit the following graphic elements:

Element	Main color	Line type	1st corner	2nd corner
Polyline	Light green	Thick solid	X25 Y150	X100 Y150
			X140 Y240	X180 Y240
			X220 Y150	X295 Y150
Line	White	Dashed	X25 Y140	X295 Y140
Line	White	Dot-dashed	X160 Y90	X160 Y260
Arc	White	Solid	X130 Y217.5	X190 Y217.5
			Move to...	X160 Y210

Element	Main color	Line type	1st corner	2nd corner
Line	White	Solid	X160 Y100	X295 Y100
Line	White	Solid	X275 Y150	X275 Y250
Line	White	Solid	X75 Y240	X135 Y240
Line	White	Solid	X80 Y150	X80 Y240
Line	White	Solid	X100 Y145	X100 Y115
Line	White	Solid	X220 Y145	X220 Y115
Line	White	Solid	X100 Y120	X220 Y120
Line	White	Solid	X35 Y165	X35 Y120

Edit the following texts:

Main color	Size	Text	Position
White	Large	MACHINING OF PULLEYS	X87 Y10
Red	Large	MACHINING OF PULLEYS	X85 Y8
White	Small	P100	X162 Y194
White	Small	P101	X210 Y80
White	Small	P102	X280 Y190
White	Small	P103	X84 Y200
White	Small	P104	X115 Y100
White	Small	P105	X40 Y120
White	Small	CANNED CYCLE PARAMETERS	X360 Y96
Light blue	Small	P100 Angle between sides	X330 Y96

Main color	Size	Text	Position
Light blue	Small	P101 Abs. Z center coordinate	X330 Y112
Light blue	Small	P102 Outside diameter	X330 Y144
Light blue	Small	P103 Depth of the groove	X330 Y160
Light blue	Small	P104 Width of the groove	X330 Y176
Light blue	Small	P105 Safety distance	X330 Y208
Light blue	Small	P106 Max. machining deep	X330 Y224
Light blue	Small	P107 Finishing stock	X330 Y240
Light blue	Small	P108 Cutting speed	X330 Y272
Light blue	Small	P109 Roughing feedrate	X330 Y288
Light blue	Small	P110 Finishing feedrate	X330 Y304



	Requests P108 Cutting speed
N18	(SK1="", SK2="", SK3="", SK4="", SK5="", SK6="", SK7="") (IB8=INPUT "Cutting speed:", 3.5) (DW8=IB8) (GOTO N2)
	Requests P109 Roughing feedrate in mm/rev.
N19	(SK1="", SK2="", SK3="", SK4="", SK5="", SK6="", SK7="") (IB9=INPUT "Roughing feedrate in mm/rev.:", 6.5) (DW9=IB9) (GOTO N2)
	Requests P110 Finishing feedrate in mm/rev.
N20	(SK1="", SK2="", SK3="", SK4="", SK5="", SK6="", SK7="") (IB10=INPUT "Finishing feedrate in mm/rev.:", 6.5) (DW10=IB10) (GOTO N2)
	Generates program blocks
N100	(WBUF "(PCALL 50, P100=", IB0) (WBUF ", P101=", IB1) (WBUF ", P102=", IB2) (WBUF ", P103=", IB3) (WBUF ", P104=", IB4) (WBUF ", P105=", IB5) (WBUF ", P106=", IB6) (WBUF ", P107=", IB7) (WBUF ", P108=", IB8) (WBUF ", P109=", IB9) (WBUF ", P110=", IB10) (WBUF ")") (WBUF) (SYSTEM)

	Requests P102 Outside diameter of the pulley
N12	(SK1="", SK2="", SK3="", SK4="", SK5="", SK6="", SK7="") (IB2=INPUT "Outside diameter of the pulley:", 6.5) (DW2=IB2) (GOTO N1)
	Requests P103 Depth of the pulley (in radius)
N13	(SK1="", SK2="", SK3="", SK4="", SK5="", SK6="", SK7="") (IB3=INPUT "Depth of the groove (in radius):", 6.5) (DW3=IB3) (GOTO N1)
	Requests P104 Width of the groove
N14	(SK1="", SK2="", SK3="", SK4="", SK5="", SK6="", SK7="") (IB4=INPUT "Width of the groove:", 6.5) (DW4=IB4) (GOTO N1)
	Requests P105 Safety distance
N15	(SK1="", SK2="", SK3="", SK4="", SK5="", SK6="", SK7="") (IB5=INPUT "Safety distance:", 6.5) (DW5=IB5) (GOTO N1)
	Requests P106 Maximum cutting pass
N16	(SK1="", SK2="", SK3="", SK4="", SK5="", SK6="", SK7="") (IB6=INPUT "Maximum cutting pass:", 6.5) (DW6=IB6) (GOTO N2)
	Requests P107 Finishing stock
N17	(SK1="", SK2="", SK3="", SK4="", SK5="", SK6="", SK7="") (IB7=INPUT "Finishing stock:", 6.5) (DW7=IB7) (GOTO N2)