

CNC 8055 / CNC 8055i



FAGOR 

REF. 0901

.T. MODEL
(SOFT V16.1X)

PROGRAMMING MANUAL

.T. Model
(Soft V16.1x)

Ref. 0901

All rights reserved. No part of this documentation may be transmitted, transcribed, stored in a backup device or translated into another language without Fagor Automation's consent.

The information described in this manual may be changed due to technical modifications. Fagor Automation reserves the right to make any changes to the contents of this manual without prior notice.

Microsoft and Windows are registered trademarks of Microsoft Corporation, U.S.A. The other trademarks belong to their respective owners.

The content of this manual and its validity for the product described here has been verified. Even so, involuntary errors are possible, thus no absolute match is guaranteed. Anyway, the contents of the manual is periodically checked making and including the necessary corrections in a future edition.

The examples described in this manual are for learning purposes. Before using them in industrial applications, they must be properly adapted making sure that the safety regulations are fully met.

INDEX

About the product.....	I
Declaration of conformity.....	III
Version history (T).....	V
Safety conditions.....	XV
Warranty terms.....	XIX
Material returning terms.....	XXI
Additional remarks.....	XXIII
Fagor documentation.....	XXV

CHAPTER 1 GENERAL CONCEPTS

1.1 Part programs.....	2
1.1.1 Considerations regarding the Ethernet connection.....	4
1.2 DNC connection.....	5
1.3 Communication protocol via DNC or peripheral device.....	5

CHAPTER 2 CREATING A PROGRAM

2.1 Program structure at the CNC.....	8
2.1.1 Block header.....	8
2.1.2 Program block.....	9
2.1.3 End of block.....	10

CHAPTER 3 AXES AND COORDINATE SYSTEMS

3.1 Axis nomenclature.....	11
3.1.1 Axis selection.....	12
3.2 Plane selection (G16, G17, G18, G19).....	13
3.3 Part dimensioning. Millimeters (G71) or inches (G70).....	14
3.4 Absolute/incremental programming (G90, G91).....	15
3.5 Programming in radius or in diameters (G152, G151).....	16
3.6 Coordinate programming.....	17
3.6.1 Cartesian coordinates.....	17
3.6.2 Polar coordinates.....	18
3.6.3 Angle and Cartesian coordinate.....	20
3.7 Rotary axes.....	21
3.8 Work zones.....	22
3.8.1 Definition of the work zones.....	22
3.8.2 Using the work zones.....	23

CHAPTER 4 REFERENCE SYSTEMS

4.1 Reference points.....	25
4.2 Machine reference (Home) search (G74).....	26
4.3 Programming with respect to machine zero (G53).....	27
4.4 Coordinate preset and zero offsets.....	28
4.4.1 Coordinate preset and S value limitation (G92).....	29
4.4.2 Zero offsets (G54..G59 and G159).....	30
4.5 Polar origin preset (G93).....	32

CHAPTER 5 ISO CODE PROGRAMMING

5.1 Preparatory functions.....	34
5.2 Feedrate F.....	36
5.2.1 Feedrate in mm/min or inches/min (G94).....	37
5.2.2 Feedrate in mm/rev.or inches/rev (G95).....	38
5.3 Spindle speed (S).....	39
5.3.1 Constant surface speed (G96).....	39
5.3.2 Spindle speed in rpm (G97).....	39
5.4 Spindle selection (G28, G29).....	40
5.5 Synchronized spindles (G30, G77S, G78S).....	41
5.6 Tool number (T) and tool offset (D).....	42



CNC 8055
CNC 8055i

.T- MODEL
(SOFT V16.1x)

5.7	Auxiliary function (M).....	44
5.7.1	M00. Program stop.....	45
5.7.2	M01. Conditional program stop.....	45
5.7.3	M02. End of program.....	45
5.7.4	M30. End of program with return to the first block.....	45
5.7.5	M03 Clockwise spindle rotation.....	45
5.7.6	M04. Counterclockwise spindle rotation.....	45
5.7.7	M05. Spindle stop.....	45
5.7.8	M06. Tool change code.....	46
5.7.9	M19. Spindle orientation.....	46
5.7.10	M41, M42, M43, M44. Spindle gear change.....	47
5.7.11	M45. Auxiliary spindle / Live tool.....	47

CHAPTER 6

PATH CONTROL

6.1	Rapid traverse (G00).....	49
6.2	Linear interpolation (G01).....	50
6.3	Circular interpolation (G02, G03).....	51
6.4	Circular interpolation with absolute arc center coordinates (G06).....	55
6.5	Arc tangent to previous path (G08).....	56
6.6	Arc defined by three points (G09).....	57
6.7	Helical interpolation.....	58
6.8	Tangential entry at the beginning of a machining operation (G37).....	59
6.9	Tangential exit at the end of a machining operator (G38).....	61
6.10	Automatic radius blend (G36).....	62
6.11	Chamfer (G39).....	63
6.12	Threading (G33).....	64
6.13	Withdrawal of axes when interrupting a threading operation (G233).....	67
6.14	Variable pitch threads (G34).....	69
6.15	Activates the C axis (G15).....	70
6.15.1	Machining on the side of the part.....	70
6.15.2	Machining on the face of the part.....	72
6.16	Move to hardstop (G52).....	73
6.17	Feedrate "F" as an inverted function of time (G32).....	74
6.18	Tangential control (G45).....	75
6.18.1	Considerations about the G45 function.....	77
6.19	G145. Temporary cancellation of tangential control.....	78

CHAPTER 7

ADDITIONAL PREPARATORY FUNCTIONS

7.1	Interruption of block preparation (G04).....	79
7.1.1	G04 K0: Block preparation interruption and coordinate update.....	81
7.2	Dwell (G04 K).....	82
7.3	Working with square (G07) and round (G05,G50) corners.....	83
7.3.1	G07 (square corner).....	83
7.3.2	G05 (round corner).....	84
7.3.3	Controlled round corner (G50).....	85
7.4	Look-ahead (G51).....	86
7.4.1	Advanced look-ahead algorithm (integrating Fagor filters).....	88
7.4.2	Look-ahead operation with Fagor filters active.....	89
7.4.3	Smoother machining feedrate.....	89
7.5	Mirror image (G10, G11, G12, G13, G14).....	90
7.6	Scaling factor (G72).....	91
7.6.1	Scaling factor applied to all axes.....	92
7.6.2	Scaling factor applied to one or more axes.....	93
7.7	Electronic axis coupling/uncoupling.....	95
7.7.1	Electronic axis coupling, slaving, (G77).....	95
7.7.2	Cancellation of the electronic axis coupling, slaving, (G78).....	96
7.8	Axes toggle G28-G29.....	97

CHAPTER 8

TOOL COMPENSATION

8.1	Tool length compensation.....	99
8.2	Tool radius compensation.....	100
8.2.1	The location code of the tool (tool type).....	101
8.2.2	Working without tool radius compensation.....	104
8.2.3	Working with tool radius compensation.....	106
8.2.4	Beginning of tool radius compensation (G41, G42).....	107
8.2.5	Sections of tool radius compensation.....	110
8.2.6	Cancellation of tool radius compensation (G40).....	111
8.2.7	Temporary cancellation of tool compensation with G00.....	115
8.2.8	Change of type of tool radius compensation while machining.....	117
8.2.9	Tool compensation in any plane.....	118
8.3	Collision detection (G41 N, G42 N).....	119



CNC 8055
CNC 8055i

.T- MODEL
(SOFT V16.1x)

CHAPTER 9

CANNED CYCLES

9.1	G66. Pattern repeat cycle canned cycle.....	122
9.1.1	Basic operation.....	125
9.1.2	Profile programming syntax.....	127
9.2	G68. X axis roughing canned cycle.....	128
9.2.1	Basic operation.....	131
9.2.2	Profile programming syntax.....	134
9.3	G69. Z axis roughing canned cycle.....	135
9.3.1	Basic operation.....	138
9.3.2	Profile programming syntax.....	141
9.4	G81. Turning canned cycle for straight sections.....	142
9.4.1	Basic operation.....	144
9.5	G82. Facing canned cycle for straight sections.....	146
9.5.1	Basic operation.....	148
9.6	G83. Axial drilling and tapping canned cycle.....	150
9.6.1	Basic operation.....	152
9.7	G84. Turning canned cycle for curved sections.....	154
9.7.1	Basic operation.....	156
9.8	G85. Facing canned cycle for curved sections.....	158
9.8.1	Basic operation.....	160
9.9	G86. Longitudinal threading canned cycle.....	162
9.9.1	Basic operation.....	166
9.10	G87. Face threading canned cycle.....	167
9.10.1	Basic operation.....	171
9.11	G88. X axis grooving canned cycle.....	172
9.11.1	Basic operation.....	173
9.12	G89. Z axis grooving canned cycle.....	174
9.12.1	Basic operation.....	175
9.13	G60. Axial drilling / tapping (on the face).....	176
9.13.1	Basic operation.....	178
9.14	G61. Radial drilling/ tapping (on the side of the part).....	180
9.14.1	Basic operation.....	182
9.15	G62. Slot milling canned cycle on the side of the part.....	184
9.15.1	Basic operation.....	185
9.16	G63. Slot milling canned cycle on the face of the part.....	186
9.16.1	Basic operation.....	187

CHAPTER 10

PROBING

10.1	Probing (G75, G76).....	190
10.2	Probing canned cycles.....	191
10.3	PROBE 1. Tool calibration canned cycle.....	192
10.3.1	Basic operation.....	195
10.4	PROBE 2. Probe calibration canned cycle.....	198
10.4.1	Basic operation.....	199
10.5	PROBE 3. Canned cycle for part measuring and tool correction on the X axis.....	201
10.5.1	Basic operation.....	202
10.6	PROBE 4. Canned cycle for part measuring and tool correction on the Z axis.....	203
10.6.1	Basic operation.....	204

CHAPTER 11

HIGH-LEVEL LANGUAGE PROGRAMMING

11.1	Lexical description.....	205
11.2	Variables.....	207
11.2.1	General purpose parameters or variables.....	209
11.2.2	Variables associated with tools.....	211
11.2.3	Variables associated with zero offsets.....	214
11.2.4	Variables associated with machine parameters.....	216
11.2.5	Variables associated with work zones.....	217
11.2.6	Variables associated with feedrates.....	218
11.2.7	Variables associated with coordinates.....	220
11.2.8	Variables associated with electronic handwheels.....	222
11.2.9	Variables associated with feedback.....	224
11.2.10	Variables associated with the main spindle.....	225
11.2.11	Variables associated with the second spindle.....	227
11.2.12	Variables associated with the live tool.....	229
11.2.13	PLC related variables.....	230
11.2.14	Variables associated with local parameters.....	232
11.2.15	Sercos variables.....	233
11.2.16	Software & hardware configuration variables.....	234
11.2.17	Variables associated with telediagnosis.....	237
11.2.18	Operating-mode related variables.....	239
11.2.19	Other variables.....	242
11.3	Constants.....	246



**CNC 8055
CNC 8055i**

.T- MODEL
(SOFT V16.1x)

11.4	Operators	246
11.5	Expressions	248
11.5.1	Arithmetic expressions	248
11.5.2	Relational expressions	249

CHAPTER 12

PROGRAM CONTROL INSTRUCTIONS

12.1	Assignment instructions	252
12.2	Display instructions	253
12.3	Enable-disable instructions	254
12.4	Flow control instructions	255
12.5	Subroutine instructions	257
12.6	Probe related instructions	261
12.7	Interruption-subroutine instructions	262
12.8	Program instructions	263
12.9	Screen customizing instructions	266

CHAPTER 13

ANGULAR TRANSFORMATION OF AN INCLINE AXIS

13.1	Turning angular transformation on and off	275
13.2	Freezing the angular transformation	276

APPENDIX

A	ISO code programming	279
B	Program control instructions	281
C	Summary of internal CNC variables	285
D	Key codes	293
E	Programming assistance screens of the system	303
F	Maintenance	307



CNC 8055
CNC 8055i

.T- MODEL
(SOFT V16.1X)

ABOUT THE PRODUCT

Basic characteristics of the different models.

	8055i/ A 8055 /A	8055i Plus 8055 Plus
Built-in	8055i/ A	8055i Plus
Enclosure	8055 /A	8055 Plus
USB	8055i/ A	8055i Plus
Block processing time without CPU turbo	9 ms	3 ms
* Block processing time with CPU turbo	----	1.5 ms
RAM memory	256 Kb expandable to 1Mb	1 Mb
Software for 7 axes	----	Option
Digitizing	Option	Standard
Tracing	----	Option
TCP transformation	----	Option
C axis (Lathe)	----	Option
Y axis (Lathe)	----	Option
1M RAM - 2M Flash	Option	----

* Models 8055i /A and 8055i Plus do not have CPU turbo.

Hardware options of the 8055i CNC.

	Analog	Digital
Hard disk / compact flash	Option	Option
Ethernet	Option	Option
1M RAM - 2M Flash	Option	Option
RS-232 serial line.	Standard	Standard
16 digital inputs and 8 outputs (I1 to I16 and O1 to O8)	Standard	Standard
Another 40 digital inputs and 24 outputs (I65 to I104 and O33 to O56)	Option	Option
Probe inputs	Standard	Standard
Spindle (feedback input and analog output)	Standard	Standard
Electronic handwheels	Standard	Standard
4 axes (feedback and analog voltage)	Option	Option
Remote CAN modules, for digital I/O expansion (RIO).	Option	Option
Sercos servo drive system for Fagor servo drive connection.	---	Option
CAN servo drive system for Fagor servo drive connection.	---	Option



Before start-up, verify that the machine that integrates this CNC meets the 89/392/CEE Directive.

FAGOR

CNC 8055
CNC 8055i

Software options of the 8055 and 8055i CNCs.

	Model						
	GP	M	MC	MCO	T	TC	TCO
Number of axes with standard software	4	4	4	4	2	2	2
Number of axes with optional software	7	7	7	7	4 or 7	4 or 7	4 or 7
Electronic threading	-----	Stand	Stand	Stand	Stand	Stand	Stand
Tool magazine management:	-----	Stand	Stand	Stand	Stand	Stand	Stand
Machining canned cycles	-----	Stand	Stand	-----	Stand	Stand	-----
Multiple machining	-----	Stand	Stand	-----	-----	-----	-----
Solid graphics	-----	Stand	Stand	Stand	Stand	Stand	Stand
Rigid tapping	-----	Stand	Stand	Stand	Stand	Stand	Stand
Tool live monitoring	-----	Opt	Opt	Opt	Opt	Opt	Opt
Probing canned cycles	-----	Opt	Opt	Opt	Opt	Opt	Opt
DNC	Stand	Stand	Stand	Stand	Stand	Stand	Stand
COCOM version	Opt	Opt	Opt	Opt	Opt	Opt	Opt
Profile editor	Stand	Stand	Stand	Stand	Stand	Stand	Stand
Tool radius compensation	Stand	Stand	Stand	Stand	Stand	Stand	Stand
Tangential control	Opt	Opt	Opt	Opt	Opt	Opt	Opt
Retracing	-----	Opt	Opt	Opt	Opt	Opt	Opt
Setup assistance	Stand	Stand	Stand	Stand	Stand	Stand	Stand
Irregular pockets with islands	-----	Stand	Stand	Stand	-----	-----	-----
Digitizing	-----	Opt	Opt	Opt	-----	-----	-----
Tracing	-----	Opt	Opt	Opt	-----	-----	-----
TCP transformation	-----	Opt	Opt	Opt	-----	-----	-----
C axis (on Lathe)	-----	-----	-----	-----	Opt	Opt	Opt
Y axis (on Lathe)	-----	-----	-----	-----	Opt	Opt	Opt
Telediagnosis	Opt	Opt	Opt	Opt	Opt	Opt	Opt

About the product



CNC 8055
CNC 8055i

DECLARATION OF CONFORMITY

The manufacturer:

Fagor Automation S. Coop.

Barrio de San Andrés 19, C.P. 20500, Mondragón -Guipúzcoa- (SPAIN).

We declare:

We declare under our exclusive responsibility the conformity of the product:

Numerical Control Fagor 8055 and 8055i

Referred to by this declaration with following directives:

Safety regulations.

EN 60204-1 Machine safety. Electrical equipment of the machines.

Regulation on electromagnetic compatibility.

EN 61000-6-4 Generic regulation on emissions in industrial environments.

EN 55011 Radiated. Class A, Group 1.

(*) EN 55011 Conducted. Class A, Group 1.

(*) EN 61000-3-2 Current armonics.

(*) EN 61000-3-3 Flickers and Voltage fluctuations.

EN 61000-6-2 Generic regulation on immunity in industrial environments.

EN 61000-4-2 Electrostatic discharges.

EN 61000-4-3 Radiofrequency radiated electromagnetic fields.

EN 61000-4-4 Bursts and fast transients.

(*) EN 61000-4-5 High Voltage conducted pulses (Surges).

EN 61000-4-6 Conducted disturbance induced by radio frequency fields.

EN 61000-4-8 Magnetic fields to Mains frequency.

EN 61000-4-11 Voltage fluctuations and Outages.

ENV 50204 Fields generated by digital radio-telephones.

(*) Only for the 8055 model

As instructed by the European Community Directives: 73/23/CEE modified by 93/68/EEC on Low Voltage and 89/336/CEE modified by 92/31/EEC and 93/68/EEC on Electromagnetic Compatibility and their updates.

In Mondragón, June 15th 2005.

Fagor Automation S. Coop. Ltda.
Director Gerente

Fdo.: Julen Busturia

FAGOR 

**CNC 8055
CNC 8055i**

VERSION HISTORY (T)

(lathe model)

Here is a list of the features added in each software version and the manuals that describe them.

The version history uses the following abbreviations:

INST	Installation manual
PRG	Programming manual
OPT	Operation manual
OPT-TC	Operation manual for the TC option
OPT-CO	Manual of the CO manual

Software V04.0x

December 1999

List of features	Manual
Portuguese language.	INST
Tangential control.	INST / PRG
Incline planes. Software travel limits are monitored in JOG movements.	
PLC. User registers from R1 to R499.	INST / PRG
Status screen for the CNC.	OPT
Hard disk (HD).	INST
HD diagnosis.	OPT
Integrate the HD into an external computer network.	INST
Check directories, delete, rename and copy programs in the same or another device.	OPT / PRG
Execution and simulation from RAM, Memkey Card, HD or serial line.	OPT
A program stored in any device may be executed (EXEC) and opened for editing.	PRG
Thread repair. Home (reference) the spindle before thread repair.	PRG / OPT-TC
Simulation in rapid, without assuming G95 or M3, or M4a5, etc.	OPT
Geometry associated with tool offset.	INST / OPT
Live tool with M45 or as 2nd spindle.	INST
PLC channel affected by another feedrate set via PLC.	INST
x1, x10, x100 factor independent for each handwheel.	INST / PRG
Fagor HBE handwheel management.	INST
Compatibility between HBE handwheel and individual handwheels.	
Spindle synchronization (G77 S).	INST / PRG
Optimized profile machining	PRG / OPT-TC
Axes (2) controlled by a drive.	INST
G75 affected by feedrate override (%).	INST
Probe. Probe position using cycle parameters	PRG
Temperature and battery voltage detection at the new CPU.	
TC option. ISO management, also like MDI.	OPT-TC
TC option. Coolant icon in all cycles.	OPT-TC
TC option. Background editing.	OPT-TC
TC option. Key codes for user cycles.	OPT-TC

Software V04.02

March 2000

List of features	Manual
Interrupt block preparation in PLC channel.	INST
Handwheels admit differential feedback.	INST
High level. "?" operators in WRITE instruction.	PRG



CNC 8055
CNC 8055i

List of features	Manual
Czech and Polish languages.	INST
Display theoretical spindle rpm.	INST
Five work zones.	INST / PRG
Assign more CPU time for the PLC.	INST / OPT
Software & hardware configuration variables.	INST / PRG
Improved utilities.	OPT
It is managed in like the DDSSETUP.	INST
Jerk control.	INST
Jog mode. Position display.	OPT
Improved work zone management in JOG	
Configurable work mode in M model.	INST
8055 /A model.	

List of features	Manual
Improved RS232 connector (compatible with previous one).	INST
PARTC variable does not increment in simulation.	INST / PRG
Solid graphics. Redraws image after changing conditions.	OPT
New keyboards NMON.55xx-11.LCD.	INST
Czech and Polish languages.	INST
Sercos. SERPOUSE (P121) parameter values.	INST
Variable pitch threads (G34).	PRG

List of features	Manual
Drive parameter (Sercos) editing from the CNC.	
Utilities. Copy or delete groups of programs.	OPT
PLC channel. Feed-hold related marks.	INST
PLC channel. M function management.	INST
PLC channel. Generate programs with PLC axes.	INST
PLC channel. Input buffers for 4 to 12 blocks.	INST
Profile editor. Modify starting point.	OPT
Profile editor. Modify element.	OPT
Profile editor. Delete element.	OPT
Profile editor. Insert element.	OPT
Machine parameter. Update symbols.	INST
Mainland Chinese language	INST
OEM text in several languages.	INST
Keys: Edit, Simul and Exec.	OPT
Rapid-key treatment in execution.	INST
"Wrong validation code" message.	
Tables. Initializations.	OPT
Collision detection.	PRG
New drive parameters.	
Sercos. Second feedback.	INST
Sercos. Axis parking.	
Variables associated with telediagnosis.	INST / PRG
General handwheel inhibits individual handwheels.	INST / PRG
Configuration file. Sabeinsub, Disable 20 and 21.	INST
Deep hole drilling with variable peck.	PRG / OPT
Rigid tapping.	PRG / OPT
Sinusoidal spindle feedback.	INST
Spindle and "C" axis management with a single feedback.	INST
TC option. DIPLCOF parameter is taken into account.	OPT-TC
TC option. Repositioning may be aborted.	OPT-TC
TC option. Avoid undesired executions.	OPT-TC

List of features	Manual
TC option. Icon for spindle turning direction.	INST / OPT-TC
TC option. "S2" representation with second spindle.	OPT-TC
TC option. Finishing stocks in X-Z.	OPT-TC
TC option. Cycle level indicating tab.	OPT-TC
TC option. Threading cycle home angle.	OPT-TC
TC option. P999997 text program management.	OPT-TC

Software V06.2x

December 2001

List of features	Manual
Retracing function.	INST
Circle geometry test.	OPT
Cross compensation with theoretical coordinates (g.m.p. TYPCROSS).	INST
Auxiliary spindle controlled by PLC (g.m.p. AXIS9).	INST
a.m. p. I0CODI1, I0CODI2 for linear encoders with distance-coded reference marks.	INST
Backlash compensation for reversal of moving direction only on circular paths G2/G3.	INST
Handwheel does not accumulate movement (g.m.p. HDIFFBAC).	INST
Change of the functionality of the MENTST variable.	INST / PRG
Subroutine associated with function G15 of "C" axis (g.m.p. G15SUB)	INST
Compile PLC variables with undefined axes.	
Up to 70 characters in error texts generated by PLC.	
TC option. If Feed-hold active, the feedrate changes color.	OPT-TC
CO option. If Feed-hold active, the feedrate changes color.	OPT-CO

Software V06.3x

April 2002

List of features	Manual
New expansion board models for the 8055i.	INST / PRG
Bus CANOpen to control remote digital I/Os at the 8055i	INST / OPT
New PLC instructions. IREMRD and OREMWR.	INST
Leadscrew error compensation on rotary axes between 0-360 degrees.	INST
PLC statistic deletion in a single softkey.	OPT
Absolute reference mark management via Sercos (a.m.p. REFVALUE).	INST

Software V08.0x

December 2002

List of features	Manual
New languages; Basque and Russian.	INST
Additional command pulse. Exponential backlash peak.	INST
Additional command pulse. Eliminate inside backlash peaks when changing quadrants.	INST
Improved non-random tool magazine management.	INST
Proportional and derivative gain with the "C" axis.	INST
Safety limit for the axis feedrate.	INST
Safety limit for the spindle speed.	INST
Execute the additional compensation block at the beginning of the next block.	INST
Path-jog mode.	INST / OPT
Update the variables of the machine parameters from the OEM program or subroutine.	INST / PRG
HARCON variable returns the type of LCD and turbo board.	INST / PRG
Variables to consult the actual (real) and theoretical feedrate of each axis.	INST / PRG
Variable to consult the coordinates shown on the screen for each axis.	INST / PRG
Variable to consult the position indicated by the Sercos drive of each axis.	INST / PRG
Variable to consult the coordinate programmed in a block of a program.	INST / PRG
Variable to consult the position indicated by the Sercos drive of the first and second spindles.	INST / PRG
Variable to consult the theoretical turning speed of the first and second spindles.	INST / PRG
Variable to consult the maximum spindle speed.	INST / PRG
Feedback related variables.	INST / PRG
Variable to consult a single PLC mark.	INST / PRG

Version history (T)



CNC 8055
CNC 8055i

List of features	Manual
Variable to consult the PROBE cycle being executed.	INST / PRG
Variable to know the number of the screen, created with WINDRAW55, that is being consulted.	INST / PRG
Variable to know the number of the item (element), created with WINDRAW55, that is being consulted.	INST / PRG
Machine safety. Hardware errors disable the [CYCLE START] key.	INST
Machine safety. Maximum machining feedrate.	INST
Mandatory axis homing after feedback alarm when using direct feedback.	INST
The "SERCOS816" board is now recognized.	
Write-protect the user arithmetic parameters (P1000-P1255) and OEM arithmetic parameters (P2000-P2255).	INST
New command of the configuration language. UNMODIFIED command.	INST
Synchronize a PLC axis with a CNC axis.	INST
Axes (2) controlled by a drive. The direction of the command LOOPCHG is defined on both axes.	INST
Tool change via PLC.	INST
New user arithmetic parameters (P1000 - P1255).	PRG
New OEM arithmetic parameters (P2000 - P2255).	PRG
RPT instruction. Execute blocks of a program located in RAM memory.	PRG
Look-ahead. It analyzes up to 75 blocks in advance.	PRG
OEM (manufacturer's) subroutines. Range SUB10000 - SUB20000.	PRG
Oscilloscope function.	OPT
Load the version without using an external microprocessor.	OPT
The screen data (feedrates, coordinates, etc.) do not show their zeros to the left.	
Blackbox for registering errors.	OPT
Telediagnosis through the RS232 serial line.	OPT
Telediagnosis via WinDNC.	OPT
Correct tool wear from tool inspection mode.	OPT
Improvements to the profile editor.	OPT
G60, G61 and G63. Minimum drilling peck.	PRG
G86 and G87. "V" parameter for multi-entry threads.	PRG
Save and load the parameters of the Sercos or CAN drive through the serial line.	INST
TC option. Restore the last F, S and Smax values on power-up.	INST
TC option. Possibility of hiding unused operations or cycles.	INST
TC option. Improvements for executing a part-program.	OPT-TC
TC option. It shows warning messages on a green stripe.	OPT-TC
TC option. Limitations to tool calibration when there is a program in execution or in tool inspection mode.	OPT-TC
TC option. Turning cycle. It is now possible to define the finishing stock in X and Z.	OPT-TC
TC option. Turning cycle. New level to define the type of corner.	OPT-TC
TC option. Facing cycle. It is now possible to define the finishing stock in X and Z.	OPT-TC
TC option. Facing cycle. New level to define the type of corner.	OPT-TC
TC option. Taper turning cycle. New level to define the Z distance and the taper angle.	OPT-TC
TC option. Threading cycle. It is possible to define the type of standardized thread (except face threading).	OPT-TC
TC option. Threading cycle. It is possible to repeat the last pass.	OPT-TC
TC option. Threading cycle. New level for multi-entry threads.	OPT-TC
TC option. Grooving cycle. New level for cut-off operations.	OPT-TC
TC option. Profiling cycle. After roughing, it does not withdraw to the safety distance.	OPT-TC
TC option. Profiling cycle. The first point of the profile is assumed as the starting point.	OPT-TC
TC option. Profiling cycle. Finishing stock in XC and ZC profile cycles	OPT-TC
TC option. Profiling cycle. Finishing tool for the XC and ZC cycles.	OPT-TC

Software V08.1x

July 2003



CNC 8055
CNC 8055i

List of features	Manual
New 24-character validation codes.	
8055i model. Pin -9- of connector X1 (RS232 serial line) no longer supplies 5 V.	INST
8055 model. Pin -9- of connector X3 (RS232 serial line) no longer supplies 5 V.	INST
8055 model. -I/O- board fuse is now eliminated.	INST
Smooth stop of probing movement.	INST
Machining in round corner mode when changing the tool offset.	INST
Bi-directional leadscrew compensation.	INST
The management of the distance-coded reference mark via Sercos may be carried out through the drive's second feedback. The drive version must be V4.10 or V5.10 (or greater).	

List of features	Manual
Machine parameters modifiable from an OEM program using variables	INST / OEM
General machine parameters modifiable from the oscilloscope: TLOOK.	OPT
Axis machine parameters that may be modified from the oscilloscope: MAXFEED, JOGFEED.	OPT
Improvements to look ahead. Machining feedrate variations are now smoother thanks to filtered acc/dec.	
G86 and G87. "J" parameter. Thread exit through the last point.	PRG
TC option. Threading cycle. Thread exit through the last point.	OPT-TC

Software V10.0x

February 2004

List of features	Manual
MEM CARD slot as floppy drive (CARD-A).	INST / OPT
Tandem axes.	INST
Stop block preparation when executing a new "T".	INST
Execute the stop signal when done with the "T" change.	INST
8055i model. Compact-flash type hard disk and Ethernet.	INST
8055 model. Compact flash type hard disk and Ethernet integrated into the –CPU– module.	INST
Incline axis.	INST / PRG
Select the behavior of the feedrate for F0.	INST
On Gantry axes, cross compensation is also applied to the slave axis.	INST
8055i model. Variable to select the active probe input.	INST / PRG
Variable to select the programming mode, radius or diameter.	INST / PRG
8055 model. Variable to detect the type of I/O CAN board at COM1 and COM2.	INST / PRG
Variable to know the address of the I/O CAN.	INST / PRG
Variables to read the number of local and remote digital I/O available.	INST / PRG
The HARCON variable recognizes Ethernet and compact flash.	INST / PRG
While compiling the PLC program, the outputs are initialized to zero.	
New marks to park the spindles.	INST
Name the logic inputs and outputs with the axis name	INST
Parameter RAPIDEN assumes the value of -2. Rapid key controlled by PLC.	INST
Ending the execution of a block using a PLC mark (BLOABOR, BLOABORP).	INST
Additive coupling between axes.	INST
The EXEC and OPEN instructions may be used with Ethernet.	PRG
G2/G3. The center coordinates may be left out if their value is zero.	PRG
General parameters that may be modified from the oscilloscope or from an OEM program: CODISET.	INST/PRG/OPT
Axis parameters that may be modified from the oscilloscope or from an OEM program: MAXFLWE1, MAXFLWE2.	INST/PRG/OPT
Connection to a remote hard disk.	INST / OPT
Connection to a PC through WinDNC.	INST / OPT
Access the CNC's hard disk from a PC via FTP.	INST / OPT
Telediagnosis. Normal phone call.	OPT
Telediagnosis. Disable the CNC screen and keyboard from the PC.	OPT
Functions M41 through M44 admit subroutines when the gear change is automatic.	PRG
TC option. Accessing cycles and programs from the auxiliary screen.	INST
TC option. ISO programming assistance.	OPT-TC
TC option. Zero offset table management.	OPT-TC
TC option. Point-to-point profiling cycle. When defining the points of the profile, when leaving a data blank, the cycle assumes that it is the repetition of the previous one.	OPT-TC
TC option. Tool calibration cycle.	OPT-TC
TC option. After an execution or simulation error, it indicates the erroneous cycle.	OPT-TC
TC option. In execution or simulation, it indicates the cycle number.	OPT-TC
TC option. The CNC highlights the axis being moved in jog or with handwheels.	OPT-TC
TC option. Copying a profile.	OPT-TC
TC option. Select a program by indicating its number.	OPT-TC
CO option. Copying a profile.	OPT-CO

Version history (T)



CNC 8055
CNC 8055i

List of features	Manual
Calculation of central unit heat dissipation .	INST
Frequency filters for axes and spindles.	INST
When activating tool radius compensation in the first motion block even if there is no movement of the plane axes.	INST
CAN servo system.	INST
8055 model. New module –Vpp Axes–.	INST
8055i model. New board "Axes2".	INST
Sercos transmission speed at 8 MHz and 16 MHz.	INST
Retracing function. If RETRACAC=2 , the retrace function does not stop at the M functions.	INST
Retracing function. The RETRACAC parameter is initialized with [SHIFT][RESET].	
Retracing function. The number of blocks being retraced has been increased to 75.	INST
New variables for APOS(X-C) and ATPOS(X-C) to consult part coordinates.	INST / PRG
New variable DNCSTA to consult DNC communication status.	INST / PRG
New variable TIMEG to consult the status of the timer programmed with G4.	INST / PRG
Manual intervention with additive handwheel.	INST / OPT
A CNC emergency disables the SPENA signals and the Sercos drive brakes using the emergency ramps.	INST
Maintain G46 when the home search does not involve any axis of the angular transformation.	INST / PRG
COMPMode (P175). New tool radius compensation methods.	INST / PRG
Automatic keyboard type identification.	INST
Variable to indicate whether the handwheel selector button has been pressed or not.	INST / PRG
8055 model. Variable to select the active probe input.	INST / PRG
Protect the access from the network to the hard disk using a password.	INST
The HARCON variable recognizes the new axis board "Axes2".	INST / PRG
Variable to analog the value of the analog inputs.	INST / PRG
New MEXEC instruction. Execute a modal part-program.	PRG
Look-ahead. Functions G74, G75 and G76 are possible.	PRG
Up to 319 G functions now available.	PRG
Machine parameters that may be modified from the oscilloscope or from an OEM program: REFVALUE, REFDIRC, FLIMIT, SLIMIT.	INST/PRG/OPT
Accessing the variables of the auxiliary spindle drive from the oscilloscope.	OPT
The simulations without axis movement ignore the G4.	OPT
Sharing the CNC's hard disk with password.	INST / OPT
Telediagnosis. Advanced phone call.	OPT
Telediagnosis through the Internet.	OPT
Telediagnosis. Disconnect the CNC from the Ethernet during telediagnosis.	OPT
Maintain the feedrate selected in simulation.	OPT
When the C axis is active, the position of the X-C axes referred to part zero correspond to the transformed coordinates.	OPT
Incline axis transformation is maintained after activating the C axis.	PRG
G151-G152. Programming in diameter or radius.	PRG
TC option. Displaying the transformed coordinates with the C axis active.	OPT-TC

Software V10.13

April 2005

List of features	Manual
New table to define the Sercos power with the Sercos816 board.	INST
600 µs delay at the Sercos bus for transmissions at 8 MHz and 16 MHz.	INST
Hirth axis pitch may be set in degrees via parameters.	INST
Rollover positioning axis. Movement in G53 via the shortest way.	INST

Software V10.14

May 2005

List of features	Manual
New table to define the Sercos power with the Sercos816 board.	INST



CNC 8055
CNC 8055i

List of features	Manual
Analog I/O expansion and PT100.	INST
CAN bus speed with remote digital I/O modules.	INST
The CNC supports Memkey Card + Compact Flash or KeyCF.	OPT
File explorer to show the contents of the storage devices.	INST / OPT
Loading the version from the Memkey card or from the hard disk.	OPT
New way to search home that may be selected through g.m.p. I0TYPE=3.	INST
Improved block search. Switching from simulation to execution.	INST / OPT
New repositioning mode that is activated by setting g.m.p. REPOSTY=1.	INST/PRG/OPT
Square-sine ramps on open-loop spindle.	INST
Numbering of the local inputs/outputs of the expansion modules using plc machine parameters.	INST
Default value of axis and spindle machine parameter ACFGAIN = YES.	INST
Setting axis parameters FFGAIN and FFGAIN2 with two decimals.	INST
Up to 400 (DEF) symbols now available at the PLC.	INST
New HTOR variable that indicates the tool radius being used by the CNC.	INST / PRG
Spindle override in the whole threading cycle at 100%.	PRG
Y axis as software option.	INST
Improved grooving cycles. Two new icons in roughing parameters.	OPT-TC
Generating an ISO-coded program.	OPT-TC

List of features	Manual
New models 8055i /A, 8055i Plus and 8055 Plus.	INST
Compact CPU hardware. New functions.	INST
Automatic keyboard type identification.	INST / PRG
New G145. Temporary cancellation of tangential control.	PRG
Handwheel feedback taken to a free feedback connector.	INST
New variables: RIP, GGSE, GGSF, GGSG, GGSH, GGSJ, GGSK, GGSL, GGSM, PRGSP, SPRGSP and PRBMOD.	INST
G04 K0. Block preparation interruption and coordinate update.	PRG
Possibility to view all the active PLC messages.	OPT-TC
In the cycles, when selecting CSS, the screen shows "CSS" instead of "S"	OPT-TC
Icon for coolant ON/OFF in positioning cycles 1 and 2.	OPT-TC

List of features	Manual
Smooth stop when homing the axes, it may be selected with a.m.p. I0TYPE.	INST

List of features	Manual
Block processing time of 8055/A models down to 9 ms.	INST
Selecting the additive handwheel as handwheel associated with the axis.	INST

List of features	Manual
Copy and execute programs on Hard Disk (KeyCF).	OPT
New axis module AXES VPP SB.	INST

List of features	Manual
Home search on SERCOS axes using absolute feedback.	INST

List of features	Manual
Display of PLC or CNC messages in Russian and Chinese.	INST
New axis module AXES VPP SB.	INST
New FAGOR filters.	INST
Leadscrew backlash compensation. Compensation peak cutting criterion.	INST
Home search on Gantry axes (managing two home switches).	INST
Automatic spindle homing with the first M3/M4.	OPT
Allow two "switched" axes to have different gear ratios.	INST
Look-Ahead. Angle below which, it machines in square corner mode.	PRG
Teach-in. Execution of the edited block.	OPT
Improvements to the oscilloscope and direct access from jog and execution modes.	OPT
Editing on hard disk (KeyCF)	OPT
Data safety backup. Backup - Restore.	OPT
New set of gains and accelerations.	INST
MSGFILE: Number of PLC messages and errors expanded to 255 and 128 respectively.	INST / OPT
Improvements to the profile editor.	OPT
Faster rigid tapping without sending M functions to the PLC.	INST
Withdrawal of axes when interrupting a threading operation.	INST / PRG
Spindle override change while threading.	INST / PRG
Threading in blind threads (without thread exit).	OPT / PRG
Jogging in G95.	PRG

List of features	Manual
Do not execute a program sent via DNC until pressing START.	INST
Select the set of gains and accelerations to be used in a home search.	INST
Prevent motion blocks from being executed in square corner mode.	INST / PRG
There are now more zero offsets.	PRG
The labels can now have 8 digits.	PRG
Editing on hard disk (KeyCF) on CNC's without memory expansion.	OPT
Drilling canned cycles at the GP model.	
PROBE1. Tool wear measurement.	PRG

List of features	Manual
Spindle home search on the next revolution after detecting that the home switch has been pressed.	INST
Home search on SERCOS axes using absolute feedback.	INST
Defining a helical interpolation without programming the final coordinate of the axes of the plane.	PRG
Starting the CNC up while FAGOR filters are active.	INST
Larger numeric format to define the arc center in a G2/G3.	PRG
Monitoring the offset between the spindle and the longitudinal axis during rigid tapping.	INST / OPT
Hysteresis in the reversal movement compensation command.	INST
New default value for a.m.p. INPOSW2 (P51).	INST
Setting the CNC in Turkish.	INST
G86/G87. Threading cycles with variable pitch.	PRG

List of features	Manual
Improved Look-Ahead function: <ul style="list-style-type: none"> Advanced look-ahead algorithm (integrating FAGOR filters). Look-ahead operation with FAGOR filters active. Smoother machining speed. 	INST / PRG



Version history (T)



CNC 8055
CNC 8055i

SAFETY CONDITIONS

Read the following safety measures in order to prevent harming people or damage to this product and those products connected to it.

This unit may only be repaired by authorized personnel at Fagor Automation.

Fagor Automation shall not be held responsible of any physical damage or defective unit resulting from not complying with these basic safety regulations.

Precautions against personal damage

- ❑ Interconnection of modules
Use the connection cables provided with the unit.
- ❑ Use proper Mains AC power cables
To avoid risks, use only the Mains AC cables recommended for this unit.
- ❑ Avoid electrical overloads
In order to avoid electrical discharges and fire hazards, do not apply electrical voltage outside the range selected on the rear panel of the central unit.
- ❑ Ground connection
In order to avoid electrical discharges, connect the ground terminals of all the modules to the main ground terminal. Before connecting the inputs and outputs of this unit, make sure that all the grounding connections are properly made.
- ❑ Before powering the unit up, make sure that it is connected to ground
In order to avoid electrical discharges, make sure that all the grounding connections are properly made.
- ❑ Do not work in humid environments
In order to avoid electrical discharges, always work under 90% of relative humidity (non-condensing) and 45 °C (113° F).
- ❑ Do not work in explosive environments
In order to avoid risks or damages, do no work in explosive environments.

Precautions against product damage

- ❑ Working environment
This unit is ready to be used in industrial environments complying with the directives and regulations effective in the European Community.
Fagor Automation shall not be held responsible for any damage suffered or caused when installed in other environments (residential or homes).



CNC 8055
CNC 8055i

❑ Install this unit in the proper place

It is recommended, whenever possible, to install the CNC away from coolants, chemical product, blows, etc. that could damage it.

This unit complies with the European directives on electromagnetic compatibility. Nevertheless, it is recommended to keep it away from sources of electromagnetic disturbance such as:

- Powerful loads connected to the same AC power line as this equipment.
- Nearby portable transmitters (Radio-telephones, Ham radio transmitters).
- Nearby radio/TV transmitters.
- Nearby arc welding machines.
- Nearby High Voltage power lines.
- Etc.

❑ Enclosures

The manufacturer is responsible of assuring that the enclosure involving the equipment meets all the currently effective directives of the European Community.

❑ Avoid disturbances coming from the machine tool

The machine-tool must have all the interference generating elements (relay coils, contactors, motors, etc.) uncoupled.

- DC relay coils. Diode type 1N4000.
- AC relay coils. RC connected as close to the coils as possible with approximate values of $R=220\ \Omega$ / 1 W and $C=0,2\ \mu\text{F}$ / 600 V.
- AC motors. RC connected between phases, with values of $R=300\ \Omega$ / 6 W and $C=0,47\ \mu\text{F}$ / 600 V.

❑ Use the proper power supply

Use an external regulated 24 Vdc power supply for the inputs and outputs.

❑ Grounding of the power supply

The zero volt point of the external power supply must be connected to the main ground point of the machine.

❑ Analog inputs and outputs connection

It is recommended to connect them using shielded cables and connecting their shields (mesh) to the corresponding pin.

❑ Ambient conditions

The working temperature must be between +5 °C and +40 °C (41°F and 104° F)

The storage temperature must be between -25 °C and +70 °C. (-13 °F and 158 °F)

❑ Monitor enclosure (8055) or central unit (8055i)

Guarantee the required gaps between the monitor or the central unit and each wall of the enclosure. Use a DC fan to improve enclosure ventilation.

❑ Power switch

This power switch must be mounted in such a way that it is easily accessed and at a distance between 0.7 meters (27.5 inches) and 1.7 meters (5.5ft) off the floor.



CNC 8055
CNC 8055i

Protections of the unit itself (8055)

❑ Modules: "Axes", "Inputs/Outputs" and "Inputs/Outputs & Tracing"

All the digital inputs and outputs have galvanic isolation via optocouplers between the CNC circuitry and the outside.

They are protected by an external fast fuse (F) of 3.15 A 250V against overvoltage of the external power supply (over 33 Vdc) and against reverse connection of the power supply.

❑ Monitor

The type of protection fuse depends on the type of monitor. See identification label of the unit itself.

Protections of the unit itself (8055i)

❑ Central unit

It has a 4 A 250V external fast fuse (F).

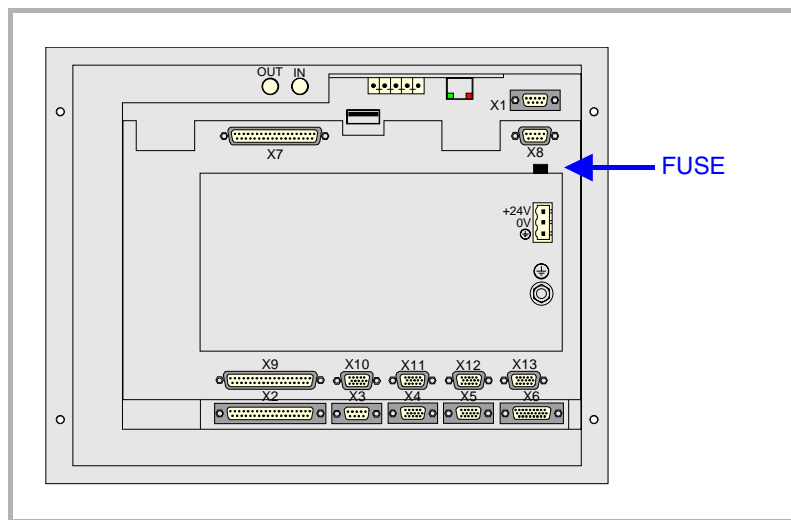

❑ Inputs-Outputs

All the digital inputs and outputs have galvanic isolation via optocouplers between the CNC circuitry and the outside.

Precautions during repair



Do not open this unit. Only personnel authorized by Fagor Automation may open this unit.

Do not handle the connectors with the unit connected to mains. Before manipulating the connectors (inputs/outputs, feedback, etc.) make sure that the unit is not connected to AC power.

Safety symbols

- Symbols which may appear on the manual.



Symbol for danger or prohibition.

It indicates actions or operations that may cause damage to people or to units.



Warning symbol.

It indicates situations that may be caused by certain operations and the actions to be taken to prevent them.



Obligation symbol.

It indicates actions and operations that must be carried out.



Information symbol.

It indicates notes, warnings and advises.

WARRANTY TERMS

Initial warranty

All products manufactured or marketed by FAGOR carry a 12-month warranty for the end user which could be controlled by the our service network by means of the warranty control system established by FAGOR for this purpose.

In order to prevent the possibility of having the time period from the time a product leaves our warehouse until the end user actually receives it run against this 12-month warranty, FAGOR has set up a warranty control system based on having the manufacturer or agent inform FAGOR of the destination, identification and on-machine installation date, by filling out the document accompanying each FAGOR product in the warranty envelope. This system, besides assuring a full year of warranty to the end user, enables our service network to know about FAGOR equipment coming from other countries into their area of responsibility.

The warranty starting date will be the one appearing as the installation date on the above mentioned document. FAGOR offers the manufacturer or agent 12 months to sell and install the product. This means that the warranty starting date may be up to one year after the product has left our warehouse so long as the warranty control sheet has been sent back to us. This translates into the extension of warranty period to two years since the product left our warehouse. If this sheet has not been sent to us, the warranty period ends 15 months from when the product left our warehouse.

This warranty covers all costs of material and labour involved in repairs at FAGOR carried out to correct malfunctions in the equipment. FAGOR undertakes to repair or replace their products within the period from the moment manufacture begins until 8 years after the date on which it disappears from the catalogue.

FAGOR has exclusive competence in deciding whether the repair enters within the term defined as the warranty period.

Excluding clauses

Repairs will be carried out on our premises. Therefore, all expenses incurred as a result of trips made by technical personnel to carry out equipment repairs, despite these being within the above-mentioned period of warranty, are not covered by the warranty.

Said warranty will be applied whenever the equipment has been installed in accordance with instructions, has not be mistreated, has not been damaged by accident or by negligence and has not been tampered with by personnel not authorised by FAGOR. If, once servicing or repairs have been made, the cause of the malfunction cannot be attributed to said elements, the customer is obliged to cover the expenses incurred, in accordance with the tariffs in force.

Other warranties, implicit or explicit, are not covered and FAGOR AUTOMATION cannot be held responsible for other damages which may occur.



CNC 8055
CNC 8055i

Warranty on repairs

In a similar way to the initial warranty, FAGOR offers a warranty on standard repairs according to the following conditions:

PERIOD	12 months.
CONCEPT	Covers parts and labor for repairs (or replacements) at the network's own facilities.
EXCLUDING CLAUSES	The same as those applied regarding the chapter on initial warranty. If the repair is carried out within the warranty period, the warranty extension has no effect.

When the customer does not choose the standard repair and just the faulty material has been replaced, the warranty will cover just the replaced parts or components within 12 months.

For sold parts the warranty is 12 months length.

Maintenance contracts

The SERVICE CONTRACT is available for the distributor or manufacturer who buys and installs our CNC systems.



CNC 8055
CNC 8055i

MATERIAL RETURNING TERMS

When sending the central nit or the remote modules, pack them in its original package and packaging material. If the original packaging material is not available, pack it as follows:

1. Get a cardboard box whose three inside dimensions are at least 15 cm (6 inches) larger than those of the unit. The cardboard being used to make the box must have a resistance of 170 kg. (375 pounds).
2. Attach a label indicating the owner of the unit, person to contact, type of unit and serial number.
3. In case of failure, also indicate the symptom and a short description.
4. Wrap the unit in a polyethylene roll or similar material to protect it.
5. When sending the central unit, protect especially the screen.
6. Pad the unit inside the cardboard box with polyurethane foam on all sides.
7. Seal the cardboard box with packing tape or industrial staples.



CNC 8055
CNC 8055i



Material returning terms



CNC 8055
CNC 8055i

ADDITIONAL REMARKS

Mount the CNC away from coolants, chemical products, blows, etc. which could damage it. Before turning the unit on, verify that the ground connections have been properly made.

To prevent electrical shock at the central unit of the 8055 CNC, use the proper mains AC connector at the power supply module. Use 3-wire power cables (one for ground connection).

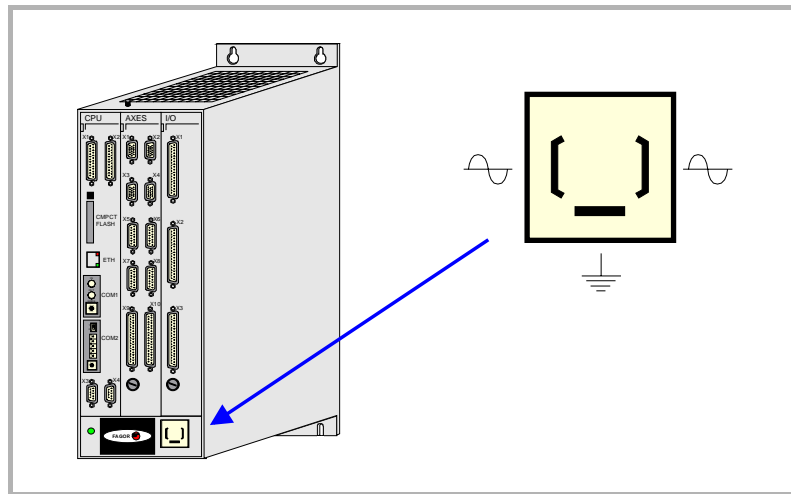

To prevent electrical shock at the monitor of the 8055 CNC, use the proper mains AC connector (A) with 3-wire power cables (one of them for ground connection).

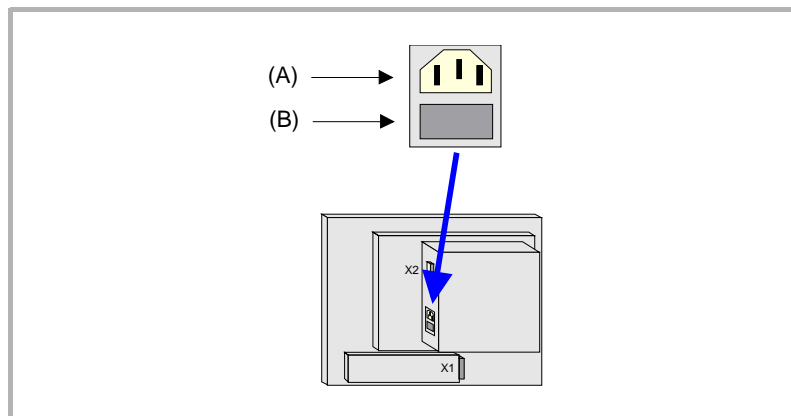

Before turning on the monitor of the 8055 CNC and verifying that the external AC line (B) fuse of each unit is the right one. See identification label of the unit itself.

In case of a malfunction or failure, disconnect it and call the technical service. Do not get into the inside of the unit.

FAGOR 

CNC 8055
CNC 8055i



Additional remarks



CNC 8055
CNC 8055i

FAGOR DOCUMENTATION

OEM manual

It is directed to the machine builder or person in charge of installing and starting-up the CNC.

USER-M manual

Directed to the end user.

It describes how to operate and program in M mode.

USER-T manual

Directed to the end user.

It describes how to operate and program in T mode.

MC Manual

Directed to the end user.

It describes how to operate and program in MC mode.

It contains a self-teaching manual.

TC Manual

Directed to the end user.

It describes how to operate and program in TC mode.

It contains a self-teaching manual.

MCO/TCO model

Directed to the end user.

It describes how to operate and program in MCO and TCO mode.

Examples-M manual

Directed to the end user.

It contains programming examples for the M mode.

Examples-T manual

Directed to the end user.

It contains programming examples for the T mode.

WINDNC Manual

It is directed to people using the optional DNC communications software.

It is supplied in a floppy disk with the application.

WINDRAW55 manual

Directed to people who use the WINDRAW55 to create screens.

It is supplied in a floppy disk with the application.



CNC 8055
CNC 8055i



Fagor documentation



CNC 8055
CNC 8055i

The CNC can be programmed both at the machine (from the front panel) or from external peripheral devices (tape reader/cassette recorder, computer, etc). Memory available to the user for carrying out the part programs is 1 Mbyte.

The part programs and the values in the tables which the CNC has can be entered from the front panel, from a pc (DNC) or from a peripheral.

Entering programs and tables from the front panel.

Once the editing mode or desired table has been selected, the CNC allows you to enter data from the keyboard.

Entering programs and tables from a Computer (DNC) or Peripheral Device.

The CNC allows data to be interchanged with a computer or peripheral device, using RS232C and RS422 cables.

If this is controlled from the CNC, it is necessary to preset the corresponding table or part program directory (utilities) you want to communicate with.

Depending on the type of communication required, the serial port machine parameter "PROTOCOL" should be set.

"PROTOCOL" = 0 if the communication is with a peripheral device.

"PROTOCOL" = 1 if the communication is via DNC.

1.1 Part programs

The operating manual describes the different operating modes. Refer to that manual for further information.

Editing a part-program

To create a part-program, access the –Edit– mode.

The new part-program edited is stored in the CNC's RAM memory. A copy of the part-programs may be stored in the "MemKey Card", at a PC connected through serial line 1 or 2 or in the hard disk.

To transmit a program to a PC through serial line 1 or 2, proceed as follows:

1. Execute the application "*Fagor50.exe*" or "*WinDNC.exe*" at the PC.
2. Activate DNC communications at the CNC.
3. Select the work directory at the CNC. It is selected from the –Utilities– mode, option Directory \Serial L \Change directory

In –Edit– mode, it is possible to modify part-programs residing in the CNC's RAM memory. To modify a program stored in the "MemKey Card", in a PC or in the hard disk, it must be previously copied into RAM memory.

Executing and editing a part-program

Part-programs stored anywhere may be executed or simulated. Simulation is carried out in the –Simulation– mode, whereas the execution is done in the –Automatic– mode.

When executing or simulating a part-program, bear in mind the following points:

- Only subroutines stored in the CNC's RAM memory can be executed. Therefore, to execute a subroutine stored in the "MemKey Card", in a PC or in the hard disk, it must be first copied into the CNC's RAM memory.
- The GOTO and RPT instructions cannot be used in programs that are executed from a PC connected through the serial lines.
- From a program in execution, another program can be executed which is in RAM memory, in the "MemKey Card", in a PC or in the hard disk using the EXEC instruction.

The user customizing programs must be in RAM memory so the CNC can execute them.

–Utilities– operating mode

The –Utilities– mode, lets display the part-program directory of all the devices, make copies, delete, rename and even set the protections for any of them.

1.

GENERAL CONCEPTS
Part programs



CNC 8055
CNC 8055i

.T. MODEL
(SOFT V16.1x)

Operations that may be carried out with part-programs.

	RAM	CARD A	HD	DNC
See the program directory of ...	Yes	Yes	Yes	Yes
See the subroutine directory of ...	Yes	No	No	No
Create the work directory from ...	No	No	No	No
Change the work directory from ...	No	No	No	Yes
Edit a program from ...	Yes	No	No	No
Modify a program from ...	Yes	No	No	No
Delete a program from ...	Yes	Yes	Yes	Yes
Copy from/to RAM memory to/from ...	Yes	Yes	Yes	Yes
Copy from/to CARD A to/from ...	Yes	Yes	Yes	Yes
Copy from/to HD to/from ...	Yes	Yes	Yes	Yes
Copy from/to DNC to/from ...	Yes	Yes	Yes	Yes
Rename a program from ...	Yes	Yes	Yes	No
Change the comment of a program from ...	Yes	Yes	Yes	No
Change the protections of a program from ...	Yes	Yes	Yes	No
Execute a part-program from ...	Yes	Yes	Yes	Yes
Execute a user program from ...	Yes	No	No	No
Execute a PLC program from ...	Yes	*	No	No
Execute programs with GOTO or RPT instructions from ...	Yes	Yes	Yes	No
Execute subroutines residing in ...	Yes	No	No	No
Execute programs with the EXEC instruction, in RAM from ...	Yes	Yes	Yes	Yes
Execute programs with the EXEC instruction, in CARD A from ...	Yes	Yes	Yes	Yes
Execute programs with the EXEC instruction, in HD from ...	Yes	Yes	Yes	Yes
Execute programs with the EXEC instruction, in DNC from ...	Yes	Yes	Yes	No
Open programs with the OPEN instruction, in RAM from ...	Yes	Yes	Yes	Yes
Open programs with the OPEN instruction, in CARD A from ...	Yes	Yes	Yes	Yes
Open programs with the OPEN instruction, in HD from ...	Yes	Yes	Yes	Yes
Open programs with the OPEN instruction, in DNC from ...	Yes	Yes	Yes	No
Via Ethernet:				
See from a PC the program directory of ...	No	No	Yes	No
See from a PC the subroutine directory of ...	No	No	No	No
See from a PC, a directory in ...	No	No	No	No

(*) If it is not in RAM memory, it generates the executable code in RAM and it executes it.

Ethernet

When having the Ethernet option and if the CNC is configured as another node within the computer network, the following operations are possible from any PC of the network:

- Access the part-program directory of the Hard Disk.
- Edit, modify, delete, rename, etc. the programs stored on the hard disk.
- Copy programs from the hard disk to the PC and vice versa.

To configure the CNC as another node within the computer network, see the installation manual.



GENERAL CONCEPTS
Part programs



**CNC 8055
CNC 8055i**

·T· MODEL
(SOFT V16.1x)

1.1.1 Considerations regarding the Ethernet connection

When configuring the CNC as another node in the computer network, the programs stored in the hard disk module (HD) may be edited and modified from any PC.

Instructions for setting up a PC to access CNC directories

To set up the PC to access the CNC directories, we recommend to proceed as follows.

1. Open the "Windows Explorer"
2. On the "Tools" menu, select the "Connect to Network Drives" option.
3. Select the drive, for example "D".
4. Indicate the path. The path will be the CNC name followed by the name of the shared directory.

For example: \\FAGORCNC\CNCHD

5. When selecting the option: "Connect again when initiating the session", the selected CNC will appear on each power-up as another path of the "Windows Explorer" without having to define it again.

Data format

This connection is established through Ethernet and, therefore, the CNC does not control the syntax of the programs while they are received or modified. However, whenever accessing the program directory of the Hard Disk (HD), the following verification takes place:

File name.

The file number must always have 6 digits and the extension PIM (for milling) or PIT (for lathe).

Examples: 001204.PIM 000100.PIM 123456.PIT 020150.PIT

If the file has been given the wrong name, for example: 1204.PIM or 100.PIT, the CNC will not change it, but it will display it with the comment "*****". The file name cannot be modified at the CNC; it must be edited from the PC to correct the error.

File size.

If the file is empty (size = 0) the CNC will display it with the comment "*****".

The file can be edited or deleted either from the CNC or from the PC.

First line of the program.

The first line of the program must have the % character, the comment associated with the file (up to 20 characters) and between the 2 commas (,) the program attributes O (OEM), H (hidden), M (modifiable), X (executable).

%Comment ,MX,
% ,OMX,

If the first line does not exist, the CNC will display the program with an empty comment and with the modifiable (M) and executable (X) attributes.

When the format of the first line is wrong, the CNC does not modify it, but it displays it with the comment "*****". The file can be edited or deleted either from the CNC or from the PC.

The format is incorrect when the comment has more than 20 characters, a comma (,) is missing to group the attributes or there is a strange character in the attributes.

1.

GENERAL CONCEPTS
Part programs



CNC 8055
CNC 8055i

.T- MODEL
(SOFT V16.1X)

1.2 DNC connection

The CNC offers as optional feature the possibility of working in DNC (Distributed Numerical Control), enabling communication between the CNC and a computer to carry out the following functions:

- Directory and delete commands.
- Transfer of programs and tables between the CNC and a computer.
- Remote control of the machine.
- The ability to supervise the status of advanced DNC systems.

1.3 Communication protocol via DNC or peripheral device

This type of communication enables program-and-table transfer commands, plus the organization of CNC directories such as the computer directory, for copying/deleting programs, etc. to be done either from the CNC or the computer.

When you want to transfer files, it is necessary to follow this protocol:

- The “%” symbol will be used to start the file, followed by the program comment (optional), of up to 20 characters.

Then, and separated by a comma “,” comes the protection of each file, read, write, etc. These protections are optional and need not be programmed.

To end the file header, RT (RETURN) or LF (LINE FEED) characters should be sent separated by a comma (“,”).

Example: %Fagor Automation, MX, RT

- Following the header, the file blocks should be programmed. These will all be programmed according to the programming rules indicated in this manual. After each block, to separate it from the others, the RT (RETURN) or LF (LINE FEED) characters should be used.

Example: N20 G90 G01 X100 Y200 F2000 LF
 (RPT N10, N20) N3 LF

If communication is made with a peripheral device, you will need to send the ‘end of file’ command. This command is selected via the machine parameter for the serial port: “EOFCHR”, and can be one of the following characters :

ESC	ESCAPE
EOT	END OF TRANSMISSION
SUB	SUBSTITUTE
EXT	END OF TRANSMISSION

1.

GENERAL CONCEPTS
DNC connection

FAGOR 

CNC 8055
CNC 8055i

·T· MODEL
(SOFT V16.1X)

1.

GENERAL CONCEPTS

Communication protocol via DNC or peripheral device



CNC 8055
CNC 8055i

.T- MODEL
(SOFT V16.1X)

A CNC program consists of a series of blocks or instructions. These blocks or instructions are made of words composed of capital letters and numerical format.

The CNC's numerical format consists of :

- The signs . (decimal points), + (plus), - (minus).
- Digits 0 1 2 3 4 5 6 7 8 9.

Programming allows spaces between letters, numbers and symbols, in addition to ignoring the numerical format if it has zero value, or a symbol if it is positive.

The numeric format of a word may be replaced by an arithmetic parameter when programming. Later on, during execution, the CNC will replace the arithmetic parameter by its value. For example, if XP3 has been programmed, during execution the CNC will replace P3 by its numerical value, obtaining results such as X20, X20.567, X-0.003, etc.

2.1 Program structure at the CNC

All the blocks which make up the program have the following structure:

Block header + program block + end of block

2.1.1 Block header

The block header is optional, and may consist of one or more block skip conditions and by the block number or label. Both must be programmed in this order.

Block skip condition. "/", "/1", "/2", "/3".

These three block skip conditions, given that "/" and "/1" are the same, they are governed by the marks BLKSKIP1, BLKSKIP2 and BLKSKIP3 of the PLC. If any of these marks is active, the CNC will not execute the block or blocks in which it has been programmed; the execution takes place in the following block.

Up to 3 skip conditions can be programmed in one block; they will be evaluated one by one, respecting the order in which they have been programmed.

The control reads 20 blocks ahead of the one being executed in order to calculate in advance the path to be run. The condition for block skip will be analyzed at the time when the block is read i.e. 20 blocks before execution.

If the block skip needs to be analyzed at the time of execution, it is necessary to interrupt the block preparation, by programming G4 in the previous block.

Label or block number. N(0-99999999).

This is used to identify the block, and is only used when block references or jumps are made. They are represented by the letter N followed by up to 8 digits (0-99999999).

No particular order is required and the numbers need not be sequential. If two or more blocks with the same label number are present in the same program, the CNC will always give priority to the first number.

Although it is not necessary to program it, by using a softkey the CNC allows the automatic programming of labels. The programmer can select the initial number and the step between labels.

Restrictions:

- Displaying the number of the active block in the top window of the screen:
 - When executing a program in ISO mode, when the label number is higher than 9999, it displays N****.
 - On the "DISPLAY / SUBROUTINES" window, when displaying an RPT that has a label higher than 9999, it displays it with ****.
- Canned cycles G66, G68 and G69 can only be edited using 4-digit labels.

2.

2.1.2 Program block

This is written with commands in ISO and high level languages. To prepare a program, blocks written in both languages will be used, although each one should be edited with commands in just one language.

ISO language.

This language is specially designed to control axis movement, as it gives information and movement conditions, in addition to data on feedrate. It offers the following types of functions.

- Preparatory functions for movement, used to determine geometry and working conditions, such as linear and circular interpolations, threading, etc.
- Control functions for axis feedrate and spindle speeds.
- Tool control functions.
- Complementary functions, with technological instructions.

High level language.

This enables access to general purpose variables and to system tables and variables.

It gives the user a number of control sentences which are similar to the terminology used in other languages, such as IF, GOTO, CALL, etc. It also allows the use of any type of expression (arithmetic, referential, or logical).

It also has instructions for the construction of loops, plus subroutines with local variables. A local variable is one that is only recognized by the subroutine in which it has been defined.

It is also possible to create libraries, grouping subroutines with useful and tested functions, which can be accessed from any program.

2.

CREATING A PROGRAM

Program structure at the CNC

FAGOR 

**CNC 8055
CNC 8055i**

·T· MODEL
(SOFT V16.1X)

2.1.3 End of block

The end of block is optional and may consist of the indication of number of repetitions of the block and of the block comment. Both must be programmed in this order.

Number of block repetitions. N(0-9999)

This indicates the number of times the block will be executed. The number of repetitions is represented by the letter N followed by up to 4 digits (0-9999). The active machining operation does not take place if N0 is programmed; only the movement programmed within the block takes place.

Movement blocks can only be repeated which, at the time of their execution, are under the influence of a modal subroutine. In these cases, the CNC executes the programmed move and the active machining operation (canned cycle or modal subroutine) the indicated number of times.

Block comment

The CNC allows you to incorporate any kind of information into all blocks in the form of a comment. The comment is programmed at the end of the block, and should begin with the character “;” (semicolon).

If a block begins with “;” all its contents will be considered as a comment, and it will not be executed.

Empty blocks are not permitted. They should contain at least one comment.

2.

CREATING A PROGRAM

Program structure at the CNC



CNC 8055
CNC 8055i

.T- MODEL
(SOFT V16.1X)

AXES AND COORDINATE SYSTEMS

3

Given that the purpose of the CNC is to control the movement and positioning of axes, it is necessary to determine the position of the point to be reached through its coordinates.

The CNC allows you to use absolute, relative or incremental coordinates throughout the same program.

3.1 Axis nomenclature

The axes are named according to DIN 66217.

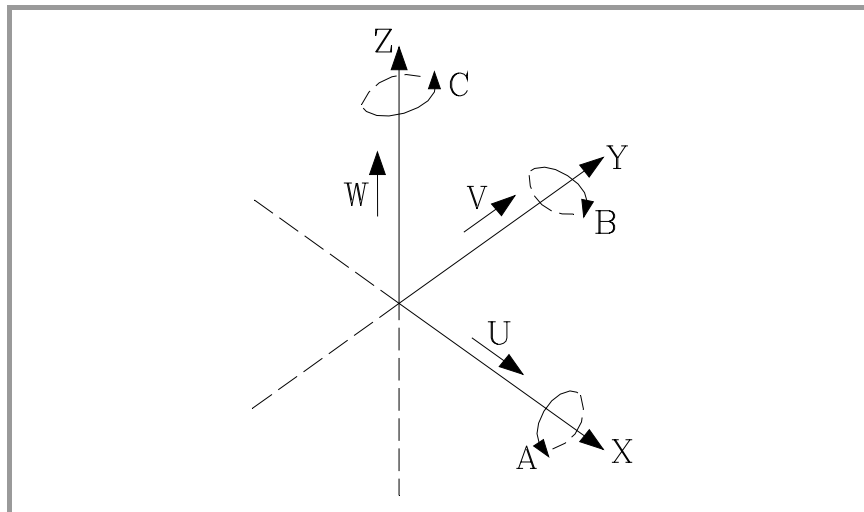

Characteristics of the system of axes:

- | | |
|---------|---|
| X and Y | main movements on the main work plane of the machine. |
| Z | parallel to the main axis of the machine, perpendicular to the main XY plane. |
| U, V, W | auxiliary axes parallel to X, Y, Z respectively. |
| A, B, C | Rotary axes on each axis X, Y, Z. |

FAGOR 

**CNC 8055
CNC 8055i**

·T· MODEL
(SOFT V16.1x)

The drawing below shows an example of the nomenclature of the axes on a parallel lathe.

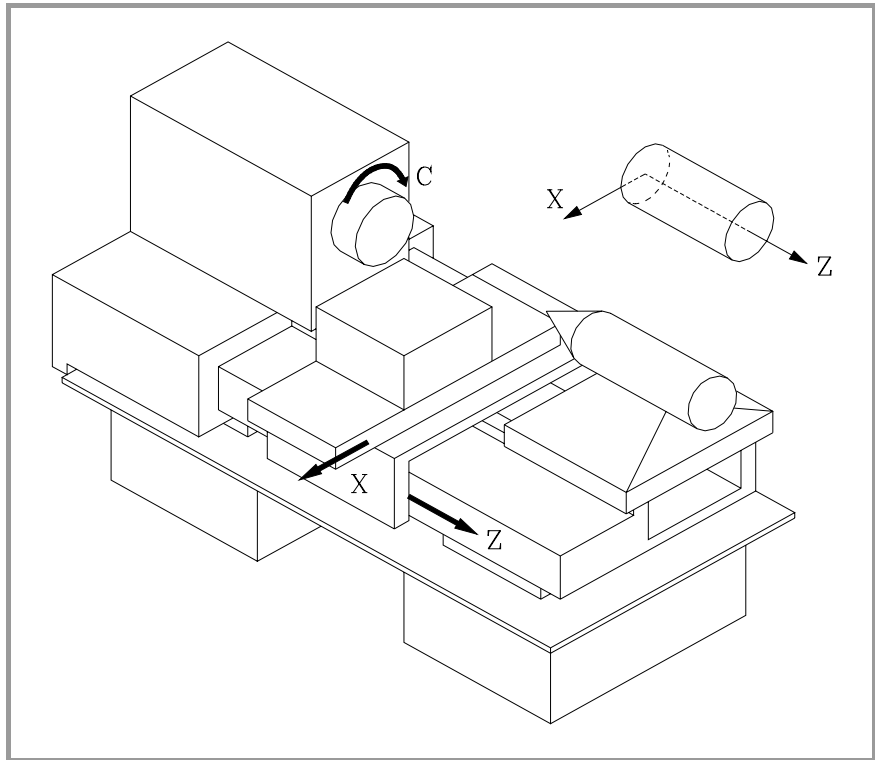

3.

AXES AND COORDINATE SYSTEMS Axis nomenclature

3.1.1 Axis selection

Of the 9 possible axes that may exist, the CNC allows the manufacturer to select up to 7 of them.

Moreover, all the axes should be suitably defined as linear/rotary, etc. through the axis machine parameters which appear in the Installation and Start-up Manual.

There is no limitation to the programming of the axes, and up to 7 axes may be interpolated at the same time.



CNC 8055
CNC 8055i

.T- MODEL
(SOFT V16.1x)

3.2 Plane selection (G16, G17, G18, G19)

Plane selection should be made when the following are carried out :

- Circular interpolations.
- Controlled corner rounding.
- Tangential entry and exit.
- Chamfer.
- Coordinate programming in Polar coordinates.
- Pattern rotation.
- Tool radius Compensation.
- Tool length compensation.

The "G" functions which enable selection of work planes are as follows :

G16 axis1 axis2. It may be used to select the desired work plane and the turning direction of G02 and G03 (circular interpolation), programming as axis1 the abscissa axis and as axis2 the ordinate axis.

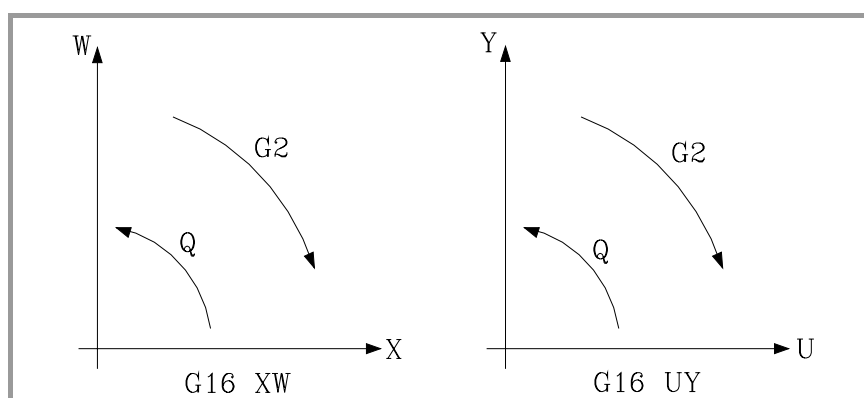

G17. Selects the XY plane

G18. Selects the ZX plane

G19. Selects the YZ plane

The G16, G17, G18 and G19 functions are modal and incompatible among themselves. The G16 function should be programmed on its own within a block.

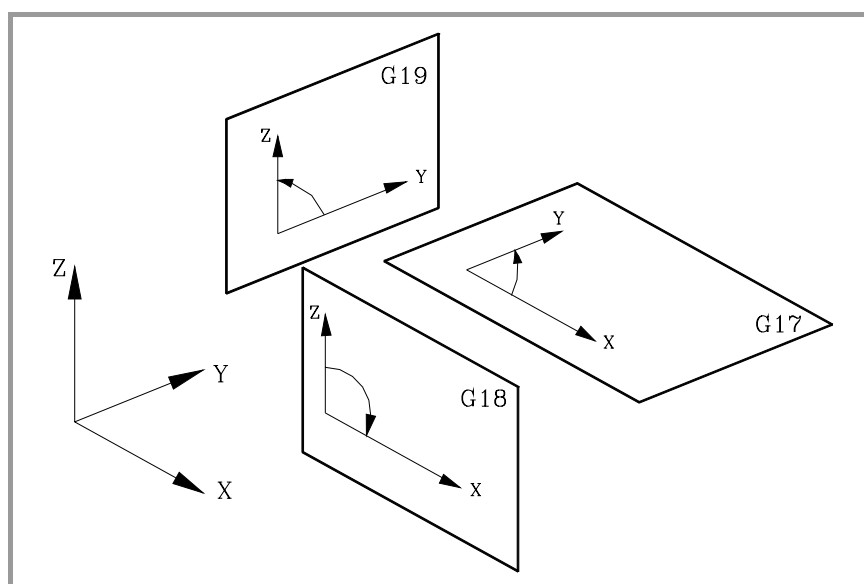

On power-up, after executing M02, M30 or after EMERGENCY or RESET, the CNC will assume that the plane defined by the general machine parameter as "IPLANE" is the work plane.

3.

AXES AND COORDINATE SYSTEMS
Plane selection (G16, G17, G18, G19)



CNC 8055
CNC 8055i

·T· MODEL
(SOFT V16.1x)

3.3 Part dimensioning. Millimeters (G71) or inches (G70)

3.

AXES AND COORDINATE SYSTEMS
Part dimensioning. Millimeters (G71) or inches (G70)

The CNC allows you to enter units of measurement with the programming, either in millimeters or inches.

It has a general machine parameter "INCHES" to define the unit of measurement of the CNC.

However, these units of measurement can be changed at any time in the program. Two functions are supplied for this purpose :

- G70. Programming in inches.
- G71. Programming in millimeters.

Depending on whether G70 or G71 has been programmed, the CNC assumes the corresponding set of units for all the blocks programmed from that moment on.

The G70 and G71 functions are modal and are incompatible.

The CNC allows you to program figures from 0.00001 to 99999.9999 with or without sign, working in millimeters (G71), called format +/-5.4, or either from 0.00001 to 3937.00787 with or without sign if the programming is done in inches (G70), called format +/-4.5.

However, and to simplify the instructions, we can say that the CNC admits +/- 5.5 format, thereby admitting +/- 5.4 in millimeters and +/- 4.5 in inches.

On power-up, after executing M02, M30 or after EMERGENCY or RESET, the CNC will assume that the system of units of measurement is the one defined by the general machine parameter "INCHES".



CNC 8055
CNC 8055i

.T- MODEL
(SOFT V16.1X)

3.4 Absolute/incremental programming (G90, G91)

The CNC allows the programming of the coordinates of one point either with absolute G90 or incremental G91 values.

When working with absolute coordinates (G90), the point coordinates refer to a point of origin of established coordinates, often the part zero (datum).

When working in incremental coordinates (G91), the numerical value programmed corresponds to the movement information for the distance to be traveled from the point where the tool is situated at that time. The sign in front shows the direction of movement.

The G90 and G91 functions are modal and are incompatible.

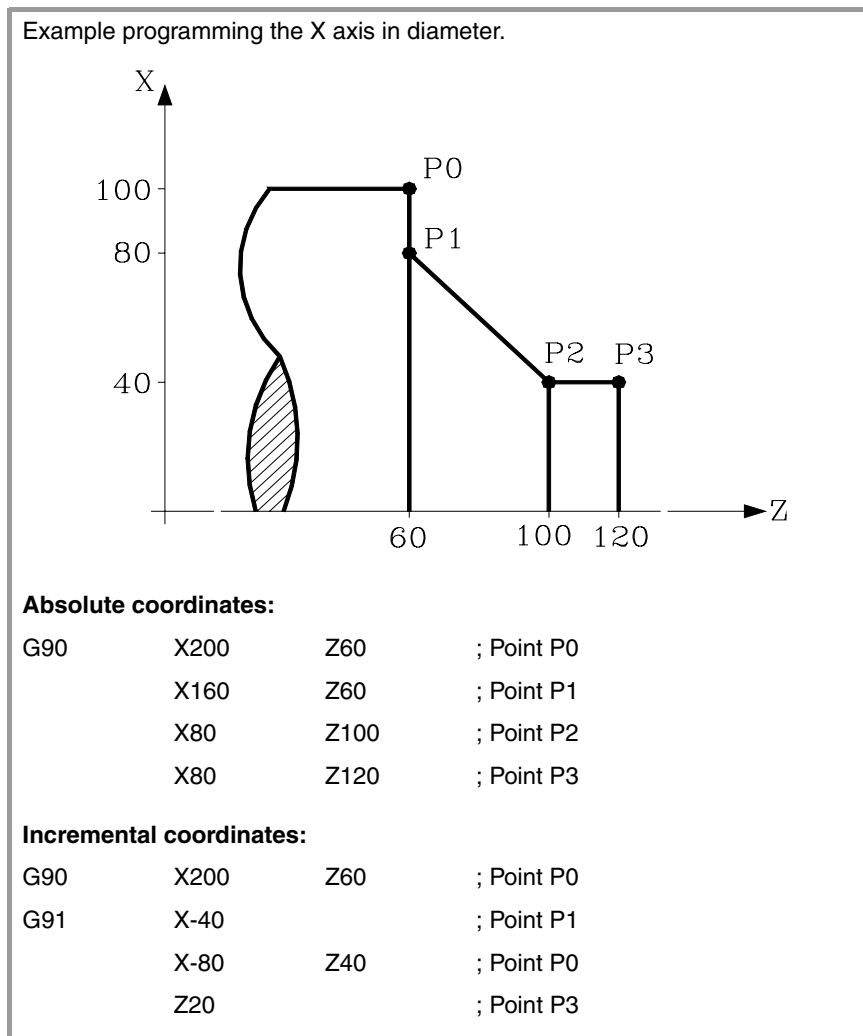

On power-up, after executing M02, M30 or after an EMERGENCY or RESET, the CNC will assume G90 or G91 according to the definition by the general machine parameter "ISYSTEM".

3.

AXES AND COORDINATE SYSTEMS
 Absolute/incremental programming (G90, G91)



CNC 8055
CNC 8055i

.T- MODEL
(SOFT V16.1X)

3.5 Programming in radius or in diameters (G152, G151)

3.

AXES AND COORDINATE SYSTEMS

Programming in radius or in diameters (G152, G151)

The X axis coordinates may be programmed in radius or diameter. The following functions may be used for that.

- G151. Programming the X axis in diameter.
- G152. Programming the X axis in radius.

It is carried out by interpolating the main spindle (that is turning) with the Z axis. After the execution of one of these functions, the CNC assumes the relevant programming mode for the blocks programmed afterwards.

The change of units is also taken into account in the following cases.

- Displaying the real X value of in the part's coordinate system.
- Reading of the variable PPOSX (programmed coordinate).

Functions G151 and G152 are modal and incompatible with each other.

On power-up, after executing an M02, M30 or after an emergency or reset, the CNC assumes G151 or G152 depending on the setting of X axis machine parameter "DFORMAT".



CNC 8055
CNC 8055i

.T- MODEL
(SOFT V16.1X)

3.6 Coordinate programming

The CNC allows the selection of up to 7 of the 9 possible axes X, Y, Z, U, V, W, A, B, C.

Each of these may be linear, linear to position only, normal rotary, rotary to position only or rotary with hirth toothing (positioning in complete degrees), according to the specification in the machine parameter of each "AXISTYPE" axis.

With the aim of always selecting the most suitable coordinate programming system, the CNC has the following types :

- Cartesian coordinates
- Polar coordinates
- Angle and Cartesian coordinate

3.6.1 Cartesian coordinates

The Cartesian Coordinate System is defined by two axes on the plane, and by three or more axes in space.

The origin of all these, which in the case of the axes X Y Z coincides with the point of intersection, is called Cartesian Origin or Zero Point of the Coordinate System.

The position of the different points of the machine is expressed in terms of the coordinates of the axes, with two, three, four, or five coordinates.

The coordinates of the axes are programmed via the letter of the axis (X, Y, Z, U, V, W, A, B, C, always in this order) followed by the coordinate value.

The values of the coordinates are absolute or incremental, depending on whether it is working in G90 or G91, and its programming format is ± 5.5 .

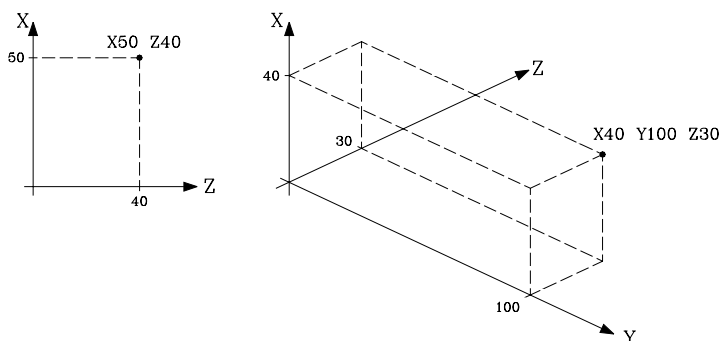

3.

AXES AND COORDINATE SYSTEMS
Coordinate programming

FAGOR 

CNC 8055
CNC 8055i

·T· MODEL
(SOFT V16.1X)

3.6.2 Polar coordinates

In the event of the presence of circular elements or angular dimensions, the coordinates of the different points on the plane (2 axes at the same time), it may be easier to express them in polar coordinates.

The reference point is called Polar Origin, and this will be the origin of the Polar Coordinate System.

A point on this system would be defined by :

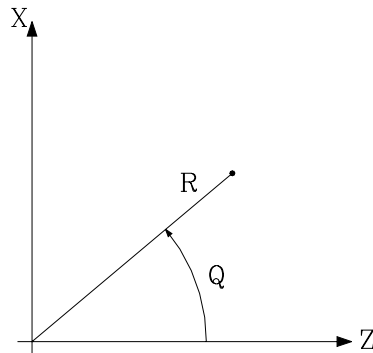

- The RADIUS (R), the distance between the polar origin and the point.
- The ANGLE (Q), formed by the abscissa axis and the line which joins the polar origin with the point. (In degrees).

The values R and Q are absolute or incremental depending on whether you are working with G90 or G91, and their programming format will be R5.5 Q±5.5. The radius value must always be positive.

The values R and Q are incremental and their programming format will be R±5.5 Q±5.5.

The R values may be negative when programming in incremental coordinates; but the resulting value assigned to the radius must always be positive.

When programming a "Q" value greater than 360°, the module will be assumed after dividing it by 360. Thus, Q420 is the same as Q60 and Q-420 is the same as Q-60.



CNC 8055
CNC 8055i

.T- MODEL
(SOFT V16.1X)

Programming example assuming that the Polar Origin is located at the Coordinate Origin.

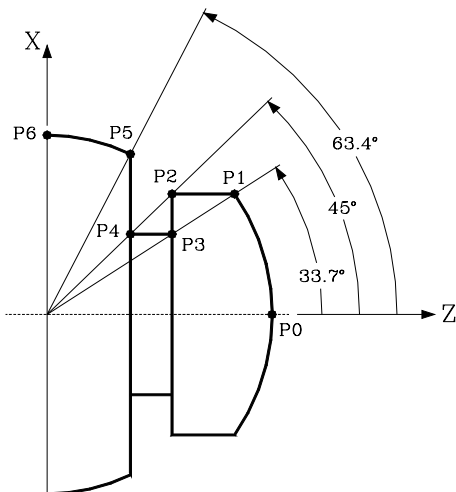

Absolute coordinates:

G90	R430	Q0	; Point P0
G03		Q33.7	; Point P1, in an arc (G03)
G01	R340	Q45	; Point P2, in a straight line (G01)
G01	R290	Q33.7	; Point P3, in a straight line (G01)
G01	R230	Q45	; Point P4, in a straight line (G01)
G01	R360	Q63.4	; Point P5, in a straight line (G01)
G03		Q90	; Point P6, in arc (G03)

Incremental coordinates:

G90	R430	Q0	; Point 0
G91 G03		Q33.7	; Point P1, in an arc (G03)
G01	R-90	Q11.3	; Point P2, in a straight line (G01)
G01	R-50	Q-11.3	; Point P3, in a straight line (G01)
G01	R-60	Q11.3	; Point P4, in a straight line (G01)
G01	R130	Q18.4	; Point P5, in a straight line (G01)
G03		Q26.6	; Point P6, in arc (G03)

The polar origin, apart from being able to be preset using function G93 (described later) can be modified in the following cases :

- On power-up, after executing M02, M30 EMERGENCY or RESET, the CNC will assume, as the polar origin, the coordinate origin of the work plane defined by the general machine parameter "IPLANE".
- Every time the work plane is changed (G16,G17,G18 or G19), the CNC assumes the coordinate origin of the new work plane selected as the polar origin.
- When executing a circular interpolation (G02 or G03), and if the general machine parameter "PORGMOVE" has a value of 1, the center of the arc will become the new polar origin.

3.

AXES AND COORDINATE SYSTEMS
Coordinate programming



CNC 8055
CNC 8055i

·T· MODEL
(SOFT V16.1X)

3.6.3 Angle and Cartesian coordinate

A point on the main plane can be defined via one of its cartesian coordinates, and the exit angle of the previous path.

Example programming the X axis in radius.

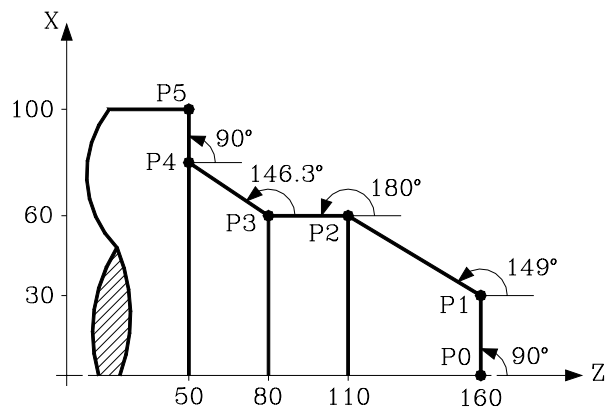

```

X0      Z160      ; Point P0
Q90     X30       ; Point P1
Q149    Z110     ; Point P2
Q180    Z80      ; Point P3
Q146.3  Z50      ; Point P4
Q90     X100     ; Point P0
    
```

If you wish to represent a point in space, the remaining coordinates can be programmed in Cartesian coordinates.

3.

AXES AND COORDINATE SYSTEMS
 Coordinate programming



CNC 8055
CNC 8055i

.T- MODEL
(SOFT V16.1x)

3.7 Rotary axes

The types of rotary axes available are:

- Normal rotary axis.
- Positioning-only rotary axis.
- Rotary HIRTH axis.

Each one of them can be divided into:

- Rollover When it is displayed between 0° and 360° .
- Non Rollover When it may be displayed between -99999° and 99999° .

They are all programmed in degrees. Therefore, their readings are not affected by the inch/mm conversion.

Normal rotary axes

They can interpolate with linear axes.

Movement: In G00 and G01.

Rollover axis programming:

- G90 The sign indicates the turning direction and the target position (between 0 and 359.9999).
- G91 The sign indicates the turning direction. If the programmed movement exceeds 360° , the axis will rotate more than one turn before positioning at the desired point.

Non-rollover axis programming.

In G90 and G91 like a linear axis.

Positioning-only rotary axis

They cannot be interpolated with linear axes.

Movement: Always in G00 and they do not admit tool radius compensation (G41, G42).

Rollover axis programming:

- G90 Always positive and in the shortest direction. End coordinate between 0 and 359.9999.
- G91 The sign indicates the turning direction. If the programmed movement exceeds 360° , the axis will rotate more than one turn before positioning at the desired point.

Non-rollover axis programming.

In G90 and G91 like a linear axis.

Rotary Hirth axis

They work like the positioning-only axis except that they do not admit decimal position values (coordinates).

More than one hirth axis can be used, but they can only be moved one at a time.

3.

AXES AND COORDINATE SYSTEMS
Rotary axes

FAGOR 

CNC 8055
CNC 8055i

.T- MODEL
(SOFT V16.1X)

3.8 Work zones

The CNC provides four work zones or areas, and also limits the tool movement in each of these.

3.8.1 Definition of the work zones

Within each work zone, the CNC allows you to limit the movement of the tool on each axis, with upper and lower limits being defined in each axis.

G20: Defines the lower limits in the desired zone.

G21: Defines the upper limits in the desired zone.

The format to program these functions is:

```
G20 K X...C±5.5
```

```
G21 K X...C±5.5
```

Where:

K Indicates the work zone you wish to define (1, 2, 3 or 4).

X...C Indicates the coordinates (upper or lower) with which you wish to limit the axes. These coordinates are given in radius and must be programmed with reference to machine zero (home).

It is not necessary to program all the axes, so only defined axes will be limited.

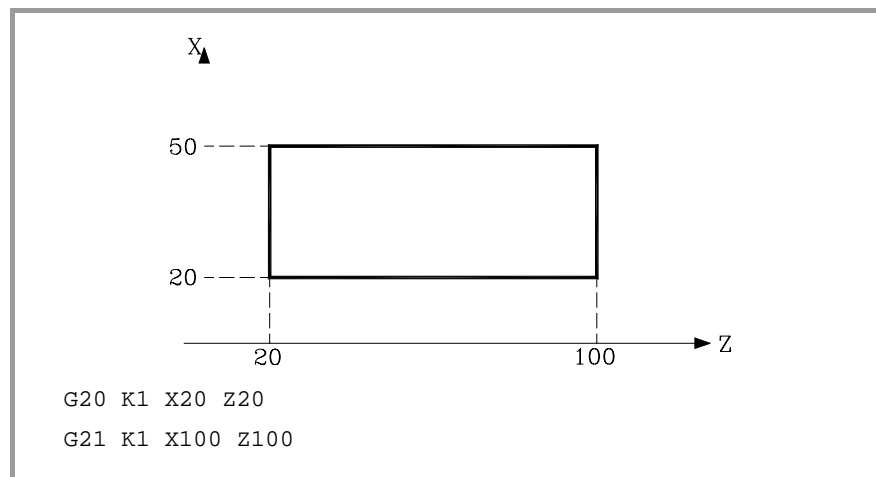

3.

AXES AND COORDINATE SYSTEMS
Work zones



CNC 8055
CNC 8055i

.T- MODEL
(SOFT V16.1x)

3.8.2 Using the work zones

Within each work zone, the CNC allows you to restrict the movement of the tool, either prohibiting its exit from the programmed zone (no exit zone) or its entry into the programmed zone (no entry zone).

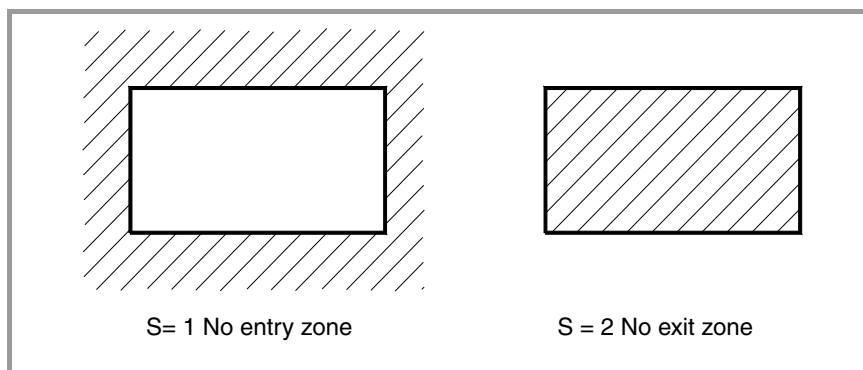

The CNC will take the dimensions of the tool into account at all times (tool offset table) to avoid it exceeding the programmed limits.

The presetting of work zones is done via Function G22, the programming format being:

```
G22 K S
```

Where:

K Indicates the work zone you wish to define (1, 2, 3 or 4).

S Indicates the enabling/disabling of the work zone.

S=0 disabled.

S=1 enabled as a no-entry zone.

S=2 enabled as a no-exit zone.

On power-up, the CNC will disable all work zones. However, upper and lower limits for these zones will not undergo any variation, and they can be re-enabled through the G22 function.

3.

AXES AND COORDINATE SYSTEMS
Work zones

FAGOR 

CNC 8055
CNC 8055i

·T· MODEL
(SOFT V16.1X)

3.

AXES AND COORDINATE SYSTEMS

Work zones



CNC 8055
CNC 8055i

.T- MODEL
(SOFT V16.1X)

4.1 Reference points

A CNC machine needs the following origin and reference points defined :

- Machine Reference Zero or home. This is set by the manufacturer as the origin of the coordinate system of the machine.
- Part zero or point of origin of the part. This is the origin point that is set for programming the measurements of the part. It can be freely selected by the programmer, and its machine reference zero can be set by the zero offset.
- Machine Reference point. This is a point on the machine established by the manufacturer around which the synchronization of the system is done. The control positions the axis on this point, instead of moving it as far as the Machine Reference Zero, taking, at this point, the reference coordinates which are defined via the axis machine parameter "REFVALUE".

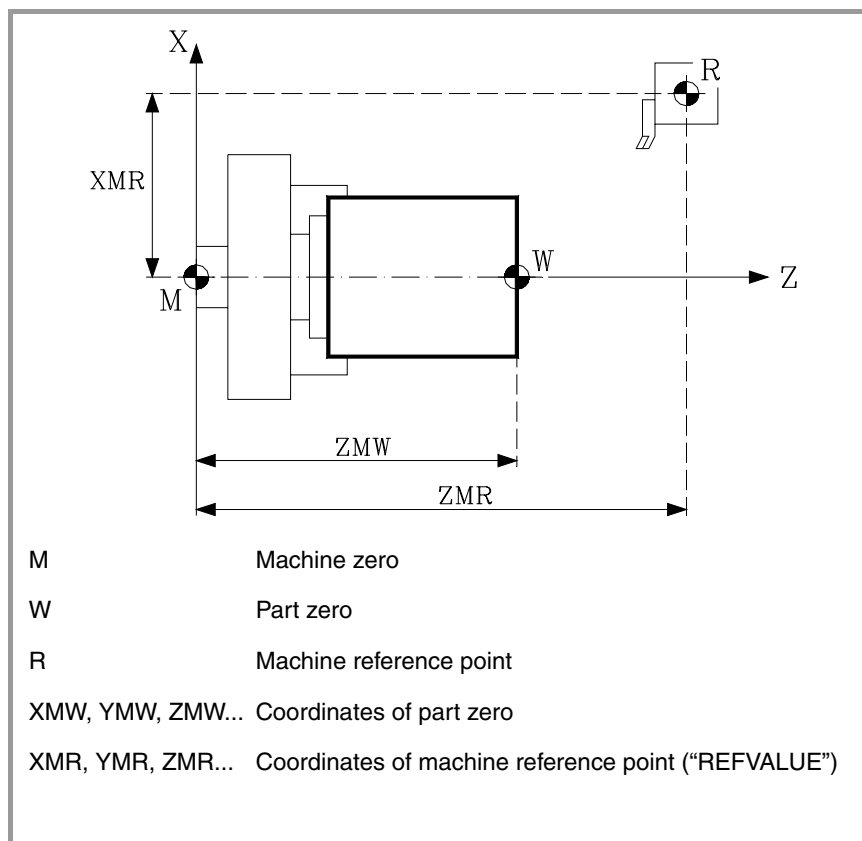

4.2 Machine reference (Home) search (G74)

4.

REFERENCE SYSTEMS

Machine reference (Home) search (G74)

The CNC allows you to program the machine reference search in two ways :

- Machine reference (home) search of one or more axes in a particular order.

G74 is programmed followed by the axes in which you want to carry out the reference search. For example: G74 X Z.

The CNC begins the movement of all the selected axes which have a machine reference switch (machine axis parameter “DECINPUT”) and in the direction indicated by the axis machine parameter “REFDIREC”.

This movement is carried out at the feedrate indicated by the axis machine parameter “REFEED1” for each axis until the home switch is hit.

Next, the home search (marker pulse or home) will be carried out in the programmed order.

This second movement will be carried out one axis at a time, at the feedrate indicated in the axis machine parameter “REFEED2” until the machine reference point is reached (i.e. the marker pulse is found).

- Home search using the associated subroutine.

The G74 function will be programmed alone in the block, and the CNC will automatically execute the subroutine whose number appears in the general machine parameter “REFPSUB”. In this subroutine it is possible to program the machine reference searches required, and also in the required order.

In a block in which G74 has been programmed, no other preparatory function may appear.

If the machine reference search is done in JOG mode, the part zero selected is lost. The coordinates of the reference point indicated in the machine axis parameter “REFVALUE” is displayed. In all other cases, the active part zero will be maintained and the CNC will display the position values with respect to that part zero.

If the G74 command is executed in MDI, the display of coordinates depends on the mode in which it is executed : Jog, Execution, or Simulation.



CNC 8055
CNC 8055i

.T- MODEL
(SOFT V16.1x)

4.3 Programming with respect to machine zero (G53)

Function G53 can be added to any block that has path control functions.

It is only used when the programming of block coordinates relating to machine zero is required. These coordinates should be expressed in millimeters or inches, depending on how the general machine parameter "INCHES" is defined.

By programming G53 alone (without motion information) the current active zero offset is canceled regardless of whether it was originated by a G54-G59 or a G92 preset. This origin preset is described next.

Function G53 is not modal, so it should be programmed every time you wish to indicate the coordinates referred to machine zero.

This function temporarily cancels radius and tool length compensation.

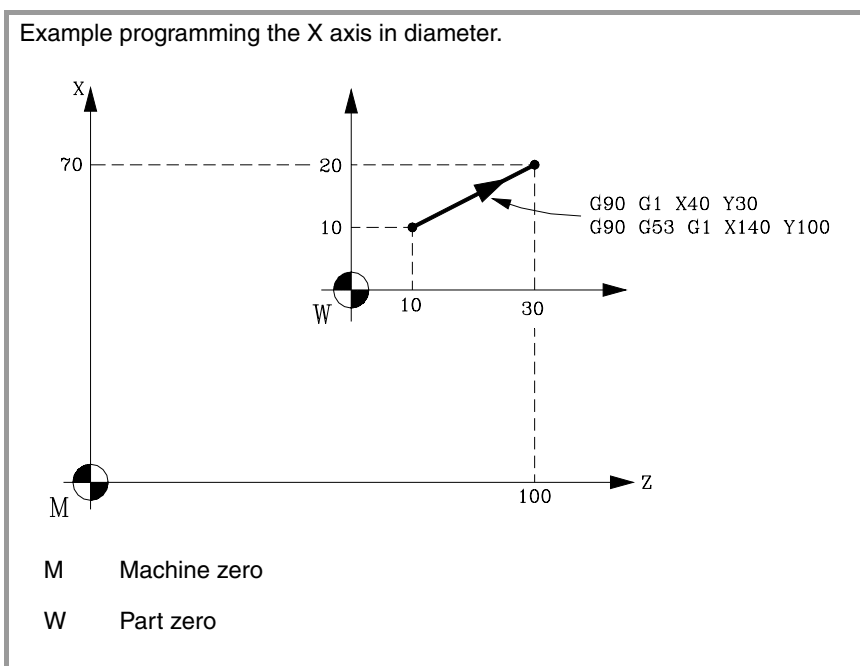

4.

REFERENCE SYSTEMS
Programming with respect to machine zero (G53)



CNC 8055
CNC 8055i

·T· MODEL
(SOFT V16.1X)

4.4 Coordinate preset and zero offsets

The CNC allows you to carry out zero offsets with the aim of using coordinates related to the plane of the part, without having to modify the coordinates of the different points of the part at the time of programming.

The zero offset is defined as the distance between the part zero (point of origin of the part) and the machine zero (point of origin of the machine).

4.

REFERENCE SYSTEMS
 Coordinate preset and zero offsets

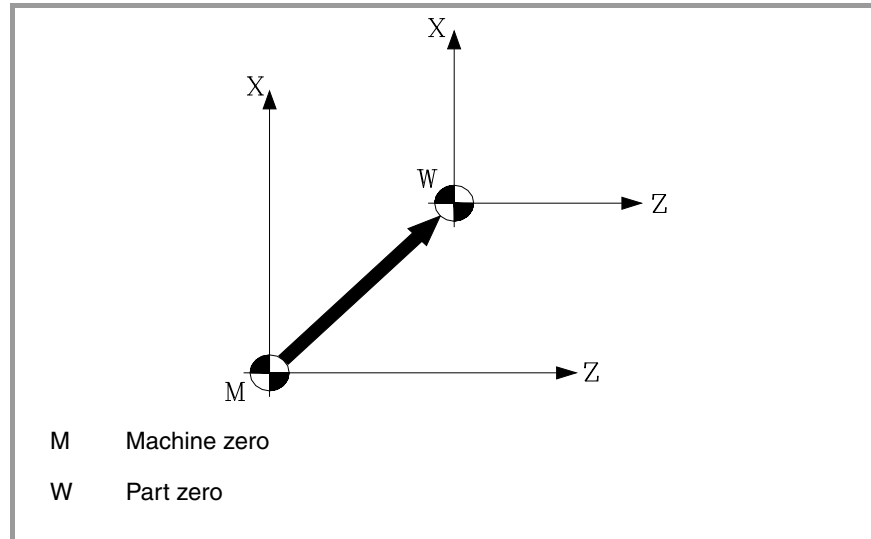

This zero offset can be carried out in one of two ways :

- Via Function G92 (coordinate preset). The CNC accepts the coordinates of the programmed axes after G92 as new axis values.
- Via the use of zero offsets (G54 ... G59, G159N1 ... G159N20); the CNC accepts as a new part zero the point located relative to machine zero at the distance indicated by the selected table(s).

Both functions are modal and incompatible, so if one is selected the other is disabled.

There is, moreover, another zero offset which is governed by the PLC. This offset is always added to the zero offset selected and is used (among other things) to correct deviations produced as a result of expansion, etc.

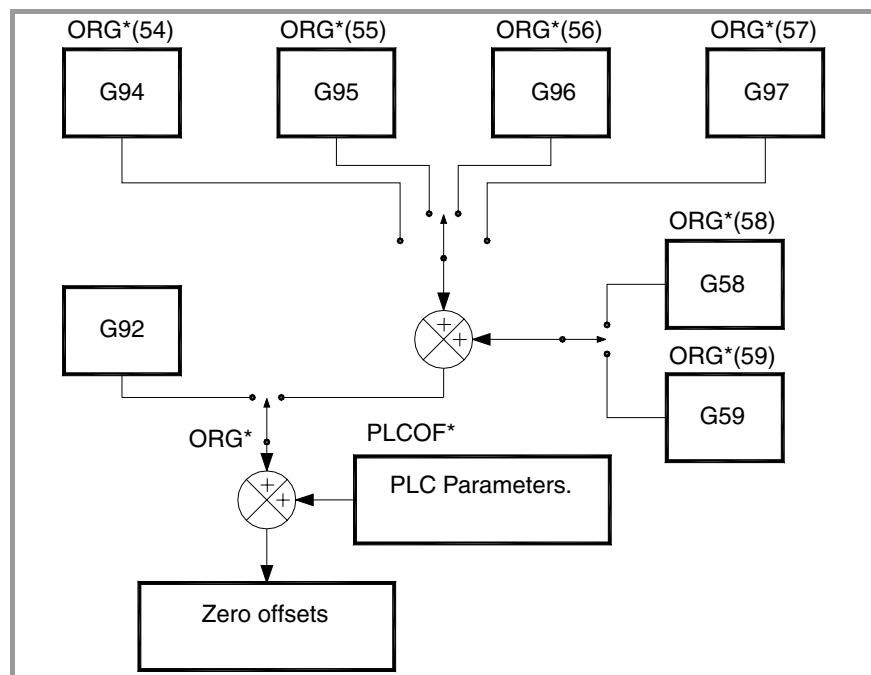

CNC 8055
CNC 8055i

.T. MODEL
(SOFT V16.1x)

4.4.1 Coordinate preset and S value limitation (G92)

Via Function G92 one can select any value in the axes of the CNC, in addition to limiting the spindle speed.

- Coordinate preset.

When carrying out a zero offset via Function G92, the CNC assumes the coordinates of the axes programmed after G92 as new axis values.

No other function can be programmed in the block where G92 is defined, the programming format being :

G92 X...C ±5.5

The values assigned to the axes are programmed in either radius or diameter depending on the setting of axis machine parameter "DFORMAT".

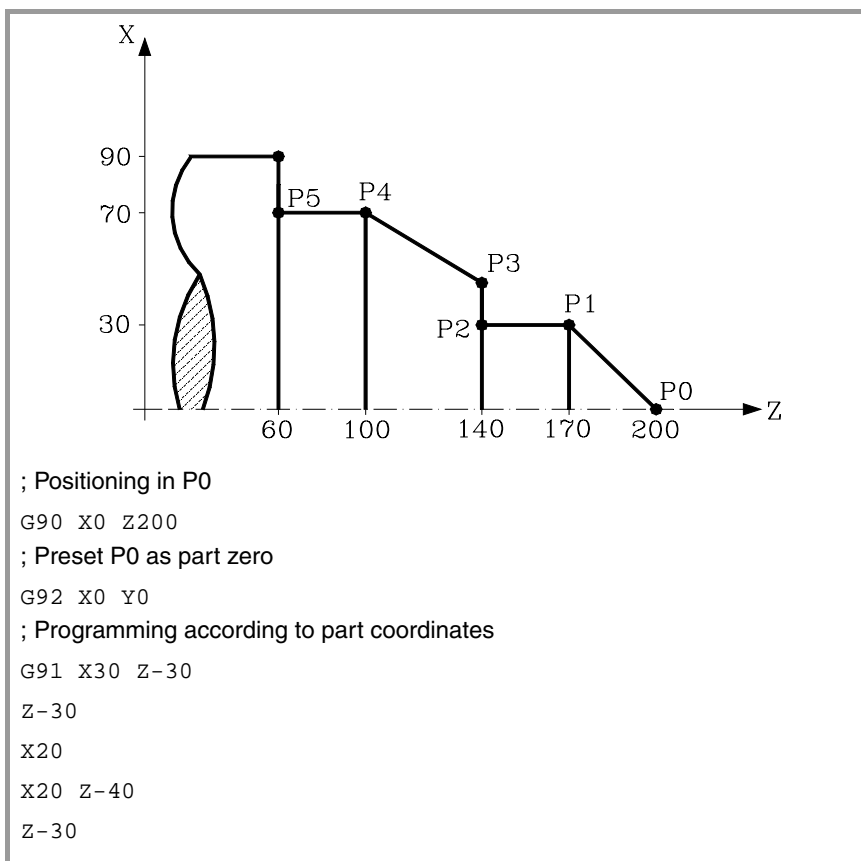

- Spindle speed limitation

Programming "G92 S5.4", the CNC limits the spindle speed to the value set by S5.4.

This means that the CNC will not accept, from that block on, the programming of S values higher than the maximum defined. Neither is it possible to exceed this maximum value from the keyboard on the front panel.

4.

REFERENCE SYSTEMS
Coordinate preset and zero offsets



CNC 8055
CNC 8055i

·T· MODEL
(SOFT V16.1X)

4.4.2 Zero offsets (G54..G59 and G159)

The CNC has a table of zero offsets, in which several zero offsets can be selected. The aim is to generate certain part zeros independently of the part zero active at the time. The table values are given in radius.

Access to the table can be obtained from the front panel of the CNC (as explained in the Operating Manual), or via the program using high-level language commands.

There are two kinds of zero offsets :

- Absolute zero offsets (G54 ... G57, G159N1 ... G159N20), which must be referred to machine zero.
- Incremental zero offsets (G58,G59).

Functions G54, G55, G56, G57, G58 & G59 must be programmed alone in the block, and work in the following way:

When one of the G54, G55, G56, G57 functions is executed, the CNC applies the zero offset programmed with respect to machine zero, canceling the possible active zero offsets.

If one of the incremental offsets G58 or G59 is executed, the CNC adds its values to the absolute zero offset active at the time. Previously canceling the additive offset which might be active.

You can see (in the following example) the zero offsets which are applied when the program is executed.

G54	Applies zero offsets G54	==> G54
G58	Applies zero offsets G58	==> G54+G58
G59	Cancels G58 and adds G59	==> G54+G59
G55	Cancels whatever and applies G55	==> G55

Once a Zero Offset has been selected, it will remain active until another one is selected or until a home search is carried out (G74) in JOG mode. This zero offset will remain active even after powering the CNC off and back on.

This kind of zero offsets established by program is very useful for repeated machining operations at different machine positions.

Example: The zero offset table is initialized with the following values:

G54:	X0	Z330
G55:	X0	Z240
G56:	X0	Z150
G58:	X0	Z-900
G59:	X0	Z-180

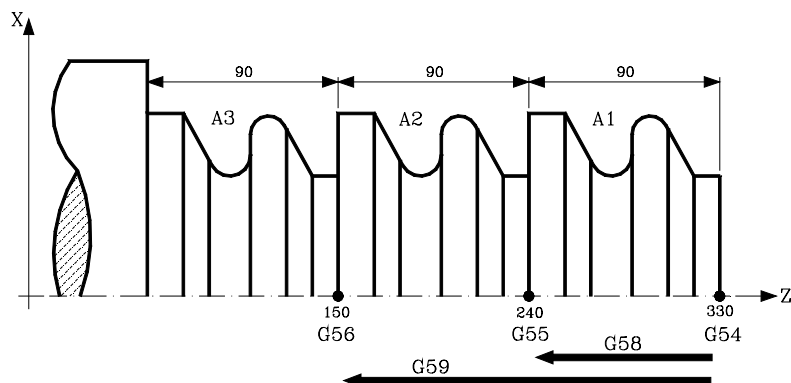

CNC 8055
CNC 8055i

.T. MODEL
(SOFT V16.1x)

Using absolute zero offsets:

G54	; Applies G54 offset
Profile execution	; Executes profile A1
G55	; Applies G55 offset
Profile execution	; Executes profile A2
G56	; Applies G56 offset
Profile execution	; Executes profile A3

Using incremental zero offsets:

G54	; Applies G54 offset
Profile execution	; Executes profile A1
G58	; Applies offsets G54+G58
Profile execution	; Executes profile A2
G59	; Applies offsets G54+G59
Profile execution	; Executes profile A3

Function G159

To apply any zero offset defined in the table.

The first six zero offsets are the same as programming G54 through G59, except that the values of G58 and G59 are absolute. This is because function G159 cancels functions G54 through G57 and, consequently, there is no active zero offset to add the G58 or G59 to.

Function G159 is programmed as follows:

G159 Nn where n is a number from 1 to 20 that indicates the number of the zero offset being applied.

Function G159 is modal, it is programmed alone in the block and is incompatible with functions G53, G54, G55, G56, G57, G58, G59 and G92.

On power-up, the CNC assumes the zero offset that was active when the CNC was turned off. On the other hand, the zero offset is neither affected by functions M02 and M30 nor by RESET.

This function is displayed in the history like G159Nn where the n is the active zero offset.

Examples:

G159 N1	It applies the first zero offset. It is the same as programming G54.
G159 N6	It applies the sixth zero offset. It is the same as programming G59, but it is applied in absolute.
G159 N20	It applies the 20th zero offset.

4.

REFERENCE SYSTEMS

Coordinate preset and zero offsets



CNC 8055
CNC 8055i

.T- MODEL
(SOFT V16.1X)

4.5 Polar origin preset (G93)

Function G93 allows you to preset any point from the work plane as a new origin of polar coordinates.

This function must be programmed alone in the block, its programming format being :

```
G93 I±5.5 J±5.5
```

Parameters I & J respectively define the abscissa and ordinate axes, of the new origin of polar coordinates referred to part zero.

The values assigned to those parameters are programmed in either radius or diameter depending on the setting of axis machine parameter "DFORMAT".

4.

REFERENCE SYSTEMS
Polar origin preset (G93)

Example programming the X axis in diameter.

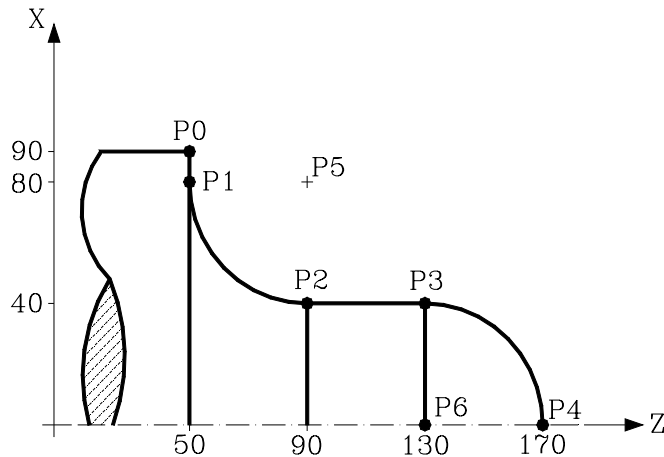

```
G90 X180 Z50 ; Point P0.
G01 X160 ; Point P1, in a straight line (G01).
G93 I90 J160 ; Presets P5 as Polar origin.
G03 Q270 ; Point P2, in an arc (G03).
G01 Z130 ; Point P3, in a straight line (G01).
G93 I130 J0 ; Presets P6 as Polar origin.
G02 Q0 ; Point P4, in an arc (G02).
```

If G93 is only programmed in a block, the point where the machine is at that moment becomes the polar origin.

On power-up; or after executing M02, M30; or after an EMERGENCY or RESET; the CNC assumes the currently active part zero as polar origin.

When selecting a new work plane (G16, G17, G18, G19), the CNC assumes as polar origin the part zero of that plane.



The CNC does not modify the polar origin when defining a new part zero; but it modifies the values of the variables: "PORGF" y "PORGS".

If, while selecting the general machine parameter "PORGMOVE" a circular interpolation is programmed (G02 or G03), the CNC assumes the center of the arc as the new polar origin.



CNC 8055
CNC 8055i

.T- MODEL
(SOFT V16.1x)

A block programmed in ISO language can consist of:

- Preparatory (G) functions
- Axis coordinates (X...C)
- Feedrate (F)
- Spindle speed (S)
- Tool number (T)
- Tool offset number (D)
- Auxiliary functions (M)

This order should be maintained within each block, although it is not necessary for every block to contain the information.

The CNC allows you to program figures from 0.00001 to 99999.9999 with or without sign, working in millimeters (G71), called format +/-5.4, or either from 0.00001 to 3937.00787 with or without sign if the programming is done in inches (G70), called format +/-4.5.

However, and to simplify the instructions, we can say that the CNC admits +/- 5.5 format, thereby admitting +/- 5.4 in millimeters and +/- 4.5 in inches.

Any function with parameters can also be programmed in a block, apart from the number of the label or block. Thus, when the block is executed the CNC substitutes the arithmetic parameter for its value at that time.

5.1 Preparatory functions

Preparatory functions are programmed using the letter G followed by up to 3 digits (G0 - G319).

They are always programmed at the beginning of the body of the block and are useful in determining the geometry and working condition of the CNC.

Table of G functions used in the CNC.

Function	M	D	V	Meaning	Section
G00	*	?	*	Rapid traverse	6.1
G01	*	?	*	Linear interpolation	6.2
G02	*		*	Clockwise circular interpolation	6.3
G03	*		*	Counterclockwise circular interpolation	6.3
G04				Dwell/interruption of block preparation	7.1 / 7.2
G05	*	?	*	Round corner	7.3.2
G06			*	Circle center in absolute coordinates	6.4
G07	*	?		Square corner	7.3.1
G08			*	Arc tangent to previous path.	6.5
G09			*	Arc defined by three points	6.6
G10	*	*		Mirror image cancellation	7.5
G11	*		*	Mirror image on X axis	7.5
G12	*		*	Mirror image on Y axis	7.5
G13	*		*	Mirror image on Z axis	7.5
G14	*		*	Mirror image in the programmed directions	7.5
G15	*		*	"C" axis	6.15
G16	*		*	Main plane selection by two addresses	3.2
G17	*	?	*	Main plane X-Y and longitudinal Z	3.2
G18	*	?	*	Main plane Z-X and longitudinal Y	3.2
G19	*		*	Main plane Y-Z and longitudinal X	3.2
G20				Definition of lower work zone limits	3.8.1
G21				Definition of upper work zone limits.	3.8.1
G22			*	Enable/disable work zones.	3.8.2
G28	*		*	It selects the second spindle or toggles (swaps) axes	5.4 / 7.8
G29	*	*		It selects the main spindle or toggles (swaps) axes	5.4 / 7.8
G30	*		*	Spindle synchronization (offset)	5.5
G32	*		*	Feedrate "F" as an inverted function of time.	6.17
G33	*		*	Electronic threading	6.12
G34				Variable-pitch threading	6.14
G36			*	Controlled corner rounding	6.10
G37			*	Tangential entry	6.8
G38			*	Tangential exit	6.9
G39			*	Chamfer	6.11
G40	*	*		Cancellation of tool radius compensation	8.2.6
G41	*		*	Left-hand tool radius compensation	8.2.3
G41 N	*		*	Collision detection	8.3
G42	*		*	Right-hand tool radius compensation	8.2.3
G42 N	*		*	Collision detection	8.3
G45	*		*	Tangential control (G45)	6.18
G50	*		*	Controlled corner rounding	7.3.3
G51	*		*	Look-Ahead	7.4
G52			*	Movement until making contact	6.16
G53			*	Programming with respect to machine zero	4.3
G54	*		*	Absolute zero offset 1	4.4.2
G55	*		*	Absolute zero offset 2	4.4.2
G56	*		*	Absolute zero offset 3	4.4.2
G57	*		*	Absolute zero offset 4	4.4.2
G58	*		*	Additive zero offset 1	4.4.2
G59	*		*	Additive zero offset 2	4.4.2
G60			*	Face drilling / tapping canned cycle.	9.13
G61			*	Drilling / tapping canned cycle on the side of the part.	9.14

5.

ISO CODE PROGRAMMING
Preparatory functions



CNC 8055
CNC 8055i

.T- MODEL
(SOFT V16.1X)

Function	M	D	V	Meaning	Section
G62			*	Slot milling canned cycle on the side of the part	9.15
G63			*	Slot milling canned cycle on the face of the part	9.16
G66			*	Pattern repeat cycle canned cycle	9.1
G68			*	X axis roughing canned cycle	9.2
G69			*	Z axis roughing canned cycle	9.3
G70	*	?	*	Programming in inches	3.3
G71	*	?	*	Programming in millimeters	3.3
G72	*		*	General and specific scaling factor	7.6
G74			*	Home search	4.2
G75			*	Probing move until touching	10.1
G76			*	Probing move while touching	10.1
G77	*		*	Axis coupling (slaving)	7.7.1
G77S	*		*	Spindle synchronization	5.5
G78	*	*	*	Cancellation of axis coupling (slaving)	7.7.2
G78S	*	*	*	Cancellation of spindle synchronization	5.5
G81			*	Turning canned cycle for straight sections	9.4
G82			*	Facing canned cycle for straight sections	9.5
G83			*	Drilling canned cycle	9.6
G84			*	Turning canned cycle for curved sections	9.7
G85			*	Facing canned cycle for curved sections	9.8
G86			*	Longitudinal threading canned cycle	9.9
G87			*	Face threading canned cycle	9.10
G88			*	X axis grooving canned cycle	9.11
G89			*	Z axis grooving canned cycle	9.12
G90	*	?	*	Absolute programming:	3.4
G91	*	?	*	Incremental programming	3.4
G92				Coordinate preset / spindle speed limit	4.4.1
G93				Polar origin preset	4.5
G94	*	?	*	Feedrate in millimeters (inches) per minute	5.2.1
G95	*	?	*	Feedrate in millimeters (inches) per revolution.	5.2.2
G96	*		*	Constant surface speed	5.3.1
G97	*	*	*	Spindle speed in RPM	5.3.2
G145	*		*	Temporary cancellation of tangential control	6.19
G151	*	?	*	Programming the X axis in diameter.	3.5
G152	*	?	*	Programming the X axis in radius.	3.5
G159	*		*	Absolute zero offsets	4.4.2
G233	*		*	Withdrawal of axes when interrupting a threading operation.	6.13

M means modal, i.e. the G function, once programmed, remains active while another incompatible G function is not programmed or until an M02, M30, EMERGENCY or RESET is executed or the CNC is turned off and back on.

D means BY DEFAULT, i.e. they will be assumed by the CNC when it is powered on, after executing M02, M30 or after EMERGENCY or RESET.

In those cases indicated by ? , it should be understood that the DEFAULT of these G functions depends on the setting of the general machine parameters of the CNC.

V means that the G code is displayed next to the current machining conditions in the execution and simulation modes.

5.

ISO CODE PROGRAMMING
Preparatory functions



CNC 8055
CNC 8055i

·T· MODEL
(SOFT V16.1X)

5.2 Feedrate F

The machining feedrate can be selected from the program. It remains active until another feedrate is programmed. It is represented by the letter F and Depending on whether it is working in G94 or G95, it is programmed in mm/minute (inches/minute) or in mm/revolution (inches/revolution).

Its programming format is 5.5; in other words, 5.4 when programmed in mm and 4.5 when programmed in inches.

The maximum operating feedrate of the machine, limited on each axis by the axis machine parameter "MAXFEED", may be programmed via code F0, or by giving F the corresponding value.

The programmed feedrate F is effective working in linear (G01) or circular (G02, G03) interpolation. If function F is not programmed, the CNC assumes the feedrate to be F0. When working in rapid travel (G00), the machine will move at the rapid feedrate indicated by the axis machine parameter "G00FEED", apart from the F programmed.

The programmed feedrate F may be varied between 0% and 255% via the PLC, or by DNC, or between 0% and 120% via the switch located on the Operator Panel of the CNC.

The CNC, however, is equipped with the general machine parameter "MAXFOVR" to limit maximum feedrate variation.

If you are working in rapid travel (G00), rapid feedrate will be fixed at 100%, alternatively it can be varied between 0% and 100%, depending on how the machine parameter "RAPIDOVR" is set.

When functions G33 (electronic threading), G34 (variable-pitch threading), G86 (longitudinal threading canned cycle) or G87 (face threading canned cycle) are executed the feedrate cannot be modified; it works at 100% of programmed F.

5.

ISO CODE PROGRAMMING
Feedrate F



CNC 8055
CNC 8055i

.T- MODEL
(SOFT V16.1x)

5.2.1 Feedrate in mm/min or inches/min (G94)

From the moment the code G94 is programmed, the control takes that the feedrates programmed through F5.5 are in mm/min or inches/mm.

If the moving axis is rotary, the CNC interprets that the programmed feedrate is in degrees/minute.

If an interpolation is made between a rotary and a linear axis, the programmed feedrate is taken in mm/min or inches/min, and the movement of the rotary axis (programmed in degrees) will be considered programmed in millimeters or inches.

The relationship between the feedrate of the axis component and the programmed feedrate "F" is the same as that between the movement of the axis and the resulting programmed movement.

$$\text{Feedrate component} = \frac{\text{Feedrate F x Movement of axis}}{\text{Resulting programmed movement}}$$

Example:

On a machine that has linear X and Z axes and rotary C axis, all located at point X0 Z0 C0, the following movement is programmed:

```
G1 G90 X100 Z20 C270 F10000
```

You get:

$$F_x = \frac{F \cdot \Delta x}{\sqrt{(\Delta x)^2 + (\Delta z)^2 + (\Delta c)^2}} = \frac{10000 \times 100}{\sqrt{100^2 + 20^2 + 270^2}} = 3464,7946$$

$$F_z = \frac{F \cdot \Delta z}{\sqrt{(\Delta x)^2 + (\Delta z)^2 + (\Delta c)^2}} = \frac{10000 \times 20}{\sqrt{100^2 + 20^2 + 270^2}} = 692,9589$$

$$F_c = \frac{F \cdot \Delta c}{\sqrt{(\Delta x)^2 + (\Delta z)^2 + (\Delta c)^2}} = \frac{10000 \times 270}{\sqrt{100^2 + 20^2 + 270^2}} = 9354,9455$$

Function G94 is modal i.e. once programmed it stays active until G95 is programmed.

On power-up, after executing M02, M30 or following EMERGENCY or RESET, the CNC assumes function G94 or G95 according to how the general machine parameter "IFEED" is set.

5.

ISO CODE PROGRAMMING

Feedrate F



CNC 8055
CNC 8055i

·T· MODEL
(SOFT V16.1X)

5.2.2 Feedrate in mm/rev.or inches/rev (G95)

From the moment when the code G95 is programmed, the control assumes that the feedrates programmed through F5.5 are in mm/rev or inches/mm.

This function does not affect the rapid moves (G00) which will be made in mm/min or inch/min. By the same token, it will not be applied to moves made in the JOG mode, during tool inspection, etc.

Function G95 is modal i.e. once programmed it stays active until G94 is programmed.

On power-up, after executing M02, M30 or following EMERGENCY or RESET, the CNC assumes function G94 or G95 according to how the general machine parameter "IFEED" is set.

Jogging in G95

If the axis to be jogged does not belong to the active plane, the movement is carried out in mm/minute; thus, it is not necessary to program an S at the spindle.

Also, if any axis of the plane is the Y axis, it is not necessary either to program the S for jog movements in any axis, regardless of whether it belongs to the plane or not.

This is especially interesting for auxiliary axes, center rests and tailstocks, because, in those cases, the S has no effect.

5.

ISO CODE PROGRAMMING Feedrate F



CNC 8055
CNC 8055i

.T. MODEL
(SOFT V16.1x)

5.3 Spindle speed (S)

The turning speed of the spindle is programmed directly in rpm via code S5.4 (G97) or in m/min (ft/min when working in inches) when in constant surface speed mode (G96).

The maximum value is limited by spindle machine parameters "MAXGEAR1", "MAXGEAR2", "MAXGEAR3" and "MAXGEAR4", in each case depending on the spindle range selected.

It is also possible to limit this maximum value from the program by using function G92 S5.4.

The programmed turning speed S may be varied from the PLC, DNC, or by the SPINDLE keys "+" and "-" on the Operator Panel of the CNC.

This speed variation is made between the maximum and minimum values established by spindle machine parameters "MINSOVR" and "MAXSOVR".

The incremental pitch associated with the SPINDLE keys "+" and "-" on the CNC Operator Panel in order to vary the programmed S value is fixed by the spindle machine parameter "SOVRSTEP".

When functions G33 (electronic threading), G34 (variable-pitch threading), G86 (longitudinal threading canned cycle) or G87 (face threading canned cycle) are executed the programmed speed cannot be modified; it works at 100% of programmed S.

5.3.1 Constant surface speed (G96)

When programming G96, the CNC assumes that the spindle speed programmed with S5.4 is in m/min or ft/min and the lathe starts working in constant surface speed mode.

It is recommended to program the spindle speed S5.4 in the same block where G96 is programmed; the corresponding spindle gear (M41, M42, M43, M44) must be selected in the same block or in a previous one.

If no spindle speed is programmed in the block containing the G96, the CNC assumes as spindle speed the last one used in constant surface speed mode.

If no spindle speed is programmed and there is no previous one or the corresponding spindle gear is not selected, the CNC will show the corresponding error message.

Function G96 is modal i.e. once programmed it stays active until G97 is programmed.

On power-up, after executing M02, M30 or following EMERGENCY or RESET, the CNC assumes function G97.

5.3.2 Spindle speed in rpm (G97)

When programming G97, the CNC assumes that the spindle speed programmed with S5.4 is in rpm.

If no spindle speed S5.4 is programmed in the block containing the G97, the CNC assumes as programmed speed at which the spindle was turning at the time.

Function G97 is modal i.e. once programmed it stays active until G96 is programmed.

On power-up, after executing M02, M30 or following EMERGENCY or RESET, the CNC assumes function G97.

5.

ISO CODE PROGRAMMING

Spindle speed (S)

FAGOR
CNC 8055
CNC 8055i

 ·T· MODEL
 (SOFT V16.1X)

5.4 Spindle selection (G28, G29)

The lathe model can have two spindles: main and second. They both can be operative simultaneously, but only one can be controlled at a time.

This selection is made using functions G28 and G29.

G28: Second spindle selection.

G29: Main spindle selection.

Once the desired spindle has been selected, it can be acted upon from the keyboard or by means of the following functions:

M3, M4, M5, M19

S****

G33, G34, G94, G95, G96, G97

Both spindles can work in open and closed loop. Only the main spindle can work as a C axis.

Functions G28 and G29 are modal and incompatible with each other.

Function G28 and G29 must be programmed alone in the block.

No more information can be programmed in that block. On power-up, after executing an M02, M30 or after an EMERGENCY or RESET, the CNC assumes function G29 (selects the main spindle).

Operating example for when 2 spindles are used.

On power-up, the CNC assumes function G29 selecting the main spindle.

All the keyboard actions and by spindle related functions affect the main spindle.

Example: S1000 M3

Main spindle clockwise at 1000 rpm.

To select the second spindle, execute function G28.

From then on, All the keyboard actions and spindle related functions affect the second spindle.

The main spindle remains in its previous status.

Example: S1500 M4

Second spindle turns counterclockwise at 1500 rpm.

The main spindle keeps turning at 1000 rpm.

To select the main spindle again, execute function G29.

From then on, all the keyboard actions and spindle related functions affect the main spindle.

The second spindle stays in its previous status.

Example: S2000

The main spindle keeps turning clockwise but at 2000 rpm.

The second spindle keeps turning at 1500 rpm.

5.

ISO CODE PROGRAMMING
Spindle selection (G28, G29)



CNC 8055
CNC 8055i

.T- MODEL
(SOFT V16.1x)

5.5 Synchronized spindles (G30, G77S, G78S)

With function G77S, two spindles (main and secondary) may be synchronized in speed; this synchronism may be cancelled with function G78S. Always program G77S and G78S because functions G77, G78 to slave and unslave the axes.

When the spindles are synchronized in speed, the second one turns at the same speed as the main spindle.

Function G77S may be executed at any time, open loop (M3, M4) or closed loop (M19), the spindles may even have different ranges (gears).

General output "SYNSPEED (M5560)" will be high while the spindle are in synch (same speed).

When this synchronism is cancelled (G78S), the second spindle recovers its previous speed and status (M3, M4, M5, M19) and the main spindle stays in the current status.

If while in synchronism, an S is programmed greater than the maximum allowed, the CNC applies the maximum value while they are synchronized. When canceling this synchronism, the limit is no longer applied and the main spindle assumes the programmed speed.

While the spindles are synchronized in speed, function G77S active, with G30 they may also be synchronized in position and set an angular offset between them so the second spindle follows the main spindle at this set offset distance.

Programming format: G30 D ±359.9999 (offset in degrees)

For example, with G30 D90 the second spindle will turn 90° behind the main spindle.

Considerations

Before activating the synchronism, both spindles must be homed (referenced).

The spindles cannot be synchronized if the XC or ZC (C axis) plane is selected.

To synchronized the spindles in position (G30) they must be synchronized in speed already (G77S).

To synchronize two spindles, the SERVOSON and SERVOSO2 signals must be activated already. While the spindles are synchronized, only the signals of the main spindle will be attended to PLCCNTL, SPDLINH, SPDLREV, etc. On the other hand, when making a thread, only the feedback and reference pulses of the main spindle will be taken into account.

While the spindle synchronism is active, it is possible to:

- Execute functions G94, G95, G96, G97, M3, M4, M5, M19 S***.
- Change the spindle speed via DNC, PLC or CNC (S).
- Change the spindle speed override via DNC, PLC, CNC or keyboard.
- Change the spindle speed limit via DNC, PLC or CNC (G92 S)

But the following cannot be done:

- Toggle the spindles: G28, G29.
- Change gears: M41, M42, M43, M44.
- Define the XC or ZC plane in "C" axis mode.

5.

ISO CODE PROGRAMMING
Synchronized spindles (G30, G77S, G78S)

FAGOR 

**CNC 8055
CNC 8055i**

·T· MODEL
(SOFT V16.1X)

5.6 Tool number (T) and tool offset (D)

With the "T" function, it is possible to select the tool and with the "D" function it is possible to select the offset associated with it. When defining both parameters, the programming order is T D. For example: T6 D17

5.

ISO CODE PROGRAMMING
Tool number (T) and tool offset (D)

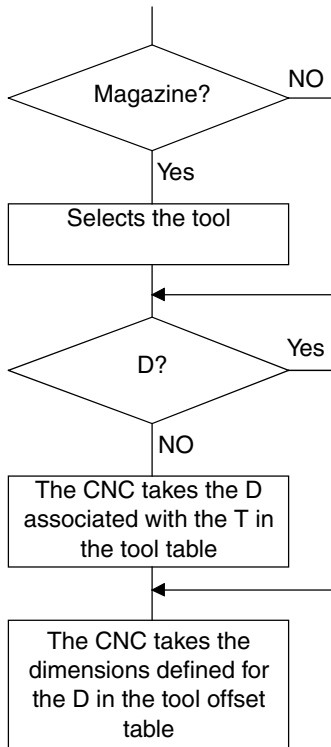

If the machine has a tool magazine, the CNC looks up the "Tool magazine table" to know the position occupied by the selected tool and the desired one.

If the "D" function has not be defined, it looks up the "Tool table" to know the "D" offset associated with it.

It looks up the "tool offset table" and assumes the tool dimensions corresponding to the "D" offset. Analyzes the "tool geometry" to know the geometry of the cutter (width, angle and cutting angle). The "Geometry table" is associated with the "T" or with the "D" according to the manufacturer's criteria, general machine parameter "GEOMTYPE (P123)"

To access, check and define these tables, refer to the operating manual.

How to use the T and D functions

- The "T" and "D" functions may be programmed alone or together as shown in the following example:

T5 D18 Selects tool 5 and assumes the dimensions of tool offset 18

D22 Tool 5 stays selected and it assumes the dimensions of tool offset 22.

T3 Selects tool 3 and assumes the dimensions of the offset associated with that tool.

- When using a tool holding turret, more tools are normally used than the available turret positions. Thus, the same turret position must be used by several tools.

In these cases, the "T" and "D" functions must be programmed.

The "T" function refers to the turret position and the "D" function to the dimensions of the tool located in that position.

Thus, for example, programming T5 D23 means selecting the turret position 5 and assuming the geometry and dimensions of tool offset 23.

- When having a tool holding arm with two cutters, the "T" and "D" functions must also be programmed.

The "T" function refers to the arm and the "D" function to the dimensions of the cutter. Thus, one may program T1 D1 or T1 D2 depending on which of the two cutters are to be used.



CNC 8055
CNC 8055i

.T- MODEL
(SOFT V16.1X)

Tool length and radius compensation.

The CNC looks up the "tool offset table" and assumes the tool dimensions corresponding to the active "D" offset.

Tool length compensation is applied all the time, whereas tool radius compensation must be selected by the user by means of functions G40, G41 and G42.

If there is no tool selected or D0 is defined, neither tool length nor radius compensation is applied.

For further information, refer to chapter 8 "tool compensation" in this manual..

5.**ISO CODE PROGRAMMING**

Tool number (T) and tool offset (D)

FAGOR **CNC 8055
CNC 8055i**·T· MODEL
(SOFT V16.1X)

5.7 Auxiliary function (M)

The miscellaneous functions are programmed by means of the M4 Code, it being possible to program up to 7 functions in the same block.

When more than one function has been programmed in one block, the CNC executes these correlatively to the order in which they have been programmed.

The CNC is provided with an M functions table with "NMISCFUN" (general machine parameter) components, specifying for each element:

- The number (0-9999) of the defined miscellaneous M function.
- The number of the subroutine which is required to associate to this miscellaneous function.
- An indicator which determines if the M function is executed before or after the movement block in which it is programmed.
- An indicator which determines if the execution of the M function interrupts block preparation or not.
- An indicator which determines if the M function is executed or not, after the execution of the associated subroutine.
- An indicator which determines if the CNC must wait for the signal AUX END or not (Executed M signal, coming from the PLC), to continue the execution of the program.

If, when executing the M miscellaneous function, this is not defined in the M functions table, the programmed function will be executed at the beginning of the block and the CNC will wait for the AUX END to continue the execution of the program.

Some of the miscellaneous functions are assigned an internal meaning in the CNC.

If, while executing the associated subroutine of an "M" miscellaneous function, there is a block containing the same "M", this will be executed but not the associated subroutine.



All the miscellaneous "M" functions which have an associated subroutine must be programmed alone in a block.

In the case of functions M41 through M44 with associated subroutine, the S that generates the gear change must be programmed alone in the block. Otherwise, the CNC will display error 1031.

5.7.1 M00. Program stop

When the CNC reads code M00 in a block, it interrupts the program. To start up again, press CYCLE START.

We recommend that you set this function in the table of M functions, in such a way that it is executed at the end of the block in which it is programmed.

5.7.2 M01. Conditional program stop

This is identical to M00, except that the CNC only takes notice of it if the signal M01 STOP from the PLC is active (high logic level).

5.7.3 M02. End of program

This code indicates the end of program and carries out a "General Reset" function of the CNC (returning it to original state). It also carries out the M05 function.

We recommend that you set this function in the table of M functions, in such a way that it is executed at the end of the block in which it is programmed.

5.7.4 M30. End of program with return to the first block

Identical to M02 except that the CNC returns to the first block of the program.

5.7.5 M03 Clockwise spindle rotation

This code represents clockwise spindle start.

We recommend that you set this function in the table of M functions, so that it is executed at the beginning of the block in which it is programmed.

5.7.6 M04. Counterclockwise spindle rotation

This code represents counterclockwise spindle start. We recommend that you set this function in the table of M functions, so that it is executed at the beginning of the block in which it is programmed.

5.7.7 M05. Spindle stop

We recommend that you set this function in the table of M functions, in such a way that it is executed at the end of the block in which it is programmed.

5.

ISO CODE PROGRAMMING
Auxiliary function (M)

FAGOR 

CNC 8055
CNC 8055i

·T· MODEL
(SOFT V16.1X)

5.7.8 M06. Tool change code

If the general machine parameter "TOFFM06" (indicating that it is a machining center) is active, the CNC sends instructions to the tool changer and updates the table corresponding to the tool magazine.

It is recommended to set this function in the table of M functions, so that the subroutine corresponding to the tool changer installed in the machine is executed.

5.

5.7.9 M19. Spindle orientation

With this CNC it is possible to work with the spindle in open loop (M3, M4) and with the spindle in closed loop (M19).

In order to work in closed loop, it is necessary to have a rotary encoder installed on the spindle of the machine.

To switch from open loop to closed loop, execute function M19 or M19 S±5.5. The CNC will act as follows:

- If the spindle has a home switch, the CNC modifies the spindle speed until it reaches the one set by spindle machine parameter "REFEED1".

It then searches for actual marker pulse (I_o) of the spindle encoder at the turning speed set by spindle machine parameter REFEED2.

And, finally, it positions the spindle at the programmed S±5.5 point.

- If the spindle does not have a home switch, it searches the encoder marker pulse at the turning speed set by spindle machine parameter REFEED2.

And, then, it positions the spindle at the programmed S±5.5 point.

If only M19 is executed, the spindle is oriented to position "S0" after having "found" the home switch.

To, now, orient the spindle to another position, program M19 S±5.5, the CNC will not perform the home search since it is already in closed loop and it will orient the spindle to the indicated position. (S±5.5).

The S±5.5 code indicates the spindle position, in degrees, from the spindle reference point (marker pulse).

The sign indicates the counting direction and the 5.5 value is always considered to be absolute coordinates regardless of the type of units currently selected.

Example:

S1000 M3

Spindle in open loop.

M19 S100

The spindle switches to closed loop. Home search and positioning (orientation) at 100°.

M19 S -30

The spindle orients to -30°, passing through 0°.

M19 S400

The spindle turns a whole revolution and positions at 40°.



CNC 8055
CNC 8055i

5.7.10 M41, M42, M43, M44. Spindle gear change

The CNC offers 4 spindle speed ranges M41, M42, M43 and M44 with maximum speed limits set by the spindle machine parameters "MAXGEAR1", "MAXGEAR2", "MAXGEAR3" and "MAXGEAR4".

If machine parameter "AUTOGEAR" is set so the CNC executes the range change automatically, M41 thru M44 will be sent out automatically by the CNC without having to be programmed.

If this machine parameter is set for non-automatic gear change, M41 thru M44 will have to be programmed every time a gear change is required. Bear in mind that the maximum voltage value assigned to machine parameter "MAXVOLT" corresponds to the maximum speed indicated for each one of the speed ranges (machine parameters "MAXGEAR1" thru "MAXGEAR4").

Regardless of whether the gear change is automatic or not, functions M41 through M44 may have an associated subroutine. If the function M41 through M44 is programmed and then an S corresponding to that gear, it does not generate the automatic gear change and it does not execute the associated subroutine.

5.7.11 M45. Auxiliary spindle / Live tool

In order to use this miscellaneous function, it is necessary to set one of the axes of the machine as auxiliary spindle or live tool (general machine parameter P0 thru P7).

To use the auxiliary spindle or live tool, execute the command: M45 S±5.5 where S indicates the turning speed in rpm and the sign indicates the turning direction.

The CNC will output the analog voltage corresponding to the selected speed according to the value assigned to the machine parameter "MAXSPEED" for the auxiliary spindle.

To stop the auxiliary spindle, program M45 or M45 S0.

Whenever the auxiliary spindle or live tool is active, the CNC will let the PLC know by activating the general logic output "DM45" (M5548).

Also, it is possible to set the machine parameter for the auxiliary spindle "SPDLOVR" so the Override keys of the front panel can modify the currently active turning speed of the auxiliary spindle.

5.

ISO CODE PROGRAMMING

Auxiliary function (M)

FAGOR
CNC 8055
CNC 8055i

 ·T· MODEL
 (SOFT V16.1x)

5.

ISO CODE PROGRAMMING Auxiliary function (M)



CNC 8055
CNC 8055i

.T- MODEL
(SOFT V16.1X)

The CNC allows you to program movements on one axis only or several at the same time.

Only those axes which intervene in the required movement are programmed. The programming order of the axes is as follows :

X, Y, Z, U, V, W, A, B, C

The coordinates of each axis are programmed in either radius or diameter depending on the setting of axis machine parameter "DFORMAT".

6.1 Rapid traverse (G00)

The movements programmed after G00 are executed at the rapid feedrate indicated in the axis machine parameter "G00FEED".

Independently of the number of axis which move, the resulting path is always a straight line between the starting point and the final point.

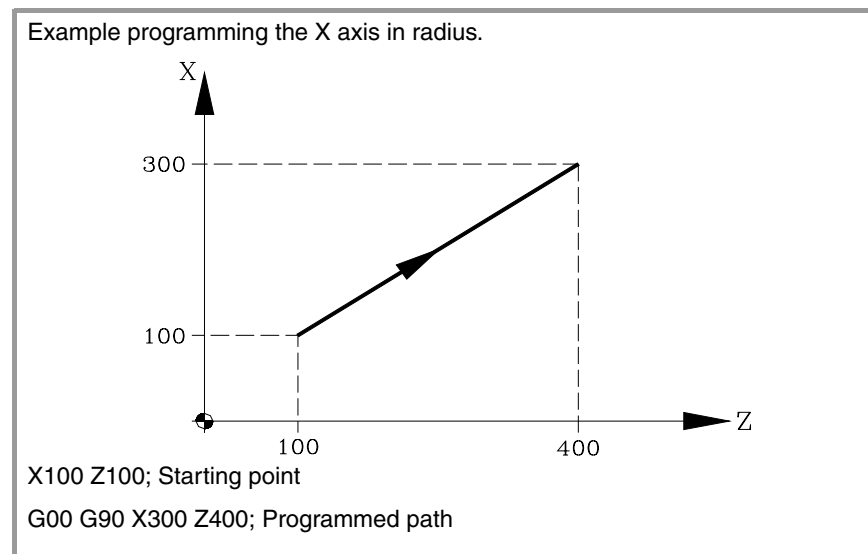

It is possible, via the general machine parameter "RAPIDOVR", to establish if the feedrate override % switch (when working in G00) operates from 0% to 100%, or whether it stays constant at 100%.

When G00 is programmed, the last "F" programmed is not cancelled i.e. when G01, G02 or G03 are programmed again "F" is recovered.

G00 is modal and incompatible with G01, G02, G03, G33 G34 and G75. Function G00 can be programmed as G or G0.

On power-up, after executing M02, M30 or after EMERGENCY or RESET, the CNC assumes code G00 or G01, depending on how general machine parameter "IMOVE" has been set.

6.2 Linear interpolation (G01)

The movements programmed after G01 are executed according to a straight line and at the programmed feedrate "F".

When two or three axes move simultaneously the resulting path is a straight line between the starting point and the final point.

The machine moves according to this path to the programmed feedrate "F". The CNC calculates the feedrates of each axis so that the resulting path is the "F" value programmed.

6.

PATH CONTROL
Linear interpolation (G01)

Example programming the X axis in diameter.

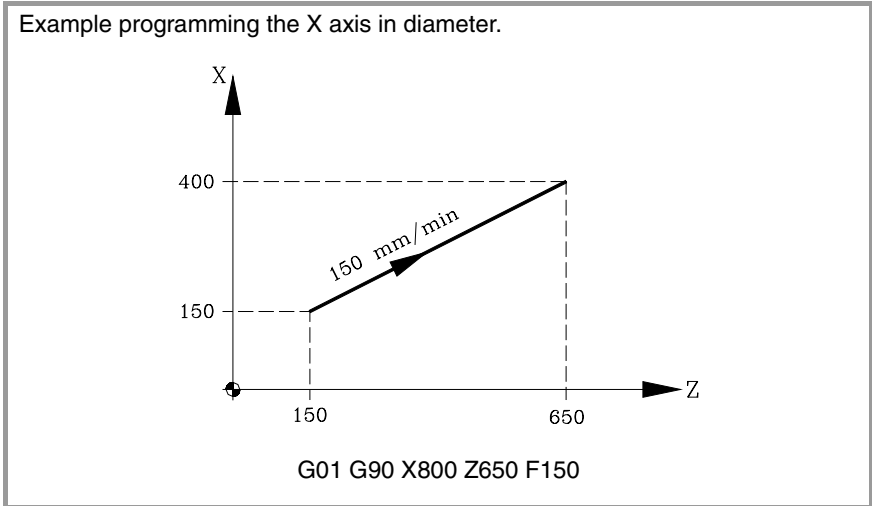

The programmed feedrate "F" may vary between 0% and 120% via the switch located on the Control Panel of the CNC, or by selecting between 0% and 255% from the PLC, or via the DNC or the program.

The CNC, however, is equipped with the general machine parameter "MAXFOVR" to limit maximum feedrate variation.

With this CNC, it is possible to program a positioning-only axis in a linear interpolation block. The CNC will calculate the feedrate for this positioning-only axis so it reaches the target coordinate at the same time as the interpolating axes.

Function G01 is modal and incompatible with G00, G02, G03, G33 and G34. Function G01 can be programmed as G1.

On power-up, after executing M02, M30 or after EMERGENCY or RESET, the CNC assumes code G00 or G01, depending on how general machine parameter "IMOVE" has been set.



CNC 8055
CNC 8055i

.T- MODEL
(SOFT V16.1x)

6.3 Circular interpolation (G02, G03)

There are two ways of carrying out circular interpolation:

- G02: Clockwise circular interpolation
- G03: Counterclockwise circular interpolation

Movements programmed after G02 and G03 are executed in the form of a circular path and at the programmed feedrate "F".

The following example shows the direction of G02 and G03 on different machines. Observe how the relative tool position is maintained with respect to the axes.

- Horizontal lathes:

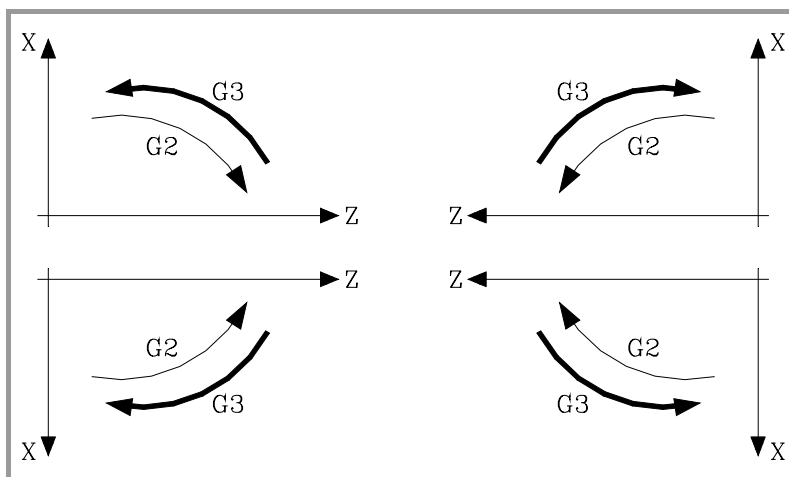

- Vertical lathes:

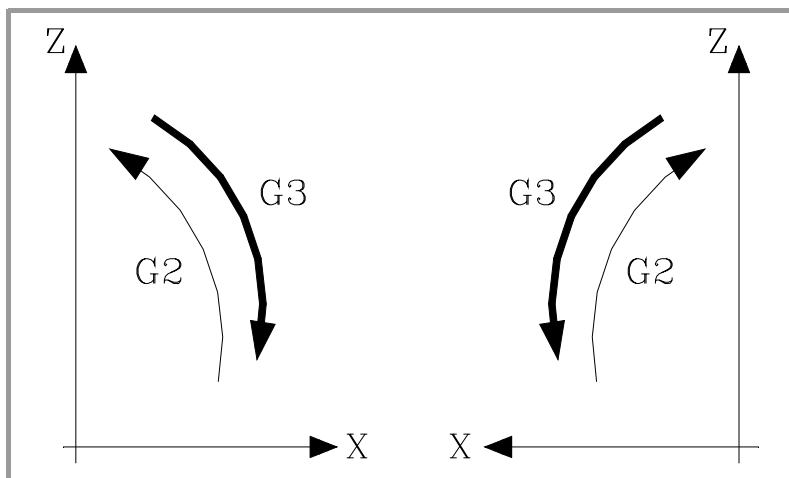

Circular interpolation can only be executed on a plane. The form of definition of circular interpolation is as follows :

6.

PATH CONTROL
Circular interpolation (G02, G03)



CNC 8055
CNC 8055i

·T· MODEL
(SOFT V16.1x)

Cartesian coordinates

The coordinates of the endpoint of the arc and the position of the center with respect to the starting point are defined according to the axes of the work plane.

The center coordinates are defined in radius by the letters I, J, or K, each one of these being associated to the axes as follows: When not defining the center coordinates, the CNC assumes that their value is zero.

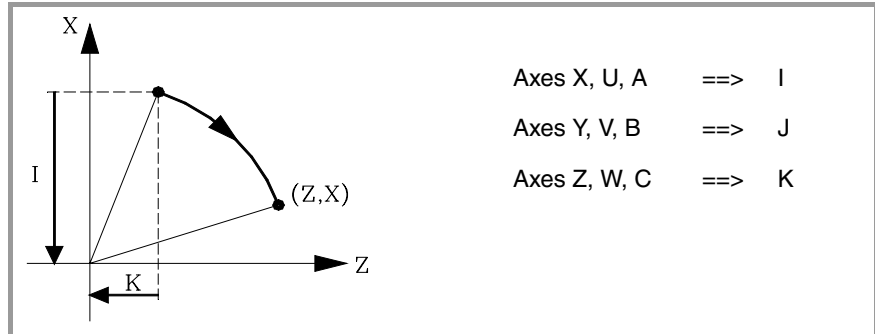

Programming format:

Plane XY:	G02(G03)	X±5.5	Y±5.5	I±6.5	J±6.5
Plane ZX:	G02(G03)	X±5.5	Z±5.5	I±6.5	K±6.5
Plane YZ:	G02(G03)	Y±5.5	Z±5.5	J±6.5	K±6.5

The programming order of the axes is always maintained regardless of the plane selected,, as are the respective center coordinates.

Plane AY:	G02(G03)	Y±5.5	A±5.5	J±6.5	I±6.5
Plane XU:	G02(G03)	X±5.5	U±5.5	I±6.5	I±6.5

Polar coordinates

It is necessary to define the angle to be traveled Q and the distance from the starting point to the center (optional), according to the axes of the work plane.

The center coordinates are defined in radius by the letters I, J, or K, each one of these being associated to the axes as follows:

Axes X, U, A	==>	I
Axes Y, V, B	==>	J
Axes Z, W, C	==>	K

If the center of the arc is not defined, the CNC will assume that it coincides with the current polar origin.

Programming format:

Plane XY:	G02(G03)	Q±5.5	I±6.5	J±6.5
Plane ZX:	G02(G03)	Q±5.5	I±6.5	K±6.5
Plane YZ:	G02(G03)	Q±5.5	J±6.5	K±6.5

6.

PATH CONTROL
Circular interpolation (G02, G03)



CNC 8055
CNC 8055i

.T- MODEL
(SOFT V16.1x)

Cartesian coordinates with radius programming

The coordinates of the endpoint of the arc and radius R are defined.

Programming format:

Plane XY: G02(G03) X±5.5 Y±5.5 R±6.5

Plane ZX: G02(G03) X±5.5 Z±5.5 R±6.5

Plane YZ: G02(G03) Y±5.5 Z±5.5 R±6.5

If a complete circle is programmed, with radius programming, the CNC will show the corresponding error, as infinite solutions exist.

If an arc is less than 180°, the radius is programmed with a plus sign, and a minus sign if it is more than 180°.

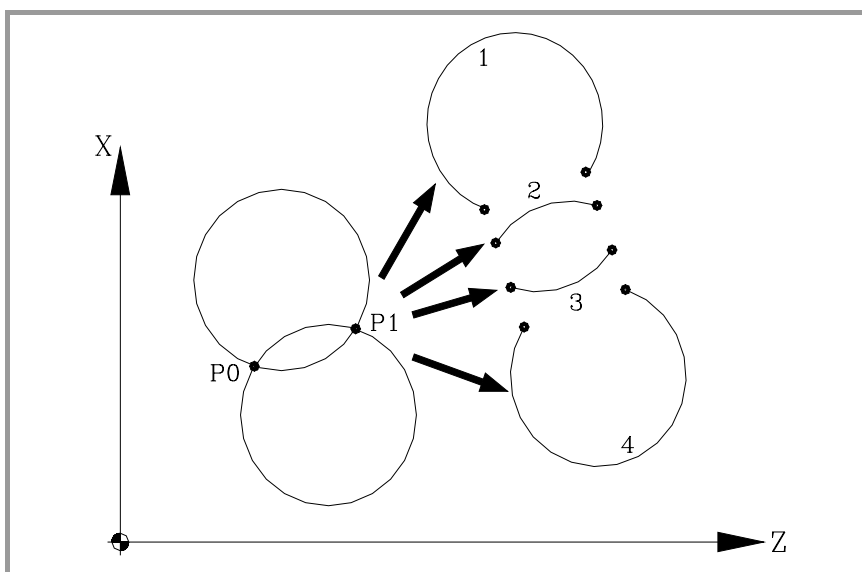

If P0 is the starting point and P1 the endpoint, there are 4 arcs which have the same value passing through both points.

Depending on the circular interpolation G02 or G03, and on the radius sign, the relevant arc is defined. Thus the programming format of the sample arcs is as follows:

Arc 1 G02 X.. Z.. R- ..

Arc 2 G02 X.. Z.. R+..

Arc 3 G03 X.. Z.. R+..

Arc 4 G03 X.. Z.. R- ..

Execution of the circular interpolation

From the programmed path, the CNC will calculate the radius for both the starting point and end point of the arc. Although both of them should be "exactly" the same, general parameter "CIRINERR" allows a certain calculation tolerance by establishing the maximum difference between these two radii. When exceeding this value, the CNC will issue the corresponding error message.

In all programming cases, the CNC checks that the coordinates of the center or radius do not exceed 214748.3647mm. Otherwise, the CNC will issue the corresponding error message.

The programmed feedrate "F" may vary between 0% and 120% via the switch located on the Control Panel of the CNC, or by selecting between 0% and 255% from the PLC, or via the DNC or the program.

6.

PATH CONTROL
Circular interpolation (G02, G03)

FAGOR 

CNC 8055
CNC 8055i

·T· MODEL
(SOFT V16.1X)

6.

PATH CONTROL
Circular interpolation (G02, G03)

The CNC, however, is equipped with the general machine parameter "MAXFOVR" to limit maximum feedrate variation.

If the general machine parameter "PORGMOVE" has been selected and a circular interpolation (G02 or G03) is programmed, the CNC assumes the center of the arc to be a new polar origin.

Functions G02 and G03 are modal and incompatible both among themselves and with G00, G01, G33 and G34. Functions G02 and G03 can be programmed as G2 and G3.

Also, function G74 (home search) and G75 (probing) cancel the G02 and G03 functions.

On power-up, after executing M02, M30 or after EMERGENCY or RESET, the CNC assumes code G00 or G01, depending on how general machine parameter "IMOVE" has been set.

Programming examples

Example programming the X axis in radius.

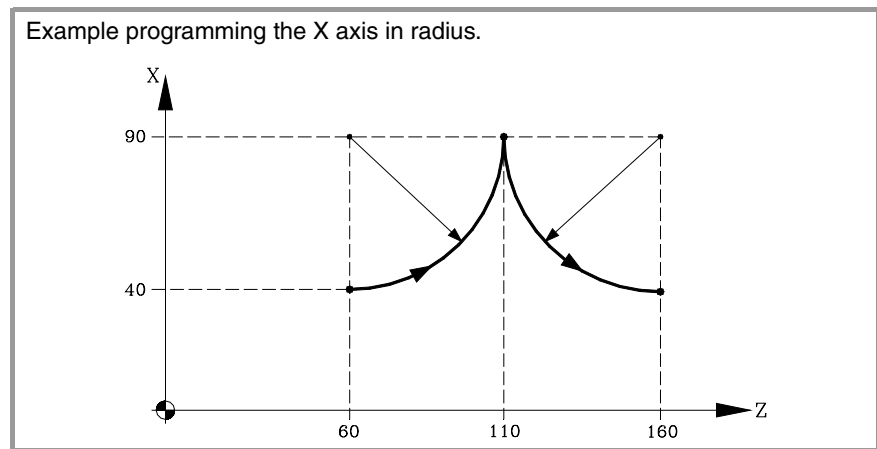

Various programming modes analyzed below, point X40 Z60 being the starting point.

Cartesian coordinates:

```
G90 G03 X90 Z110 I50 K0
X40 Z160 I10 K50
```

Polar coordinates:

```
G90 G03 Q0 I50 K0
Q-90 I0 K50
```

or:

```
G93 I90 J60 ; defines polar center
G03 Q0
G93 I90 J160 ; defines polar center
Q-90
```

Cartesian coordinates with radius programming:

```
G90 G03 X90 Z110 R50
X40 Z160 R50
```



CNC 8055
CNC 8055i

.T- MODEL
(SOFT V16.1x)

6.4 Circular interpolation with absolute arc center coordinates (G06)

By adding function G06 to a circular interpolation block you can program the coordinates of the center of the arc (I,J, or K) in absolute coordinates i.e. with respect to the zero origin and not to the beginning of the arc.

The center coordinates of each axis are programmed in either radius or diameter depending on the programming units set by axis machine parameter "DFORMAT".

Function G06 is not modal, so it should be programmed any time the coordinates of the center of the arc are required in absolute coordinates. G06 can be programmed as G6.

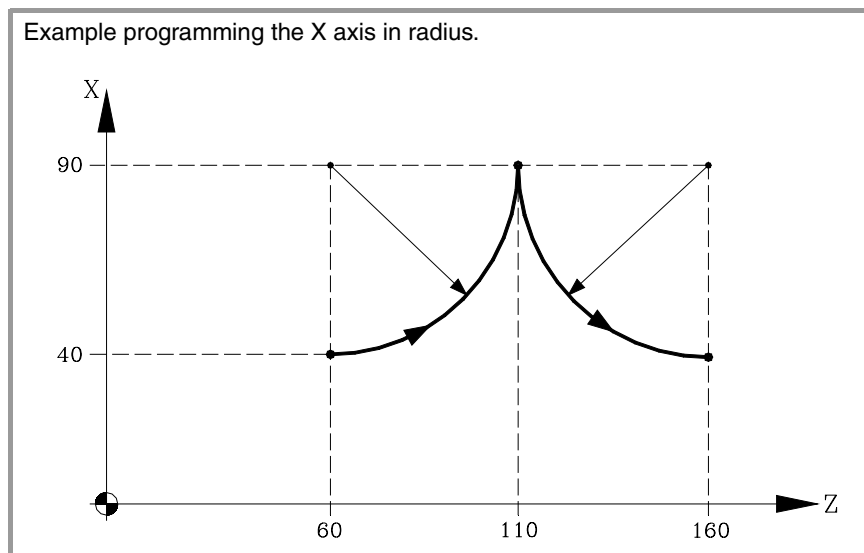

Various programming modes analyzed below, point X40 Z60 being the starting point.

Cartesian coordinates:

```
G90 G06 G03 X90 Z110 I90 K60
G06 X40 Z160 Y40 I90 K160
```

Polar coordinates:

```
G90 G06 G03 Q0 I90 K60
G06 Q-90 I90 K160
```

6.

PATH CONTROL

Circular interpolation with absolute arc center coordinates (G06)



CNC 8055
CNC 8055i

·T· MODEL
(SOFT V16.1X)

6.5 Arc tangent to previous path (G08)

Via function G08 you can program an arc tangential to the previous path without having to program the coordinates (I,J &K) of the center.

Only the coordinates of the endpoint of the arc are defined, either in polar coordinates or in Cartesian coordinates according to the axes of the work plane.

6.

PATH CONTROL
Arc tangent to previous path (G08)

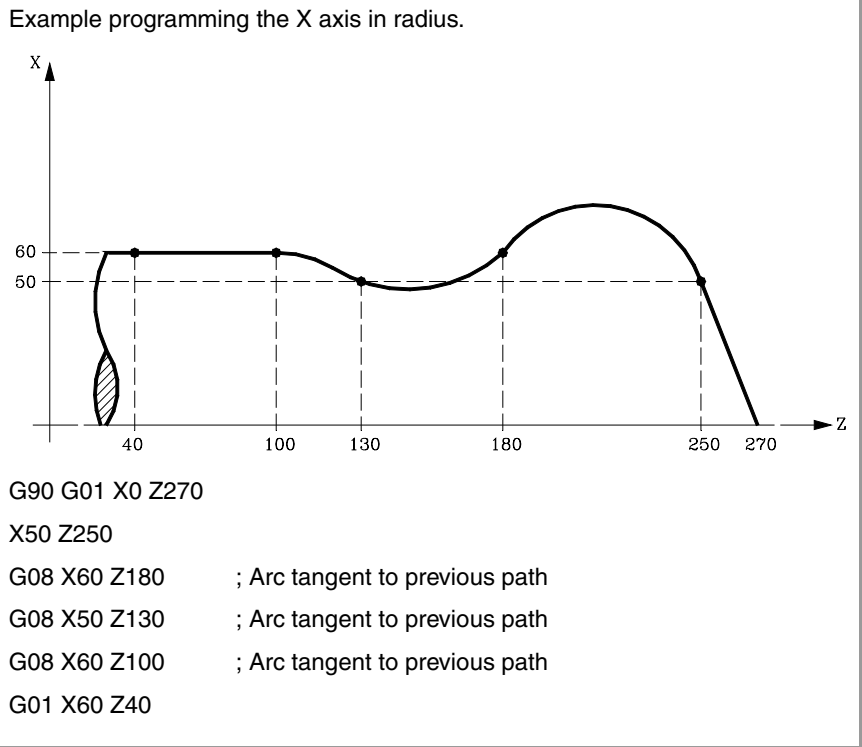

Function G08 is not modal, so it should always be programmed if you wish to execute an arc tangential to the previous path. Function G08 can be programmed as G8.

Function G08 enables the previous path to be a straight line or an arc and does not alter its history. The same function G01, G02 or G03 stays active after the block is finished.



When using function G08 it is not possible to execute a complete circle, as an infinite range of solutions exists. The CNC displays the corresponding error code.



CNC 8055
CNC 8055i

.T- MODEL
(SOFT V16.1x)

6.6 Arc defined by three points (G09)

Through function G09 you can define an arc by programming the endpoint and an intermediate point (the starting point of the arc is the starting point of the movement). In other words, instead of programming the coordinates of the center, you program any intermediate point.

The endpoint of the arc is defined in Cartesian or polar coordinates, and the intermediate point is always defined in Cartesian coordinates by the letters I,J, or K, each one being associated to the axes as follows:

Axes X, U, A ==> I

Axes Y, V, B ==> J

Axes Z, W, C ==> K

In Cartesian coordinates:

G18 G09 X±5.5 Z±5.5 I±5.5 K±5.5

Polar coordinates:

G18 G09 R±5.5 Q±5.5 I±5.5 K±5.5

Example:

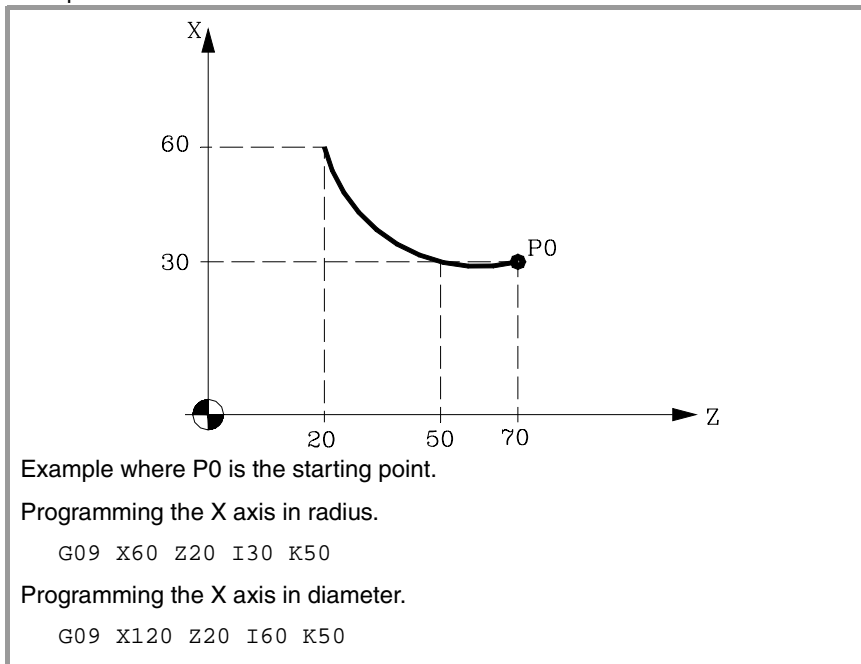

Function G09 is not modal, so it should always be programmed if you wish to execute an arc defined by three points. Function G09 can be programmed as G9.

When G09 is programmed it is not necessary to program the direction of movement (G02 or G03).

Function G09 does not alter the history of the program. The same G01, G02 or G03 function stays active after finishing the block.



When using function G09 it is not possible to execute a complete circle, as you have to program three different points. The CNC displays the corresponding error code.

6.

PATH CONTROL
Arc defined by three points (G09)

FAGOR

CNC 8055
CNC 8055i

·T· MODEL
(SOFT V16.1X)

6.7 Helical interpolation

A helical interpolation consists in a circular interpolation in the work plane while moving the rest of the programmed axes.

Normally used on special machines that have an auxiliary axis.

The helical interpolation is programmed in a block.

- The circular interpolation by means of functions: G02, G03, G08 or G09.
- Movement of the other axis or axes.

Example of a circular interpolation in the YZ plane and movement of the X axis:

```
G02 Y Z J K X
```

If the helical interpolation is supposed to make more than one turn, the linear movement of another axis must also be programmed (one axis only).

On the other hand, the pitch along the linear axis must also be set (format 5.5) by means of the I, J and K letters. Each one of these letters is associated with the axes as follows:

Axes X, U, A ==> I

Axes Y, V, B ==> J

Axes Z, W, C ==> K

Example:

Example of a circular interpolation in the YZ plane and movement of the X axis with a helical pitch of 5 mm:

```
G02 Y Z J K X I5
```

6.

PATH CONTROL
Helical interpolation



CNC 8055
CNC 8055i

.T- MODEL
(SOFT V16.1X)

6.8 Tangential entry at the beginning of a machining operation (G37)

Via function G37 you can tangentially link two paths without having to calculate the intersection points.

Function G37 is not modal, so it should always be programmed if you wish to start a machining operation with tangential entry:

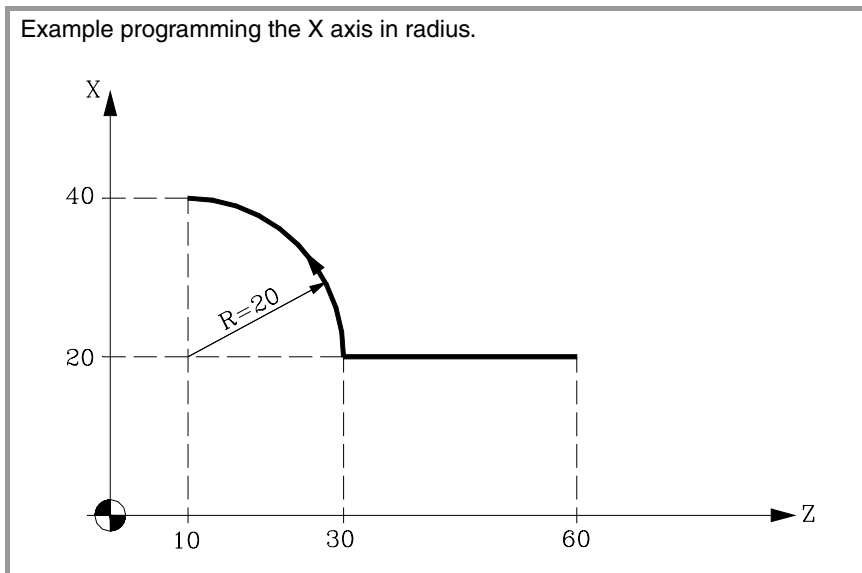

If the starting point is X20 Z60 and you wish to machine an arc (the path of approach being straight) you should program:

```
G90 G01 X20 Z30
G03 X40 Z10 R20
```

6.

PATH CONTROL
Tangential entry at the beginning of a machining operation (G37)

FAGOR 

CNC 8055
CNC 8055i

·T· MODEL
(SOFT V16.1X)

6.

PATH CONTROL

Tangential entry at the beginning of a machining operation (G37)

If, however, in the same example you require the entrance of the tool to the part to be machined tangential to the path and describing a radius of 5 mm, you should program:

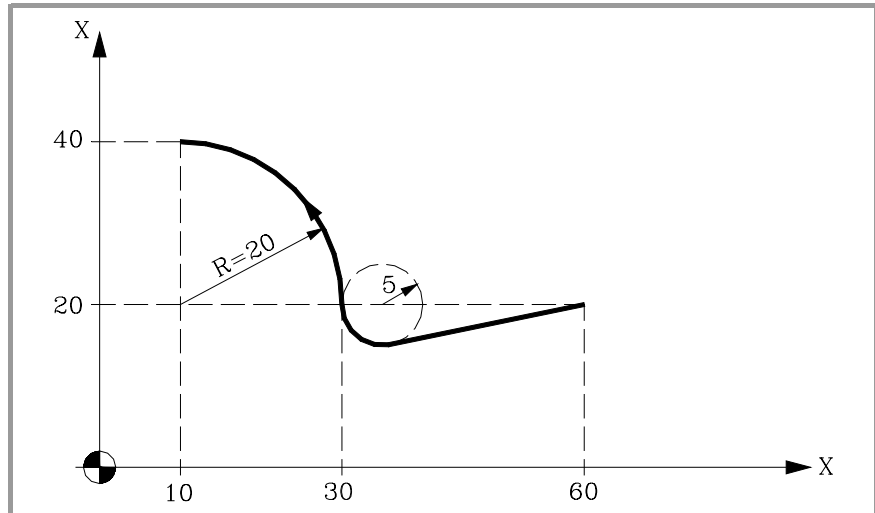

```
G90 G01 G37 R5 R5 X20 Z30
G03 X40 Z10 R20
```

As can be seen in the figure, the CNC modifies the path so that the tool starts to machine with a tangential entry to the part.

You have to program Function G37 plus value R in the block which includes the path you want to modify.

R5.5 should appear in all cases following G37, indicating the radius of the arc which the CNC enters to obtain tangential entry to the part. This R value must always be positive.

Function G37 should only be programmed in the block which includes a straight-line movement (G00 or G01). If you program in a block which includes circular movement (G02 or G03), the CNC displays the corresponding error.



CNC 8055
CNC 8055i

.T- MODEL
(SOFT V16.1x)

6.9 Tangential exit at the end of a machining operator (G38)

Function G38 enables the ending of a machining operation with a tangential exit of the tool. The path should be in a straight line (G00 or G01). Otherwise, the CNC will display the corresponding error.

Function G38 is not modal, so it should be programmed whenever a tangential exit of the tool is required.

Value R 5.5 should always appear after G38. It also indicates the radius of the arc which the CNC applies to get a tangential exit from the part. This R value must always be positive.

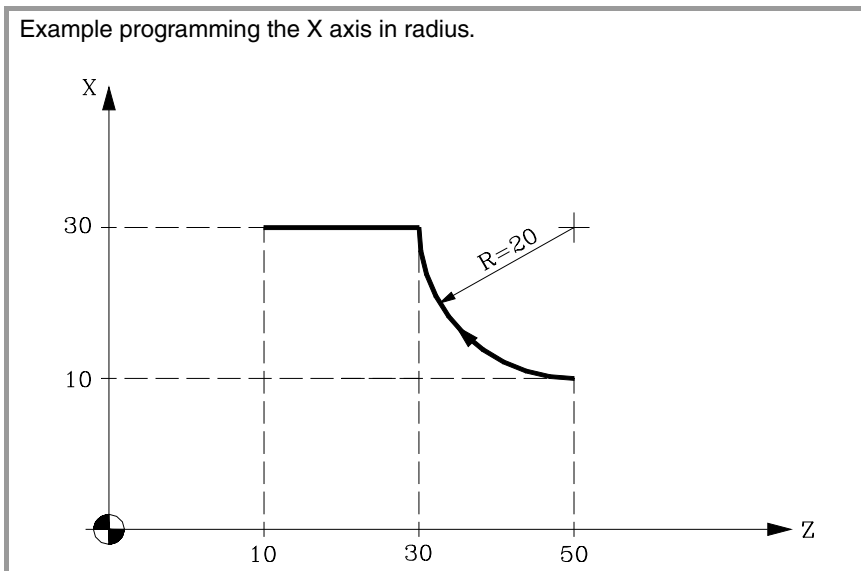

If the starting point is X0 Y30 and you wish to machine an arc (the exit paths being straight) you must program:

```
G90 G02 X30 Z30 R20
G01 X30 Z10
```

If, however, in the same example you wish the exit from machining to be done tangentially and describing a radius of 5 mm, you should program :

```
G90 G02 G38 R5 X30 Z30 R20
G00 X30 Z10
```

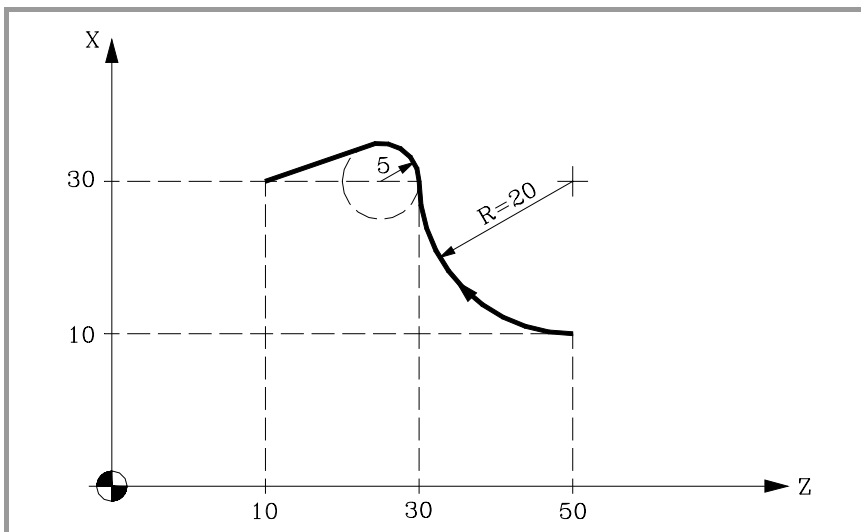

6.

PATH CONTROL
Tangential exit at the end of a machining operator (G38)



CNC 8055
CNC 8055i

·T· MODEL
(SOFT V16.1x)

6.10 Automatic radius blend (G36)

It is possible to round a corner via function G36 with a particular radius, without having to calculate the center nor the start and end points of the arc.

Function G36 is not modal, so it should be programmed whenever controlled corner rounding is required.

This function should be programmed in the block in which the movement the end you want to round is defined.

The R5.5 value should always follow G36. It also indicates the rounding radius which the CNC applies to get the required corner rounding. This R value must always be positive.

6.

PATH CONTROL
Automatic radius blend (G36)

Example programming the X axis in diameter.

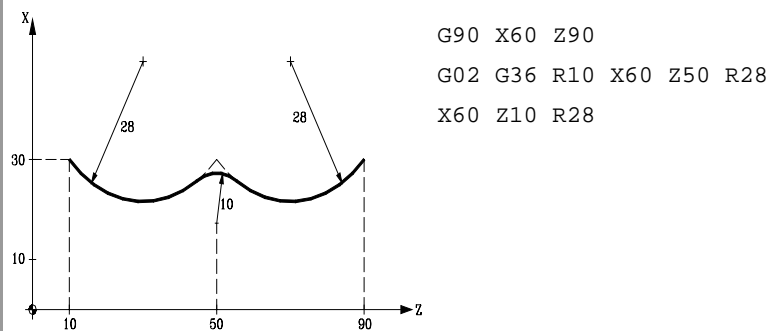
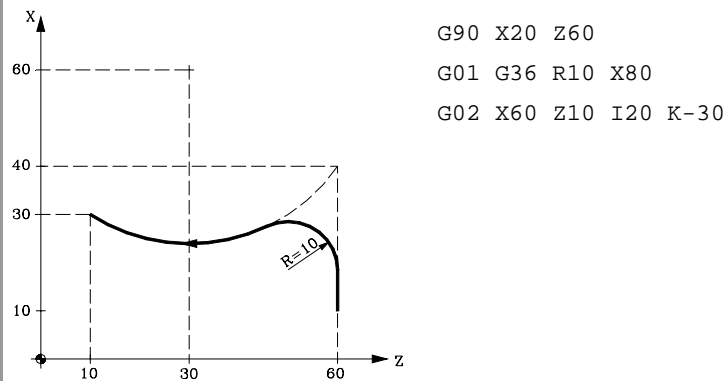
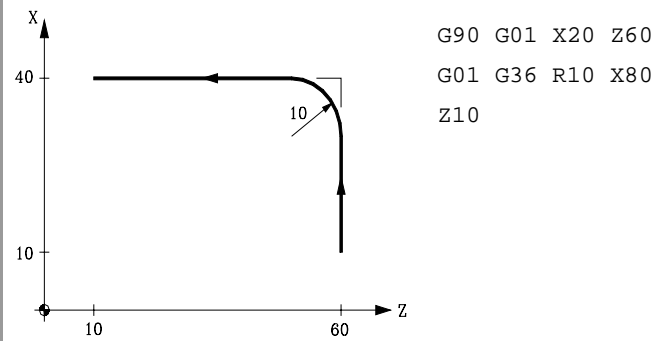

CNC 8055
CNC 8055i

.T- MODEL
(SOFT V16.1x)

6.11 Chamfer (G39)

In machining operations it is possible (using G39) to chamfer corners between two straight lines, without having to calculate intersection points.

Function G39 is not modal, so it should be programmed whenever the chamfering of a corner is required.

This function should be programmed in the block in which the movement whose end you want to chamfer is defined.

The R5.5 value should always follow G39. It also indicates the distance from the end of the programmed movement as far as the point where you wish to carry out the chamfering. This R value must always be positive.

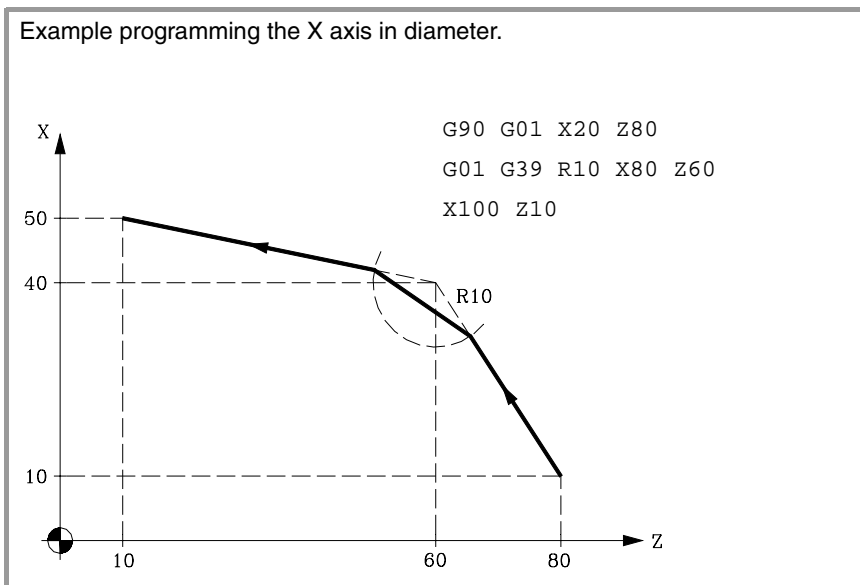

6.

PATH CONTROL
Chamfer (G39)

FAGOR 

CNC 8055
CNC 8055i

·T· MODEL
(SOFT V16.1X)

6.12 Threading (G33)

If the machine spindle is equipped with a rotary encoder, you can thread with a tool tip via function G33.

Although this threading is often done along the entire length of an axis, the CNC enables threading to be done interpolating more than one axis at a time.

Programming format:

```
G33 X.....C L Q
```

X...C ±5.5 End point of the thread

L 5.5 Thread pitch

Q ±3.5 Optional. It indicates the spindle angular position (±359.9999) of the thread's starting point. This makes it possible to make threads with multiple entries. If not programmed, a value of 0 is assumed.

Considerations

Whenever G33 is executed, if s.m.p. M19TYPE (P43) =0, and before making the thread, the CNC references the spindle (home search).

Spindle machine parameter M19TYPE (P43) must be set to "1" in order to be able to program parameter Q (angular spindle position).

When executing function G33 Q (s.m.p. M19TYPE (P43) =1), spindle had to be homed after the last power-up and before executing the thread.

When executing function G33 Q (s.m.p. M19TYPE (P43) =1) and s.m.p. DECINPUT (P31) =NO, no home search is needed because the spindle will be homed automatically after power-up when turning the spindle in M3 or in M4 for the first time.

This search will be carried out at the feedrate set by s.m.p. REFEED2 (P35). After finding home, the spindle will speed up or slow down to the programmed speed without stopping.

If the spindle has motor feedback with a SINCOS encoder (without reference mark), the home search will be done directly at the programmed S speed without going through the speed set by s.m.p. REFEED2.

If after power-up, an M19 is executed before an M3 or M4, that M19 will be executed without homing the spindle when executing the first M3 or M4.

If the feedback device does not have the reference mark synchronized, the home search in M3 might not coincide with the home search in M4. This does not happen with FAGOR feedback.

When working in round corner mode (G05), it is possible to blend different threads in the same part. When joining threads, only the first one may have an entry angle (Q).

While function G33 is active, neither the programmed feedrate "F" nor the programmed Spindle speed "S" can be varied. They will both be set to 100%. The spindle override is ignored both during machining and when moving back.

Function G33 is modal and incompatible with G00, G01, G02, G03, G34 and G75.

On power-up, after executing M02, M30 or after EMERGENCY or RESET, the CNC assumes code G00 or G01, depending on how general machine parameter "IMOVE" has been set.

6.

PATH CONTROL
Threading (G33)



CNC 8055
CNC 8055i

-T- MODEL
(SOFT V16.1x)

Programming examples

In the following examples, the X axis is programmed in diameter.

Longitudinal threadcutting

We would like to make a thread in a single pass with a depth of 2mm and a pitch of 5 mm.

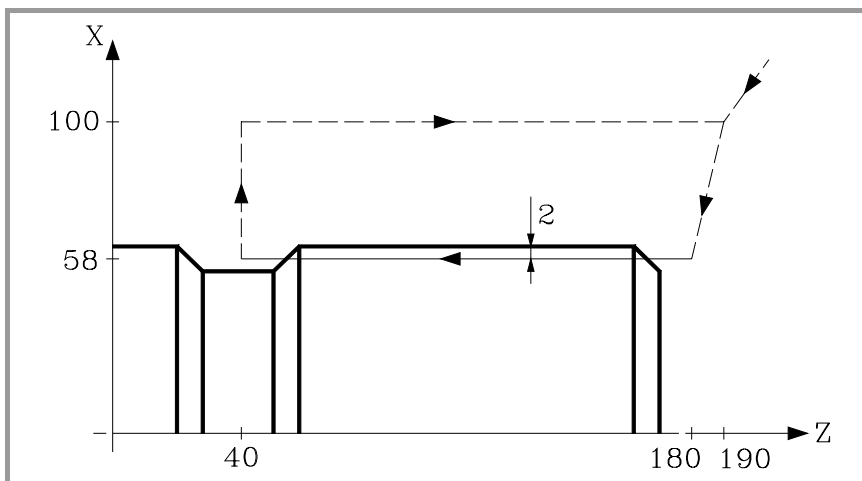

```
G90 G00 X200 Z190
X116 Z180
G33 Z40 L5 ; Threadcutting.
G00 X200
Z190
```

Longitudinal multiple threadcutting

To make a longitudinal thread with two entries. The threads are shifted 180° and each one has a depth of 2mm and a pitch of 5 mm.

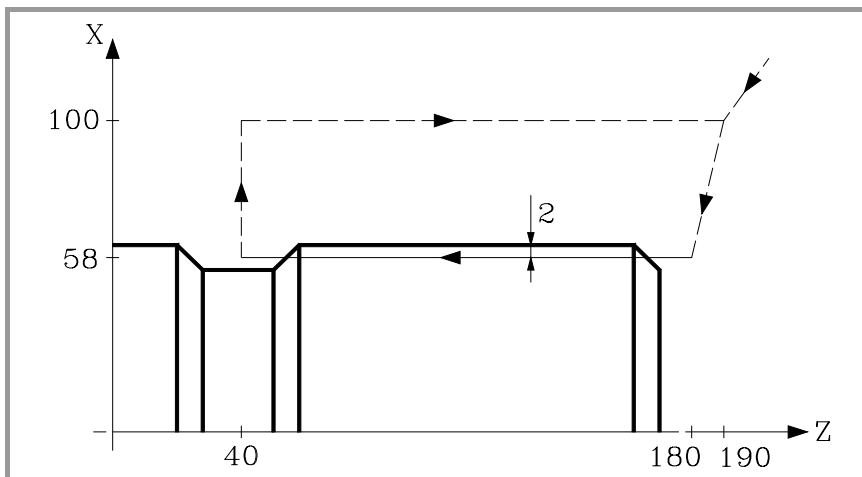

```
G90 G00 X200 Z190
X116 Z180
G33 Z40 L5 Q0 ; First threadcutting.
G00 X200
Z190
X116 Z180
G33 Z40 L5 Q180 ; Second threadcutting.
G00 X200
Z190
```

6.

PATH CONTROL
Threading (G33)



CNC 8055
CNC 8055i

·T· MODEL
(SOFT V16.1x)

6.

PATH CONTROL
Threading (G33)

Taper thread

We would like to make a taper thread in a single pass with a depth of 2mm and a pitch of 5 mm.

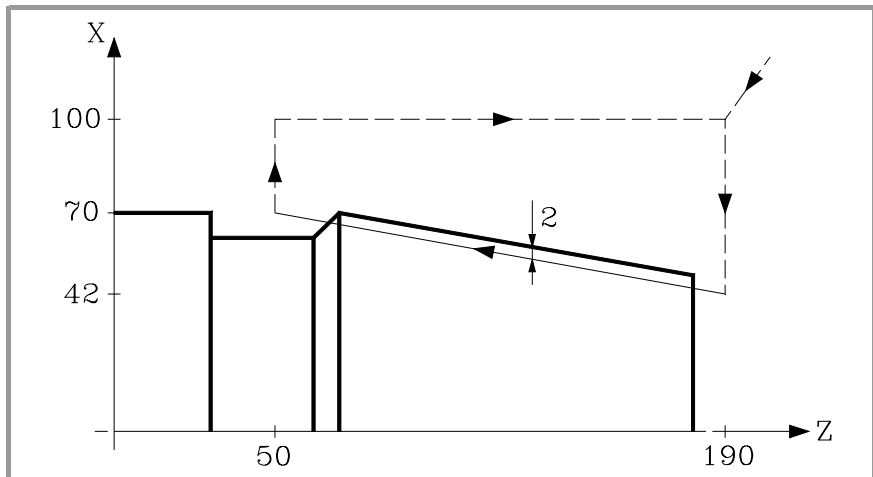

```
G90 G00 X200 Z190
X84
G33 X140 Z50 L5 ; First threadcutting.
G00 X200
Z190
```

Thread blending (joining)

We would like to blend a longitudinal thread with a taper thread with a depth of 2mm and a pitch of 5 mm.

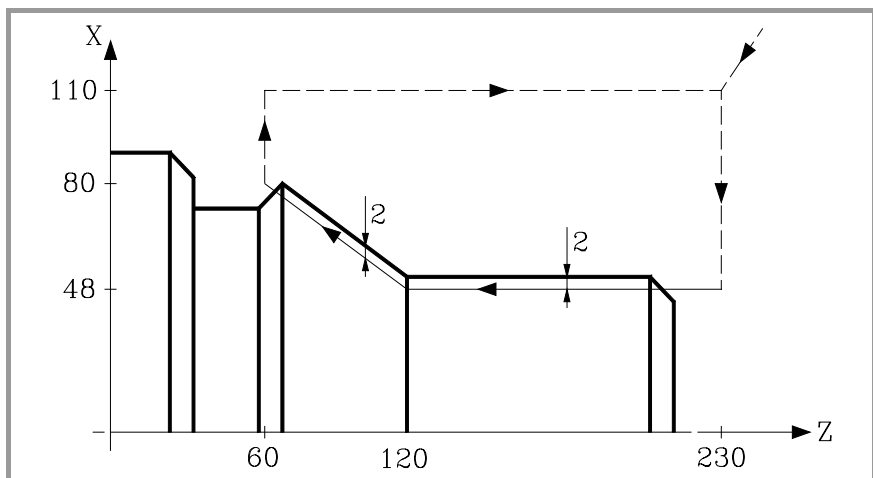

```
G90 G00 G05 X220 Z230
X96
G33 Z120 L5 ; Longitudinal threadcutting.
Z160 Z60 L5 ; Taper threadcutting.
G00 X200
Z230
```



CNC 8055
CNC 8055i

.T- MODEL
(SOFT V16.1x)

6.13 Withdrawal of axes when interrupting a threading operation (G233)

With function G233 it is possible to program the safety distance the axes withdraw to when interrupting a thread (G33) either using the [STOP] key or feedhold.

This function is modal, it must be programmed alone in the block and it is displayed in the history. This function determines the thread exit for all the threads programmed after it. If there are several G33 functions in a row and you would like to do a different withdrawal on each one of them, program the corresponding function G233 before each G33 function.

Function G233 may be canceled by programming it alone in a block or by programming all the coordinates as zero. In either case, G233 disappears from history.

If the [STOP] key is pressed while executing a thread and function G233 is active, the axes withdraw according to the distances programmed in that function. If after the withdrawal, there is an active DSTOP, it will keep executing the blocks until an ESTOP is found.

Programming format

G233 X...C

X...C +/-5.5 Thread exit distances.

Example:

- X: Incremental distance (positive or negative) to move along the thread exit axis (X axis).
- Z: Incremental distance to move along the thread axis (Z axis).

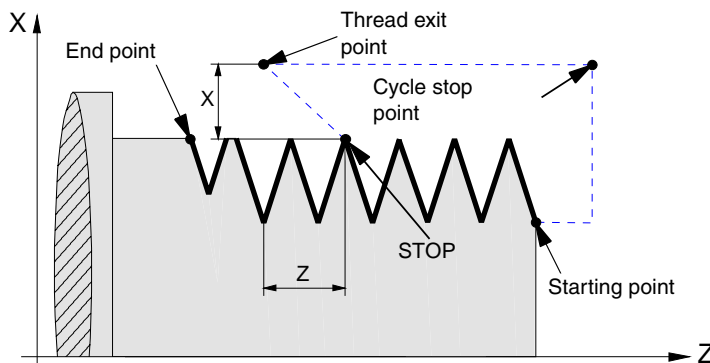

6.

PATH CONTROL

Withdrawal of axes when interrupting a threading operation (G233)

Programming example

Programming a thread with G33 and G233.

N10 G90 G18 S500 M3

N20 G0 X20

N30 Z0

N40 X10

N50 G233 X5 Z-20 ; Block activating the thread withdrawal (5mm in X and
-20mm in Z).

N60 G33 Z-30 L5 ;Threading block that may be interrupted with STOP.

N70 G33 X15 Z-50 L5 ;Block to exit previous thread.

Withdrawal of axes when interrupting a threading canned cycle (G86, G87)

In the threading cycles (G86, G87) where a thread exit has been programmed, there is no need to program a G233. The withdrawal distances will be indicated in parameters D and J of that cycle.

While executing those cycles, when pressing the [STOP] key or feedhold, once the tool has been withdrawn, it returns to the starting point of the cycle. Then, the machine remains stopped waiting for the [START] command to repeat the interrupted pass.



CNC 8055
CNC 8055i

.T- MODEL
(SOFT V16.1x)

6.14 Variable pitch threads (G34)

To make variable-pitch threads, the spindle of the machine must have a rotary encoder.

Although this threading is often done along the entire length of an axis, the CNC enables threading to be done interpolating more than one axis at a time.

Programming format:

```
G34 X...C L Q K
```

X...C ±5.5 End point of the thread

L 5.5 Thread pitch

Q ±3.5 Optional. It indicates the spindle angular position (±359.9999) of the thread's starting point. If not programmed, a value of "0" is assumed.

K ±5.5 Thread pitch increase or decrease per spindle turn.

Considerations

Whenever G34 is executed and before making the thread, the CNC references the spindle (home search) and positions the spindle at the angular position indicated by parameter Q.

Parameter "Q" is available when spindle machine parameter "M19TYPE" has been set to "1".

When working in round corner mode (G05), it is possible to blend different threads in the same part.

While function G34 is active, neither the programmed feedrate "F" nor the programmed Spindle speed "S" can be varied. They will both be set to 100%.

Function G34 is modal and incompatible with G00, G01, G02, G03, G33 and G75.

On power-up, after executing M02, M30 or after EMERGENCY or RESET, the CNC assumes code G00 or G01, depending on how general machine parameter "IMOVE" has been set.

Blending a fixed-pitch thread (G33) with a variable-pitch thread (G34).

The starting thread pitch (L) of the G34 must coincide with the thread pitch of the G33.

The pitch increase in the first turn of the spindle in variable pitch will be half and increment (K/2) and in the rest of the turns it will be the full increment K.

Blending a variable-pitch thread (G34) with a fixed-pitch thread.

It is used to finish a variable-pitch thread (G34) with a portion of the thread keeping the final pitch of the previous thread. The fixed-pitch thread is not programmed with G33 but with G34 ... L0 K0.

Blending two variable-pitch threads (G34).

Two variable-pitch threads (G34) cannot be blended together.

6.

PATH CONTROL
Variable pitch threads (G34)

FAGOR 

CNC 8055
CNC 8055i

·T· MODEL
(SOFT V16.1X)

6.15 Activates the C axis (G15)

6.

PATH CONTROL

Activates the C axis (G15)

The preparatory function G15 activates the C axis so it can machine on the side of the part or on its face.

This feature is optional and requires a software that can control 4 or more axes.

In order to use this preparatory function, it is necessary to set one of the axes of the machine as C axis (general machine parameter P0 through P7) and define that axis as a regular rotary axis (C axis machine parameter "AXISTYPE").

When activating the C axis with preparatory function G15, the CNC executes a home search on the C axis if it was working as a spindle before. If it was already in C axis mode, the home search will not be carried out.

The G15 function is modal and it will keep active the spindle logic output "CAXIS (M5955) all the time while the C axis is active.

No more auxiliary functions may be programmed in the same block that defined function G15.

The CNC cancels the C axis and it returns it to spindle mode after executing one of these spindle functions (M03, M04, M05, etc.).

Also, if general machine parameter "PERCAX=NO", the CNC will also cancel the C function after turning the CNC off and back on, after an emergency or reset or after executing functions M02 and M30.

6.15.1 Machining on the side of the part

To machine on the cylindrical side of the part, first define the radius of the cylinder with the function G15 R and then select the main plane using the function G16 ZC.

Then program the profile to be machined; linear and circular interpolations may be programmed as well as tool radius compensation.

The C axis is programmed as if it were a linear axis, the CNC will calculate the corresponding angular movement according to the radius selected with G15 R.

To change the radius while programming the profile, program G15 R again.

Example programming the X axis in diameters, assuming that the radius used to make the groove on the cylinder is R20:



CNC 8055
CNC 8055i

.T- MODEL
(SOFT V16.1X)

```

G15 R20
G16 ZC
G90 G42 G01 Z70 C0 ; Positioning at starting point
G91 X-4 ; Penetration
G90 G36 R5 C15,708
G36 R3 Z130 C31.416
G36 R3 C39,270
G36 R3 Z190 C54.978
G36 R3 C70.686
G36 R3 Z130 C86.394
G36 R3 C94.248
G36 R3 Z70 C109.956
G36 R3 C125.664
G91 X4 ; Withdrawal
M30
    
```

6.

PATH CONTROL
Activates the C axis (G15)



CNC 8055
CNC 8055i

·T· MODEL
(SOFT V16.1X)

6.15.2 Machining on the face of the part

To machine on the face of the part, first define the function G15 and then select the main plane using the function G16 XC.

Then program the profile to be machined; linear and circular interpolations may be programmed as well as tool radius compensation.

The C axis is programmed as if it were a linear axis and the values assigned to the X axis are assumed to be in radius regardless of the value assigned to X axis machine parameter "DFORMAT".

6.

PATH CONTROL
Activates the C axis (G15)

```

G15
G16 XC
G0 X30 ; Positioning at starting point
G0 X-2 ; Penetration
G01 G90 X15 F1000
X0 C-10
X -12
C10
X0
X15 C0
X30
G0 Z20 ; Withdrawal
M30
    
```



CNC 8055
CNC 8055i

.T- MODEL
(SOFT V16.1x)

6.16 Move to hardstop (G52)

By means of function G52 it is possible to program the movement of an axis until running into an object. This feature may be interesting for forming machines, live tailstocks, bar feeders, etc.

The programming format is:

```
G52 X..C ±5.5
```

After G52, program the desired axis as well as the target coordinate of the move.

The axis will move towards the programmed target coordinate until running into something. If the axis reaches the programmed target coordinate without running into the hardstop it will stop.

Function G52 is not modal; therefore, it must be programmed every time this operation is to be carried out.

Also, it assumes functions G01 and G40 modifying the program history. It is incompatible with functions G00, G02, G03, G33, G34, G41, G42, G75 and G76.

6.**PATH CONTROL**
Move to hardstop (G52)**FAGOR** **CNC 8055
CNC 8055i**·T· MODEL
(SOFT V16.1X)

6.17 Feedrate "F" as an inverted function of time (G32)

6.

PATH CONTROL

Feedrate "F" as an inverted function of time (G32)

There are instances when it is easier to define the time required by the various axes of the machine to reach the target point instead of defining a common feedrate for all of them.

A typical case may be when a linear axis (X, Z) has to move together (interpolated) with a rotary axis programmed in degrees.

Function G32 indicates that the "F" functions programmed next set the time it takes to reach the target point.

In order for a greater value of "F" to indicate a greater feedrate, the value assigned to "F" is defined as "Inverted function of time" and it is assumed as the activation of this feature.

"F" units: 1/min

Example: G32 X22 F4

indicates that the movement must be executed in 1/4 minute; i.e. in 0.25 minutes.

Function G32 is modal and incompatible with G94 and G95.

On power-up, after executing M02, M30 or after an Emergency or Reset, the CNC assumes G94 or G95 depending on the setting of general machine parameter "IFFED".

Considerations

The CNC variable PROGFIN will show the feedrate programmed as an inverted function of time and variable FEED will show the resulting feedrate in mm/min or inches/min.

If the resulting feedrate of any axis exceeds the maximum value set by machine parameter "MAXFEED", the CNC will apply this maximum value.

The programmed "F" is ignored on G00 movements. All the movements will be carried out at the feedrate set by axis machine parameter "G00FEED".

When programming "F0" the movement will be carried out at the feedrate set by axis machine parameter "MAXFEED".

Function G32 may be programmed and executed in the PLC channel.

Function G32 is canceled in JOG mode.



CNC 8055
CNC 8055i

.T- MODEL
(SOFT V16.1x)

6.18 Tangential control (G45)

With the "Tangential control" feature, the axis may maintain the same orientation with respect to the programmed path.

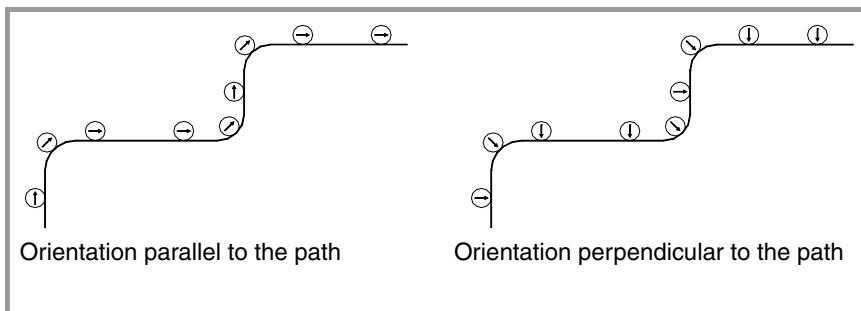

The path is defined by the axes of the active plane. The axis maintaining the orientation must be a rotary rollover axis (A, B or C).

Programming format:

G45 Axis Angle

Axis Axis maintaining the orientation (A, B or C).

Angle Indicates the angular position in degrees with respect to the path (± 359.9999). If not programmed, "0" will be assumed.

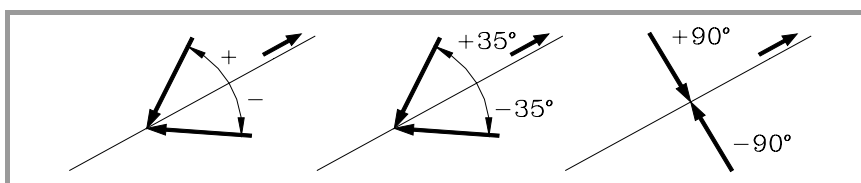

To cancel this function, program G45 alone (without defining the axis).

Every time G45 (tangential control) is activated, the CNC acts as follows:

1. Positions the tangential axis, with respect to the first section in the programmed position.

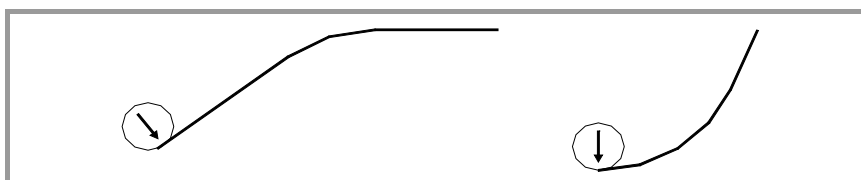

2. The interpolation of the plane axes starts once the tangential axis has been positioned.
3. The orientation of the tangential axis is maintained in linear sections whereas in circular interpolations the programmed orientation is maintained throughout the whole travel.

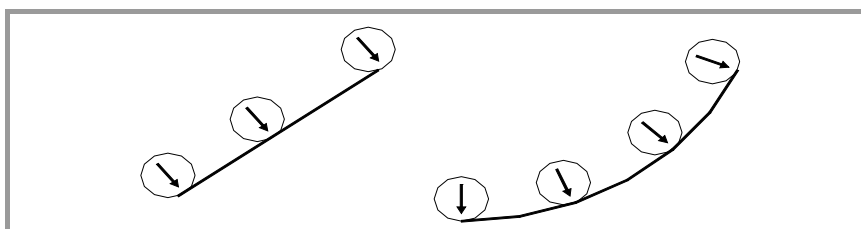

6.

PATH CONTROL
Tangential control (G45)

FAGOR 

CNC 8055
CNC 8055i

·T· MODEL
(SOFT V16.1X)

6.

PATH CONTROL
Tangential control (G45)

4. If the joint of sections requires a new orientation of the tangential axis, the following takes place:
 1. Ends the current section.
 2. Orients the tangential axis with respect to the next section.
 3. Resumes the execution.

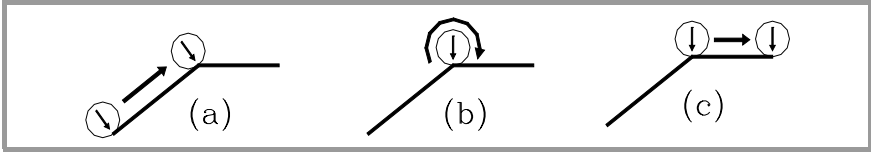

When working in round corner (G05), the tool orientation is not maintained at the corners since it begins before ending the current section.

It is recommended to work in square corner (G07). However, to work in round corner (G05), function G36 (automatic radius blend) should be used in order to also maintain tool orientation at the corners.

5. To cancel this function, program G45 alone (without defining the axis).

Even when the tangential axis takes the same orientation by programming 90° or -270° , the turning direction in a direction change depends on the programmed value.

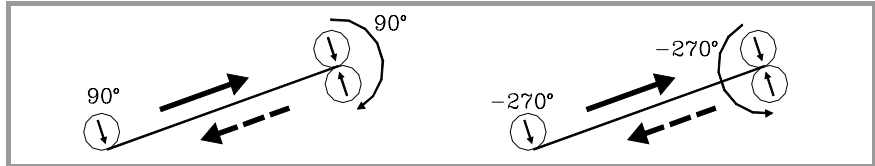

CNC 8055
CNC 8055i

.T- MODEL
(SOFT V16.1X)

6.18.1 Considerations about the G45 function

Tangential control, G45, is optional. It can only be executed in the main channel and is compatible with:

- Tool radius and length compensation (G40, 41, 42, 43, 44).
- Mirror image (G10, 11, 12, 13 14).
- Gantry axes , including the gantry axis associated with the tangential rotary axis.

The maximum feedrate while orienting the tangential axis is defined by machine parameter MAXFEED for that axis.

While tangential control is active, tool inspection is also possible. When accessing tool inspection, the tangential control is deactivated, the axes are free and when quitting tool inspection, tangential control may be activated again.

While in JOG mode, tangential control may be activated in MDI mode and the axes may be moved by programming blocks in MDI.

Tangential control is canceled when jogging the axes with the jog keys (not in MDI). Once the movement is over, tangential control is recovered.

Likewise, the following is NOT possible:

- To define as tangential axis, one of the plane axes, the longitudinal axis or any other axis which is not rotary.
- To jog the tangential axis in JOG mode or by program using another G code while tangential control is active.
- Incline planes.

The TANGAN variable is read-only, from the CNC, PLC and DNC, associated with function G45. It indicates the angular position, in degrees, referred to the programmed path.

Also, general logic output TANGACT (M5558) indicates to the PLC that function G45 is active.

Function G45 is modal and is canceled when executing G45 alone (without defining the axis), on power-up, after executing an M02 or M30 or after an EMERGENCY or RESET.

6.

PATH CONTROL
Tangential control (G45)

FAGOR 

CNC 8055
CNC 8055i

·T· MODEL
(SOFT V16.1x)

6.19 G145. Temporary cancellation of tangential control

Function G145 may be used to cancel the tangential control (G145) temporarily:

- G145 K0** It cancels the tangential control temporarily. Function G45 stays in the history and the new function G145 comes up in it.
- If no G45 has been programmed, G145 is ignored. If K is not programmed, K0 will be assumed.
- G145 K1** It resumes the tangential control of the axis with the angle it had before it was canceled. Then, G145 disappears from history.

6.

PATH CONTROL

G145. Temporary cancellation of tangential control



CNC 8055
CNC 8055i

.T- MODEL
(SOFT V16.1X)

ADDITIONAL PREPARATORY FUNCTIONS

7

7.1 Interruption of block preparation (G04)

The CNC reads up to 20 blocks ahead of the one it is executing, with the aim of calculating beforehand the path to be followed.

Each block is evaluated (in its absence) at the time it is read, but if you wish to evaluate it at the time of execution of the block you use function G04.

This function holds up the preparation of blocks and waits for the block in question to be executed in order to start the preparation of blocks once more.

A case in point is the evaluation of the "status of block-skip inputs" which is defined in the block header.

Example:

```
.  
. G04 ; Interrupts block preparation  
/1 G01 X10 Z20 ; block-skip condition "/1"  
. .
```

Function G04 is not modal, so it should be programmed whenever you wish to interrupt block preparation.

It should be programmed on its own and in the block previous to the one in which the evaluation in execution is required. Function G04 can be programmed as G4.

Every time G04 is programmed, active radius and length compensation are cancelled.

For this reason, care needs to be taken when using this function, because if it is introduced between machining blocks which work with compensation, unwanted profiles may be produced.



CNC 8055
CNC 8055i

·T· MODEL
(SOFT V16.1x)

7.

ADDITIONAL PREPARATORY FUNCTIONS
Interruption of block preparation (G04)

Example: The following program blocks are performed in a section with G41 compensation.

```

...
N10 X80 Z50
N15 G04
/1 N17 M10
N20 X50 Z50
N30 X50 Z80
...

```

Block N15 interrupts block preparation and the execution of block N10 will finish at point A.

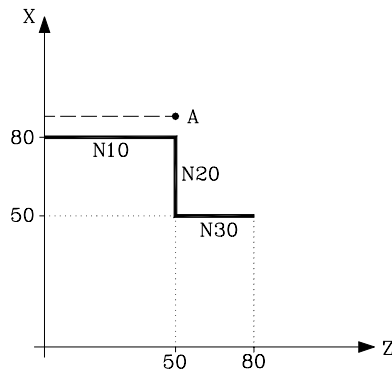

Once the execution of block N15 has been carried out, the CNC continues preparing blocks starting from block N17.

As the next point corresponding to the compensated path is point "B", the CNC will move the tool to this point, executing path "A-B".

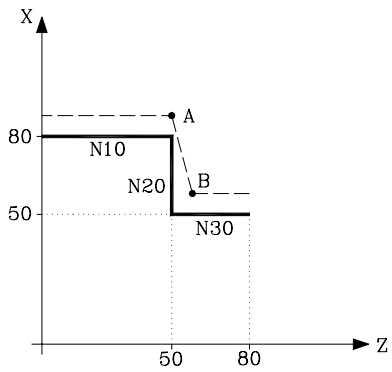

As you can see, the resulting path is not the required one, so we recommend avoiding the use of function G04 in sections which work with compensation.



CNC 8055
CNC 8055i

.T- MODEL
(SOFT V16.1x)

7.1.1 G04 K0: Block preparation interruption and coordinate update

The function associated with G04 K0 may be used to update the coordinates of the axes of the channel after finishing particular PLC maneuvers.

The PLC maneuvers that require updating the coordinates of the axes of the channel are the following:

- PLC maneuver using the SWITCH* marks.
- PLC maneuvers where an axis goes into DRO mode and then back into normal axis mode during the execution of part programs.

G04 operation:

Function	Description
G04	Interrupts block preparation.
G04 K50	It executes a dwell 50 hundredths of a second.
G04 K0 or G04 K	It interrupts block preparation and updates the CNC coordinates to the current position. (G4 K0 works in the CNC and PLC channel).



ADDITIONAL PREPARATORY FUNCTIONS
Interruption of block preparation (G04)



CNC 8055
CNC 8055i

·T· MODEL
(SOFT V16.1X)

7.2 Dwell (G04 K)

A dwell can be programmed via function G04 K.

The dwell value is programmed in hundredths of a second via format K5 (1..99999).

Example:

G04 K50 ; Dwell of 50 hundredths of a second (0.5 seconds)

G04 K200 ; Dwell of 200 hundredths of a second (2 seconds)

Function G04 K is not modal, so it should be programmed whenever a dwell is required. Function G04 K can be programmed as G4 K.

The dwell is executed at the beginning of the block in which it is programmed.

Note: When programming G04 K0 or G04 K, instead of applying a delay, it only interrupts block preparation and it will refresh the coordinates. See ["7.1.1 G04 K0: Block preparation interruption and coordinate update"](#) on page 81.

7.

ADDITIONAL PREPARATORY FUNCTIONS
Dwell (G04 K)



CNC 8055
CNC 8055i

.T- MODEL
(SOFT V16.1X)

7.3 Working with square (G07) and round (G05,G50) corners

7.3.1 G07 (square corner)

When working in G07 (square corner) the CNC does not start executing the following program block until the position programmed in the current block has been reached.

The CNC considers that the programmed position has been reached when the axis is within the "INPOSW" (in-position zone or dead band) from the programmed position.

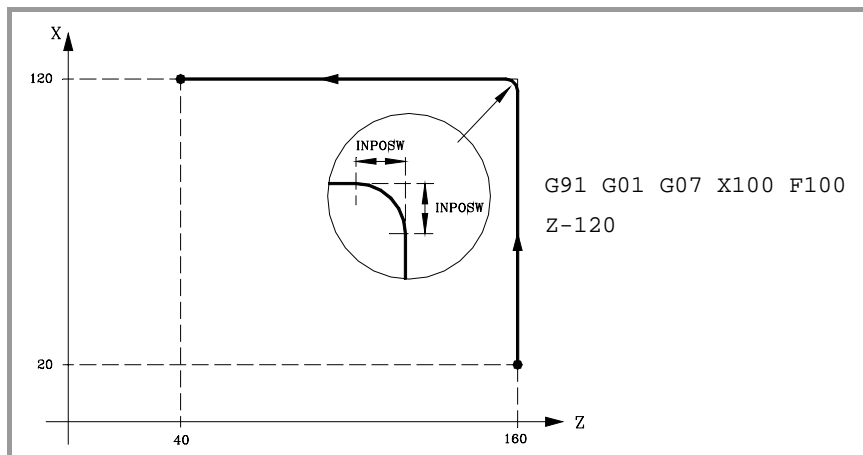

The theoretical and real profile coincide, obtaining square corners, as seen in the figure.

Function G07 is modal and incompatible with G05, G50 and G51. Function G07 can be programmed as G7.

On power-up, after executing M02, M30 or after EMERGENCY or RESET, the CNC assumes code G05 or G07 depending on how the general machine parameter "ICORNER" is set.

7.

ADDITIONAL PREPARATORY FUNCTIONS
Working with square (G07) and round (G05,G50) corners

FAGOR 

**CNC 8055
CNC 8055i**

·T· MODEL
(SOFT V16.1X)

7.3.2 G05 (round corner)

When working in G05 (round corner), the CNC starts executing the following block of the program as soon as the theoretical interpolation of the current block has concluded. It does not wait for the axes to physically reach the programmed position.

The distance prior to the programmed position where the CNC starts executing the next block depends on the actual axis feedrate.

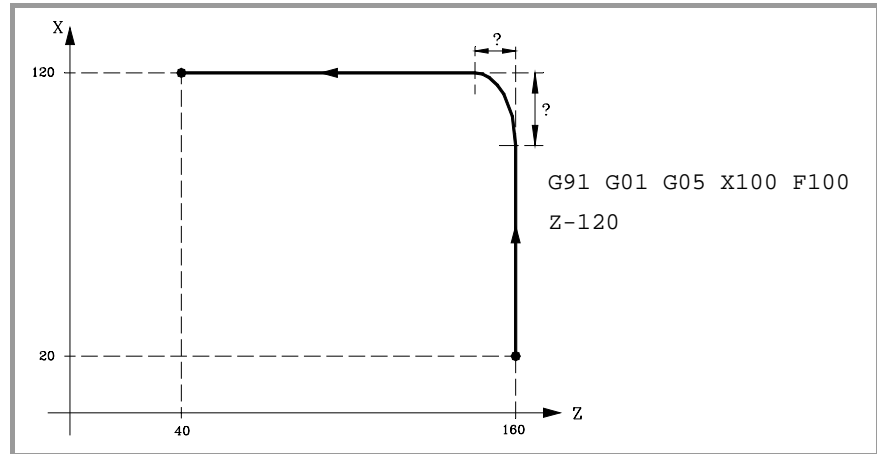

Via this function round corners can be obtained, as shown in the figure.

The difference between the theoretical and real profiles depends on the programmed feedrate value "F". The higher the feedrate, the greater the difference between both profiles.

Function G05 is modal and incompatible with G07, G50 and G51. Function G05 can be programmed as G5.

On power-up, after executing M02, M30 or after EMERGENCY or RESET, the CNC assumes code G05 or G07 depending on how the general machine parameter "ICORNER" is set.

7.

ADDITIONAL PREPARATORY FUNCTIONS
Working with square (G07) and round (G05, G50) corners



CNC 8055
CNC 8055i

.T- MODEL
(SOFT V16.1x)

7.3.3 Controlled round corner (G50)

When working in G50 (controlled round corner); once the theoretical interpolation of the current block has concluded, the CNC waits for the axis to enter the area defined by machine parameter "INPOSW2" and it then starts executing the following block of the program.

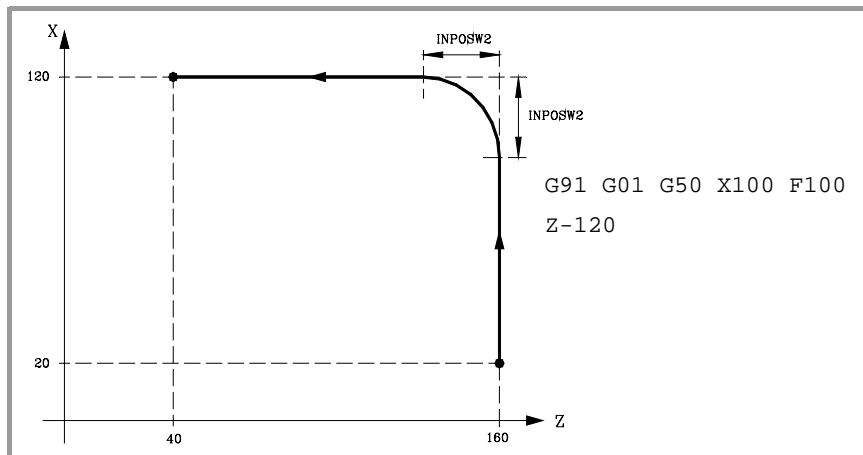

Function G50 assures that the difference between the theoretical and actual paths stays smaller than what was set by machine parameter "INPOSW2".

On the other hand, when working in G05, the difference between the theoretical and real profiles depends on the programmed feedrate value "F". The higher the feedrate, the greater the difference between both profiles.

Function G50 is modal and incompatible with G07, G05 and G51.

On power-up, after executing M02, M30 or after EMERGENCY or RESET, the CNC assumes code G05 or G07 depending on how the general machine parameter "ICORNER" is set.

7.

ADDITIONAL PREPARATORY FUNCTIONS
Working with square (G07) and round (G05, G50) corners



CNC 8055
CNC 8055i

·T· MODEL
(SOFT V16.1X)

7.4 Look-ahead (G51)

7.

ADDITIONAL PREPARATORY FUNCTIONS
Look-ahead (G51)

Programs consisting of very small movement blocks (CAM, etc.) tend to run very slowly. With look-ahead, high speed machining is possible for this type of programs.

The look-ahead function analyzes in advance the path to be machined (up to 75 blocks) in order to calculate the maximum feedrate for each section of the path. This function provides smoother and faster machining in programs with very small movements, even in the order of microns.

It is recommended to have the CPU-TURBO option when using the look-ahead function.

When operating with "Look-Ahead", it is a good idea to adjust the axes so their following error (lag) is as small as possible because the contouring error will be at least equal to the minimum following error.

Programming format.

The programming format is:

G51 [A] E B

- | | |
|-----------|---|
| A (0-255) | Is optional and it defines the percentage of acceleration to be applied.
When not programmed or programmed with a "0" value, the CNC assumes the acceleration value set by machine parameter for each axis. |
| E (5.5) | Maximum contouring error.
The lower this parameter value is, the lower the machining feedrate will be. |
| B (0-180) | It makes it possible to machine square corners using the Look-ahead function.
It indicates the angular value (in degrees) of the programmed corners, below which, the machining operation will be carried out in square corner mode. |

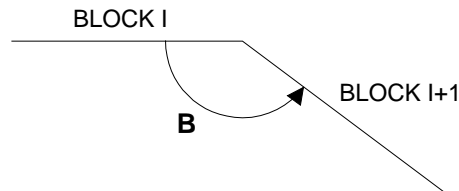

Parameter "A" permits using a standard working acceleration and another one to be used when executing with Look-Ahead.

If parameter "B" is not programmed, the square corner management at the corners is canceled.

The square-corner management at the corners is valid for the look-ahead algorithm with jerk management and for the look-ahead algorithm without jerk management.

Considerations for the execution.

When calculating the feedrate, the CNC takes the following into account:

- The programmed feedrate.
- The curvature and the corners.
- The maximum feedrates of the axes.
- The maximum accelerations.



CNC 8055
CNC 8055i

.T- MODEL
(SOFT V16.1X)

If any of the circumstances listed below occurs while executing with Look-Ahead, the CNC slows down to "0" at the previous block and it recovers the machining conditions for Look-Ahead in the next motion block.

- Motionless block.
- Execution of auxiliary functions (M, S, T).
- Single block execution mode.
- MDI mode.
- Tool inspection mode.

If a Cycle Stop, Feed-Hold, etc. occurs while executing in Look-Ahead mode, the machine may not stop at the current block, several additional blocks will be necessary to stop with the permitted deceleration.

To prevent motionless blocks from causing a square-corner effect, change bit 0 of general machine parameter MANTFCON (P189).

Function properties.

Function G51 is modal and incompatible with G05, G07 and G50. Should any of them be programmed, function G51 will be canceled and the new one will be selected.

Function G51 must be programmed alone in a block and there must be no more information in that block.

On power-up, after executing an M02, M30, or after an EMERGENCY or RESET, the CNC will cancel G51, if it was active, and it will assume G05 or G07 according to the setting of general machine parameter "ICORNER".

On the other hand, the CNC will issue Error 7 (Incompatible G functions) when programming any of the following functions while G51 is active:

G33	Electronic threading (G33)
G34	Variable-pitch threading.
G52	Move to hardstop.
G95	Feedrate per revolution.

7.

ADDITIONAL PREPARATORY FUNCTIONS
 Look-ahead (G51)



**CNC 8055
CNC 8055i**

·T· MODEL
(SOFT V16.1X)

7.4.1 Advanced look-ahead algorithm (integrating Fagor filters)

This mode is indicated when machining accuracy is required, especially if Fagor filters have been set for the axes by machine parameters.

The advanced look-ahead algorithm calculates the feedrates at the corners so as to take the effect of those filters into consideration. When programming G51 E, the contouring errors when machining corners will be closer to the value programmed in that G51 function depending on the filters.

To activate the advanced look-ahead algorithm, use bit 15 of g.m.p. LOOKATYP (P160).

Considerations

- If there are no Fagor filters set by machine parameters in the axes of the main channel, activating the advanced look-ahead algorithm will internally activate FIR filters of the 5th order and a frequency of 30 Hz in all the axes of the channel.
- If there are Fagor filters set by machine parameters, activating the advanced look-ahead algorithm will keep the values of those filters as long as their frequency is not higher than 30Hz

If their frequency is higher than 30 Hz, it will assume the values of 5th order and a frequency of 30 Hz.

If there are several filters defined in the axes of the channel, the one with the lowest frequency will be assumed as long as it is not higher than 30Hz.

- Even if the advanced look-ahead algorithm (using Fagor filters) is active with bit 15 of g.m.p. LOOKATYP (P160), it will not start working in the following cases:
 - If g.m.p. IPOTIME (P73) = 1.
 - If a.m.p. SMOTIME (P58) of any of the axes of the main channel is other than 0.
 - If any of the axes of the main channel has defined by parameter a non-Fagor type filter, a.m.p. TYPE (P71) is other than 2.

In these cases, when activating G51, the CNC will issue the corresponding error message.

7.

ADDITIONAL PREPARATORY FUNCTIONS
Look-ahead (G51)



CNC 8055
CNC 8055i

.T- MODEL
(SOFT V16.1x)

7.4.2 Look-ahead operation with Fagor filters active

This option makes it possible to use Fagor filters with Look-ahead (not advanced look-ahead algorithm). It will only be considered if the advanced look-ahead algorithm is deactivated; that is, if bit 15 of g.m.p. LOOKATYP (P160) = 0.

To activate/deactivate this option, use bit 13 of g.m.p. LOOKATYP (P160).

Effect of Fagor filters when machining circles

When machining circles, the error will be smaller when using Fagor filters than without using these filters:

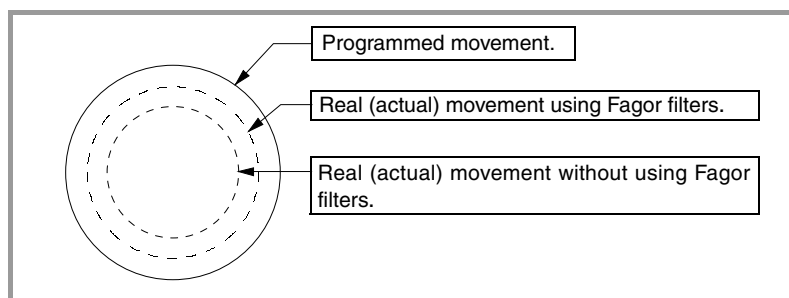

7.4.3 Smoother machining feedrate

Depending on the CNC processing power (that depends on the model and its parameter settings), and depending on the type of part being executed, it activates the management of the smoothing of the F (machining feedrate) to keep it stable. This helps achieve smoother machining in programs that demand high calculating power (programs with very small blocks and high programmed feedrate).

This option is valid for any look-ahead algorithm. Use bit 14 of general machine parameter LOOKATYP (P160) to activate it.



If this option is activated with look-ahead algorithm with jerk management (bit 0 of g.m.p. LOOKATYP (P160)=1), it is not necessary to set general machine parameter TLOOK (P161).

7.

ADDITIONAL PREPARATORY FUNCTIONS
Look-ahead (G51)

FAGOR

CNC 8055
CNC 8055i

·T· MODEL
(SOFT V16.1X)

7.5 Mirror image (G10, G11, G12, G13, G14)

The functions to activate the mirror image are the following.

- G10: Cancel mirror image.
- G11: Mirror image on X axis
- G12: Mirror image on Y axis.
- G13: Mirror image on Z axis
- G14: Mirror image on any axis (X..C), or in several at the same time.

Examples:

- G14 W
- G14 X Z A B

When the CNC works with mirror images, it executes the movements programmed in the axes that have mirror image selected, with the sign changed.

The following subroutine defines the machining of part "A".

```
G90 G00 X40 Z150
G02 X80 Z110 R60
G01 Z60
X120 Z0
```

The programming of all parts would be :

```
Execution of subroutine ; machines "A".
G13 ; Mirror image on Z axis.
Execution of subroutine ; machines "B"
M30 ; End of program
```

Functions G11, G12, G13, and G14 are modal and incompatible with G10.

G11, G12, and G13 can be programmed in the same block, because they are not incompatible with each other. Function G14 must be programmed alone in the block.

If while one of the mirror imaging functions (G11, G12, G13, and G14) is active, a new coordinate origin (part zero) is preset with G92, this new origin will not be affected by the mirror imaging function.

On power-up, after executing M02, M30 or after EMERGENCY or RESET, the CNC assumes code G10.

7.

ADDITIONAL PREPARATORY FUNCTIONS
Mirror image (G10, G11, G12, G13, G14)



CNC 8055
CNC 8055i

.T- MODEL
(SOFT V16.1x)

7.6 Scaling factor (G72)

By using function G72 you can enlarge or reduce programmed parts.

In this way, you can produce families of parts which are similar in shape but of different sizes with a single program.

Function G72 should be programmed on its own in a block. There are two formats for programming G72 :

- Scaling factor applied to all axes.
- Scaling factor applied to one or more axes.

7.**ADDITIONAL PREPARATORY FUNCTIONS**
Scaling factor (G72)**FAGOR** **CNC 8055
CNC 8055i**·T· MODEL
(SOFT V16.1X)

7.6.1 Scaling factor applied to all axes

The programming format is:

G72 S5.5

Following G72 all coordinates programmed are multiplied by the value of the scaling factor defined by S until a new G72 scaling factor definition is read or the definition is cancelled.

7.

ADDITIONAL PREPARATORY FUNCTIONS
Scaling factor (G72)

Example programming the X axis in diameter.

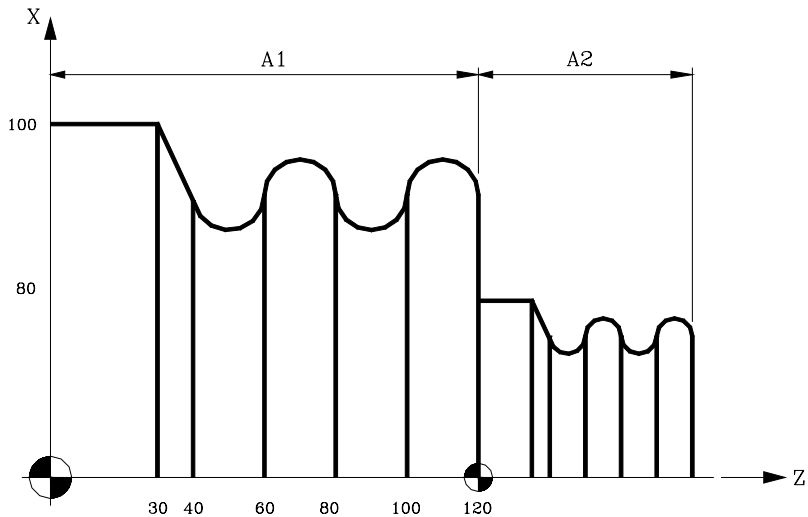

The following subroutine defines the basic machining operation.

```
G90 X200 Z0
G01 X200 Z30 F150
G01 X160 Z40
G03 X160 Z60 I0 J10
G02 X160 Z80 I0 J10
G03 X160 Z100 I0 J10
G02 X160 Z120 I0 J10
```

The programming of the parts would be :

Execution of subroutine Machines "A1".

```
G92 Z0 ; Coordinate preset
; (zero offset)
```

```
G72 S0.5 ; Applies a scaling factor of 2
```

Execution of subroutine Machines "A2".

```
G72 S1 ; Cancel the scaling factor
M30 ; End of program
```

Function G72 is modal and is cancelled when another scaling factor with a value of S1 is programmed, or on power-up, after executing M02, M30 or after EMERGENCY or RESET.



CNC 8055
CNC 8055i

.T- MODEL
(SOFT V16.1x)

7.6.2 Scaling factor applied to one or more axes

The programming format is:

```
G72 X...C 5.5
```

After G72 the axis or axes and the required scaling factor are programmed.

All blocks programmed after G72 are treated by the CNC as follows :

1. The CNC calculates the movement of all the axes in relation to the programmed path and compensation.
2. It then applies the scaling factor indicated to the calculated movement of the corresponding axis or axes.

If the scaling factor is applied on one or more axes, the CNC will apply the scaling factor indicated both to the movement of the corresponding axis or axes and to their feedrate.

If, within the same program, both scaling factor types are applied, the one applied to all the axes and the one for one or several axes, the CNC applies a scaling factor equal to the product of the two scaling factors programmed for this axis to the axis or axes affected by both types.

Function G72 is modal and will be cancelled when the CNC is turned on, after executing M02, M30 or after an EMERGENCY or RESET.



This type of scaling factor is ignored when simulating without moving the axes.

Application of the scaling factor to the Z axis, working with tool radius compensation.

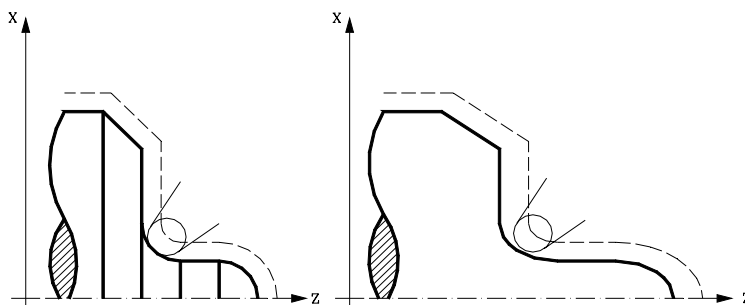

As it can be observed, the tool path does not coincide with the required path, as the scaling factor is applied to the calculated movement.

7.

ADDITIONAL PREPARATORY FUNCTIONS

Scaling factor (G72)

FAGOR

CNC 8055
CNC 8055i

·T· MODEL
(SOFT V16.1x)

If a scaling factor equal to $360/2\pi R$ is applied to a rotary axis, R being the radius of the cylinder on which you wish to machine, this axis can be considered linear, and any figure with tool radius compensation can be programmed on the cylindrical surface.

7.

ADDITIONAL PREPARATORY FUNCTIONS
Scaling factor (G72)

Example programming the X axis in diameter, assuming that the radius used to make the groove on the cylinder is R20.

Scaling factor to apply = $360/(2\pi R) = 2.86$

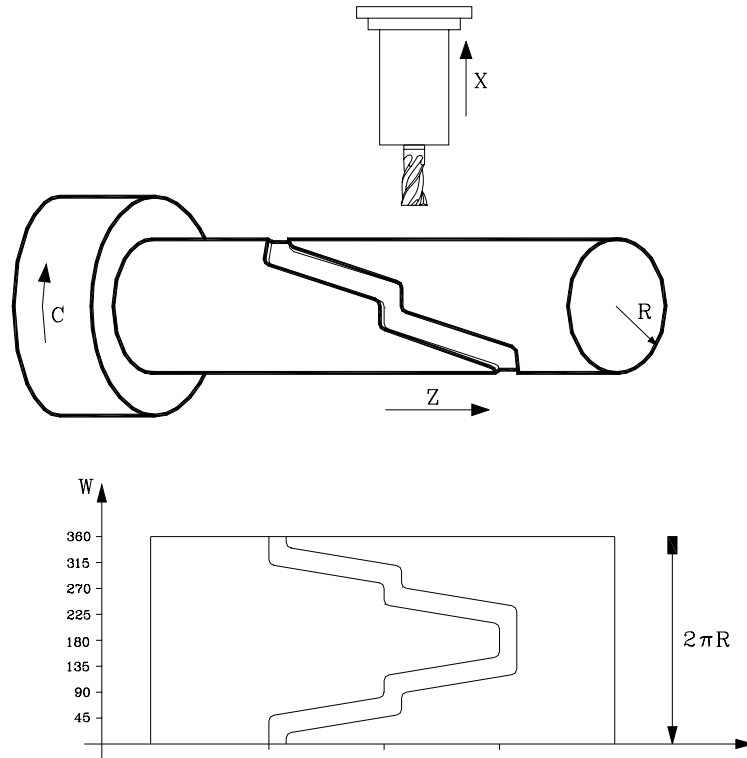

```

G16 ZC
G90 G42 G01 Z70 C0 ; Positioning at starting point
G91 X-4 ; Penetration
G72 C2.86 ; Scaling factor
G90 G36 R5 C45
G36 R5 Z130 C90
G36 R5 C112.5
G36 R5 Z190 C157.5
G36 R5 C202.5
G36 R5 Z130 C247.5
G36 R5 C270
G36 R5 Z70 C315
G36 R5 C360
G91 X4 ; Withdrawal
G72 C1 ; Cancels the scaling factor
M30
    
```



CNC 8055
CNC 8055i

.T- MODEL
(SOFT V16.1x)

7.7 Electronic axis coupling/uncoupling

The CNC enables two or more axes to be coupled together. The movement of all axes is subordinated to the movement of the axis to which they were coupled.

There are three possible ways of coupling axes :

- Mechanical coupling. This is imposed by the manufacturer of the machine, and is selected via the axis machine parameter "GANTRY".
- By PLC. This enables the coupling and uncoupling of each axis through logic input on the CNC "SYNCHRO1", "SYNCHRO2", "SYNCHRO3", "SYNCHRO4", and "SYNCHRO5". Each axis is coupled to the one indicated in the axis machine parameter "SYNCHRO".
- By program. This enables electronic coupling and uncoupling between two or more axes, through functions G77 and G78.

7.7.1 Electronic axis coupling, slaving, (G77)

Function G77 allows the selection of both the master axis and the slaved axis (axes). The programming format is as follows :

```
G77 <Axis 1> <Axis 2> <Axis 3> <Axis 4> <Axis 5>
```

Where <Axis 2>, <Axis 3>, <Axis 4> and <Axis 5> will indicate the axes to be coupled to <Axis 1>. You have to define <Axis 1> and <Axis 2>, the programming of the rest of the axes being optional.

Example:

```
G77 X Y U ; Couples the Y and U axes to the X axis
```

The following rules should be observed when slaving axes electronically:

- You may use one or two different electronic couplings.

```
G77 X Y U ; Couples the Y and U axes to the X axis
```

```
G77 V Z ; Couples the Z axis to the V axis.
```
- You cannot couple one axis to two others at the same time.

```
G77 V Y ; Couples the Y axis to the V axis.
```

```
G77 X Y ; Gives an error signal, because the Y axis is coupled to the V axis.
```
- You can couple several axes to one in successive steps.

```
G77 X Z ; Couples the Z axis to the X axis.
```

```
G77 X U ; Couples the U axis to the X axis → Z U coupled to X.
```

```
G77 X Y ; Couples the Y axis to the X axis → Y Z U coupled to X.
```
- A pair of axes which are already coupled to each other cannot be coupled to another axis.

```
G77 Y U ; Couples the U axis to the Y axis.
```

```
G77 X Y ; Issues an error because Y axis is coupled to U axis.
```

7.

ADDITIONAL PREPARATORY FUNCTIONS
Electronic axis coupling/uncoupling

FAGOR 

CNC 8055
CNC 8055i

.T- MODEL
(SOFT V16.1X)

7.8 Axes toggle G28-G29

With this feature, on vertical lathes having two turrets or on machines having 2 spindles, it is possible to use a single part-program to make different parts.

With function G28 the axes can be toggled from one to the other in such way that after that instruction all the movements associated with the first axis next to G28 will take place on the second axis next to G28 and vice versa.

Programming format:

```
G28 (axis 1) (axis 2)
```

To cancel the toggle, execute function G29 followed by one of the axes to be toggled back. Up to three pairs of axes may be toggled at the same time.

The main axes cannot be toggled while the C axis is active on a lathe.

On power-up, after executing M30 or following an emergency or a reset, the axes are toggled back.

The next example shows how to use this feature on a dual-spindle lathe. The part program is defined for spindle 1.

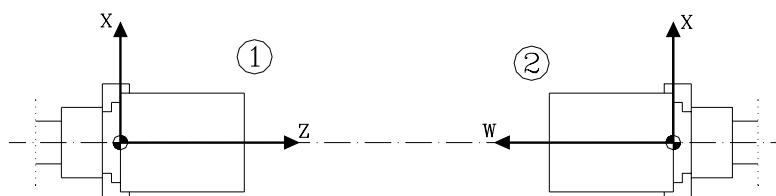

1. Execute the part-program at spindle 1.
2. G28 ZW. Toggle the ZW axes.
3. Select spindle 2.
4. Zero offset to machine at spindle 2.
5. Execute the part-program.
 - It will be executed at spindle 2.
 - In the meantime, replace the part made on table 1 with a new one.
6. G29 Z. Toggle the ZW axes back.
7. Select spindle 1.
8. Cancel zero offset to machine on table 1.
9. Execute the part-program.
 - It will be executed on table 1.
 - In the meantime, replace the part made on table 2 with a new one.

7.

ADDITIONAL PREPARATORY FUNCTIONS
Axes toggle G28-G29

FAGOR 

CNC 8055
CNC 8055i

·T· MODEL
(SOFT V16.1x)

7.

ADDITIONAL PREPARATORY FUNCTIONS

Axes toggle G28-G29



CNC 8055
CNC 8055i

.T- MODEL
(SOFT V16.1X)

8.1 Tool length compensation

It is always applied to compensate for the length difference between the various tools programmed.

When selecting a new tool, the CNC takes its dimensions into account, defined in the corresponding offset and moves the tool holding turret so the new tool occupies the same position (coordinate) as the previous one.

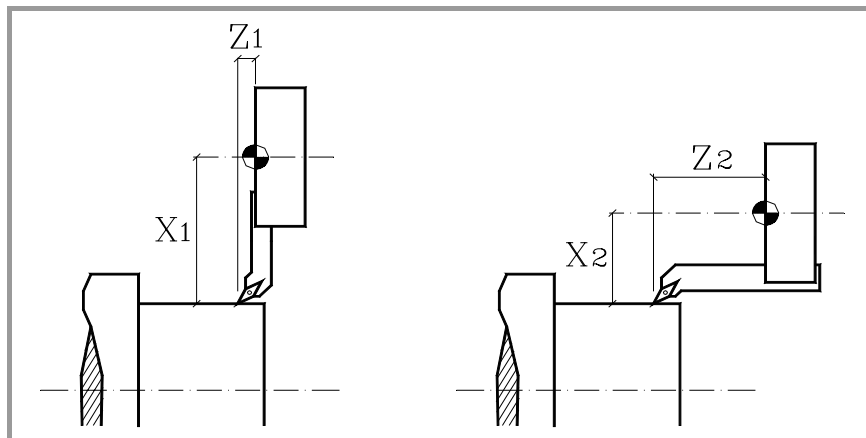

8.2 Tool radius compensation

It must be programmed. The CNC assumes as theoretical tip (P) the result of the sides used when calibrating the tool (left figure). Without radius compensation, the theoretical tip (P) travels the programmed path (center figure) leaving machining ridges.

With tool radius compensation, it takes into account the radius of the tip (nose) and the location code or tool type which results in the proper dimensions of the programmed part (right figure).

8.

TOOL COMPENSATION
Tool radius compensation

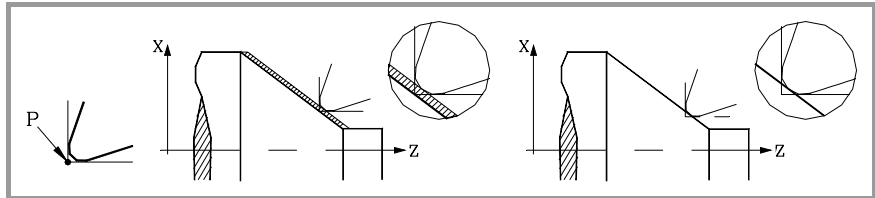

The CNC always shows the position of the theoretical tip. Therefore, when using tool radius compensation, the coordinates and the graphic representation do not always coincide with the programmed path.

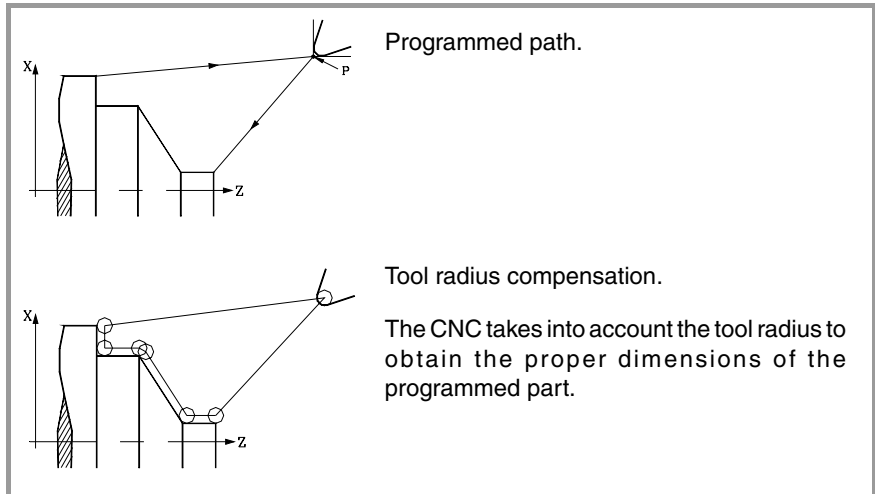

The CNC does not show the tool center path; it shows the position of the theoretical tip.

The path of the theoretical tip coincides, in part, with the profile programmed in turning and facing, but never coincides with the incline or curved sections.

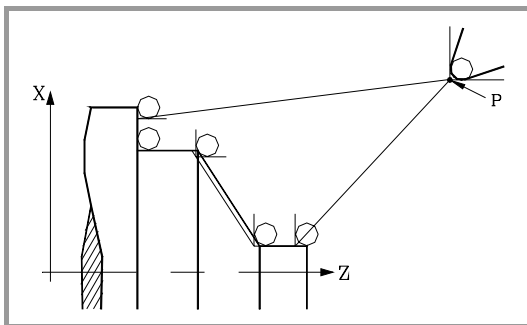

CNC 8055
CNC 8055i

.T- MODEL
(SOFT V16.1x)

8.2.1 The location code of the tool (tool type)

The location code indicates the tool type and the sides used to calibrate it. It depends on the position of the tool and the orientation of the axes on the machine.

The following example shows the location code F3 on different machines. Observe how the relative tool position is maintained with respect to the axes.

Horizontal lathes

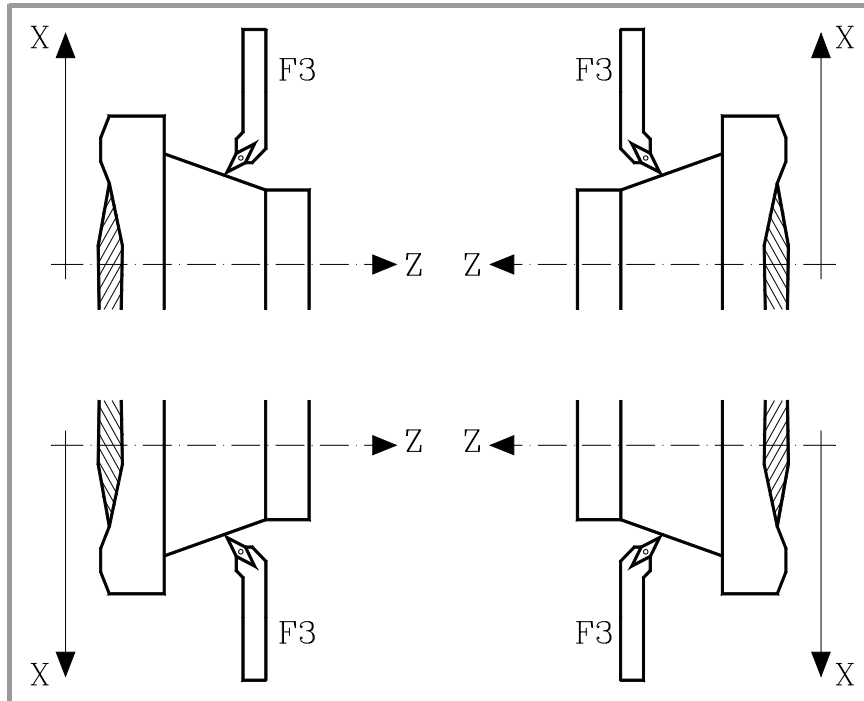

Vertical lathes

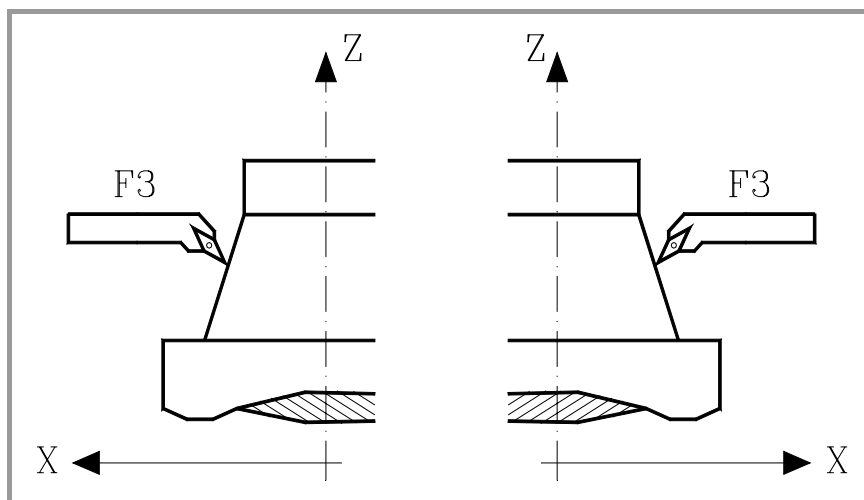

8.

TOOL COMPENSATION
Tool radius compensation

FAGOR 

CNC 8055
CNC 8055i

·T· MODEL
(SOFT V16.1x)

We now show the location codes available on the most common horizontal lathes.

8.

TOOL COMPENSATION

Tool radius compensation

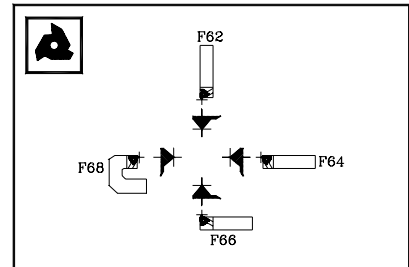
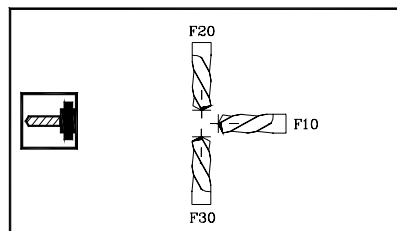
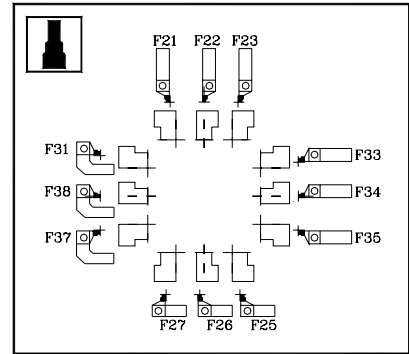
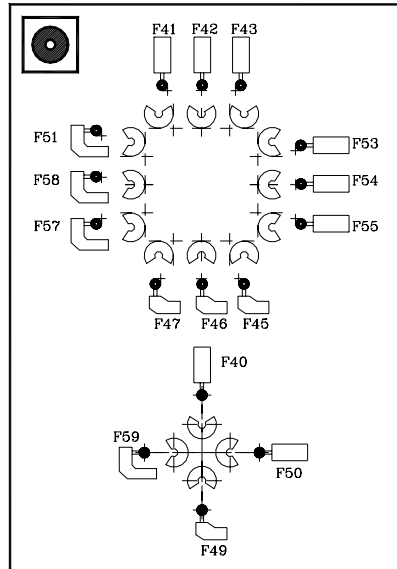
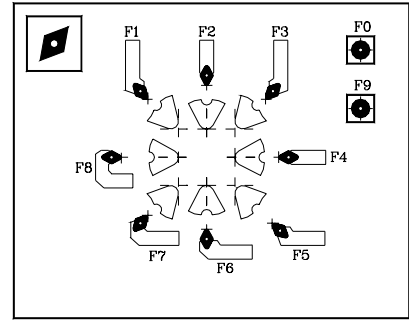
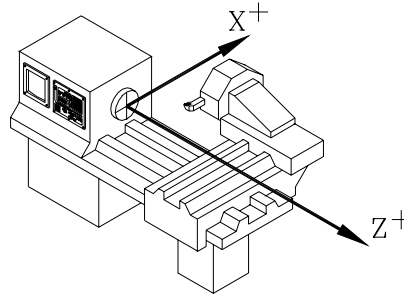

CNC 8055
CNC 8055i

.T- MODEL
(SOFT V16.1x)

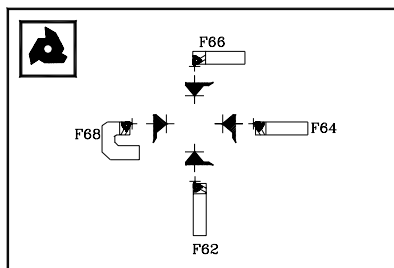
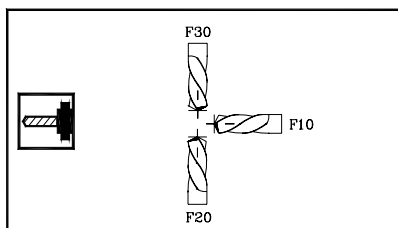
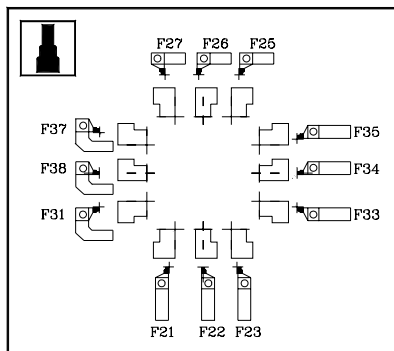
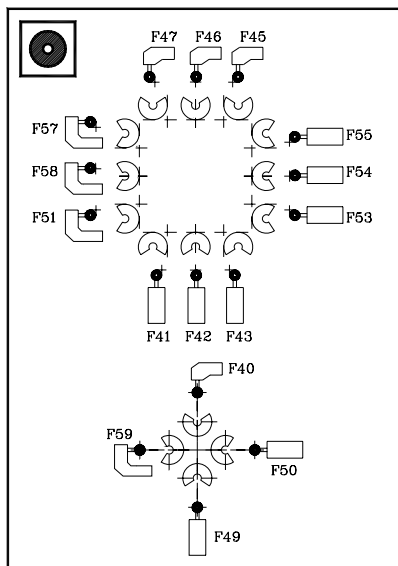
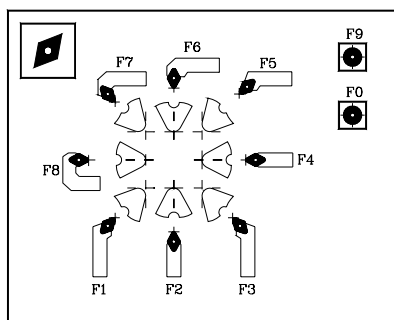
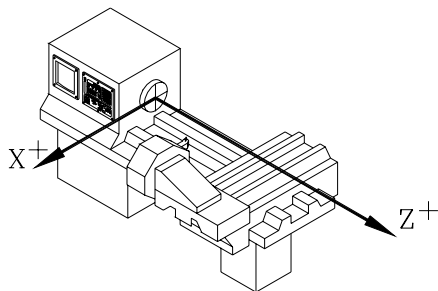

8.

TOOL COMPENSATION
Tool radius compensation



CNC 8055
CNC 8055i

·T· MODEL
(SOFT V16.1X)

8.2.2 Working without tool radius compensation

There are certain limitations to work without tool radius compensation.

Tool location code (tool type).

Only tools that have been calibrated by touching two of its sides may be used, location codes F1, F3, F5, F7, etc.

It is not recommend to machine with the rest of the tools because the theoretical tip of the tool travels along the programmed path (the shaded area of the right figure is eliminated).

8.

TOOL COMPENSATION
Tool radius compensation

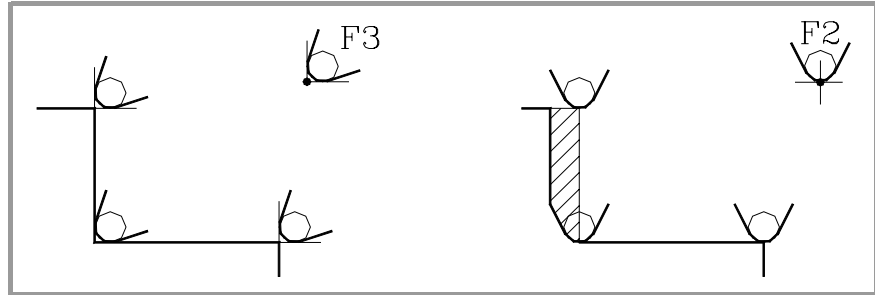

Machining sections.

Only sides with constant diameter may be turned (left figure) or straight walls may be faced (right figure).

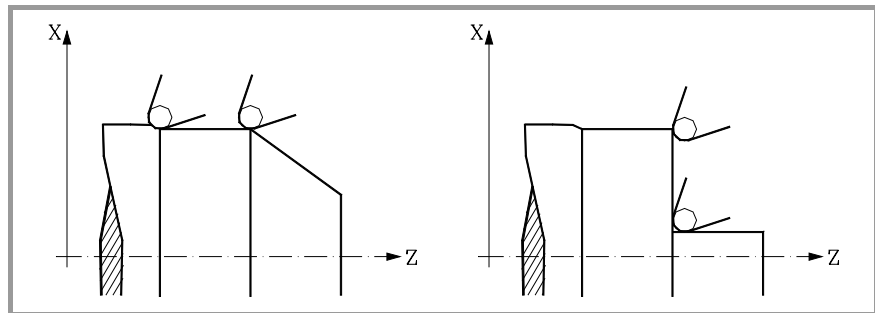

There are problems in incline sections (left figure) and on rounded sides (right figure).

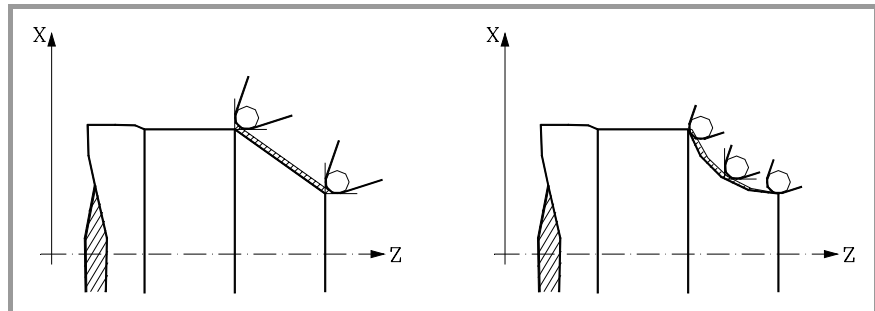

CNC 8055
CNC 8055i

-T- MODEL
(SOFT V16.1x)

Facing straight walls.

When facing to a 0 coordinate (for example from position 40 to 0) the theoretical tip of the tool reaches the 0 coordinate, but due to the tip's rounding, it leaves a ridge on the part. To solve this problem, face to a negative coordinate (for example from 40 to -3).

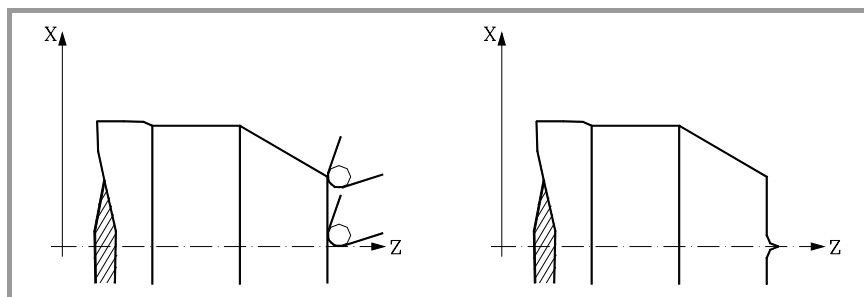

8.

TOOL COMPENSATION
Tool radius compensation

FAGOR 

CNC 8055
CNC 8055i

·T· MODEL
(SOFT V16.1X)

8.2.3 Working with tool radius compensation

When working with tool radius compensation, it takes into account the radius of the tip (nose) and the location code or tool type stored in the tool offset table that corresponds to the tool to obtain the proper dimensions of the programmed part.

All the tools have an associated offset (in the tool table). Use the "D" code to select another offset. If no tool offset has been programmed, the CNC applies offset D0, with X=0, Z=0, F=0, R=0, I=0 and K=0.

Tool dimensions can also be defined with the variables TOX, TOZ, TOF, TOR, TOI, TOK.

There are three preparatory functions for tool radius compensation:

- G40 Cancellation of tool radius compensation.
- G41 Tool radius compensation to the left of the part.
- G42 Tool radius compensation to the right of the part.

Functions G41 and G42 are modal and incompatible to each other. They are cancelled by G40, G04 (interruption of block preparation), G53 (programming with reference to machine zero), G74 (home search), G66, G68, G69, G83 (machining canned cycles) and also on power-up, after executing M02, M30 or after and emergency or a reset.

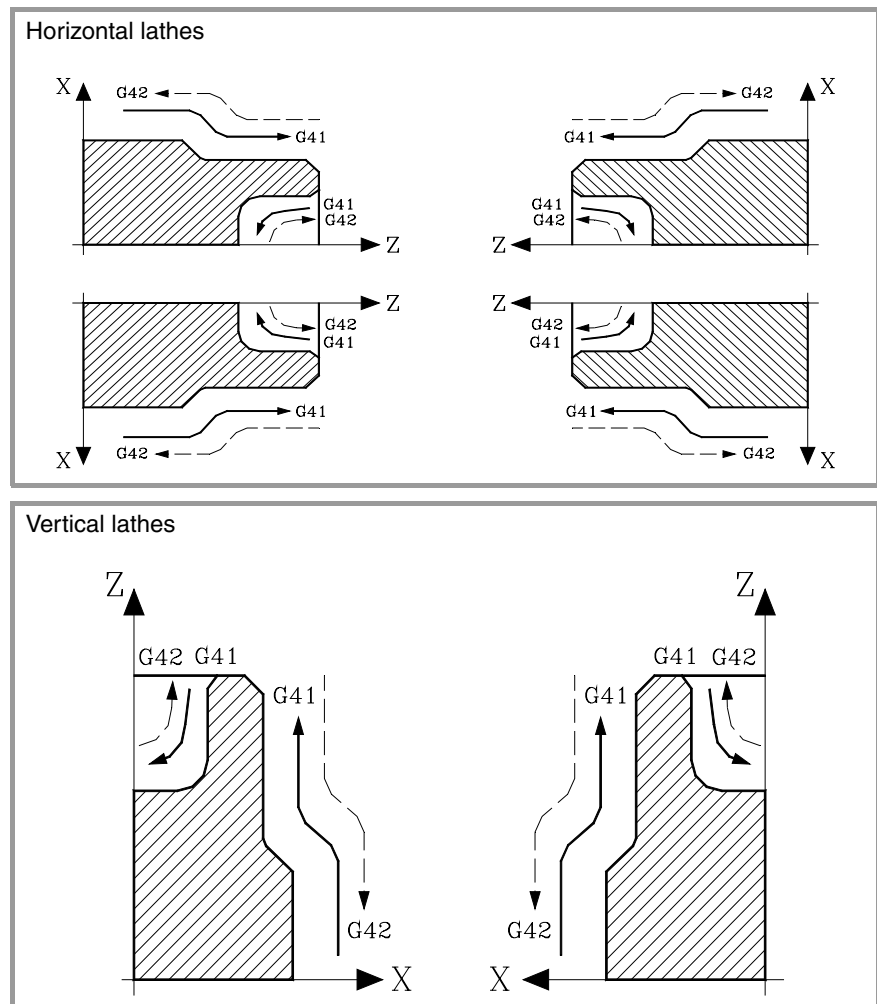

8.

TOOL COMPENSATION

Tool radius compensation



CNC 8055
CNC 8055i

.T- MODEL
(SOFT V16.1x)

8.2.4 Beginning of tool radius compensation (G41, G42)

Once the plane in which tool radius compensation has been selected, functions G41 or G42 must be used to activate it.

- G41 Tool radius compensation to the left of the part.
- G42 Tool radius compensation to the right of the part.

In the same block (or a previous one) in which G41 or G42 is programmed, functions T, D, or only T must be programmed so that the tool offset value to be applied can be selected from the tool offset table. If no tool offset is selected, the CNC takes D0 with X0 Z0 F0 R0 I0 K0.

When the new selected tool has function M06 associated with it and this, in turn, has an associated subroutine, the CNC will first process the motion block of that subroutine as the starting block of the compensation.

If in that subroutine, a block is executed that contains function G53 (programming in machine coordinates), the previously selected G41 or G42 is temporarily canceled in that block.

The selection of tool radius compensation (G41 or G42) can only be made when functions G00 or G01 are active (straight-line movements). If the compensation is selected while G02 or G03 are active, the CNC will display the corresponding error message.

We now show different cases of starting tool radius compensation, in which the programmed path is represented by a thick line and the tool center path with a thin line.

Beginning of compensation without programming a movement

After activating the compensation, it could happen that the plane axes do not get involved in the first motion block either because they have not been programmed or because the same point as the tool position has been programmed or because a null incremental move has been programmed.

In this case, the compensation is applied in the current tool position; depending on the first movement programmed in the plane, the tool moves perpendicular to the path on its starting point.

The first movement programmed in the plane may be either linear or circular.

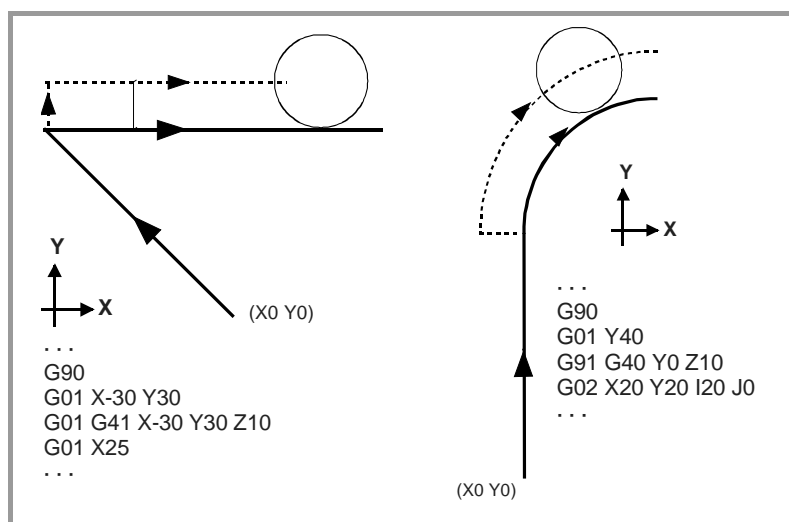

8.

TOOL COMPENSATION
Tool radius compensation



CNC 8055
CNC 8055i

·T· MODEL
(SOFT V16.1x)

STRAIGHT-STRAIGHT path

8.

TOOL COMPENSATION

Tool radius compensation

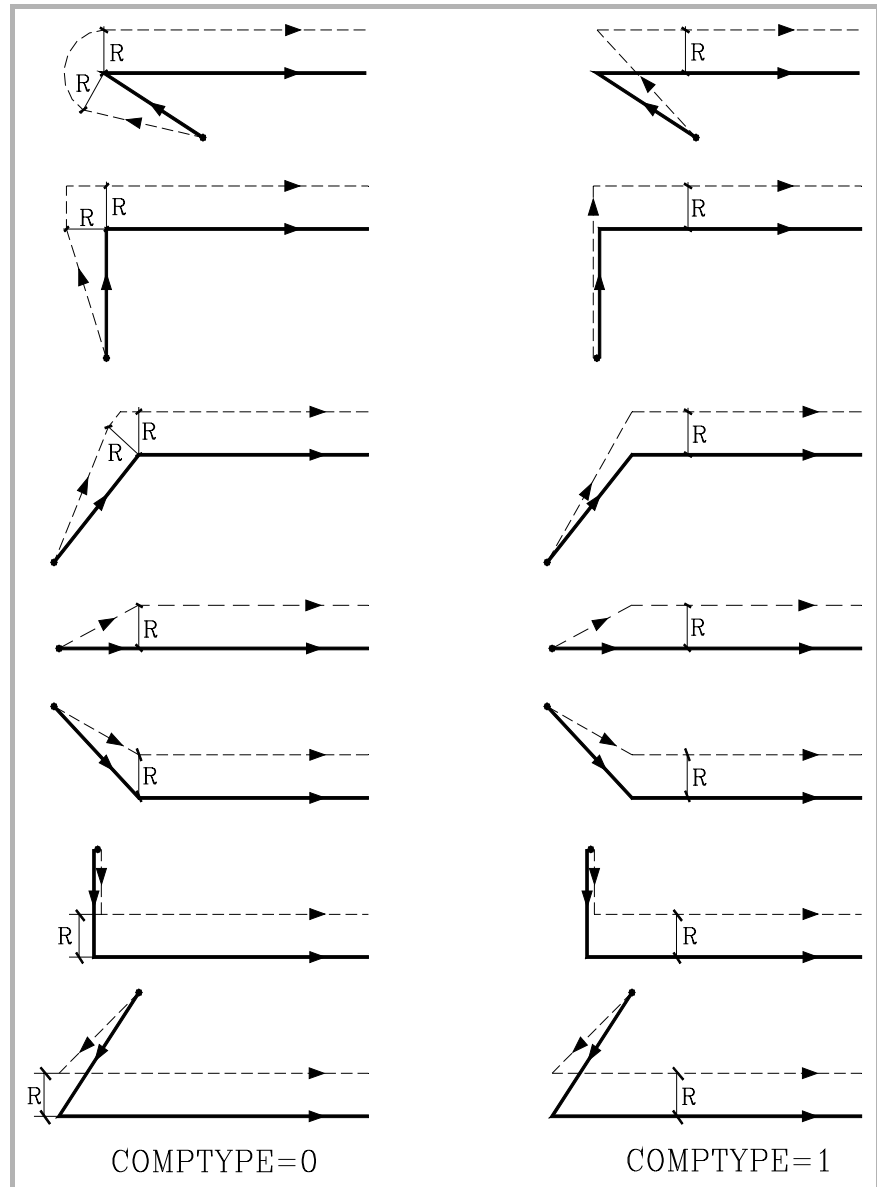

CNC 8055
CNC 8055i

.T- MODEL
(SOFT V16.1X)

STRAIGHT-CURVED path

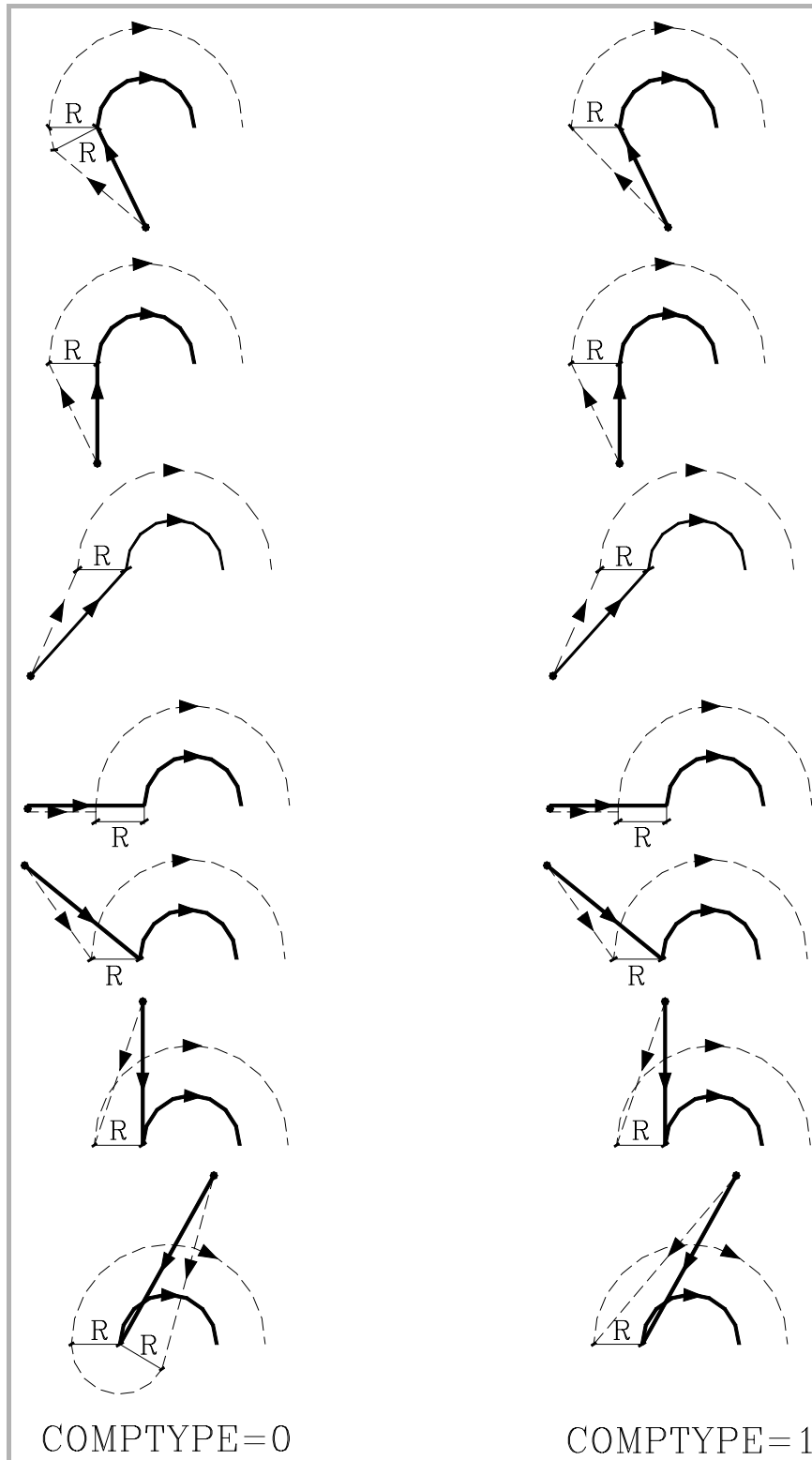

8.

TOOL COMPENSATION
Tool radius compensation



CNC 8055
CNC 8055i

·T· MODEL
(SOFT V16.1x)

8.2.5 Sections of tool radius compensation

The CNC reads up to 50 blocks ahead of the one it is executing, with the aim of calculating beforehand the path to be followed. When working with tool radius compensation, the CNC needs to know the next programmed movement to calculate the path to follow; therefore, no more than 48 blocks can be programmed in a row.

The diagrams (below) show the different paths followed by a tool controlled by a programmed CNC with tool radius compensation. The programmed path is represented by a thick line and the tool center path by a thin line.

8.

TOOL COMPENSATION

Tool radius compensation

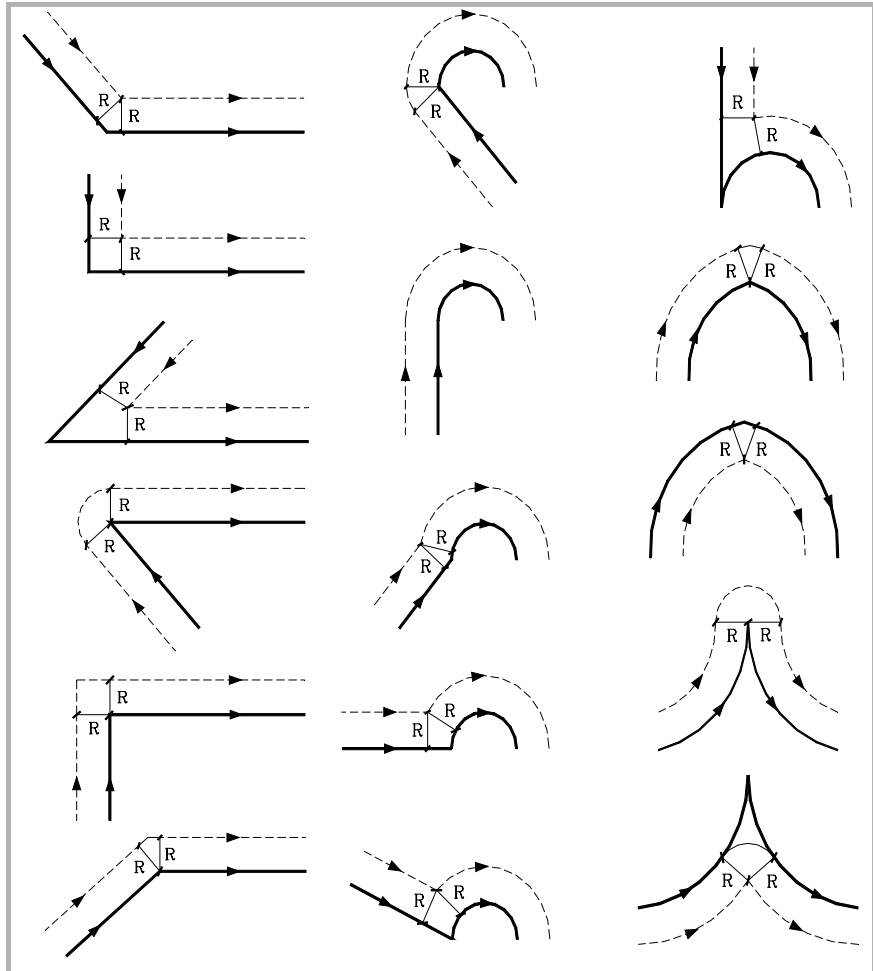

The way the various paths are blended (joined) depends on the setting of machine parameter COMPMODE.

- If it is set to $\cdot 0\cdot$, the compensation method depends on the angle between paths. With an angle between paths of up to 300° , both paths are joined with straight sections. In the rest of the cases, both paths are joined with arcs.
- If it is set to $\cdot 1\cdot$, both paths are joined with arcs.
- If it is set to $\cdot 2\cdot$, the compensation method depends on the angle between paths. With an angle between paths of up to 300° , it calculates the intersection. In the rest of the cases it is compensated like $\text{COMPMODE} = 0$.



CNC 8055
CNC 8055i

·T· MODEL
(SOFT V16.1X)

8.2.6 Cancellation of tool radius compensation (G40)

Tool radius compensation is cancelled by using function G40.

It should be remembered that canceling radius compensation (G40) can only be done in a block in which a straight-line movement is programmed (G00 or G01). If G40 is programmed while functions G02 or G03 are active, the CNC displays the corresponding error message.

We now show different cases of starting tool radius compensation, in which the programmed path is represented by a thick line and the tool center path with a thin line.

End of compensation without programming a movement

After cancelling the compensation, it could happen that the plane axes do not get involved in the first motion block either because they have not been programmed or because the same point as the tool position has been programmed or because a null incremental move has been programmed.

In this case, the compensation is canceled in the current tool position; depending on the last movement executed in the plane, the tool moves to the end point without compensating the programmed path.

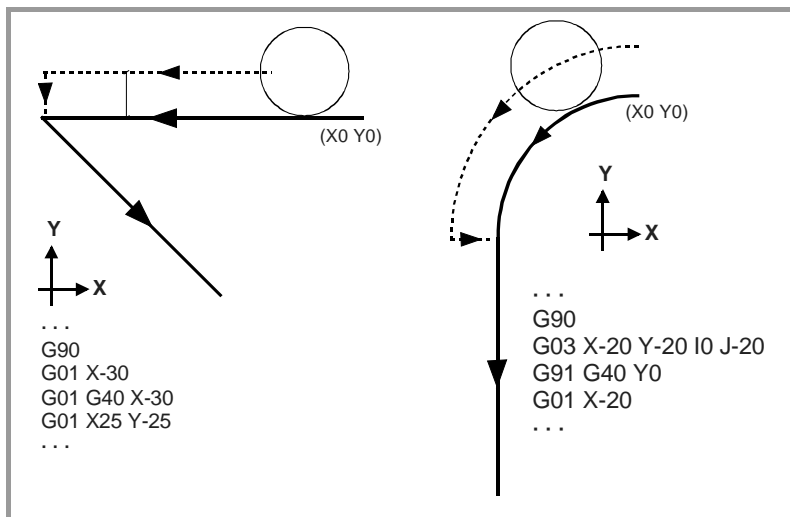

8.

TOOL COMPENSATION
Tool radius compensation

FAGOR 

CNC 8055
CNC 8055i

·T· MODEL
(SOFT V16.1x)

STRAIGHT-STRAIGHT path

8.

TOOL COMPENSATION
Tool radius compensation

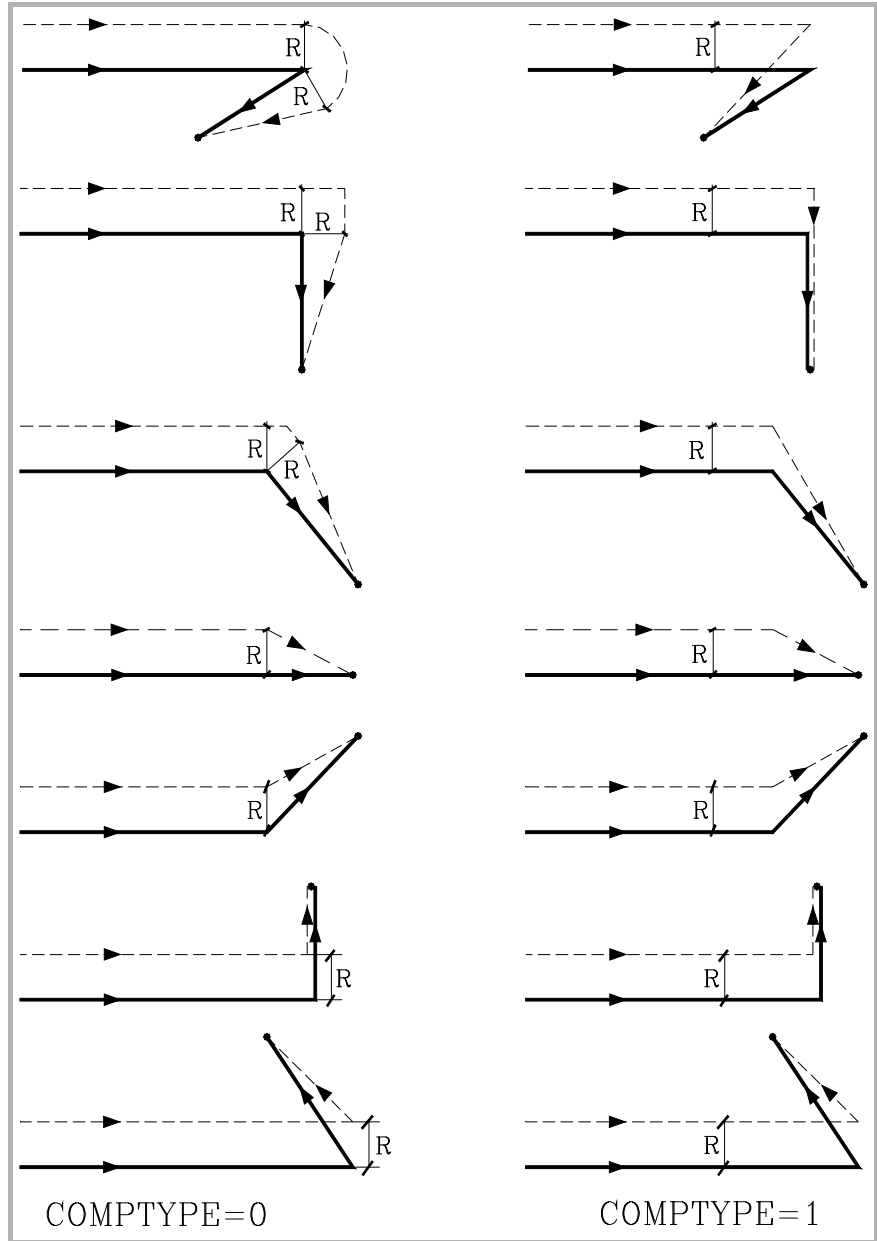

CNC 8055
CNC 8055i

.T- MODEL
(SOFT V16.1x)

CURVED-STRAIGHT path

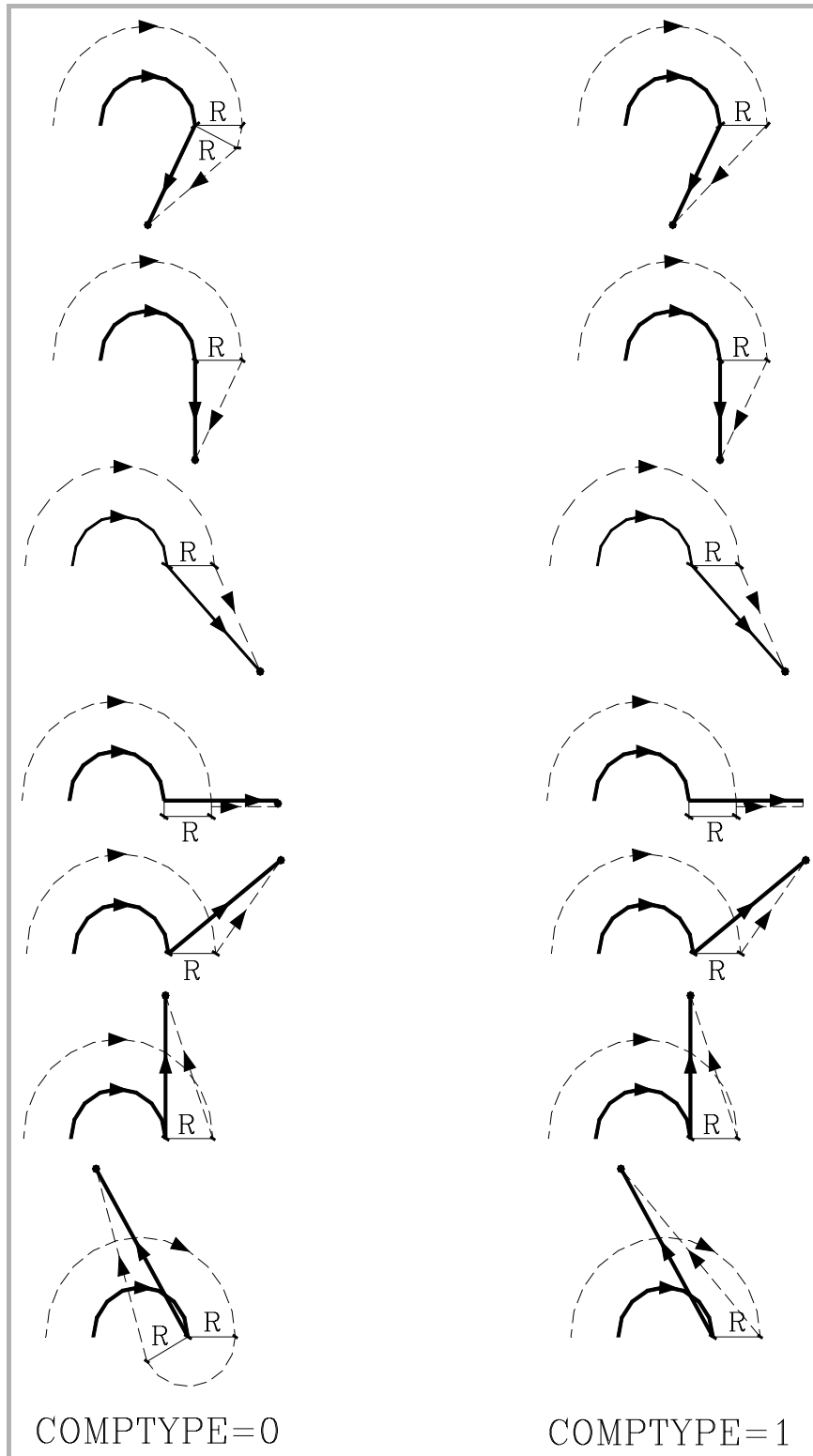

8.

TOOL COMPENSATION
Tool radius compensation



CNC 8055
CNC 8055i

·T· MODEL
(SOFT V16.1x)

Programming example

8.

TOOL COMPENSATION

Tool radius compensation

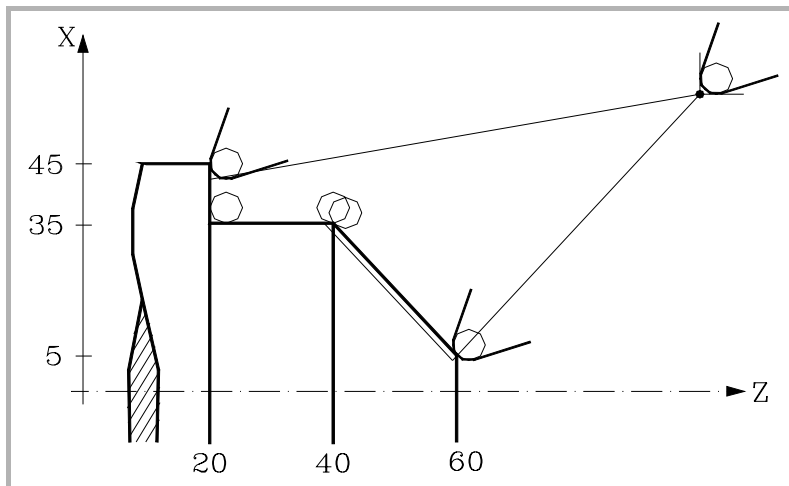

T1 D1

G0 G90 X110 Z100

Positioning at the starting point.

G1 G42 X10 Z60

It activates the compensation and moves to the starting point.

X70 Z40

X70 Z20

X90 Z20

Movement to end point (compensation active).

G40 X110 Z100

It cancels the compensation and moves to the starting point.



CNC 8055
CNC 8055i

.T- MODEL
(SOFT V16.1X)

8.2.7 Temporary cancellation of tool compensation with G00

When detecting a change from G01, G02, G03, G33 to G00, the CNC temporarily cancels tool radius compensation and keeps the tool tangent to the perpendicular at the end of the movement programmed in the block containing G01, G02, G03, G33 or G34.

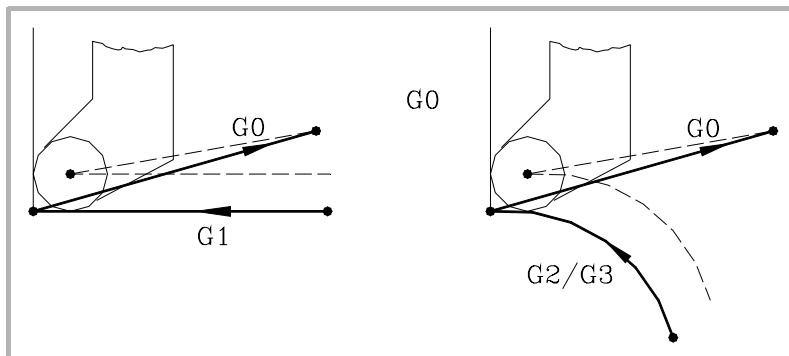

When detecting a change from G00 to G01, G02, G03, G33 or G34, the new block is treated like the first compensated point resuming tool radius compensation.

Special case: If the CNC does not have enough information for compensating, but the movement is in G00, it will execute it without tool radius compensation.

Programming example

Wrong programming example. Compensation is canceled in the last block of the profile and the machining does not coincide with the desired one because the CNC compensates the whole defined section. When compensating the last section, the tool runs into the faced side.

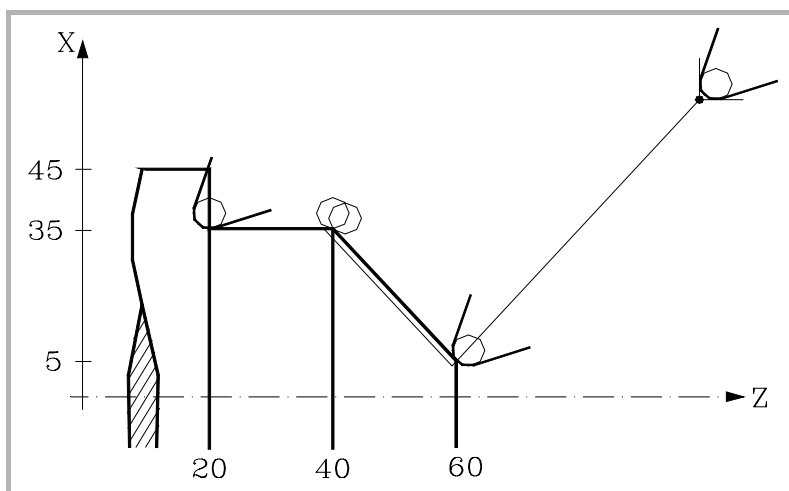

T1 D1

G0 G90 X110 Z100 Positioning at the starting point

G1 G42 X10 Z60 It activates the compensation and moves to the starting point

X70 Z40

X70 Z20

G40 X110 Z100 It cancels the compensation and moves to the starting point



TOOL COMPENSATION
Tool radius compensation



CNC 8055
CNC 8055i

·T· MODEL
(SOFT V16.1x)

This problem is solved using function G00 as described next.

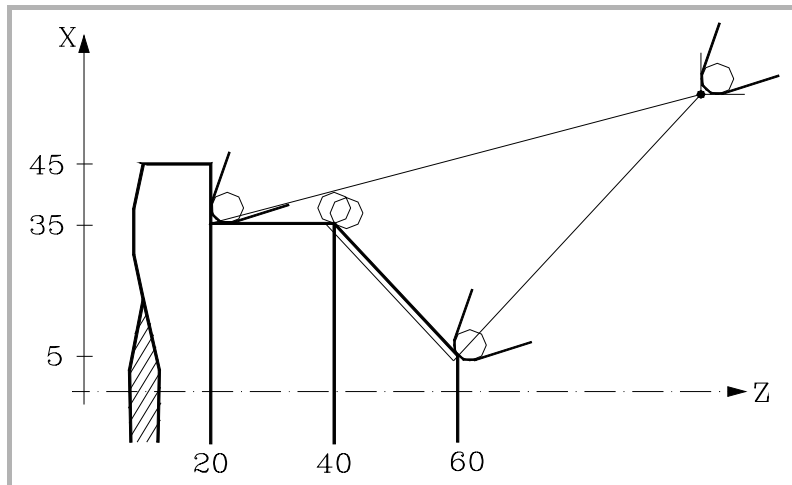

T1 D1

G0 G90 X110 Z100 Positioning at the starting point

G1 G42 X10 Z60 It activates the compensation and moves to the starting point

X70 Z40

X70 Z20

G40 G0 X110 Z100 It cancels the compensation and moves to the starting point

8.

TOOL COMPENSATION

Tool radius compensation



CNC 8055
CNC 8055i

·T· MODEL
(SOFT V16.1x)

8.2.8 Change of type of tool radius compensation while machining

The compensation may be changed from G41 to G42 or vice versa without having to cancel it with G40. It may be changed in any motion block and even in a motionless one, i.e. without moving the axes of the plane or by programming the same point twice.

It compensates independently the last movement before the change and the first one after the change. To change the type of compensation, the different cases are solved according to these criteria:

A. The compensated paths cut each other.

The programmed paths are compensated each on its corresponding side. The change of sides takes place at the intersection point of both paths.

B. The compensated paths do not cut each other.

An additional section is inserted between the two paths. From the point perpendicular to the first path at the end point up to the point perpendicular to the second path at the starting point. Both points are located at a distance R from the programmed path.

Here is a summary of the different cases:

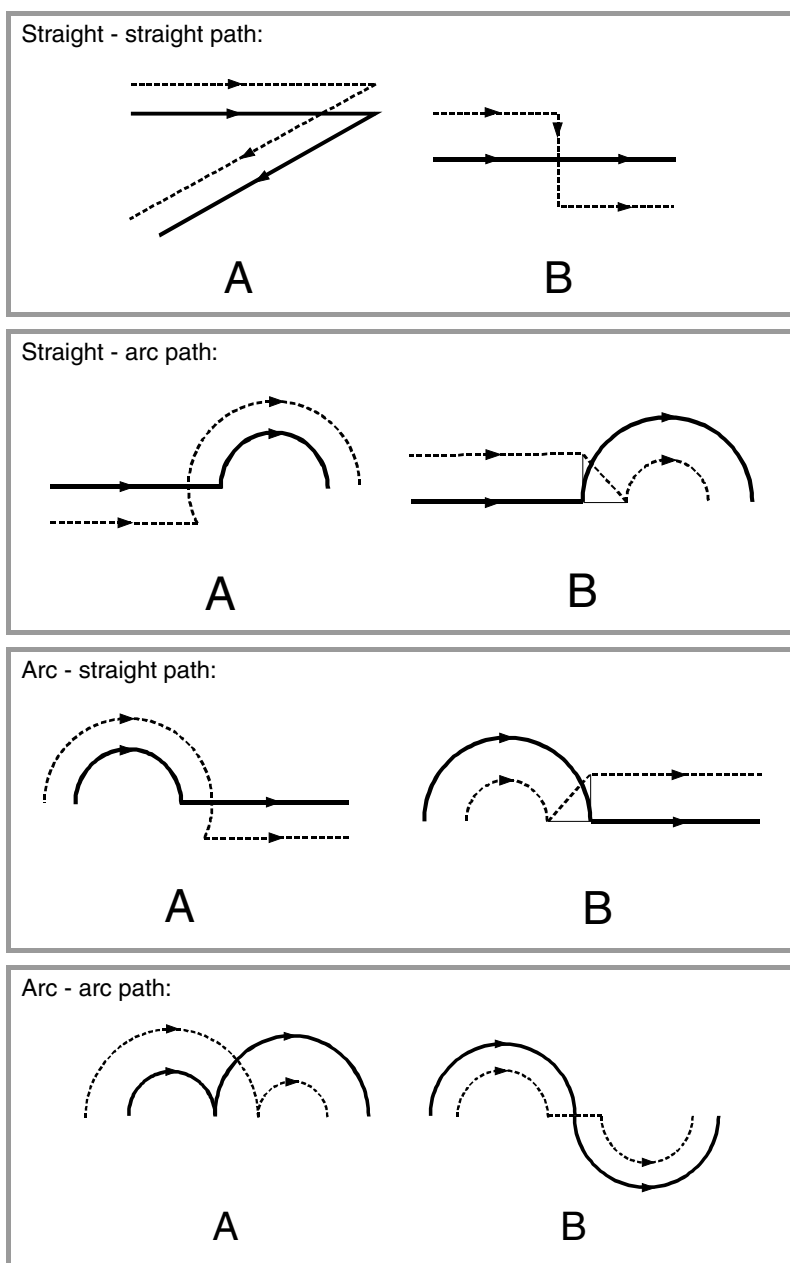

8.

TOOL COMPENSATION
Tool radius compensation



CNC 8055
CNC 8055i

·T· MODEL
(SOFT V16.1x)

8.2.9 Tool compensation in any plane

With general machine parameter "PLACOM", it is possible to use tool compensation either in all planes or just in the ZX plane. When "PLACOM = 1" to apply tool compensation in all planes, the CNC interprets the tool table as follows:

	ZX plane	WX plane	AB plane
Parameters Z and K. Abscissa axis.	Z axis	W axis	A axis
Parameters X and I. Ordinate axis.	X axis	X axis	B axis

8.

TOOL COMPENSATION
Tool radius compensation



CNC 8055
CNC 8055i

.T- MODEL
(SOFT V16.1X)

8.3 Collision detection (G41 N, G42 N)

Using this option, the CNC analyzes in advance the blocks to be executed in order to detect loops (profile intersections with itself) or collisions of the programmed profile. The number of blocks to be analyzed (up to 50) may be defined by the user.

The example shows machining errors (E) due to a collision in the programmed profile. This type of errors may be avoided using collision detection.

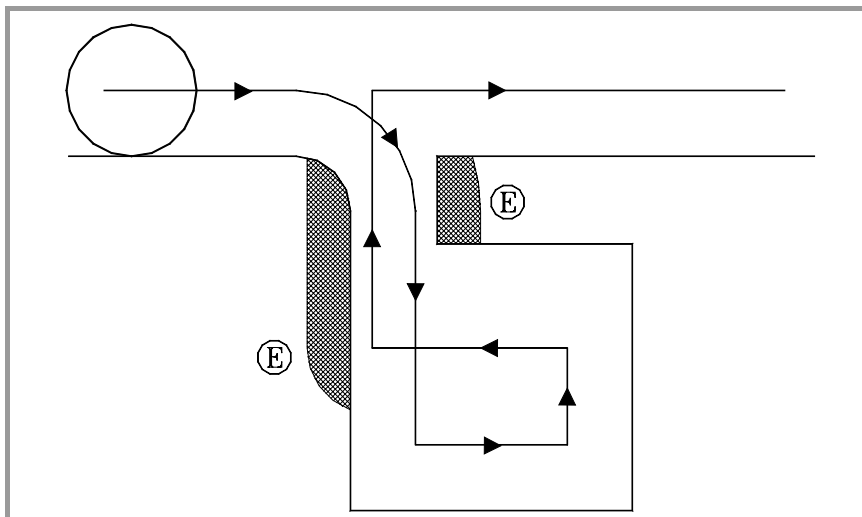

When detecting a loop or a collision, the blocks that caused it will not be executed and a warning will be issued for each loop or collision eliminated.

Possible cases: a step on a straight path, a step in a circular path and tool radius compensation too large.

The information contained in the eliminated blocks, not being the moving in the active plane, will be executed (including the movements of the axes).

Block detection is defined and activated with tool radius compensation functions G41 and G42. A new parameter N (G41 N y G42 N) has been added to activate the feature and define the number of blocks to analyze.

Possible values from N3 to N50. Without "N", or with N0, N1 and N2, it behaves like in older versions.

In CAD generated programs that are made up of lots of very short blocks, it is recommended to use very low N values (around 5) so as not to jeopardize block processing time.

When this function is active, the history of active G functions shows G41 N or G42 N.

8.

TOOL COMPENSATION
Collision detection (G41 N, G42 N)

FAGOR 

CNC 8055
CNC 8055i

·T· MODEL
(SOFT V16.1x)

8.

TOOL COMPENSATION

Collision detection (G41 N, G42 N)



CNC 8055
CNC 8055i

.T- MODEL
(SOFT V16.1X)

This CNC offers the following machining canned cycles:

- G66 Pattern repeat canned cycle.
- G68 X axis roughing canned cycle.
- G69 Z axis roughing canned cycle.
- G81 Turning canned cycle for straight sections.
- G82 Facing canned cycle for straight sections.
- G83 Drilling canned cycle.
- G84 Turning canned cycle for curved sections.
- G85 Facing canned cycle for curved sections.
- G86 Longitudinal threading canned cycle.
- G87 Face threading canned cycle.
- G88 X axis grooving canned cycle.
- G89 Z axis grooving canned cycle.

Machining canned cycles with live tool:

- G60 Face drilling / tapping canned cycle.
- G61 Drilling / tapping canned cycle on the side of the part.
- G62 Slot milling canned cycle on the side of the part.
- G63 Slot milling canned cycle on the face of the part.

A canned cycle is defined by the G function indicating the canned cycle and its corresponding parameters. A canned cycle may be defined anywhere in the program, that is, in the main program as well as in a subroutine.

When working in a plane other than the ZX, for example: G16 WX, the CNC interprets the canned cycle parameters as follows:

	ZX plane	WX plane	AB plane
Parameter Z and all those related to it, with the abscissa axis.	Z axis	W axis	A axis
Parameter Z and all those related to it, with the ordinate axis.	X axis	X axis	B axis



CNC 8055
CNC 8055i

·T· MODEL
(SOFT V16.1X)

9.1 G66. Pattern repeat cycle canned cycle

This cycle machines the programmed profile maintaining the indicated step between consecutive machining passes. Triangular, round and square tools may be used in this cycle.

The basic structure of the block is as follows:

G66 X Z I C A L M H S E Q

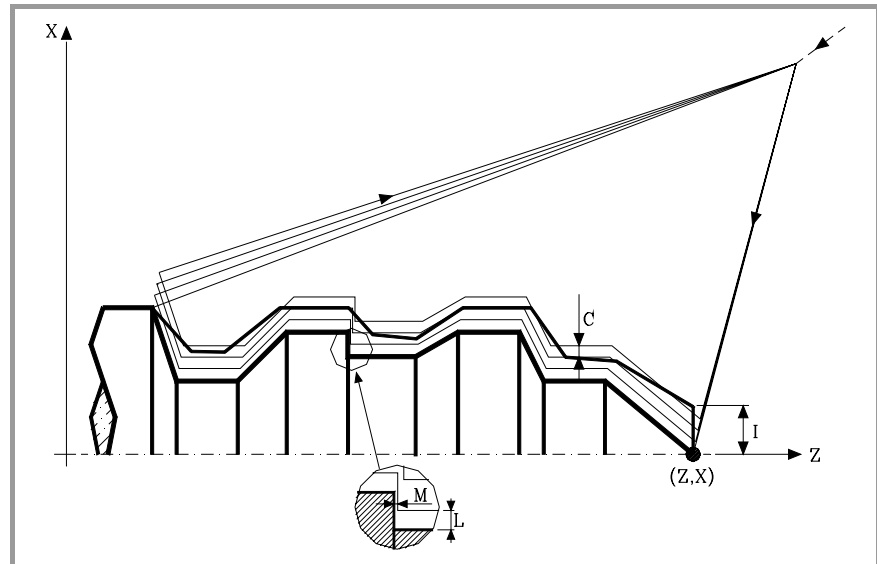

- X±5.5** It sets the X coordinate of the profile's starting point. It must be programmed in absolute coordinates and in the active units, radius or diameter.
- Z±5.5** It sets the Z coordinate of the profile's starting point. It must be programmed in absolute coordinates.
- I5.5** It defines the excess stock to be removed from the original part. It is defined in radius and depending on the value assigned to parameter "A", this value will be interpreted as excess stock in X or in Z.

If its value is not greater than the finishing stock (L or M), it will only run the finishing pass, if H is other than zero.
- C5.5** It defines the machining pass. All the machining passes will be run with this step, except the last one that will remove the residual stock.

It is defined in radius and depending on the value assigned to parameter "A", this value will be interpreted, Like "I", as excess stock in X or in Z. If programmed with a 0 value, the CNC will display the corresponding error message.
- A1** It defines the main machining axis.
 - When programming "A0", the Z axis will be the main axis, "I" will be taken as X residual value and "C" as the pass along X.
 - When programming "A1", the X axis will be the main axis, "I" will be taken as Z residual value and "C" as the pass along Z.

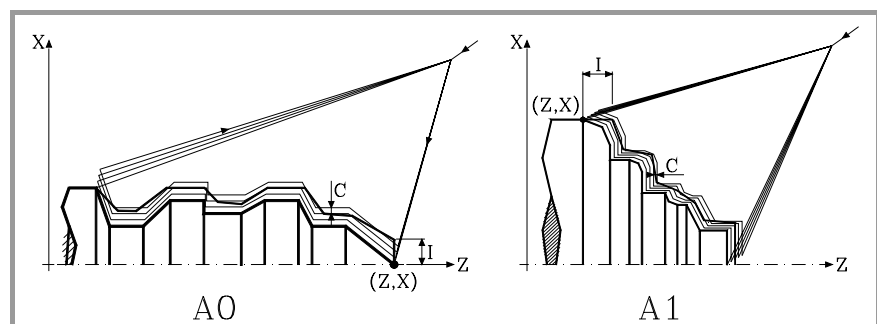

9.
CANNED CYCLES
 G66. Pattern repeat cycle canned cycle



CNC 8055
CNC 8055i

·T· MODEL
(SOFT V16.1x)

When not programming the A parameter, the "I" and "C" values depend on the tool dimensions..

- If the X length of the tool is greater than its Z length, the "I" value is assumed as excess material in X and the "C" value as a pass in X.
- If the X length of the tool is smaller than its Z length, the "I" value is assumed as excess material in Z and the "C" value as a pass in Z.

L±5.5 It defines the finishing stock in X. It is defined in radius and if not programmed, it assumes a value of "0".

M±5.5 It defines the finishing stock in Z.

If "L" or "M" is programmed with a negative value, the finishing pass is carried out in round corner mode (G05). When both parameters are programmed with a positive value, the finishing pass is carried out in square corner mode (G07).

If the parameter "M" is not programmed, the residual stock in X and Z will be the one indicated in parameter "L" and the roughing passes will be identical keeping the "C" distance between 2 consecutive passes.

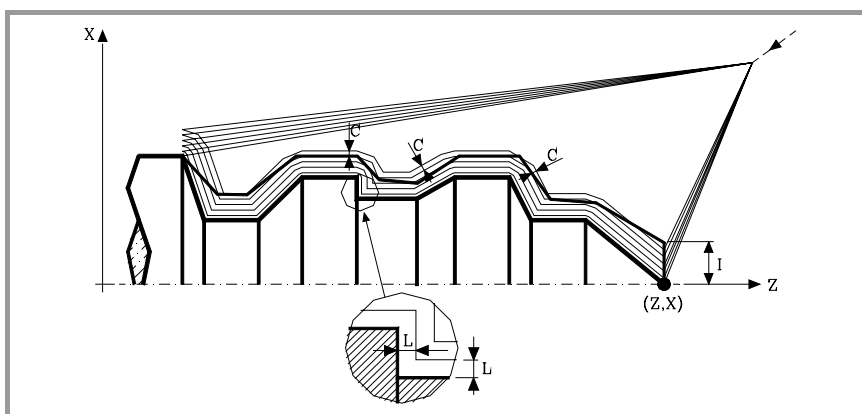

H5.5 It defines the feedrate during the finishing pass.

If not programmed or programmed with a 0 value, it does not run the finishing pass.

S4 Defines the label number of the block where the geometrical description of the profile of the part starts.

E4 Defines the label number of the block where the geometrical description of the profile of the part ends.

Q6 Defines the number of the program that contains the geometrical description of the profile.

This parameter is optional and if it is not defined, the CNC assumes that the profile is defined in the same program that is calling the cycle.

9.

CANNED CYCLES
G66. Pattern repeat cycle canned cycle

FAGOR 

CNC 8055
CNC 8055i

·T· MODEL
(SOFT V16.1X)

Considerations

The machining conditions (feedrate, spindle speed, etc.) must be programmed before calling the cycle.

The canned cycle calling point must be off the part to be machined and at a distance greater than the one defined as excess stock (I) of the most external profile of the part.

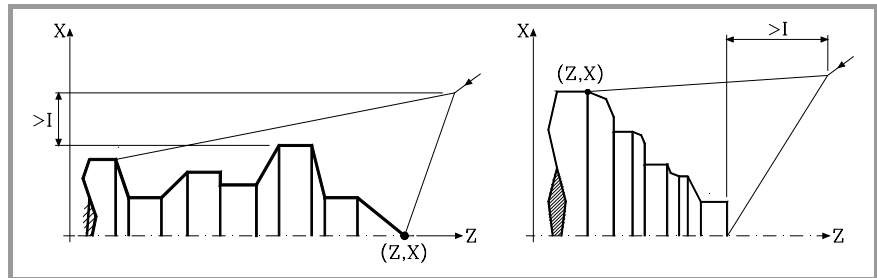

If the tool position is not correct to execute the cycle, the CNC will display the corresponding error.

Once the canned cycle has ended, the active feedrate will be the last one programmed, i.e. the one corresponding to the roughing operation (F) or to the finishing operation (H). The CNC will assume functions G00, G40 and G90.

Optimizing the machining operation

If only the desired profile is defined, the CNC assumes that the original stock is cylindrical and machines it as shown on the left.

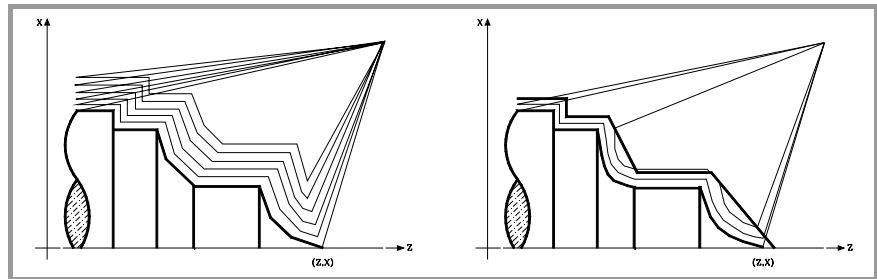

When the stock profile is known, it is recommended to define both profiles: The profile of the original stock and the desired final profile. The machining operation is much faster because only the stock delimited by both profiles is removed.

9.
CANNED CYCLES
 G66. Pattern repeat cycle canned cycle



CNC 8055
CNC 8055i

.T- MODEL
(SOFT V16.1x)

9.1.1 Basic operation

Each pass is carried out as follows:

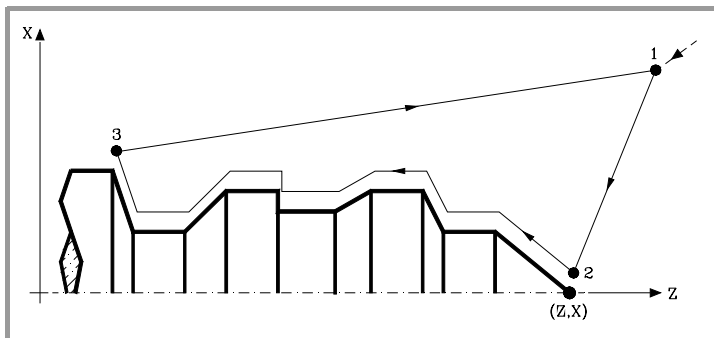

1. The approach movement "1-2" is made in rapid traverse (G00).
2. The movement "2-3" is made at programmed feedrate (F).
3. The withdrawal movement "3-1" is made in rapid traverse (G00).

If there is a chance of colliding with the part, this movement will consist of two movements in G00 ("3-4" and "4-1") as shown in the following figure.

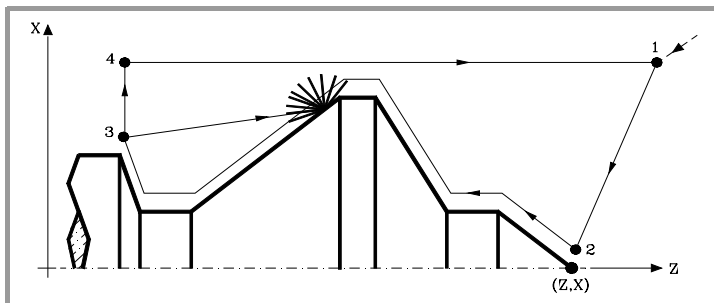

4. The canned cycle will always end at the point where the cycle was called from.

The machining passes

Once the profile to be executed is calculated, the CNC calculates all the necessary passes to remove the programmed excess stock (I).

The machining operation will be performed keeping the square corner mode (G07) or round corner mode (G05) that is active when calling the cycle.

If the parameter "M" is not programmed, the passes will be identical keeping the "C" distance between 2 consecutive passes. Also, if the last section of the profile is a curved section or an incline plane, the CNC will calculate the different passes without exceeding the programmed maximum coordinate.

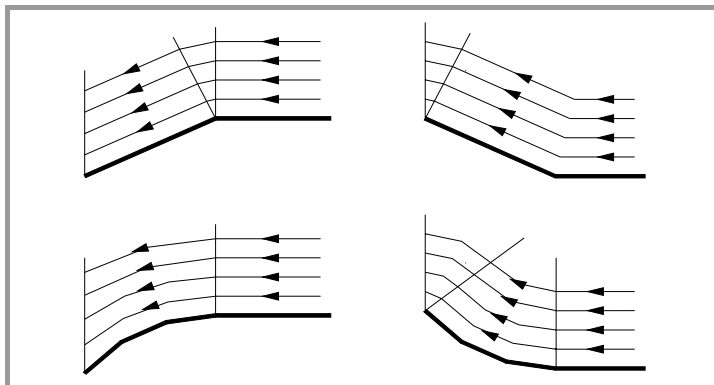

9.

CANNED CYCLES
G66. Pattern repeat cycle canned cycle



CNC 8055
CNC 8055i

·T· MODEL
(SOFT V16.1x)

The profile and the tool

After analyzing the programmed profile and depending on the tool used, it will execute that profile or the one closest to it if the one programmed cannot be executed. When the programmed profile (valleys) cannot be executed with the selected tool, a message will be displayed at the beginning of the execution of the cycle.

The operator will have the choice to stop the execution and select the right tool. If he doesn't do that, the CNC calculates a new profile in the areas that cannot be accessed by the selected tool and it machines as much as possible. The message is shown during the whole machining operation.

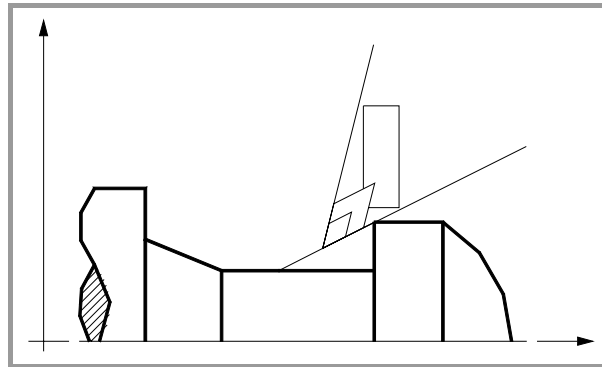

9.

CANNED CYCLES

G66. Pattern repeat cycle canned cycle



CNC 8055
CNC 8055i

.T. MODEL
(SOFT V16.1X)

9.1.2 Profile programming syntax

When defining the profile, there is no need to program the starting point because it is specified by the cycle defining parameters X and Z.

When defining 2 profiles, first define the final profile and then that of the original stock.

The first and last profile defining blocks (where the profile or profiles end) must have the block label number. These label numbers will indicate the beginning and end of the profile geometry definition.

The profile programming syntax must follow these rules:

- It may be programmed in absolute or incremental coordinates and may be made up of simple geometrical elements such as straight lines, arcs, rounded corners, chamfered corners, etc. following the syntax rules defined for this purpose.
- G00 indicates the end of the definition of the final profile and that in this block contains the beginning of the definition of the profile of the original stock.
Program G01, G02 or G03 in the next block, because G00 is modal, thus preventing the CNC from issuing the corresponding error message.
- The profile description must not contain mirror images, scaling factor changes, pattern rotation or zero offsets.
- It must not contain high level blocks such as jumps, calls to subroutines or parametric programming.
- It must not contain other canned cycles.

The following functions may be used to define the profile:

G01	Linear interpolation.
G02	Clockwise circular interpolation.
G03	Counter-clockwise circular interpolation.
G06	Circle center in absolute coordinates.
G08	Arc tangent to previous path.
G09	Arc defined by three points.
G36	Corner rounding, radius blend.
G39	Chamfer.
G53	Programming with respect to machine zero.
G70	Programming in inches.
G71	Programming in millimeters.
G90	Absolute programming.
G91	Incremental programming.
G93	Polar origin preset.

The following functions may be programmed, although the cycle will ignore them.

G05	Round corner.
G07	Square corner.
G50	Controlled round corner.
F S T D or M	functions.

9.

CANNED CYCLES

G66. Pattern repeat cycle canned cycle

FAGOR 

**CNC 8055
CNC 8055i**

·T· MODEL
(SOFT V16.1X)

9.2 G68. X axis roughing canned cycle

This cycle machines the programmed profile maintaining the indicated step between consecutive machining passes. Triangular, round and square tools may be used in this cycle.

The basic structure of the block is as follows:

G68 X Z C D L M K F H S E Q

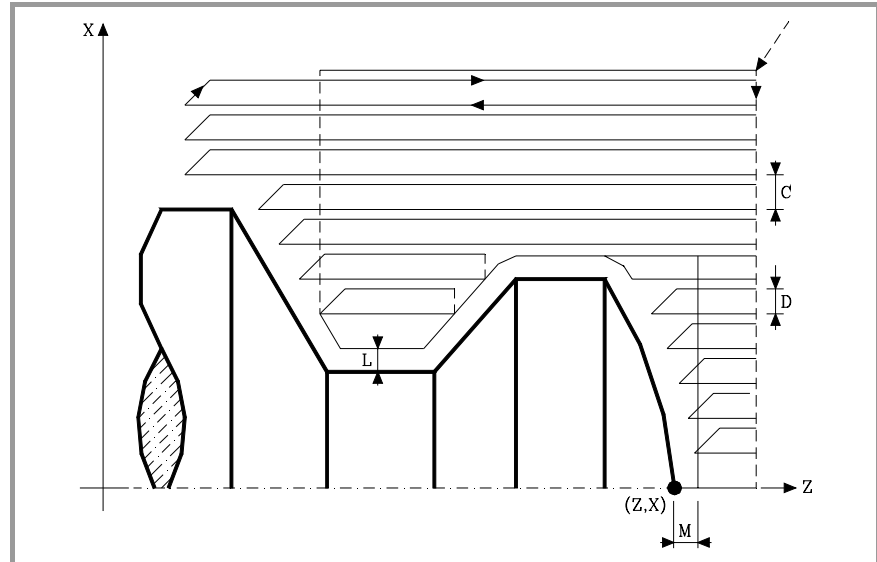

- X±5.5** It sets the X coordinate of the profile's starting point. It must be programmed in absolute coordinates and in the active units, radius or diameter.
- Z±5.5** It sets the Z coordinate of the profile's starting point. It must be programmed in absolute coordinates.
- C5.5** It sets the machining pass and is programmed with a positive value given in radius. If programmed with a 0 value, the CNC will display the corresponding error message.

All the machining passes will be run with this step, except the last one that will remove the residual stock.
- D 5.5** It sets the safety distance the tool withdraws after each pass.

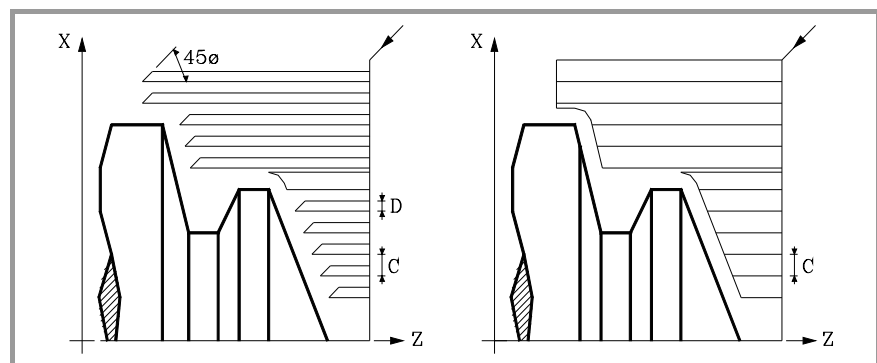

When programming D with a value other than 0, the cutter withdraws at 45° until reaching the safety distance (left figure).

When programming D with a 0 value, the exit path is the same as the entry path. This may be useful to groove complex profiles, to use these cycle on cylindrical grinders, etc.

If the parameter "D" is not programmed, the tool withdraws following the profile up to the previous pass, "C" distance (right figure).

9.
CANNED CYCLES
 G68. X axis roughing canned cycle



CNC 8055
CNC 8055i

·T· MODEL
(SOFT V16.1X)

It must be borne in mind that when not programming the parameter D, the cycle execution time is greater but the finishing stock is smaller.

L±5.5 It defines the finishing stock in X. It is defined in radius and if not programmed, it assumes a value of "0".

M±5.5 It defines the finishing stock in Z.

If "L" or "M" is programmed with a negative value, the finishing pass is carried out in round corner mode (G05). When both parameters are programmed with a positive value, the finishing pass is carried out in square corner mode (G07).

If the parameter "M" is not programmed, the residual stock indicated in the parameter "L" will be constant throughout the whole profile.

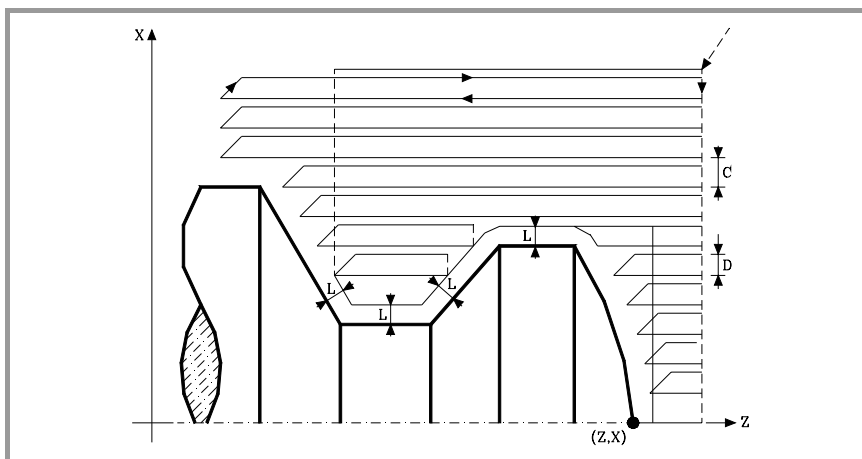

K5.5 It defines the tool feedrate to penetrate the valleys. If not programmed or programmed with a 0 value, it assumes the machining feedrate (the one programmed before calling the cycle).

F5.5 It defines the feedrate for the last roughing pass. If not programmed or programmed with a 0 value, it does not run the last roughing pass.

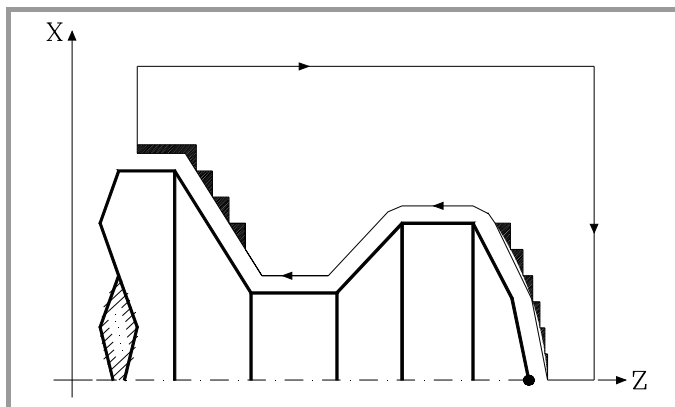

H5.5 It defines the feedrate during the finishing pass. If not programmed or programmed with a 0 value, it does not run the finishing pass.

S4 Defines the label number of the block where the geometrical description of the profile of the part starts.

E4 Defines the label number of the block where the geometrical description of the profile of the part ends.

Q6 Defines the number of the program that contains the geometrical description of the profile.

This parameter is optional and if it is not defined, the CNC assumes that the profile is defined in the same program that is calling the cycle.

9.

CANNED CYCLES
G68. X axis roughing canned cycle



CNC 8055
CNC 8055i

·T· MODEL
(SOFT V16.1X)

Considerations

The machining conditions (feedrate, spindle speed, etc.) must be programmed before calling the cycle.

The canned cycle calling point must be off the part to be machined and at a distance greater than the one defined as excess stock (L, M) along the X and Z axes.

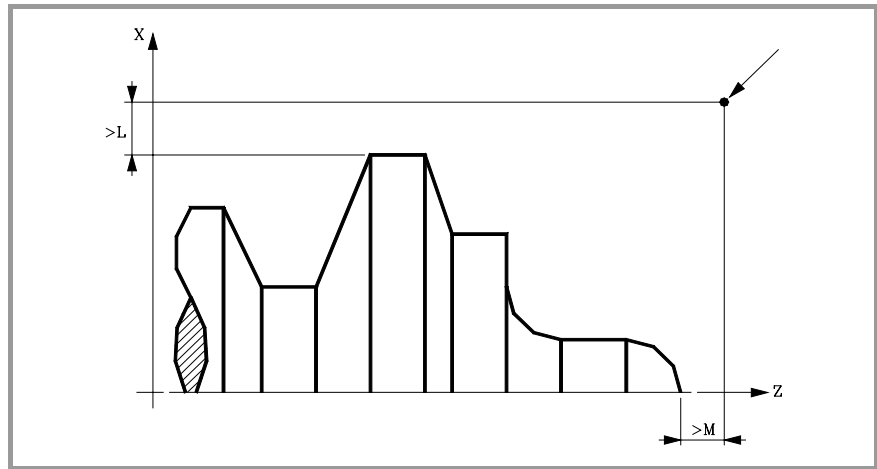

If the tool position is not correct to execute the cycle, the CNC will display the corresponding error.

Once the canned cycle has ended, the active feedrate will be the last one programmed, i.e. the one corresponding to the roughing operation (F) or to the finishing operation (H). The CNC will assume functions G00, G40 and G90.

Optimizing the machining operation

If only the desired profile is defined, the CNC assumes that the original stock is cylindrical and machines it as shown on the left.

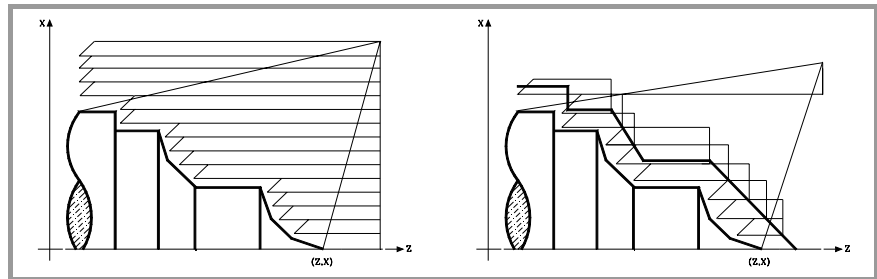

When the stock profile is known, it is recommended to define both profiles: The profile of the original stock and the desired final profile. The machining operation is much faster because only the stock delimited by both profiles is removed.

9.
CANNED CYCLES
 G68. X axis roughing canned cycle



CNC 8055
 CNC 8055i

.T- MODEL
 (SOFT V16.1x)

9.2.1 Basic operation

The machining passes

Once the necessary roughing passes have been calculated, it will machine the new resulting profile.

The machining operation will be performed keeping the square corner mode (G07) or round corner mode (G05) that is active when calling the cycle. Likewise, it maintains the same pass during the whole machining operation.

The profile and the tool

After analyzing the programmed profile and depending on the tool used, it will execute that profile or the one closest to it if the one programmed cannot be executed. When the programmed profile (valleys) cannot be executed with the selected tool, a message will be displayed at the beginning of the execution of the cycle.

The operator will have the choice to stop the execution and select the right tool. If he doesn't do that, the CNC calculates a new profile in the areas that cannot be accessed by the selected tool and it machines as much as possible. The message is shown during the whole machining operation.

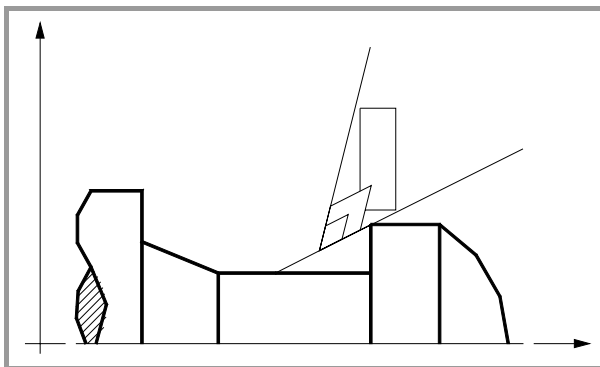

Machining of channels

If when running one of the roughing passes, the CNC detects that there is a channel, the CNC will go on executing the rest of the profile ignoring that channel. A profile may have an unlimited number of channels.

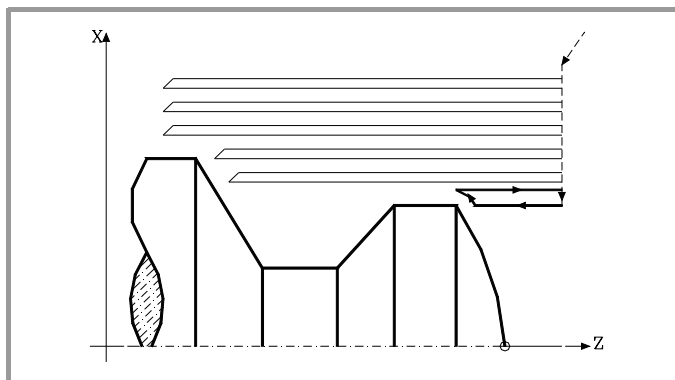

Once the CNC is done machining the excess profile, it will start executing the detected channels.

9.

CANNED CYCLES
G68. X axis roughing canned cycle

FAGOR 

CNC 8055
CNC 8055i

·T· MODEL
(SOFT V16.1x)

9.

CANNED CYCLES

G68. X axis roughing canned cycle

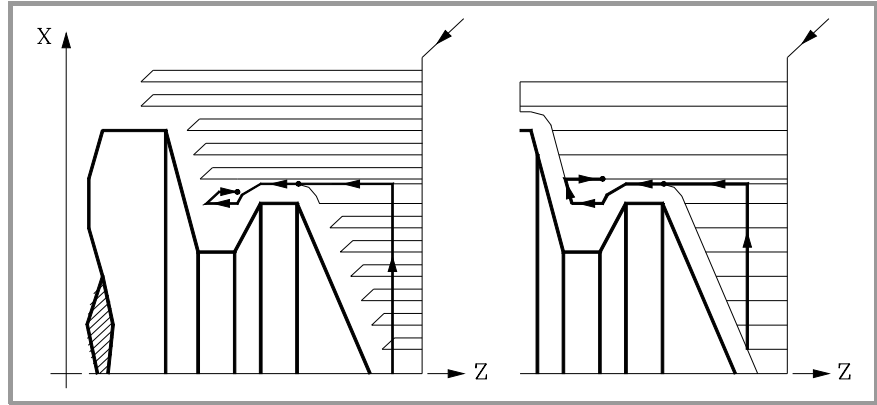

To do this, it will return in G00 to the point where the machining of the profile was interrupted.

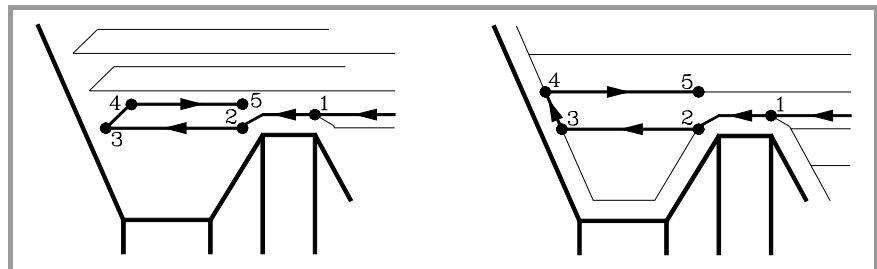

1. From this point on, it will follow the programmed contour in G01 maintaining the finishing stock until reaching the selected pass depth "C". Section 1-2.
2. In the new roughing pass, the movement "2-3" is made in G01 at the programmed feedrate (F).
3. If "D" has been programmed, the 3-4 move is done in rapid (G00); but if "D" has not been programmed, the 3-4 move is done following the profile in G01 at the programmed feedrate (F).
4. The withdrawal movement "4-5" is made in rapid traverse (G00).

If when machining a channel, other channels inside it are detected, the same procedure explained above will be followed.

Last roughing pass

If a final roughing pass has been programmed, the CNC will run a pass parallel to the profile maintaining an "L" stock at the set feedrate "F". This final roughing pass will eliminate the ridges that were left in the roughing stage.

Once the profile roughing operation has ended, the tool will return to the point from where the cycle was called.

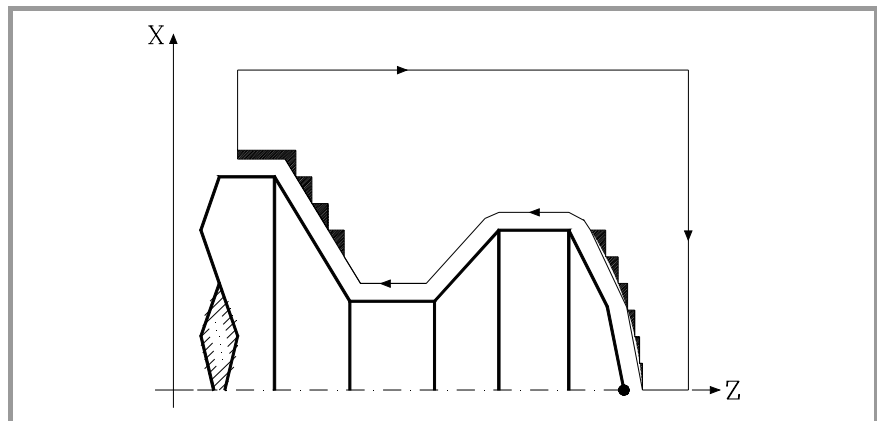

CNC 8055
CNC 8055i

.T- MODEL
(SOFT V16.1x)

Last finishing pass

If a finishing pass has been defined, it will be carried out with tool radius compensation and at the indicated feedrate "H".

This profile will coincide or not with the programmed profile depending on whether there are areas not accessible to the selected tool.

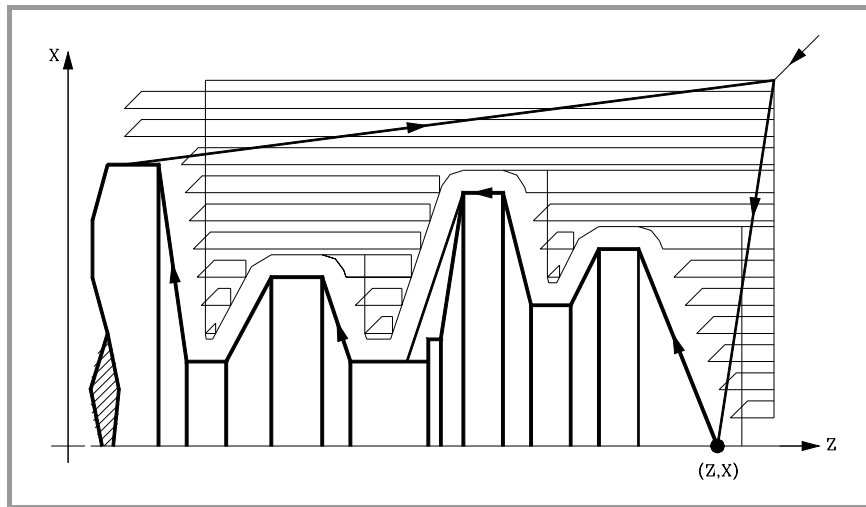

Once the finishing pass has ended, the tool will return to the point from where the cycle was called.

9.

CANNED CYCLES
G68. X axis roughing canned cycle



CNC 8055
CNC 8055i

·T· MODEL
(SOFT V16.1X)

9.2.2 Profile programming syntax

When defining the profile, there is no need to program the starting point because it is specified by the cycle defining parameters X and Z.

When defining 2 profiles, first define the final profile and then that of the original stock.

The first and last profile defining blocks (where the profile or profiles end) must have the block label number. These label numbers will indicate the beginning and end of the profile geometry definition.

The profile programming syntax must follow these rules:

- It may be programmed in absolute or incremental coordinates and may be made up of simple geometrical elements such as straight lines, arcs, rounded corners, chamfered corners, etc. following the syntax rules defined for this purpose.
- G00 indicates the end of the definition of the final profile and that in this block contains the beginning of the definition of the profile of the original stock.
Program G01, G02 or G03 in the next block, because G00 is modal, thus preventing the CNC from issuing the corresponding error message.
- The profile description must not contain mirror images, scaling factor changes, pattern rotation or zero offsets.
- It must not contain high level blocks such as jumps, calls to subroutines or parametric programming.
- It must not contain other canned cycles.

The following functions may be used to define the profile:

G01	Linear interpolation.
G02	Clockwise circular interpolation.
G03	Counter-clockwise circular interpolation.
G06	Circle center in absolute coordinates.
G08	Arc tangent to previous path.
G09	Arc defined by three points.
G36	Corner rounding, radius blend.
G39	Chamfer.
G53	Programming with respect to machine zero.
G70	Programming in inches.
G71	Programming in millimeters.
G90	Absolute programming.
G91	Incremental programming.
G93	Polar origin preset.

The following functions may be programmed, although the cycle will ignore them.

G05	Round corner.
G07	Square corner.
G50	Controlled round corner.

F S T D or M functions.

9.

CANNED CYCLES
G68. X axis roughing canned cycle



CNC 8055
CNC 8055i

.T- MODEL
(SOFT V16.1x)

9.3 G69. Z axis roughing canned cycle

This cycle machines the programmed profile maintaining the indicated step between consecutive machining passes. Triangular, round and square tools may be used in this cycle.

The basic structure of the block is as follows:

```
G69X Z C D L M K F H S E Q
```

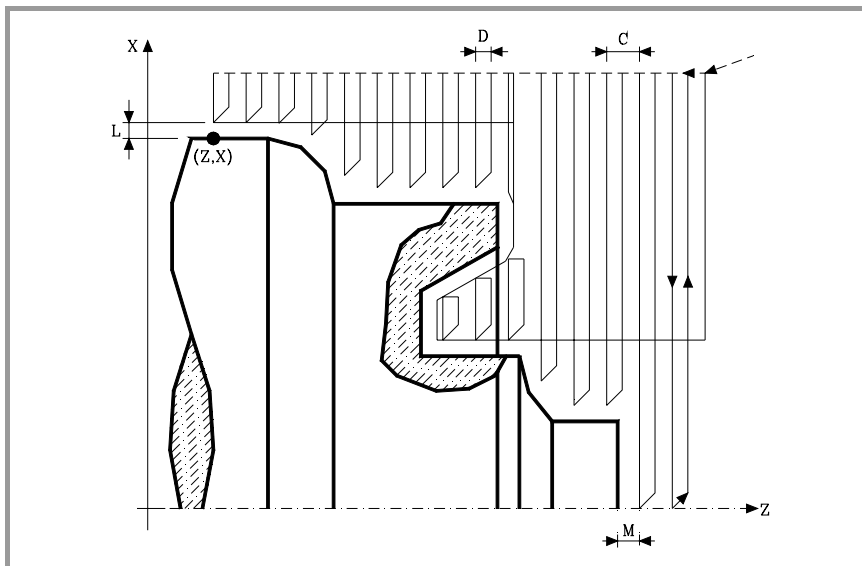

9.

CANNED CYCLES
G69. Z axis roughing canned cycle

X±5.5 It sets the X coordinate of the profile's starting point. It must be programmed in absolute coordinates and in the active units, radius or diameter.

Z±5.5 It sets the Z coordinate of the profile's starting point. It must be programmed in absolute coordinates.

C5.5 It defines the machining pass. If programmed with a 0 value, the CNC will display the corresponding error message.

All the machining passes will be run with this step, except the last one that will remove the residual stock.

D 5.5 It sets the safety distance the tool withdraws after each pass.

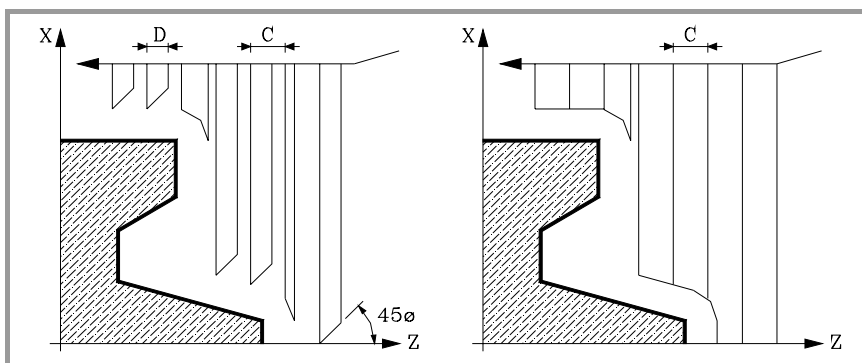

When programming D with a value other than 0, the cutter withdraws at 45° until reaching the safety distance (left figure).

When programming D with a 0 value, the exit path is the same as the entry path. This may be useful to groove complex profiles, to use these cycle on cylindrical grinders, etc.

If the parameter "D" is not programmed, the tool withdraws following the profile up to the previous pass, "C" distance (right figure).



CNC 8055
CNC 8055i

·T· MODEL
(SOFT V16.1X)

9.

CANNED CYCLES

G69. Z axis roughing canned cycle

It must be borne in mind that when not programming the parameter D, the cycle execution time is greater but the finishing stock is smaller.

L±5.5 It defines the finishing stock in X. It is defined in radius and if not programmed, it assumes a value of "0".

M±5.5 It defines the finishing stock in Z.

If "L" or "M" is programmed with a negative value, the finishing pass is carried out in round corner mode (G05). When both parameters are programmed with a positive value, the finishing pass is carried out in square corner mode (G07).

If the parameter "M" is not programmed, the residual stock indicated in the parameter "L" will be constant throughout the whole profile.

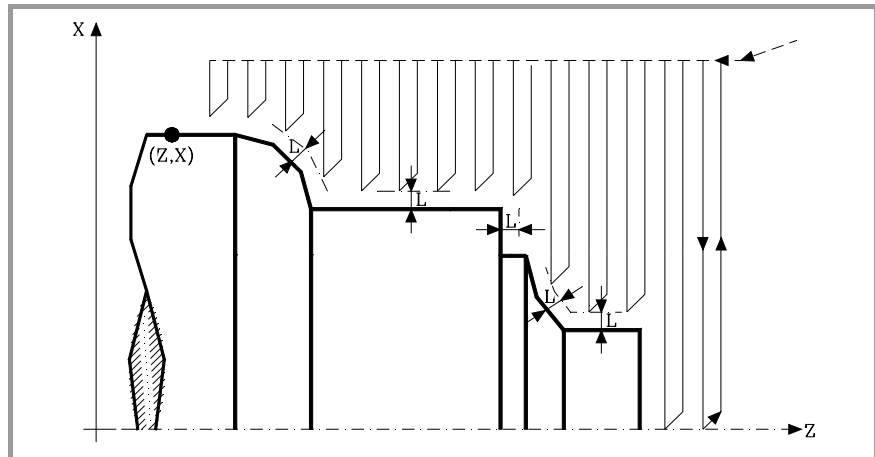

K5.5 It defines the tool feedrate to penetrate the valleys. If not programmed or programmed with a 0 value, it assumes the machining feedrate (the one programmed before calling the cycle).

F5.5 It defines the feedrate for the last roughing pass. If not programmed or programmed with a 0 value, it does not run the last roughing pass.

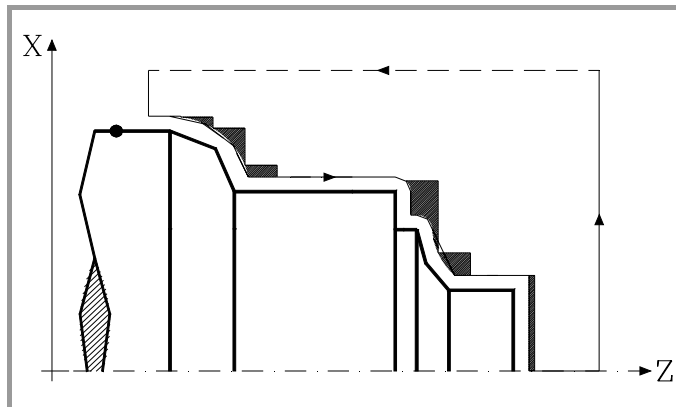

H5.5 It defines the feedrate during the finishing pass. If not programmed or programmed with a 0 value, it does not run the finishing pass.

S4 Defines the label number of the block where the geometrical description of the profile of the part starts.

E4 Defines the label number of the block where the geometrical description of the profile of the part ends.

Q6 Defines the number of the program that contains the geometrical description of the profile.

This parameter is optional and if it is not defined, the CNC assumes that the profile is defined in the same program that is calling the cycle.

Considerations

The machining conditions (feedrate, spindle speed, etc.) must be programmed before calling the cycle.

The canned cycle calling point must be off the part to be machined and at a distance greater than the one defined as excess stock (L, M) along the X and Z axes.

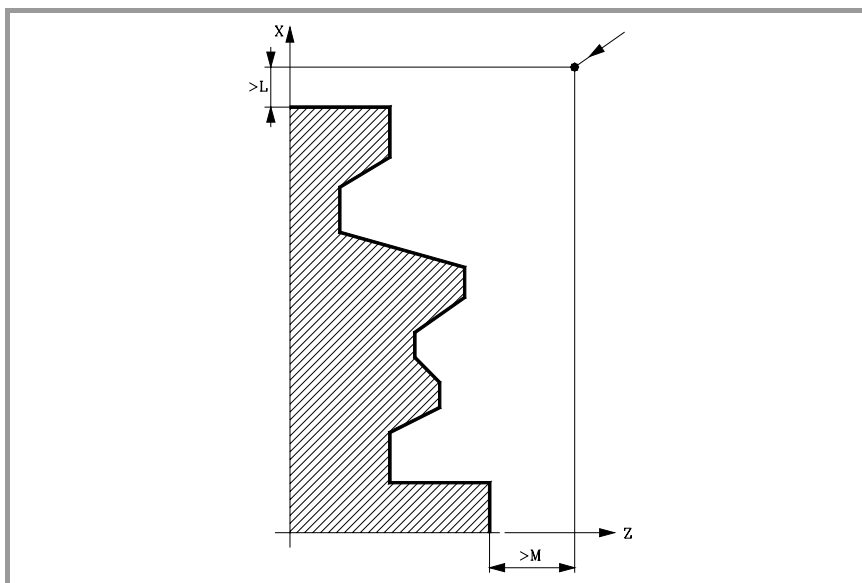

If the tool position is not correct to execute the cycle, the CNC will display the corresponding error.

Once the canned cycle has ended, the active feedrate will be the last one programmed, i.e. the one corresponding to the roughing operation (F) or to the finishing operation (H). The CNC will assume functions G00, G40 and G90.

Optimizing the machining operation

If only the desired profile is defined, the CNC assumes that the original stock is cylindrical and machines it as shown on the left.

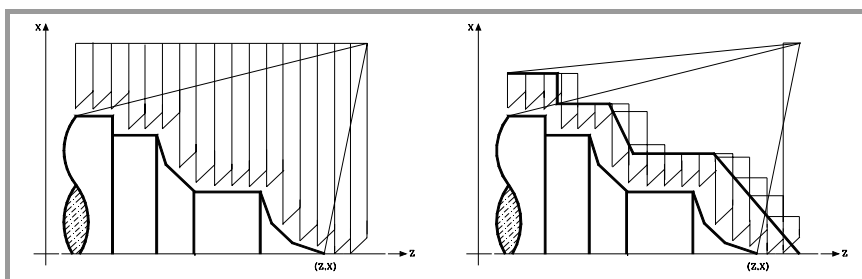

When the stock profile is known, it is recommended to define both profiles: The profile of the original stock and the desired final profile. The machining operation is much faster because only the stock delimited by both profiles is removed.

9.

CANNED CYCLES
G69. Z axis roughing canned cycle

FAGOR 

CNC 8055
CNC 8055i

·T· MODEL
(SOFT V16.1x)

9.3.1 Basic operation

The machining passes

Once the necessary roughing passes have been calculated, it will machine the new resulting profile.

The machining operation will be performed keeping the square corner mode (G07) or round corner mode (G05) that is active when calling the cycle. Likewise, it maintains the same pass during the whole machining operation.

The profile and the tool

After analyzing the programmed profile and depending on the tool used, it will execute that profile or the one closest to it if the one programmed cannot be executed. When the programmed profile (valleys) cannot be executed with the selected tool, a message will be displayed at the beginning of the execution of the cycle.

The operator will have the choice to stop the execution and select the right tool. If he doesn't do that, the CNC calculates a new profile in the areas that cannot be accessed by the selected tool and it machines as much as possible. The message is shown during the whole machining operation.

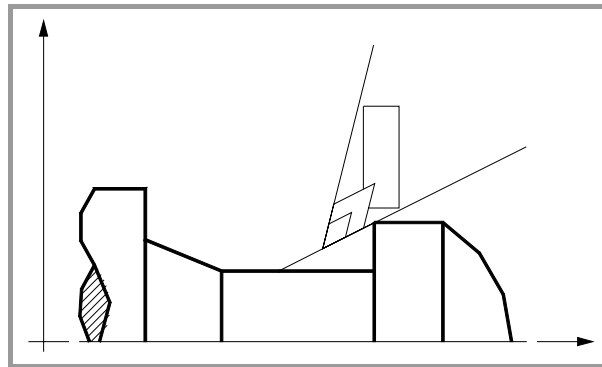

Machining of channels

If when running one of the roughing passes, the CNC detects that there is a channel, the CNC will go on executing the rest of the profile ignoring that channel. A profile may have an unlimited number of channels.

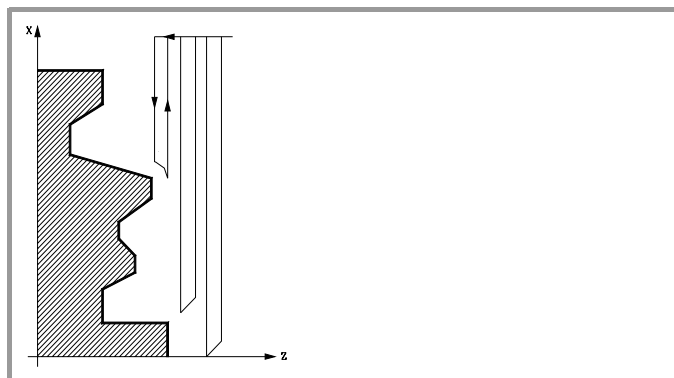

9.

CANNED CYCLES
G69. Z axis roughing canned cycle



CNC 8055
CNC 8055i

.T- MODEL
(SOFT V16.1x)

Once the CNC is done machining the excess profile, it will start executing the detected channels.

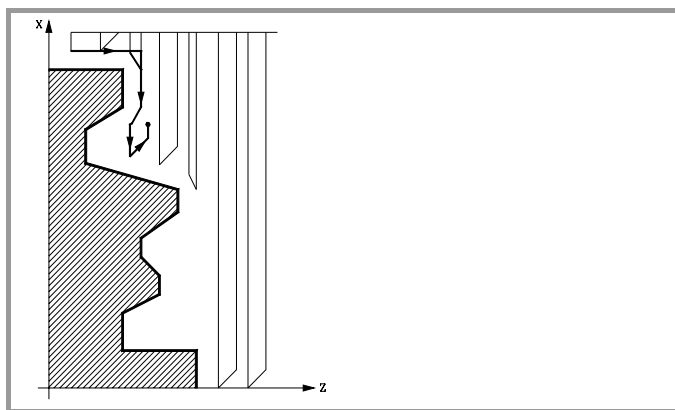

To do this, it will return in G00 to the point where the machining of the profile was interrupted.

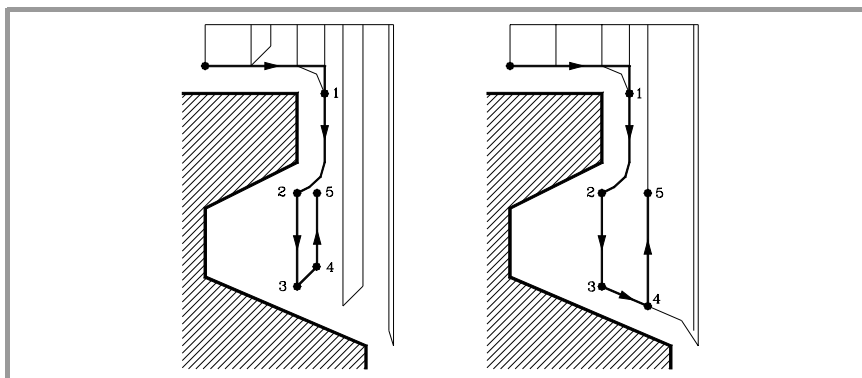

1. From this point on, it will follow the programmed contour in G01 maintaining the finishing stock until reaching the selected pass depth "C". Section 1-2.
2. In the new roughing pass, the movement "2-3" is made in G01 at the programmed feedrate (F).
3. If "D" has been programmed, the 3-4 move is done in rapid (G00); but if "D" has not been programmed, the 3-4 move is done following the profile in G01 at the programmed feedrate (F).
4. The withdrawal movement "4-5" is made in rapid traverse (G00).

If when machining a channel, other channels inside it are detected, the same procedure explained above will be followed.

9.

CANNED CYCLES

G69. Z axis roughing canned cycle



CNC 8055
CNC 8055i

·T· MODEL
(SOFT V16.1X)

Last roughing pass

If a final roughing pass has been programmed, the CNC will run a pass parallel to the profile maintaining an "L" stock at the set feedrate "F". This final roughing pass will eliminate the ridges that were left in the roughing stage.

Once the profile roughing operation has ended, the tool will return to the point from where the cycle was called.

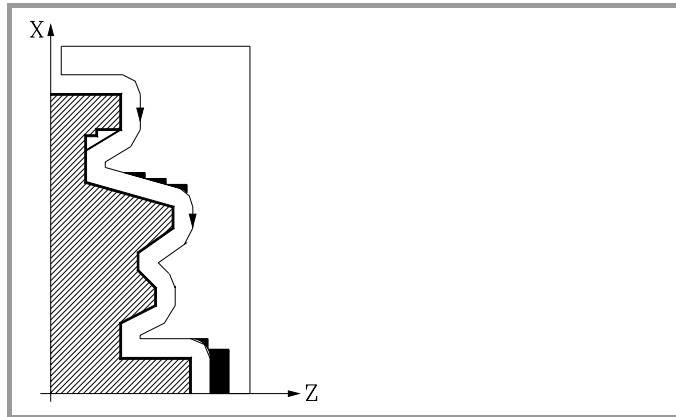

Last finishing pass

If a finishing pass has been defined, it will be carried out with tool radius compensation and at the indicated feedrate "H".

This profile will coincide or not with the programmed profile depending on whether there are areas not accessible to the selected tool.

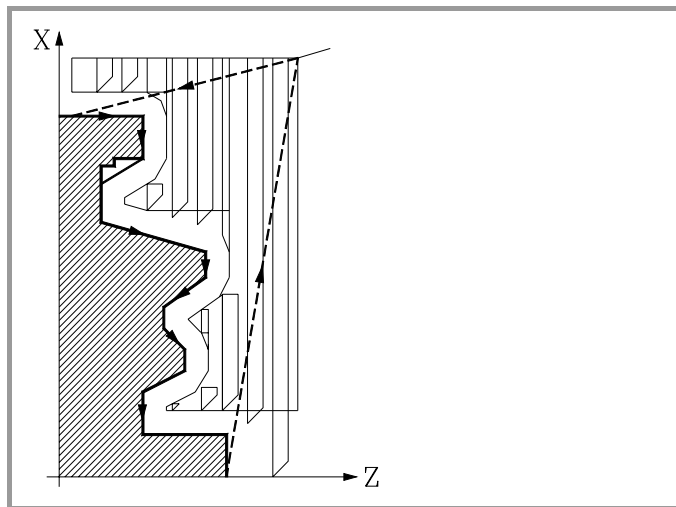

Once the finishing pass has ended, the tool will return to the point from where the cycle was called.

9.
CANNED CYCLES
 G69. Z axis roughing canned cycle



CNC 8055
 CNC 8055i

.T- MODEL
 (SOFT V16.1x)

9.3.2 Profile programming syntax

When defining the profile, there is no need to program the starting point because it is specified by the cycle defining parameters X and Z.

When defining 2 profiles, first define the final profile and then that of the original stock.

The first and last profile defining blocks (where the profile or profiles end) must have the block label number. These label numbers will indicate the beginning and end of the profile geometry definition.

The profile programming syntax must follow these rules:

- It may be programmed in absolute or incremental coordinates and may be made up of simple geometrical elements such as straight lines, arcs, rounded corners, chamfered corners, etc. following the syntax rules defined for this purpose.
- G00 indicates the end of the definition of the final profile and that in this block contains the beginning of the definition of the profile of the original stock.
Program G01, G02 or G03 in the next block, because G00 is modal, thus preventing the CNC from issuing the corresponding error message.
- The profile description must not contain mirror images, scaling factor changes, pattern rotation or zero offsets.
- It must not contain high level blocks such as jumps, calls to subroutines or parametric programming.
- It must not contain other canned cycles.

The following functions may be used to define the profile:

G01	Linear interpolation.
G02	Clockwise circular interpolation.
G03	Counter-clockwise circular interpolation.
G06	Circle center in absolute coordinates.
G08	Arc tangent to previous path.
G09	Arc defined by three points.
G36	Corner rounding, radius blend.
G39	Chamfer.
G53	Programming with respect to machine zero.
G70	Programming in inches.
G71	Programming in millimeters.
G90	Absolute programming.
G91	Incremental programming.
G93	Polar origin preset.

The following functions may be programmed, although the cycle will ignore them.

G05	Round corner.
G07	Square corner.
G50	Controlled round corner.
F S T D or M	functions.

9.

CANNED CYCLES

G69. Z axis roughing canned cycle

FAGOR
CNC 8055
CNC 8055i

 ·T· MODEL
 (SOFT V16.1X)

9.4 G81. Turning canned cycle for straight sections

This cycle turns the programmed section maintaining the indicated pass between the successive turning passes. The cycle allows to select whether or not it will run a finishing pass after completing the programmed turning operation.

The basic structure of the block is as follows:

G81 X Z Q R C D L M F H

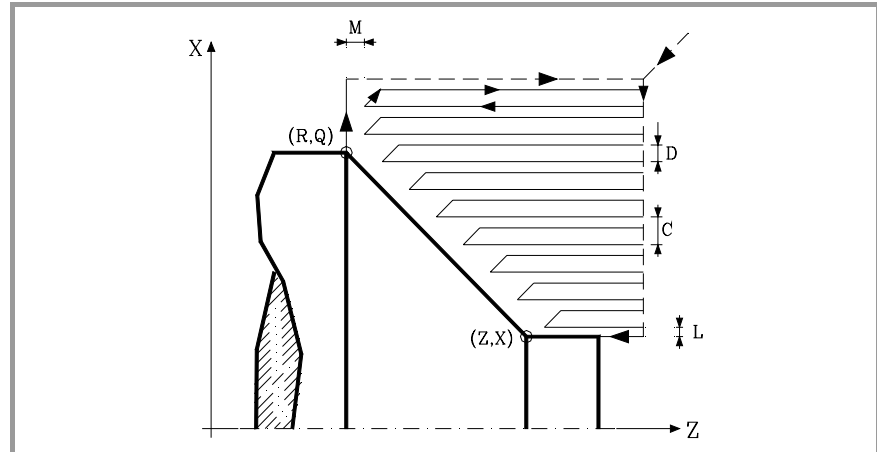

- X±5.5** It sets the X coordinate of the profile's starting point. It must be programmed in absolute coordinates and in the active units, radius or diameter.
- Z±5.5** It sets the Z coordinate of the profile's starting point. It must be programmed in absolute coordinates.
- Q±5.5** Defines the X coordinate of the final point of the profile. It must be programmed in absolute coordinates and in the active units, radius or diameter.
- R±5.5** Defines the Z coordinate of the final point of the profile.
- C5.5** Defines the turning pass. It is given by a positive radius value. If programmed with a 0 value, the CNC will display the corresponding error message.

The whole turning operation is carried out with the same pass which is the same or smaller than the programmed one "C".
- D 5.5** It sets the safety distance the tool withdraws after each pass.

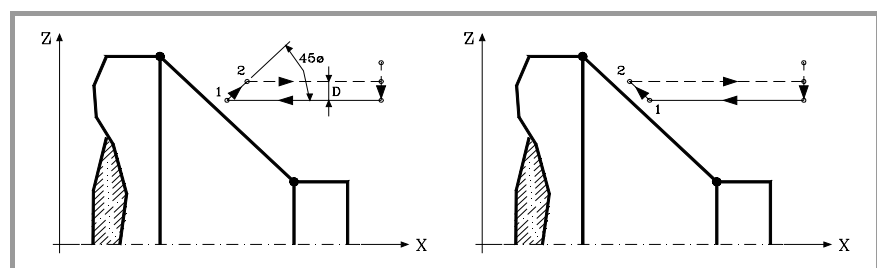

When programming D with a value other than 0, the cutter withdraws at 45° until reaching the safety distance (left figure).

When programming D with a 0 value, the exit path is the same as the entry path.

If the parameter "D" is not programmed, the tool withdraws following the profile up to the previous pass, "C" distance (right figure).

It must be borne in mind that when not programming the parameter D, the cycle execution time is greater but the finishing stock is smaller.

9.
CANNED CYCLES
 G81. Turning canned cycle for straight sections



CNC 8055
CNC 8055i

.T- MODEL
(SOFT V16.1X)

L5.5 Defines the finishing stock along X and it is given in radius.

If not programmed, a value of 0 is assumed.

M5.5 Defines the finishing stock along Z.

If not programmed, a value of 0 is assumed.

F5.5 It defines the feedrate for the last roughing pass. If not programmed or programmed with a 0 value, it does not run the last roughing pass.

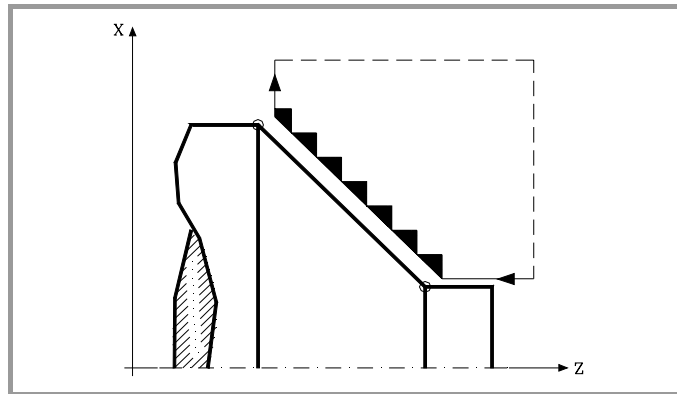

H5.5 It defines the feedrate during the finishing pass.

If not programmed or programmed with a 0 value, it does not run the finishing pass.

9.

CANNED CYCLES
G81. Turning canned cycle for straight sections



**CNC 8055
CNC 8055i**

·T· MODEL
(SOFT V16.1X)

9.4.1 Basic operation

The canned cycle will analyze the programmed profile performing, if necessary, a horizontal turning operation until the defined profile is reached. The whole turning operation is carried out with the same pass which is the same or smaller than the programmed one "C".

Each turning pass is carried out as follows:

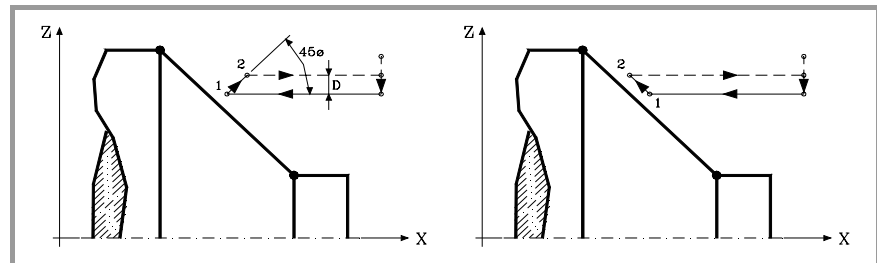

- "1-2" move in rapid (G00).
- Move "2-3" in G01 at programmed feedrate (F).
- If "D" has been programmed, the 3-4 move is done in rapid (G00); but if "D" has not been programmed, the 3-4 move is done following the profile in G01 at the programmed feedrate (F).
- The withdrawal movement "4-5" is made in rapid traverse (G00).

If a final roughing pass has been programmed, the CNC will run a pass parallel to the profile maintaining an "L" and "M" stock at the set feedrate "F". This final roughing pass will eliminate the ridges that were left in the roughing stage.

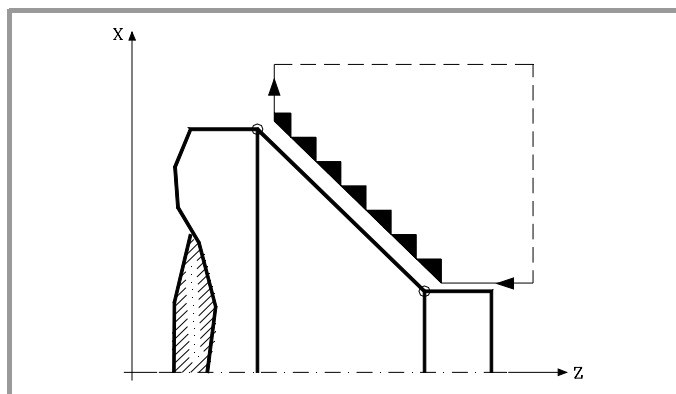

After the turning operation (with or without finishing pass) the canned cycle will always end at the cycle calling point.

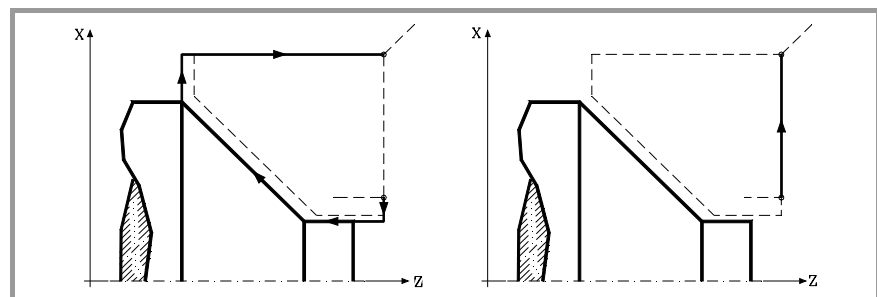

9.
CANNED CYCLES
 G81. Turning canned cycle for straight sections



CNC 8055
CNC 8055i

.T- MODEL
(SOFT V16.1x)

Considerations

The machining conditions (feedrate, spindle speed, etc.) as well as the tool radius compensation (G41, G42) must be programmed before calling the cycle.

Once the canned cycle has ended, the program will continue with the same feedrate F and G functions active previous to calling the cycle.

The distance between the starting point and final point (R,Q) along the X axis must be equal to or greater than L. The distance between the starting point and the initial point (X, Z) along the Z axis must be equal to or greater than M.

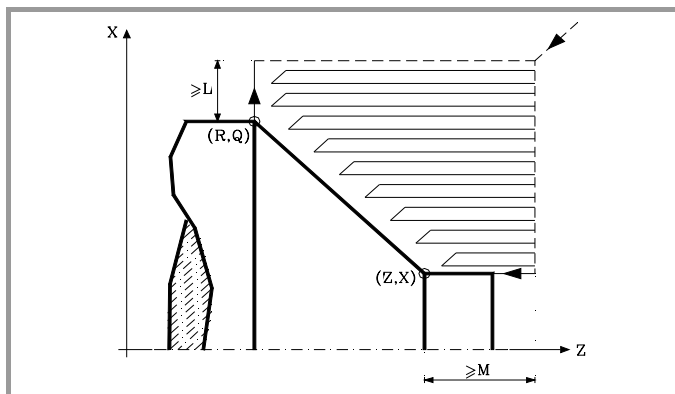

If the tool position is not correct to execute the cycle, the CNC will display the corresponding error.

9.

CANNED CYCLES
G81. Turning canned cycle for straight sections



CNC 8055
CNC 8055i

·T· MODEL
(SOFT V16.1x)

9.5 G82. Facing canned cycle for straight sections

This cycle faces the programmed section maintaining the indicated pass between the successive facing passes. The cycle allows to select whether or not it will run a finishing pass after completing the programmed facing operation.

The basic structure of the block is as follows:

G82 X Z Q R C D L M F H

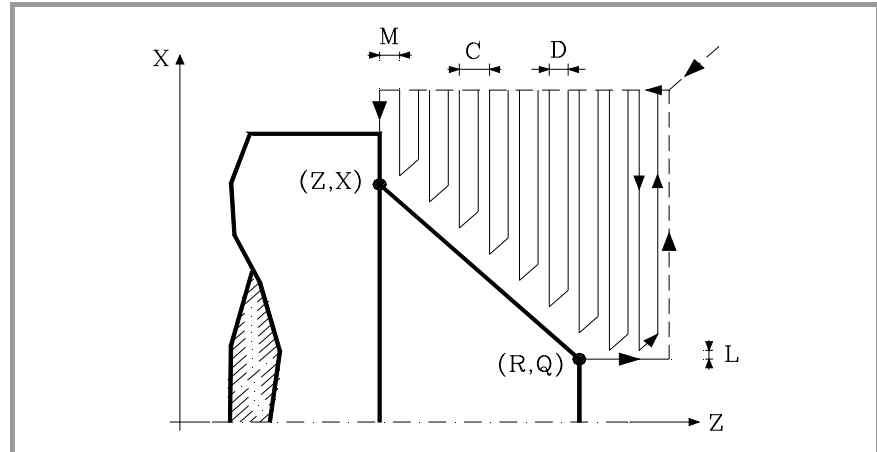

- X±5.5** It sets the X coordinate of the profile's starting point. It must be programmed in absolute coordinates and in the active units, radius or diameter.
- Z±5.5** It sets the Z coordinate of the profile's starting point. It must be programmed in absolute coordinates.
- Q±5.5** Defines the X coordinate of the final point of the profile. It must be programmed in absolute coordinates and in the active units, radius or diameter.
- R±5.5** Defines the Z coordinate of the final point of the profile.
- C5.5** Defines the facing pass.
The whole facing operation is carried out with the same pass, this being equal to or smaller than the programmed one (C).
If programmed with a 0 value, the CNC will display the corresponding error message.
- D 5.5** It sets the safety distance the tool withdraws after each pass.

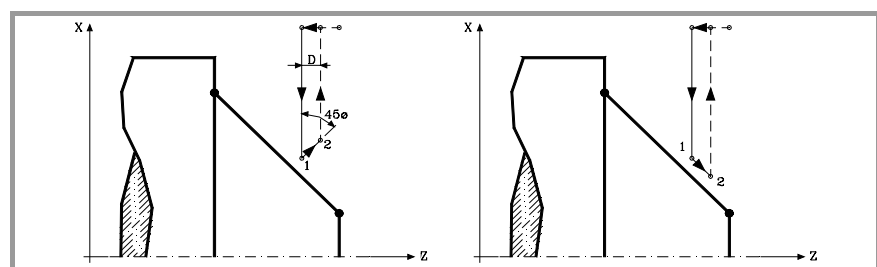

When programming D with a value other than 0, the cutter withdraws at 45° until reaching the safety distance (left figure).

When programming D with a 0 value, the exit path is the same as the entry path.

If the parameter "D" is not programmed, the tool withdraws following the profile up to the previous pass, "C" distance (right figure).

It must be borne in mind that when not programming the parameter D, the cycle execution time is greater but the finishing stock is smaller.

9.
CANNED CYCLES
 G82. Facing canned cycle for straight sections



CNC 8055
CNC 8055i

.T- MODEL
(SOFT V16.1X)

- L5.5** Defines the finishing stock along X and it is given in radius.
If not programmed, a value of 0 is assumed.
- M5.5** Defines the finishing stock along Z.
If not programmed, a value of 0 is assumed.
- F5.5** It defines the feedrate for the last roughing pass. If not programmed or programmed with a 0 value, it does not run the last roughing pass.

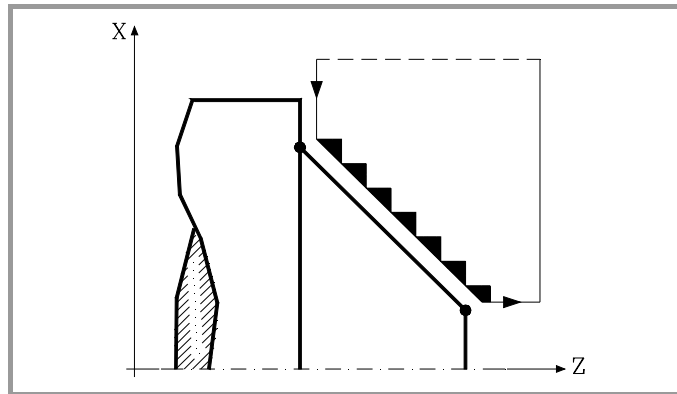

- H5.5** It defines the feedrate during the finishing pass.
If not programmed or programmed with a 0 value, it does not run the finishing pass.

9.

CANNED CYCLES
G82. Facing canned cycle for straight sections



**CNC 8055
CNC 8055i**

·T· MODEL
(SOFT V16.1X)

9.5.1 Basic operation

The canned cycle will analyze the programmed profile performing, if necessary, a facing operation until the defined profile is reached. The whole facing operation is carried out with the same pass, this being equal to or smaller than the programmed one (C).

Each facing pass is carried out in the following manner:

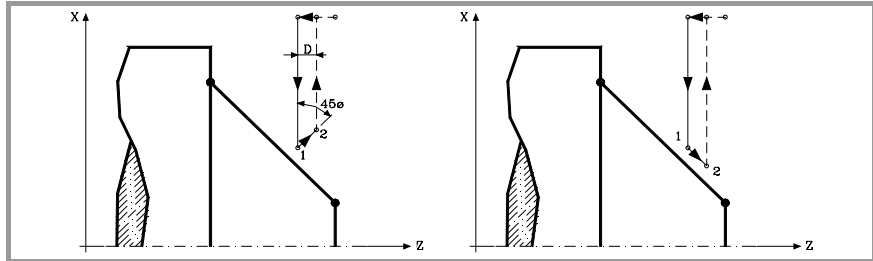

- "1-2" move in rapid (G00).
- Move "2-3" in G01 at programmed feedrate (F).
- If "D" has been programmed, the 3-4 move is done in rapid (G00); but if "D" has not been programmed, the 3-4 move is done following the profile in G01 at the programmed feedrate (F).
- The withdrawal movement "4-5" is made in rapid traverse (G00).

If a final roughing pass has been programmed, the CNC will run a pass parallel to the profile maintaining an "L" and "M" stock at the set feedrate "F". This final roughing pass will eliminate the ridges that were left in the roughing stage.

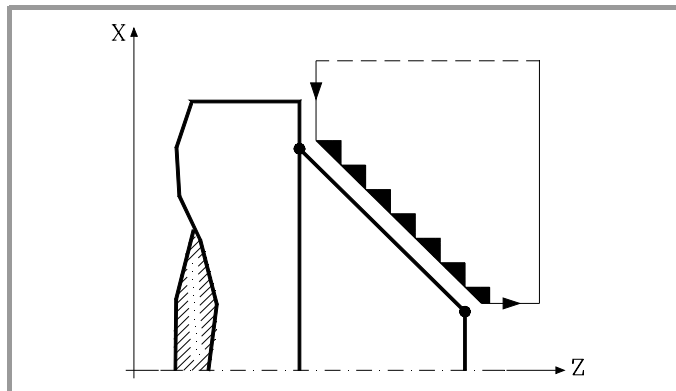

After the facing operation (with or without finishing pass) the canned cycle will always end at the cycle calling point.

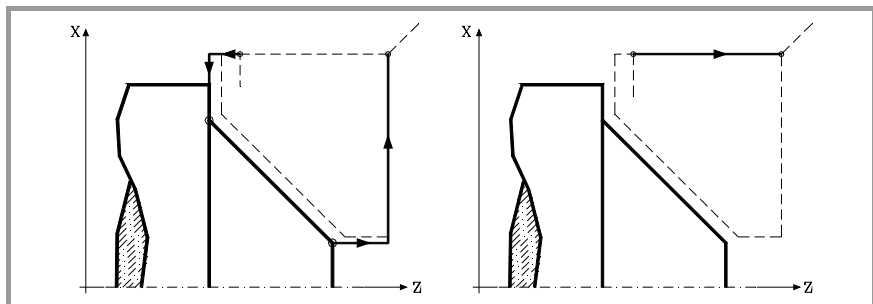

9.

CANNED CYCLES
G82. Facing canned cycle for straight sections

FAGOR 

CNC 8055
CNC 8055i

.T. MODEL
(SOFT V16.1x)

Considerations

The machining conditions (feedrate, spindle speed, etc.) as well as the tool radius compensation (G41, G42) must be programmed before calling the cycle.

Once the canned cycle has ended, the program will continue with the same feedrate F and G functions active previous to calling the cycle.

The distance between the starting point and the initial point (X, Z) along the X axis must be equal to or greater than L. The distance between the starting point and final point (R,Q) along the Z axis must be equal to or greater than M.

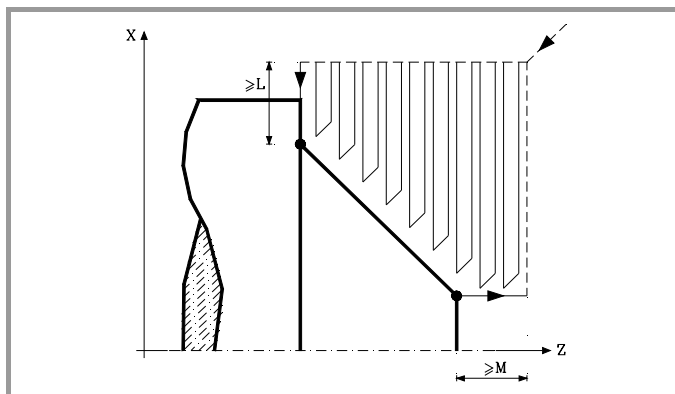

If the tool position is not correct to execute the cycle, the CNC will display the corresponding error.

9.

CANNED CYCLES
G82. Facing canned cycle for straight sections



CNC 8055
CNC 8055i

·T· MODEL
(SOFT V16.1X)

9.6 G83. Axial drilling and tapping canned cycle

This cycle may be used to carry out axial drilling or axial tapping. Whether one operation or the other will be performed depends on the format being used. For tapping, set parameter "B=0", and for axial drilling, set "B>0".

The basic block structure for each operation is:

Axial drilling G83 X Z I B D K H C L R

Axial tapping G83 X Z I B0 D K R

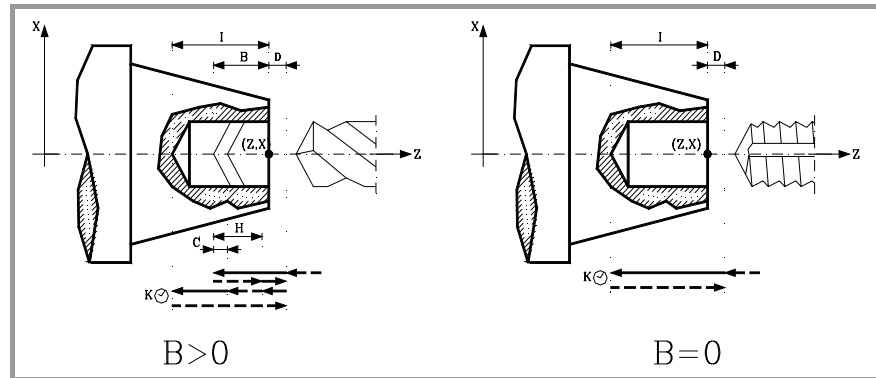

- X±5.5** Defines the X coordinate where the cycle is to be run. It must be programmed in absolute coordinates and in the active units, radius or diameter.
- Z±5.5** Defines the Z coordinate where the cycle will be run. It must be programmed in absolute coordinates.
- I±5.5** Defines the total depth. It is referred to the drilling point (X, Z); thus, it will have a positive value when drilling in the negative Z direction and vice versa.
If programmed with a 0 value, the CNC will display the corresponding error message.
- B5.5** Defines the type of operation to be run.
 - If B=0, the CNC will carry out an axial tapping.
 - If B>0 it will carry out an axial drilling where B indicates the drilling step.
- D5.5** Defines the safety distance and it indicates at what distance the tool is positioned in the approach move. If not programmed, a value of 0 is assumed.
- K5** Defines the dwell, in hundredths of a second, at the bottom of the hole before starting the withdrawal. If not programmed, a value of 0 is assumed.
- H5.5** Defines the withdrawal distance after each drilling step (in G00). If not programmed or programmed a value of 0, it will withdraw to the approach point.
- C5.5** Defines the approach distance along Z from the previous drilling step to start the next drilling step (in G00). If not programmed, a value of 1 millimeter.
- L5.5** Optional. In the drilling cycle, it defines the minimum drilling peck. It is used with "R" values other than 1.
If not programmed, a value of 0 is assumed.

9.

CANNED CYCLES
G83. Axial drilling and tapping canned cycle



CNC 8055
CNC 8055i

.T- MODEL
(SOFT V16.1x)

R5.5

In the drilling cycle, it indicates the step that reduces the drilling peck "B". If it is not programmed or is programmed with a value of "0", it assumes a value of "1".

- With $R = 1$, all the drilling pecks will be the same (the programmed "B" value).
- If R is other than 1, the first drilling peck will be "B", the second one "R B", The third one "R (RB)" and so on. In other words, from the second peck on, the new peck will be the product of the R factor times the previous peck.

In the tapping cycle, it defines the type of tapping. "R0" means regular tapping cycle and "R1" means rigid tapping. If not programmed, it takes the value of "0", regular tapping.

In order to execute a rigid tapping, the relevant spindle (main or secondary) must be ready to operate in closed loop. In other words, that it must have a servo drive-motor system with rotary encoder.

9.

CANNED CYCLES

G83. Axial drilling and tapping canned cycle



**CNC 8055
CNC 8055i**

.T- MODEL
(SOFT V16.1X)

9.6.1 Basic operation

9.

CANNED CYCLES
G83. Axial drilling and tapping canned cycle

Drilling

1. Rapid move to the approach point located at a "D" distance from the first hole position.
2. First drilling operation. The drilling axis moves in G01 to the programmed incremental depth "D+B".
3. Drilling loop. The following steps will be repeated until the programmed depth "I" is reached.
It first withdraws in rapid (G00) a distance "H" or to the approach point. Rapid approach (G00) to a "C" distance from the next peck.
New drilling step. G1 move to the next incremental depth "B and R".
4. Dwell "K" in hundredths of a second at the bottom of the hole, if programmed.
5. Withdrawal in rapid (G00) to the approach point.

Tapping

1. Rapid movement to the approach point located at a safety distance "D" from the tap point.
2. Tapping. The drilling axis moves in G01 to the programmed incremental depth "D+B".
3. Reverse the spindle turning direction.
If "K" has been programmed, the spindle stops and after the programmed dwell has elapsed, the spindle starts turning in the other way.
4. Withdrawal in work feedrate to the approach point.

Rigid tapping

1. Tapping takes place at the center of the part (X0). Rapid movement to the approach point located at a safety distance "D" from the tap point.
2. Tapping. Tapping to the incremental depth programmed in "D+B".
It is carried out by interpolating the main spindle (that is turning) with the Z axis. Rigid tapping cannot be interrupted, nor the machining conditions be changed. It is done at 100% of the programmed "S" and "F".
3. Reverse the spindle turning direction.
If "K" has been programmed, the spindle stops and after the programmed dwell has elapsed, the spindle starts turning in the other way.
4. Withdrawal in work feedrate to the approach point.

Rigid tapping is drawn with the color used for "uncompensated tool path". When the cycle is completed, the spindle stops (M5).



CNC 8055
CNC 8055i

.T- MODEL
(SOFT V16.1x)

Considerations

The machining conditions (feedrate, spindle speed, etc.) must be programmed before calling the cycle.

When tapping (regular or rigid), the general logic output "TAPPING" (M5517) stays active during the execution of the cycle.

Once the canned cycle has ended, the program will continue with the same feedrate F and G functions active previous to calling the cycle. Only the tool radius compensation will be cancelled (G40) if it was active.

9.**CANNED CYCLES**

G83. Axial drilling and tapping canned cycle

FAGOR **CNC 8055
CNC 8055i**·T· MODEL
(SOFT V16.1X)

9.7 G84. Turning canned cycle for curved sections

This cycle turns the programmed section maintaining the indicated pass between the successive turning passes. The cycle allows to select whether or not it will run a finishing pass after completing the programmed turning operation.

The basic structure of the block is as follows:

G84 X Z Q R C D L M F H I K

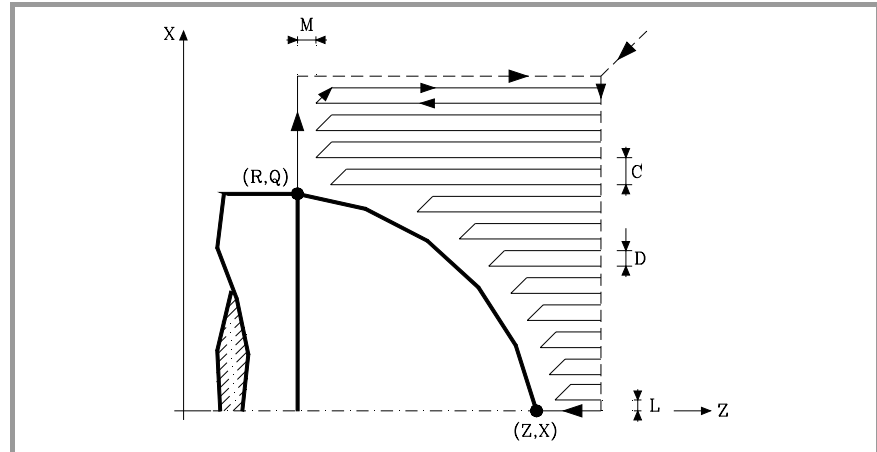

X±5.5 It sets the X coordinate of the profile's starting point. It must be programmed in absolute coordinates and in the active units, radius or diameter.

Z±5.5 It sets the Z coordinate of the profile's starting point. It must be programmed in absolute coordinates.

Q±5.5 Defines the X coordinate of the final point of the profile. It must be programmed in absolute coordinates and in the active units, radius or diameter.

R±5.5 Defines the Z coordinate of the final point of the profile.

C5.5 Defines the turning pass. It is given by a positive radius value. If programmed with a 0 value, the CNC will display the corresponding error message.

The whole turning operation is carried out with the same pass which is the same or smaller than the programmed one "C".

- D 5.5** It sets the safety distance the tool withdraws after each pass.
- When programming D with a value other than 0, the cutter withdraws at 45° until reaching the safety distance (left figure).
 - When programming D with a 0 value, the exit path is the same as the entry path.
 - If the parameter "D" is not programmed, the tool withdraws following the profile up to the previous pass, "C" distance (right figure).

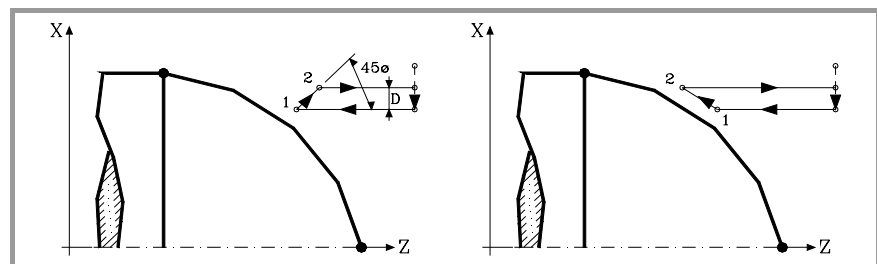

It must be borne in mind that when not programming the parameter D, the cycle execution time is greater but the finishing stock is smaller.

L5.5 Defines the finishing stock along X and it is given in radius.

If not programmed, a value of 0 is assumed.

9.

CANNED CYCLES
G84. Turning canned cycle for curved sections



CNC 8055
CNC 8055i

·T· MODEL
(SOFT V16.1X)

M5.5 Defines the finishing stock along Z.
If not programmed, a value of 0 is assumed.

F5.5 It defines the feedrate for the last roughing pass. If not programmed or programmed with a 0 value, it does not run the last roughing pass.

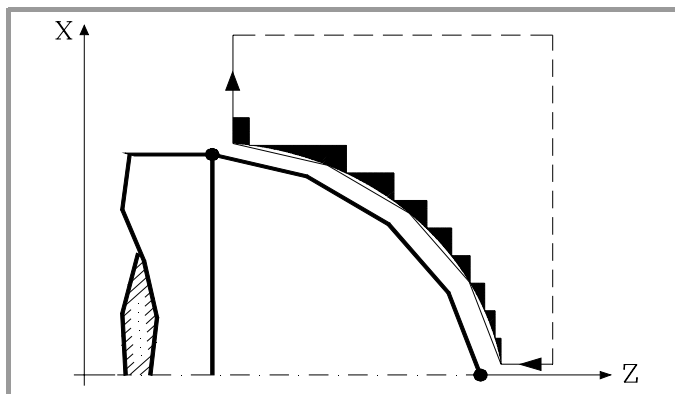

H5.5 It defines the feedrate during the finishing pass.
If not programmed or programmed with a 0 value, it does not run the finishing pass.

I±5.5 Defines the distance, in radius, from the initial point (X, Z) to the arc's center along the X axis. It is programmed in incremental values with respect to the initial point like the "I" for circular interpolations (G02, G03).

K±5.5 Defines the distance from the initial point (X, Z) to the arc's center along the Z axis. It is programmed in incremental values with respect to the initial point like the "K" for circular interpolations (G02, G03).

9.

CANNED CYCLES
G84. Turning canned cycle for curved sections



CNC 8055
CNC 8055i

·T· MODEL
(SOFT V16.1X)

9.7.1 Basic operation

The canned cycle will analyze the programmed profile performing, if necessary, a horizontal turning operation until the defined profile is reached.

The whole turning operation is carried out with the same pass which is the same or smaller than the programmed one "C". Each turning pass is carried out as follows:

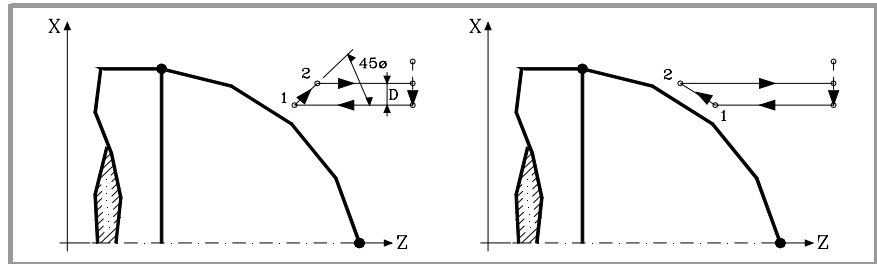

- "1-2" move in rapid (G00).
- Move "2-3" in G01 at programmed feedrate (F).
- If "D" has been programmed, the 3-4 move is done in rapid (G00); but if "D" has not been programmed, the 3-4 move is done following the profile in G01 at the programmed feedrate (F).
- The withdrawal movement "4-5" is made in rapid traverse (G00).

If a final roughing pass has been programmed, the CNC will run a pass parallel to the profile maintaining an "L" and "M" stock at the set feedrate "F". This final roughing pass will eliminate the ridges that were left in the roughing stage.

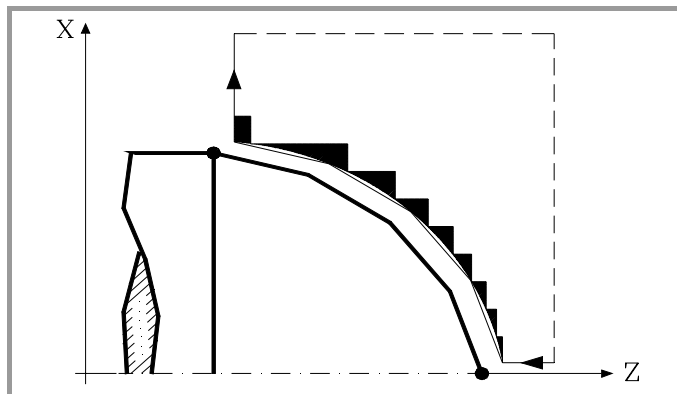

After the turning operation (with or without finishing pass) the canned cycle will always end at the cycle calling point.

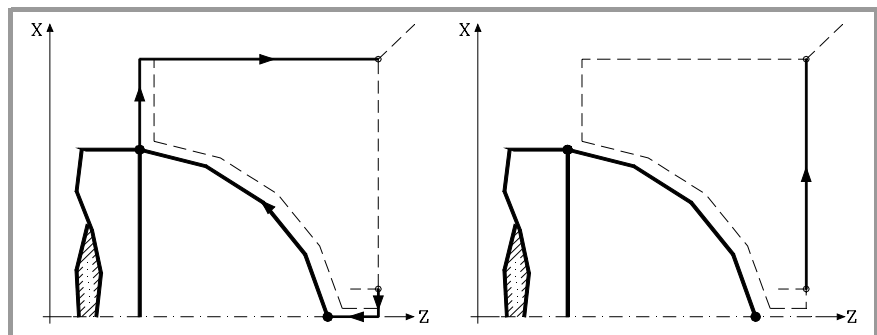

9.
CANNED CYCLES
 G84. Turning canned cycle for curved sections



CNC 8055
CNC 8055i

.T- MODEL
(SOFT V16.1x)

Considerations

The machining conditions (feedrate, spindle speed, etc.) as well as the tool radius compensation (G41, G42) must be programmed before calling the cycle.

Once the canned cycle has ended, the program will continue with the same feedrate F and G functions active previous to calling the cycle.

The distance between the starting point and final point (R,Q) along the X axis must be equal to or greater than L. The distance between the starting point and the initial point (X, Z) along the Z axis must be equal to or greater than M.

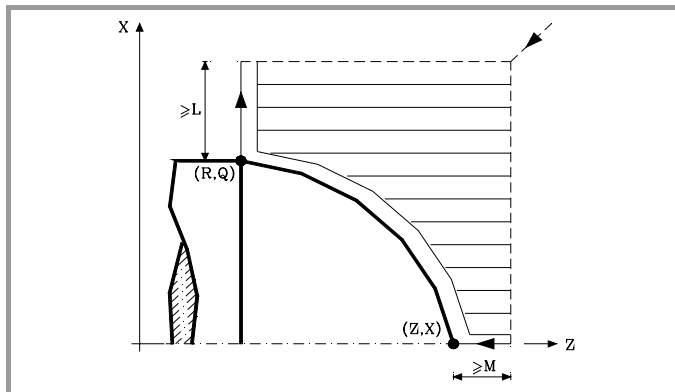

If the tool position is not correct to execute the cycle, the CNC will display the corresponding error.

9.

CANNED CYCLES
G84. Turning canned cycle for curved sections



CNC 8055
CNC 8055i

·T· MODEL
(SOFT V16.1X)

9.8 G85. Facing canned cycle for curved sections

This cycle faces the programmed section maintaining the indicated pass between the successive facing passes. The cycle allows to select whether or not it will run a finishing pass after completing the programmed facing operation.

The basic structure of the block is as follows:

G85 X Z Q R C D L M F H I K

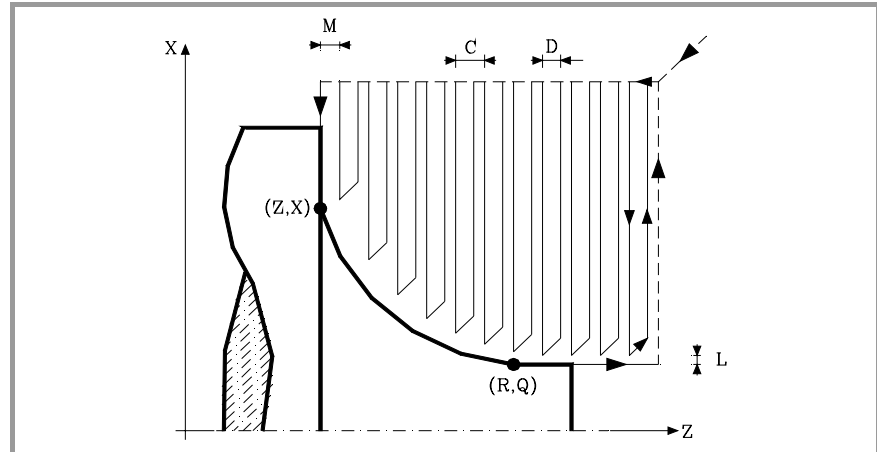

- X±5.5** It sets the X coordinate of the profile's starting point. It must be programmed in absolute coordinates and in the active units, radius or diameter.
- Z±5.5** It sets the Z coordinate of the profile's starting point. It must be programmed in absolute coordinates.
- Q±5.5** Defines the X coordinate of the final point of the profile. It must be programmed in absolute coordinates and in the active units, radius or diameter.
- R±5.5** Defines the Z coordinate of the final point of the profile.
- C5.5** Defines the facing pass. The whole facing operation is carried out with the same pass, this being equal to or smaller than the programmed one (C).
If programmed with a 0 value, the CNC will display the corresponding error message.
- D 5.5** It sets the safety distance the tool withdraws after each pass.
 - When programming D with a value other than 0, the cutter withdraws at 45° until reaching the safety distance (left figure).
 - When programming D with a 0 value, the exit path is the same as the entry path.
 - If the parameter "D" is not programmed, the tool withdraws following the profile up to the previous pass, "C" distance (right figure).

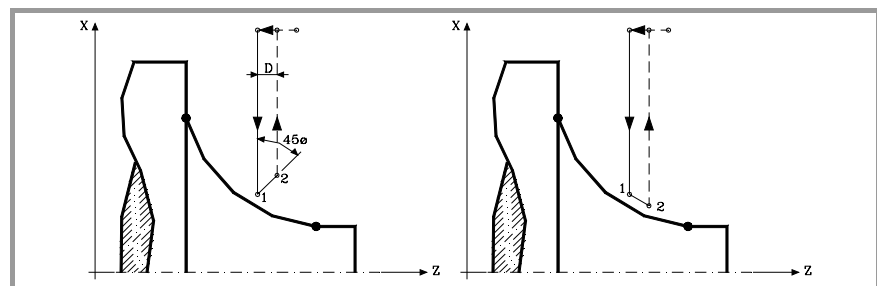

It must be borne in mind that when not programming the parameter D, the cycle execution time is greater but the finishing stock is smaller.

- L5.5** Defines the finishing stock along X and it is given in radius.
If not programmed, a value of 0 is assumed.

9.
CANNED CYCLES
G85. Facing canned cycle for curved sections



CNC 8055
CNC 8055i

.T- MODEL
(SOFT V16.1X)

M5.5 Defines the finishing stock along Z.
If not programmed, a value of 0 is assumed.

F5.5 It defines the feedrate for the last roughing pass. If not programmed or programmed with a 0 value, it does not run the last roughing pass.

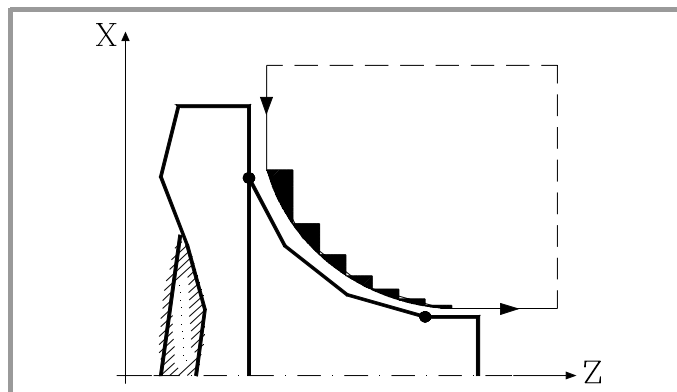

H5.5 It defines the feedrate during the finishing pass.
If not programmed or programmed with a 0 value, it does not run the finishing pass.

I±5.5 Defines the distance, in radius, from the initial point (X, Z) to the arc's center along the X axis. It is programmed in incremental values with respect to the initial point like the "I" for circular interpolations (G02, G03).

K±5.5 Defines the distance from the initial point (X, Z) to the arc's center along the Z axis. It is programmed in incremental values with respect to the initial point like the "K" for circular interpolations (G02, G03).

9.

CANNED CYCLES
G85. Facing canned cycle for curved sections



CNC 8055
CNC 8055i

·T· MODEL
(SOFT V16.1X)

9.8.1 Basic operation

The canned cycle will analyze the programmed profile performing, if necessary, a facing operation until the defined profile is reached.

The whole facing operation is carried out with the same pass, this being equal to or smaller than the programmed one (C). Each facing pass is carried out in the following manner:

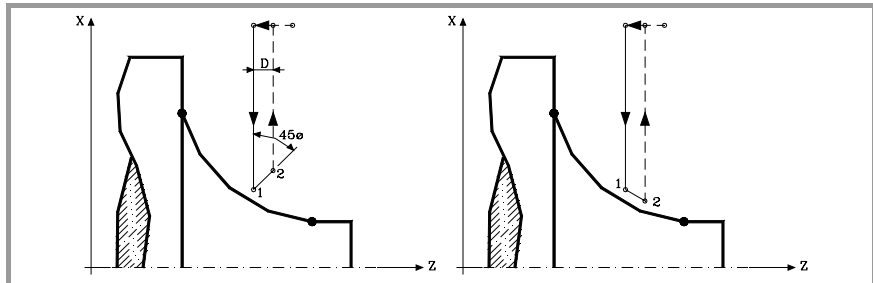

- "1-2" move in rapid (G00).
- Move "2-3" in G01 at programmed feedrate (F).
- If "D" has been programmed, the 3-4 move is done in rapid (G00); but if "D" has not been programmed, the 3-4 move is done following the profile in G01 at the programmed feedrate (F).
- The withdrawal movement "4-5" is made in rapid traverse (G00).

If a final roughing pass has been programmed, the CNC will run a pass parallel to the profile maintaining an "L" and "M" stock at the set feedrate "F". This final roughing pass will eliminate the ridges that were left in the roughing stage.

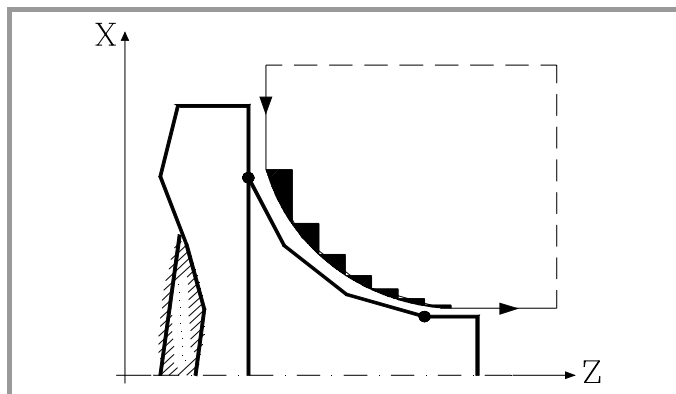

After the facing operation (with or without finishing pass) the canned cycle will always end at the cycle calling point.

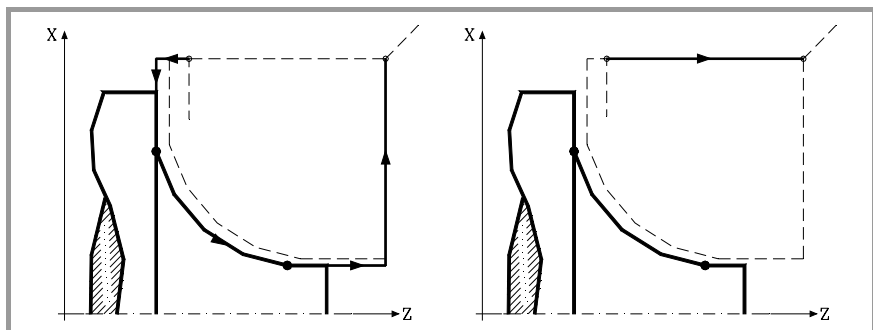

9.
CANNED CYCLES
 G85. Facing canned cycle for curved sections



CNC 8055
CNC 8055i

.T. MODEL
(SOFT V16.1x)

Considerations

The machining conditions (feedrate, spindle speed, etc.) as well as the tool radius compensation (G41, G42) must be programmed before calling the cycle.

Once the canned cycle has ended, the program will continue with the same feedrate F and G functions active previous to calling the cycle.

The distance between the starting point and the initial point (X, Z) along the X axis must be equal to or greater than L. The distance between the starting point and final point (R,Q) along the Z axis must be equal to or greater than M.

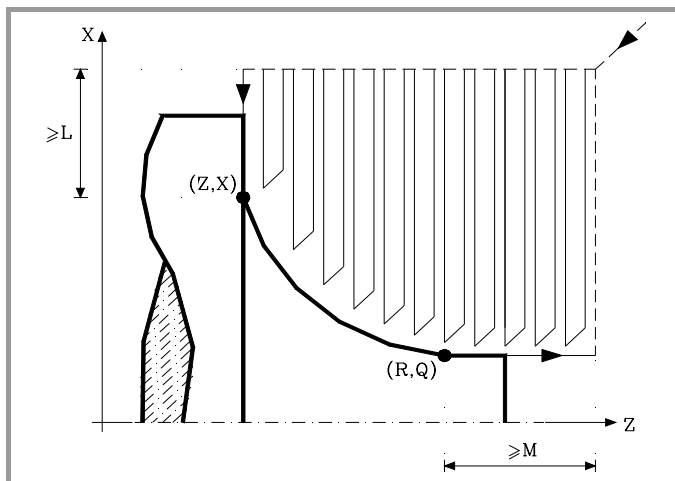

If the tool position is not correct to execute the cycle, the CNC will display the corresponding error.

9.

CANNED CYCLES
G85. Facing canned cycle for curved sections



CNC 8055
CNC 8055i

·T· MODEL
(SOFT V16.1x)

9.9 G86. Longitudinal threading canned cycle

With this cycle it is possible to cut outside, inside and tapered threads.

The right-hand and left-hand threads will be programmed by indicating the direction of the spindle rotation M03 or M04.

The basic structure of the block is as follows:

G86 X Z Q R K I B E D L C J A W V M

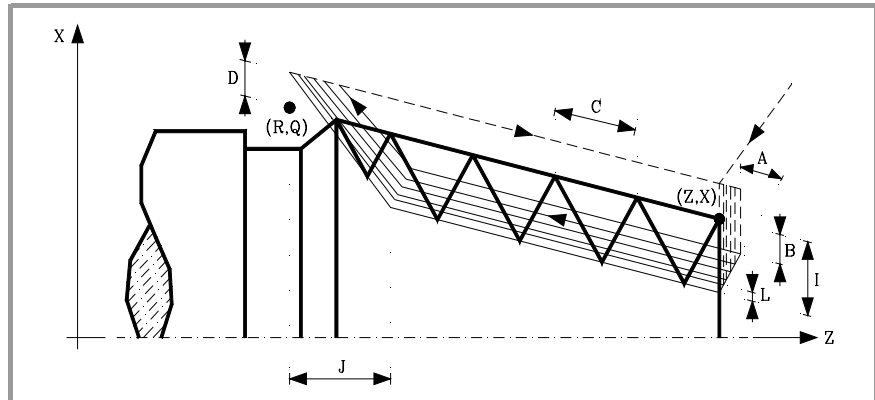

X±5.5 Defines the X coordinate of the initial point of the thread. It must be programmed in absolute coordinates and in the active units, radius or diameter.

Z±5.5 Defines the Z coordinate of the initial point of the thread. It must be programmed in absolute coordinates.

Q±5.5 Defines the X coordinate of the final point of the thread. It must be programmed in absolute coordinates and in the active units, radius or diameter.

R±5.5 Defines the Z coordinate of the final point of the thread.

K±5.5 Optional. It is used with parameter "W" for thread repair.

Defines the Z coordinate of the point where the thread is to be measured. Usually it is an intermediate point of the thread.

I±5.5 Defines the depth of the thread in radius. Its value must be positive for outside threads and negative for inside ones.

If programmed with a 0 value, the CNC will display the corresponding error message.

B±5.5 Defines the depth of the threading passes and it is given in radius.

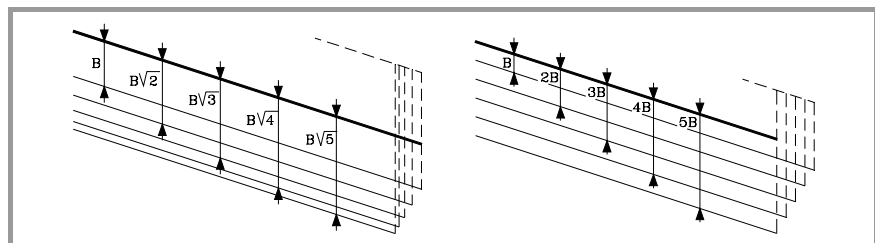

- If a positive value is programmed, the depth of each pass will depend on the number of the corresponding pass.

This way, the penetrations along the X axis are:

$$B, B\sqrt{2}, B\sqrt{3}, B\sqrt{4}, \dots, B\sqrt{n}$$

9.

CANNED CYCLES
G86. Longitudinal threading canned cycle



CNC 8055
CNC 8055i

-T- MODEL
(SOFT V16.1X)

- If a negative value is programmed, the passes will have the same depth with a value equal to the one programmed (B).

This way, the penetrations along the X axis are:

$$B, 2B, 3B, 4B, \dots nB$$

- If programmed with a 0 value, the CNC will display the corresponding error message.

Regardless of the sign assigned to "B", when the last roughing pass (before finishing) is smaller than the programmed amount, the canned cycle will run a pass equal to the residual stock.

E±5.5

It is related to parameter "B".

It indicates the minimum value to be reached the penetration pitch when parameter "B" has been programmed with a positive value.

If not programmed, a value of 0 is assumed.

D±5.5

Defines the safety distance, along X, and it indicates at what distance from the initial point must the tool be positioned in the approach move. It is programmed in radius.

The return to the initial point after each pass will be carried out maintaining this distance (D) from the programmed section.

- If the programmed value is positive, this withdrawal will be performed in round corner (G05) and if negative, in square corner (G07).
- If not programmed, a value of 0 is assumed.

L±5.5

Defines the finishing pass and it is programmed in radius.

- If a positive value is programmed, the finishing pass will be performed maintaining the same penetration angle "A" as for the other passes.

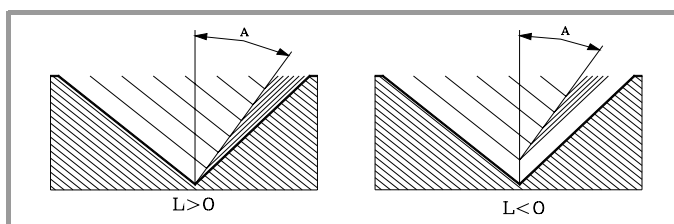

- If a negative value is programmed, the finishing pass will be carried out with radial penetration.
- If a value of 0 is programmed, the previous pass is repeated.

C5.5

Defines the thread's pitch.

- With a positive sign if the pitch is programmed along the taper.
- With a negative sign if the pitch is programmed along the associated axis.

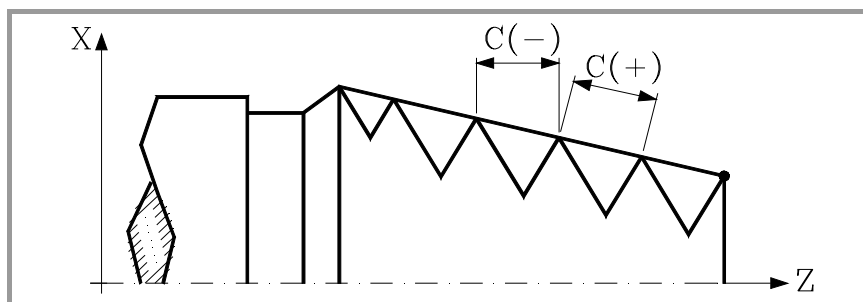

If programmed with a 0 value, the CNC will display the corresponding error message.

9.

CANNED CYCLES
G86. Longitudinal threading canned cycle



CNC 8055
CNC 8055i

·T· MODEL
(SOFT V16.1x)

J5.5

Exit from the thread. It defines at what distance from the final point (R, Q), along the Z axis, starts the withdrawal from the thread.

- If programmed with a positive value, the tool moves directly from point "J" to the safety distance X_s, Z_s .
- If programmed with a negative value, the tool moves from point "J" to the end of the thread (R, Q) and then to the safety distance X_s .
- If not programmed, a value of 0 is assumed (blind thread).

The third set of gains and accelerations for the axes and the spindle may be used to improve the adjustment and the machining of the exit from blind threads. If the thread exit is a short distance, any acceleration set may be used or even remove the acceleration without getting the error "insufficient acceleration while threading".

We recommend to use low or no acceleration.

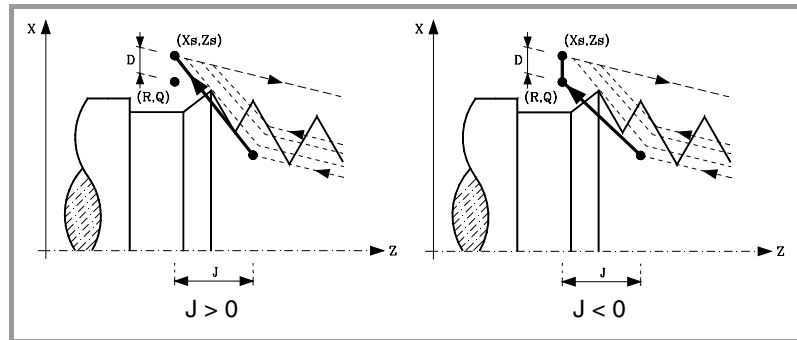

A±5.5

Defines the penetration angle of the tool. It is referred to the X axis and if not programmed, a value of 30° will be taken.

- If $A=0$ is programmed, the thread will be made with radial penetration.
- If the value assigned to parameter "A" is half the tool angle, the penetration will be done rubbing the thread's flank.
- If A is programmed with a negative value, the penetration will be done alternating the flanks of the thread.

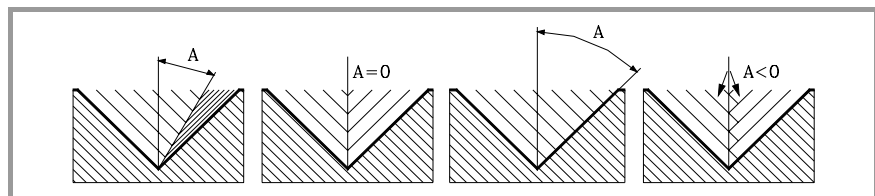

W±5.5

Optional. Its meaning depends on parameter "K".

- If "K" has been defined, it is a thread repair cycle. It indicates the angular spindle position corresponding to the thread measuring point.

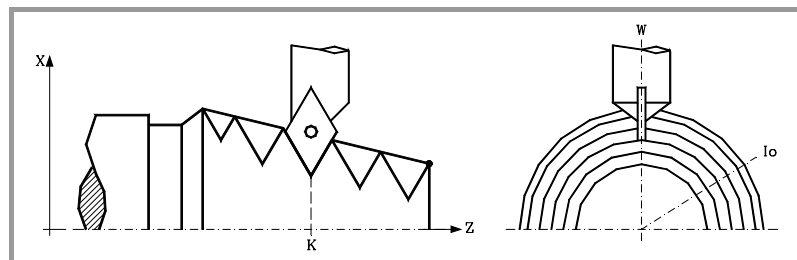

- If parameter "K" has not been defined, it indicates the angular position of the spindle corresponding to the thread's starting point. This allows making multi-entry threads without using the parameter "V".

The following example shows how to make a 3-entry-point thread. To do that, 3 threading canned cycles will be programmed with the same values except for "W".

```
G86 X Z Q R K I B E D L C J A W0
G86 X Z Q R K I B E D L C J A W120
G86 X Z Q R K I B E D L C J A W240
```

9.
CANNED CYCLES
 G86. Longitudinal threading canned cycle



CNC 8055
CNC 8055i

.T- MODEL
(SOFT V16.1X)

V±5.5 Optional. It sets the desired number of thread entries.

If not programmed or defined with a 0 value, the thread will only have one entry.

M±5.5 It defines the thread pitch increment (positive M) or decrement (negative M) per spindle revolution.

This parameter is incompatible with parameter K (thread repair); therefore, if both parameters are programmed together, the CNC will display the pertinent error message.



It must be borne in mind that if a thread pitch decrement is programmed and the pitch reaches 0 before the end of the thread cutting operation, the CNC will display the corresponding error message.

9.

CANNED CYCLES

G86. Longitudinal threading canned cycle



**CNC 8055
CNC 8055i**

.T- MODEL
(SOFT V16.1X)

9.9.1 Basic operation

9.

CANNED CYCLES
G86. Longitudinal threading canned cycle

1. Rapid move (G00) to the approach point located at a safety distance "D" from the initial point (X, Z).
2. Threading loop. The following steps will be repeated until the finishing coordinate is reached; programmed depth "I" minus the finishing stock "L".
 - 1- Rapid move (G00) to the programmed depth indicated by "B". This move will be made according to the penetration angle of the selected tool (A).
 - 2- Performs the threading of the programmed section with the selected exit "J". The feedrate F cannot be varied with the feedrate override switch while threading; it will stay at 100%. At the beginning of the machining operation on large lathes, when cutting long threads, the spindle speed may be overridden in the first passes to prevent the part from bending.
 - 3- Withdrawal in rapid (G00) to the approach point.
3. Thread finishing. Rapid move (G00) to the programmed depth coordinate "I". This move will be radial or according to the tool penetration angle (A) which depends on the sign assigned to parameter "L".
4. Performs the threading of the programmed section with the selected exit "J". The feedrate F cannot be varied with the feedrate override switch while threading; it will stay at 100%. It will not be possible to vary the spindle speed override in the last threading pass, it will be set to the value imposed in the previous pass.
5. Withdrawal in rapid (G00) to the approach point.

Thread repair

To do a thread repair, proceed as follows:

1. Home (reference) the spindle.
2. Measure the angle of the root of the thread, K W parameters.
3. Define the G87 cycle for thread repair.
4. Execute the canned cycle.

Considerations

The machining conditions (feedrate, spindle speed, etc.) must be programmed before calling the cycle.

Once the canned cycle has ended, the program will continue with the same feedrate F and G functions active previous to calling the cycle. Only the tool radius compensation will be cancelled (G40) if it was active.



CNC 8055
CNC 8055i

·T· MODEL
(SOFT V16.1x)

9.10 G87. Face threading canned cycle

With this cycle it is possible to cut outside or inside threads on the face of the part.

The right-hand and left-hand threads will be programmed by indicating the direction of the spindle rotation M03 or M04.

The basic structure of the block is as follows:

G87 X Z Q R K I B E D L C J A W V M

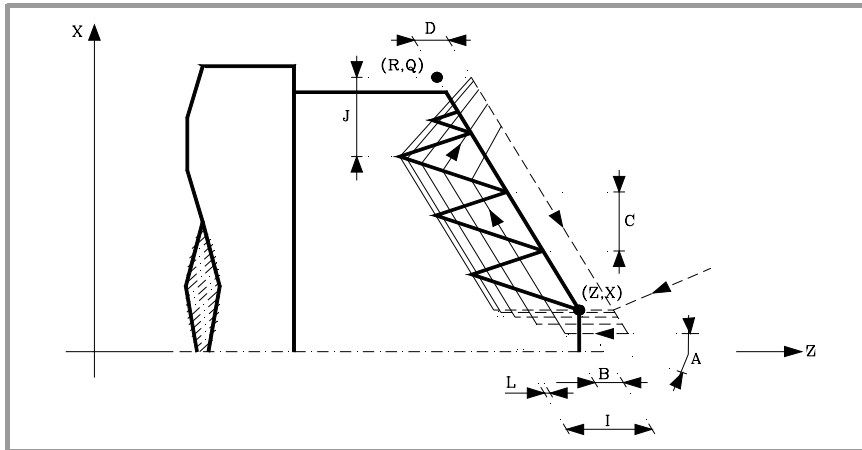

- X±5.5** Defines the X coordinate of the initial point of the thread. It must be programmed in absolute coordinates and in the active units, radius or diameter.
- Z±5.5** Defines the Z coordinate of the initial point of the thread. It must be programmed in absolute coordinates.
- Q±5.5** Defines the X coordinate of the final point of the thread. It must be programmed in absolute coordinates and in the active units, radius or diameter.
- R±5.5** Defines the Z coordinate of the final point of the thread.
- K±5.5** Optional. It is used with parameter "W" for thread repair.
Defines the Z coordinate of the point where the thread is to be measured. Usually it is an intermediate point of the thread.
- I±5.5** Defines the depth of the thread. Its value will be positive if threading in the negative Z direction and vice versa.
If programmed with a 0 value, the CNC will display the corresponding error message.
- B±5.5** Defines the depth of the threading passes and it is given in radius.

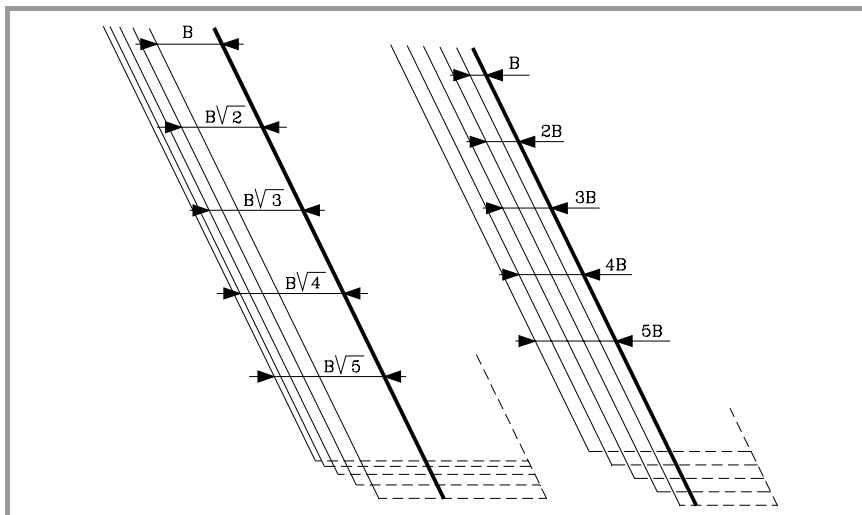

9.

CANNED CYCLES
G87. Face threading canned cycle

FAGOR 

CNC 8055
CNC 8055i

·T· MODEL
(SOFT V16.1X)

9.

CANNED CYCLES
G87. Face threading canned cycle

- If a positive value is programmed, the depth of each pass will depend on the number of the corresponding pass.

This way, the penetrations along the Z axis are:

$$B, B\sqrt{2}, B\sqrt{3}, B\sqrt{4}, \dots, B\sqrt{n}$$

- If a negative value is programmed, the passes will have the same depth with a value equal to the one programmed (B).

This way, the penetrations along the Z axis are:

$$B, 2B, 3B, 4B, \dots, nB$$

- If programmed with a 0 value, the CNC will display the corresponding error message.

Regardless of the sign assigned to "B", when the last roughing pass (before finishing) is smaller than the programmed amount, the canned cycle will run a pass equal to the residual stock.

E±5.5 It is related to parameter "B".

It indicates the minimum value to be reached the penetration pitch when parameter "B" has been programmed with a positive value.

If not programmed, a value of 0 is assumed.

D±5.5 Defines the safety distance and it indicates at what distance, along Z, from the initial point must the tool be positioned in the approach move.

The return to the initial point after each pass will be carried out maintaining this distance (D) from the programmed section.

- If the programmed value is positive, this withdrawal will be performed in round corner (G05) and if negative, in square corner (G07).
- If not programmed, a value of 0 is assumed.

L±5.5 Defines the finishing pass

- If a positive value is programmed, the finishing pass will be performed maintaining the same penetration angle "A" as for the other passes.

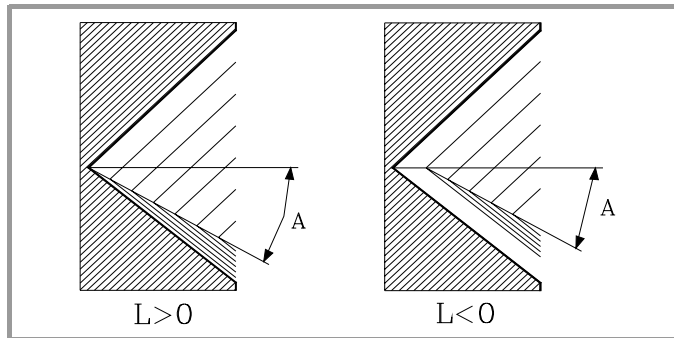

- If a negative value is programmed, the finishing pass will be carried out with radial penetration.
- If a value of 0 is programmed, the previous pass is repeated.



CNC 8055
CNC 8055i

.T- MODEL
(SOFT V16.1x)

C5.5 Defines the thread's pitch.

- With a positive sign if the pitch is programmed along the taper.
- With a negative sign if the pitch is programmed along the associated axis.

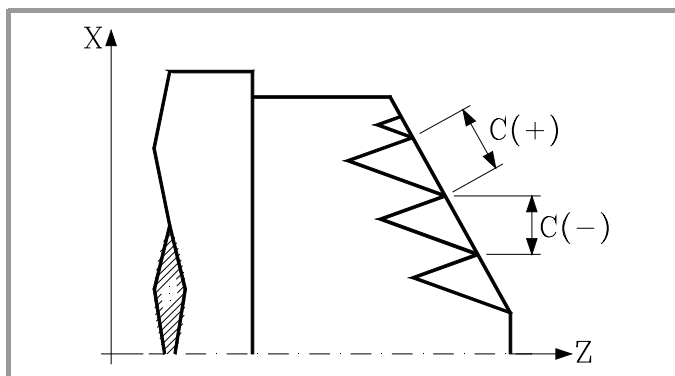

If programmed with a 0 value, the CNC will display the corresponding error message.

J5.5

Exit from the thread. It defines at what distance from the final point (R, Q), along the Z axis, starts the withdrawal from the thread.

- If programmed with a positive value, the tool moves directly from point "J" to the safety distance X_s, Z_s .
- If programmed with a negative value, the tool moves from point "J" to the end of the thread (R, Q) and then to the safety distance X_s .
- If not programmed, a value of 0 is assumed (blind thread).

The third set of gains and accelerations for the axes and the spindle may be used to improve the adjustment and the machining of the exit from blind threads. If the thread exit is a short distance, any acceleration set may be used or even remove the acceleration without getting the error "insufficient acceleration while threading".

We recommend to use low or no acceleration.

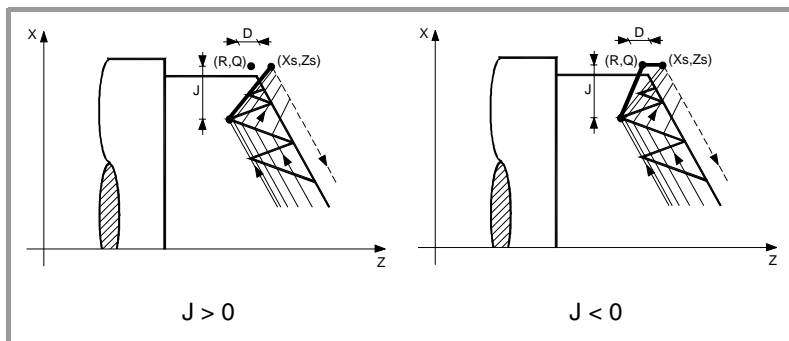

A±5.5

Defines the penetration angle of the tool. It is referred to the X axis and if not programmed, a value of 30° will be taken.

- If $A=0$ is programmed, the thread will be made with radial penetration.
- If the value assigned to parameter "A" is half the tool angle, the penetration will be done rubbing the thread's flank.
- If A is programmed with a negative value, the penetration will be done alternating the flanks of the thread.

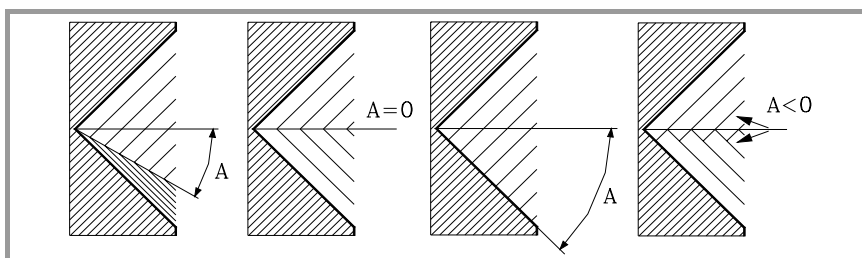

W±5.5

Optional. Its meaning depends on parameter "K".

- If "K" has been defined, it is a thread repair cycle. It indicates the angular spindle position corresponding to the thread measuring point.

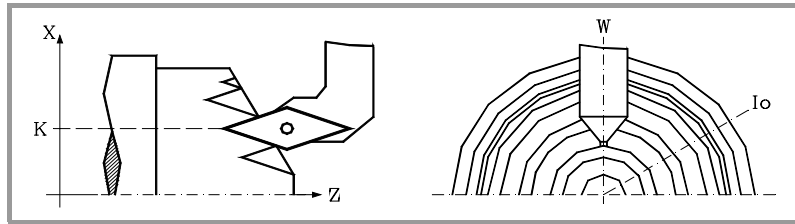

- If parameter "K" has not been defined, it indicates the angular position of the spindle corresponding to the thread's starting point. This allows making multi-entry threads without using the parameter "V".

The following example shows how to make a 3-entry-point thread. To do that, 3 threading canned cycles will be programmed with the same values except for "W".

```
G86 X Z Q R K I B E D L C J A W0
G86 X Z Q R K I B E D L C J A W120
G86 X Z Q R K I B E D L C J A W240
```

V±5.5

Optional. It sets the desired number of thread entries.

If not programmed or defined with a 0 value, the thread will only have one entry.

M±5.5

It defines the thread pitch increment (positive M) or decrement (negative M) per spindle revolution.

This parameter is incompatible with parameter K (thread repair); therefore, if both parameters are programmed together, the CNC will display the pertinent error message.



It must be borne in mind that if a thread pitch decrement is programmed and the pitch reaches 0 before the end of the thread cutting operation, the CNC will display the corresponding error message.

9.
CANNED CYCLES
G87. Face threading canned cycle



CNC 8055
CNC 8055i

.T- MODEL
(SOFT V16.1x)

9.10.1 Basic operation

1. Rapid move (G00) to the approach point located at a safety distance "D" from the initial point (X, Z).
2. Threading loop. The following steps will be repeated until the finishing coordinate is reached; programmed depth "I" minus the finishing stock "L".
 - .1. Rapid move (G00) to the programmed depth indicated by "B". This move will be made according to the penetration angle of the selected tool (A).
 - .2. Performs the threading of the programmed section with the selected exit "J". The feedrate F cannot be varied with the feedrate override switch while threading; it will stay at 100%. At the beginning of the machining operation on large lathes, when cutting long threads, the spindle speed may be overridden in the first passes to prevent the part from bending.
 - .3. Withdrawal in rapid (G00) to the approach point.
3. Thread finishing. Rapid move (G00) to the programmed depth coordinate "I". This move will be radial or according to the tool penetration angle (A) which depends on the sign assigned to parameter "L".
4. Performs the threading of the programmed section with the selected exit "J". The feedrate F cannot be varied with the feedrate override switch while threading; it will stay at 100%. It will not be possible to vary the spindle speed override in the last threading pass, it will be set to the value imposed in the previous pass.
5. Withdrawal in rapid (G00) to the approach point.

Thread repair

To do a thread repair, proceed as follows:

1. Home (reference) the spindle.
2. Measure the angle of the root of the thread, K W parameters.
3. Define the G87 cycle for thread repair.
4. Execute the canned cycle.

Considerations

The machining conditions (feedrate, spindle speed, etc.) must be programmed before calling the cycle.

Once the canned cycle has ended, the program will continue with the same feedrate F and G functions active previous to calling the cycle. Only the tool radius compensation will be cancelled (G40) if it was active.

9.

CANNED CYCLES
G87. Face threading canned cycle



CNC 8055
CNC 8055i

.T- MODEL
(SOFT V16.1X)

9.11 G88. X axis grooving canned cycle

This cycle performs a grooving operation along the X axis maintaining the same pass between the successive passes being this equal to or smaller than the one programmed.

The basic structure of the block is as follows:

G88 X Z Q R C D K

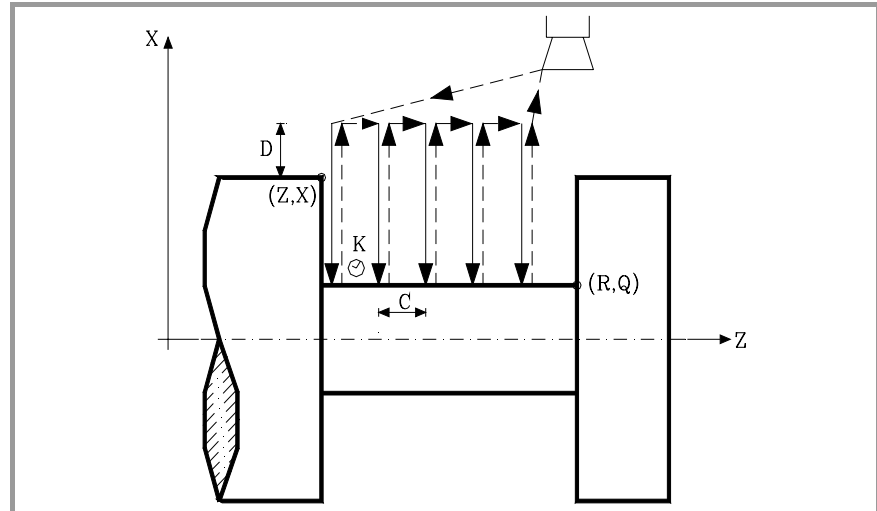

- X±5.5** Defines the X coordinate of the initial point of the groove. It must be programmed in absolute coordinates and in the active units, radius or diameter.
- Z±5.5** Defines the Z coordinate of the initial point of the groove. It must be programmed in absolute coordinates.
- Q±5.5** Defines the X coordinate of the final point of the groove. It must be programmed in absolute coordinates and in the active units, radius or diameter.
- R±5.5** Defines the Z coordinate of the final point of the groove.
- C5.5** Defines the grooving pass.
If not programmed, the CNC will assume the width of the cutter (NOSEW) of the active tool and if programmed with a zero value, the CNC will issue the corresponding error message.
- D5.5** Defines the safety distance and it must have a positive value in radius.
- K5** Defines the dwell, in hundredths of a second, after each penetration until the withdrawal begins.
If not programmed, a value of 0 is assumed.

9.
CANNED CYCLES
 G88. X axis grooving canned cycle



CNC 8055
CNC 8055i

.T- MODEL
(SOFT V16.1x)

9.11.1 Basic operation

The whole grooving operation is done with the same pass being this equal to or smaller than "C". Each grooving pass is carried out in the following manner:

- The penetration is done at programmed feedrate (F).
- The withdrawal and the move to the next penetration point are done in rapid (G00).

After completing the grooving operation, the canned cycle will always end at the cycle calling point.

Considerations

The machining conditions (feedrate, spindle speed, etc.) must be programmed before calling the cycle.

Once the canned cycle has ended, the program will continue with the same feedrate F and G functions active previous to calling the cycle. Only the tool radius compensation will be cancelled (G40) if it was active.

The tool must be located at a distance, along X, equal to or greater than the one indicated by canned cycle parameter "D" (safety distance) with respect to the part.

If the depth of the groove is 0, the CNC will display the corresponding error message.

If the width of the groove is smaller than the width of the cutter (NOSEW), the CNC will display the corresponding error message.

9.

CANNED CYCLES

G88. X axis grooving canned cycle

FAGOR 

**CNC 8055
CNC 8055i**

·T· MODEL
(SOFT V16.1X)

9.12 G89. Z axis grooving canned cycle

This cycle performs a grooving operation along the Z axis maintaining the same pass between the successive passes being this equal to or smaller than the one programmed.

The basic structure of the block is as follows:

G89 X Z Q R C D K

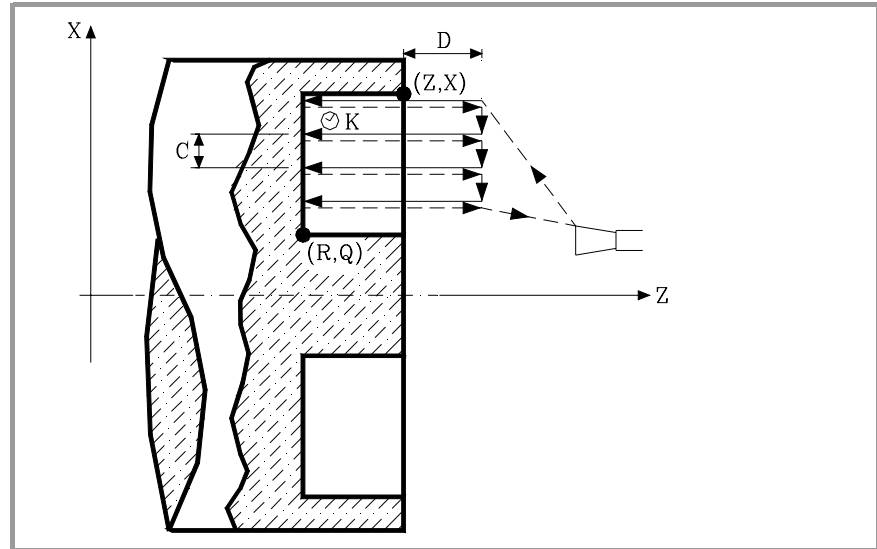

- X±5.5** Defines the X coordinate of the initial point of the groove. It must be programmed in absolute coordinates and in the active units, radius or diameter.
- Z±5.5** Defines the Z coordinate of the initial point of the groove. It must be programmed in absolute coordinates.
- Q±5.5** Defines the X coordinate of the final point of the groove. It must be programmed in absolute coordinates and in the active units, radius or diameter.
- R±5.5** Defines the Z coordinate of the final point of the groove.
- C5.5** Defines the grooving pass. It is programmed in radius.
If not programmed, the CNC will assume the width of the cutter (NOSEW) of the active tool and if programmed with a zero value, the CNC will issue the corresponding error message.
- D5.5** Defines the safety distance.
If not programmed, a value of 0 is assumed.
- K5** Defines the dwell, in hundredths of a second, after each penetration until the withdrawal begins.
If not programmed, a value of 0 is assumed.



CNC 8055
CNC 8055i

.T- MODEL
(SOFT V16.1x)

9.12.1 Basic operation

The whole grooving operation is done with the same pass being this equal to or smaller than "C". Each grooving pass is carried out in the following manner:

- The penetration is done at programmed feedrate (F).
- The withdrawal and the move to the next penetration point are done in rapid (G00).

After completing the grooving operation, the canned cycle will always end at the cycle calling point.

Considerations

The machining conditions (feedrate, spindle speed, etc.) must be programmed before calling the cycle.

Once the canned cycle has ended, the program will continue with the same feedrate F and G functions active previous to calling the cycle. Only the tool radius compensation will be cancelled (G40) if it was active.

The tool must be located at a distance, along Z, equal to or greater than the one indicated by canned cycle parameter "D" (safety distance) with respect to the part.

If the depth of the groove is 0, the CNC will display the corresponding error message.

If the width of the groove is smaller than the width of the cutter (NOSEW), the CNC will display the corresponding error message.

9.

CANNED CYCLES

G89. Z axis grooving canned cycle

FAGOR 

**CNC 8055
CNC 8055i**

·T· MODEL
(SOFT V16.1X)

9.13 G60. Axial drilling / tapping (on the face)

This cycle is available when the machine has a live tool.

This cycle may be used to carry out axial drilling or axial tapping. Whether one operation or the other will be performed depends on the format being used. Set parameter "B=0" for tapping and "B>0" for drilling.

While drilling or tapping, the spindle is stopped and the tool is turning. This makes it possible to machine anywhere on the workpiece.

The basic block structure for each operation is:

Drilling G60 X Z I B Q A J D K H C S L R

Tapping G60 X Z I B0 Q A J D S R

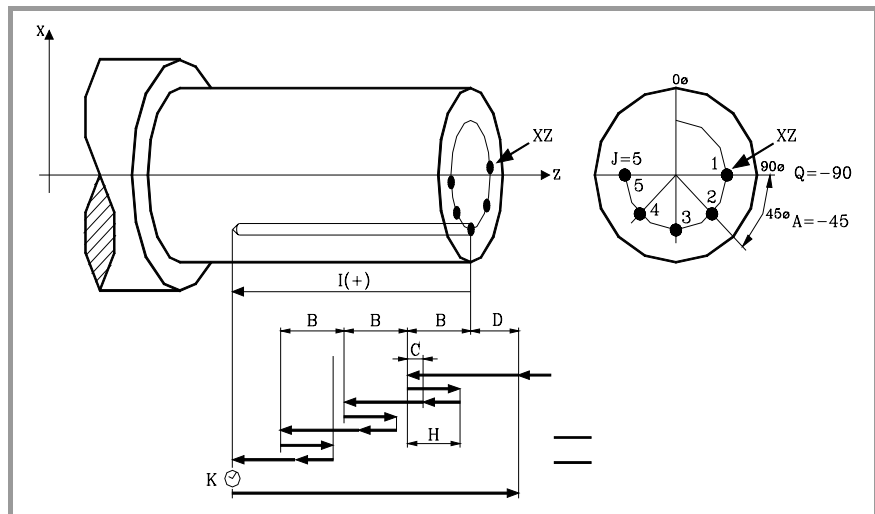

X±5.5 Defines the X coordinate where the cycle is to be run. It must be programmed in absolute coordinates and in the active units, radius or diameter.

Z±5.5 Defines the Z coordinate where the cycle will be run. It must be programmed in absolute coordinates.

I±5.5 Defines the total depth. It is referred to the drilling point (X, Z); thus, it will have a positive value when drilling in the negative Z direction and vice versa.

If programmed with a 0 value, the CNC will display the corresponding error message.

B5.5 Defines the type of operation to be run.

- Set B=0 for tapping.
- B>0 for drilling, where B indicates the drilling step.

Q±5.5 Defines the first angular position to orient the spindle to drill or tap the first hole.

A±5.5 Defines the angular increment between two consecutive operations. It is programmed in degrees. Positive when counter-clockwise.

J4 Defines the number of holes to be drilled or tapped, including the first one.

If programmed with a 0 value, the CNC will display the corresponding error message.

9.

CANNED CYCLES
G60. Axial drilling / tapping (on the face)



CNC 8055
CNC 8055i

.T- MODEL
(SOFT V16.1X)

- D5.5** Defines the safety distance along the Z axis and indicates how far from the starting point (Z, X) the tool will approach the part. If not programmed, a value of 0 is assumed.
- K5** Defines the dwell, in hundredths of a second, at the bottom of the hole before starting the withdrawal. If not programmed, a value of 0 is assumed.
- The tapping operation ignores this parameter, thus not being necessary to program it. If programmed, it will be ignored.
- H5.5** Defines the rapid (in G00) withdrawing distance along the Z axis after each drilling peck. If not programmed or programmed a value of 0, it will withdraw to the approach point.
- The tapping operation ignores this parameter, thus not being necessary to program it. If programmed, it will be ignored.
- C5.5** Defines the rapid approaching distance for successive drilling pecks. If not programmed, a value of 1 millimeter.
- The tapping operation ignores this parameter, thus not being necessary to program it. If programmed, it will be ignored.
- S±5.5** RPM and turning direction (sign) of the live tool.
- L5.5** Optional. In the drilling cycle, it defines the minimum drilling peck. It is used with "R" values other than 1.
- If not programmed, a value of 0 is assumed.
- R5.5** In the drilling cycle, it indicates the step that reduces the drilling peck "B". If it is not programmed or is programmed with a value of "0", it assumes a value of "1".
- With R =1, all the drilling pecks will be the same (the programmed "B" value).
 - If R is other than 1, the first drilling peck will be "B", the second one "R B", The third one "R (RB)" and so on. In other words, from the second peck on, the new peck will be the product of the R factor times the previous peck.
- In the tapping cycle, it defines the type of tapping. "R0" means regular tapping cycle and "R1" means rigid tapping. If not programmed, it takes the value of "0", regular tapping.
- In order to execute a rigid tapping, the relevant spindle (main or secondary) must be ready to operate in closed loop. In other words, that it must have a servo drive-motor system with rotary encoder.

9.

CANNED CYCLES
G60. Axial drilling / tapping (on the face)

FAGOR 

CNC 8055
CNC 8055i

·T· MODEL
(SOFT V16.1X)

9.13.1 Basic operation

9.

CANNED CYCLES
G60. Axial drilling / tapping (on the face)

Drilling

1. Rapid move to the approach point located at a "D" distance from the first hole position.
2. The CNC turns on the live tool at the rpm and in the turning direction indicated by parameter "S".
3. Orients the spindle at the angular position set by "Q". If the spindle was turning, it will stop.
4. First drilling operation. The drilling axis moves in G01 to the programmed incremental depth "D+B".
5. Drilling loop. The following steps will be repeated until the programmed depth "I" is reached.
 - .1. Withdrawal in rapid (G00) a distance "H" or to the approach point.
 - .2. Rapid approach (G00) to a "C" distance from the next peck.
 - .3. New drilling step. G1 move to the next incremental depth "B and R".
6. Dwell "K" at the bottom of the hole in hundredths of a second, if programmed.
7. Withdrawal in rapid (G00) to the approach point.
8. Depending on the value assigned to "J" (number of holes to be drilled):
 - .1. The spindle turns to a new position. Angular increment "A".
 - .2. Repeats the movements indicated in steps 4, 5, 6 and 7.
9. The live tool stops.

Tapping

1. Rapid move to the approach point located at a "D" distance from the first hole position.
2. The CNC turns on the live tool at the rpm and in the turning direction indicated by parameter "S".
3. Orients the spindle at the angular position set by "Q". If the spindle was turning, it will stop.
4. Tapping. Movement of the tapping axis to the bottom of the hole "I". MFO, SSO, FEED-HOLD and CYCLE STOP are disabled.
5. Reversal of the turning direction of the live tool.
6. Withdrawal in work feedrate to the approach point.
7. Depending on the value assigned to "J" (number of holes to be tapped).
 - .1. The spindle turns to a new position. Angular increment "A".
 - .2. Repeats the movements indicated in steps 4, 5, 6 and 7.
8. The live tool stops.



CNC 8055
CNC 8055i

.T- MODEL
(SOFT V16.1x)

Rigid tapping

1. Rapid movement to the approach point located at a safety distance "D" from the tap point.
2. Orients the spindle at the angular position set by "Q". If the spindle was turning, it will stop.
3. Tapping. Interpolation of the second spindle (live tool) with the Z axis.
The second spindle must have an encoder and general machine parameter AUXTYPE must be at "1" (otherwise, it issues error 1042: Wrong parameter value in the canned cycle).
The feedrate "F" must be programmed before the cycle and the spindle speed "S" is implicit in the definition of the cycle. The cycle assumes functions G94 and G97.
Rigid tapping cannot be interrupted, nor the machining conditions be changed. It is done at 100% of the programmed "S" and "F".
4. Reversal of the turning direction of the live tool.
5. Withdrawal in work feedrate to the approach point.
6. Depending on the value assigned to "J" (number of holes to be tapped).
 - .1. The spindle turns to a new position. Angular increment "A".
 - .2. Repeats the movements indicated in steps 4, 5, 6 and 7.
7. The live tool stops.

Rigid tapping is drawn with the color used for "uncompensated tool path".

When the cycle is completed, the second spindle stops (M5). The main spindle keeps working in M19.

Considerations

The machining conditions (feedrate, live tool rpm, etc.) must be programmed prior to the calling the cycle.

If when executing the cycle, it is working in G95 and it has not been working in G94 before, the CNC shows "error 1039. The F has not been programmed in G94".

When tapping (regular or rigid), the general logic output "TAPPING" (M5517) stays active during the execution of the cycle.

Once the canned cycle has ended, the program will continue with the same feedrate F and G functions active previous to calling the cycle. Only the tool radius compensation will be cancelled (G40) if it was active.

9.

CANNED CYCLES

G60. Axial drilling / tapping (on the face)

FAGOR
**CNC 8055
CNC 8055i**

 ·T· MODEL
(SOFT V16.1X)

9.14 G61. Radial drilling/ tapping (on the side of the part)

This cycle is available when the machine has a live tool.

This cycle may be used to carry out axial drilling or axial tapping. Whether one operation or the other will be performed depends on the format being used. Set parameter "B=0" for tapping and "B>0" for drilling.

While drilling or tapping, the spindle is stopped and the tool is turning. This makes it possible to machine anywhere on the workpiece.

The basic block structure for each operation is:

Drilling G61 X Z I B Q A J D K H C S L R

Tapping G61 X Z I B0 Q A J D S R

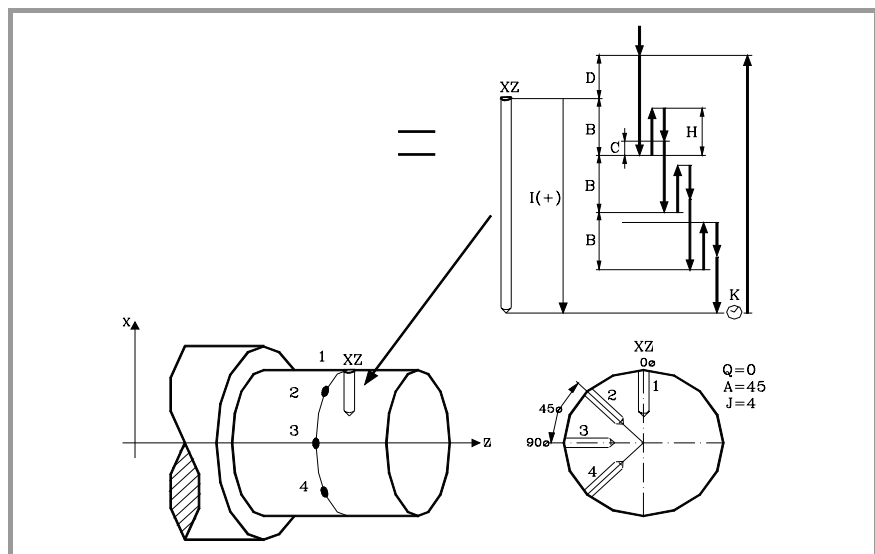

- X±5.5** Defines the X coordinate where the cycle is to be run. It must be programmed in absolute coordinates and in the active units, radius or diameter.
- Z±5.5** Defines the Z coordinate where the cycle will be run. It must be programmed in absolute coordinates.
- I±5.5** Defines the depth in radius. It is referred to the drilling point (X, Z); thus, it will have a positive value when drilling in the negative X direction and vice versa.
If programmed with a 0 value, the CNC will display the corresponding error message.
- B5.5** Defines the type of operation to be run.
- Set B=0 for tapping.
 - B>0 for drilling, where B indicates the drilling step in radius.
- Q±5.5** Defines the first angular position to orient the spindle to drill or tap the first hole.
- A±5.5** Defines the angular increment between two consecutive operations. It is programmed in degrees. Positive when counter-clockwise.
- J4** Defines the number of holes to be drilled or tapped, including the first one.
If programmed with a 0 value, the CNC will display the corresponding error message.

9.

CANNED CYCLES
G61. Radial drilling/ tapping (on the side of the part)



CNC 8055
CNC 8055i

.T- MODEL
(SOFT V16.1X)

- D5.5** Defines (in radius) the safety distance along the X axis and indicates how far from the starting point (Z, X) the tool will approach the part. If not programmed, a value of 0 is assumed.
- K5** Defines the dwell, in hundredths of a second, at the bottom of the hole before starting the withdrawal. If not programmed, a value of 0 is assumed.
- The tapping operation ignores this parameter, thus not being necessary to program it. If programmed, it will be ignored.
- H5.5** Defines (in radius) the rapid (in G00) withdrawing distance along the X axis after each drilling peck. If not programmed or programmed a value of 0, it will withdraw to the approach point.
- The tapping operation ignores this parameter, thus not being necessary to program it. If programmed, it will be ignored.
- C5.5** Defines (in radius) the rapid approaching distance for successive drilling pecks. If not programmed, a value of 1 millimeter.
- The tapping operation ignores this parameter, thus not being necessary to program it. If programmed, it will be ignored.
- S±5.5** RPM and turning direction (sign) of the live tool.
- L5.5** Optional. In the drilling cycle, it defines the minimum drilling peck. It is used with "R" values other than 1.
- If not programmed, a value of 0 is assumed.
- R5.5** In the drilling cycle, it indicates the step that reduces the drilling peck "B". If it is not programmed or is programmed with a value of "0", it assumes a value of "1".
- With R =1, all the drilling pecks will be the same (the programmed "B" value).
 - If R is other than 1, the first drilling peck will be "B", the second one "R B", The third one "R (RB)" and so on. In other words, from the second peck on, the new peck will be the product of the R factor times the previous peck.
- In the tapping cycle, it defines the type of tapping. "R0" means regular tapping cycle and "R1" means rigid tapping. If not programmed, it takes the value of "0", regular tapping.
- In order to execute a rigid tapping, the relevant spindle (main or secondary) must be ready to operate in closed loop. In other words, that it must have a servo drive-motor system with rotary encoder.

9.

CANNED CYCLES
G61. Radial drilling/ tapping (on the side of the part)



CNC 8055
CNC 8055i

·T· MODEL
(SOFT V16.1X)

9.14.1 Basic operation

9.

CANNED CYCLES
G61. Radial drilling/tapping (on the side of the part)

Drilling

1. Rapid move to the approach point located at a "D" distance from the first hole position.
2. The CNC turns on the live tool at the rpm and in the turning direction indicated by parameter "S".
3. Orients the spindle at the angular position set by "Q". If the spindle was turning, it will stop.
4. First drilling operation. The drilling axis moves in G01 to the programmed incremental depth "D" + "B".
5. Drilling loop. The following steps will be repeated until the programmed depth "I" is reached.
 - .1. Withdrawal in rapid (G00) a distance "H" or to the approach point.
 - .2. Rapid approach (G00) to a "C" distance from the next peck.
 - .3. New drilling step. G1 move to the next incremental depth "B and R".
6. Dwell "K" at the bottom of the hole in hundredths of a second, if programmed.
7. Withdrawal in rapid (G00) to the approach point.
8. Depending on the value assigned to "J" (number of holes to be drilled):
 - .1. The spindle turns to a new position. Angular increment "A".
 - .2. Repeats the movements indicated in steps 4, 5, 6 and 7.
9. The live tool stops.

Tapping

1. Rapid move to the approach point located at a "D" distance from the first hole position.
2. The CNC turns on the live tool at the rpm and in the turning direction indicated by parameter "S".
3. Orients the spindle at the angular position set by "Q". If the spindle was turning, it will stop.
4. Tapping. Movement of the tapping axis to the bottom of the hole "I".
5. Reversal of the turning direction of the live tool.
6. Withdrawal in work feedrate to the approach point.
7. Depending on the value assigned to "J" (number of holes to be tapped).
 - .1. The spindle turns to a new position. Angular increment "A".
 - .2. Repeats the movements indicated in steps 4, 5, 6 and 7.
8. The live tool stops.



CNC 8055
CNC 8055i

.T- MODEL
(SOFT V16.1X)

Rigid tapping

1. Rapid movement to the approach point located at a safety distance "D" from the tap point.
2. Orients the spindle at the angular position set by "Q". If the spindle was turning, it will stop.
3. Tapping. Interpolation of the second spindle (live tool) with the Z axis.
The second spindle must have an encoder and general machine parameter AUXTYPE must be at "1" (otherwise, it issues error 1042: Wrong parameter value in the canned cycle).
The feedrate "F" must be programmed before the cycle and the spindle speed "S" is implicit in the definition of the cycle. The cycle assumes functions G94 and G97.
Rigid tapping cannot be interrupted, nor the machining conditions be changed. It is done at 100% of the programmed "S" and "F".
4. Reversal of the turning direction of the live tool.
5. Withdrawal in work feedrate to the approach point.
6. Depending on the value assigned to "J" (number of holes to be tapped).
 - .1. The spindle turns to a new position. Angular increment "A".
 - .2. Repeats the movements indicated in steps 4, 5, 6 and 7.
7. The live tool stops.

Rigid tapping is drawn with the color used for "uncompensated tool path".

When the cycle is completed, the second spindle stops (M5). The main spindle keeps working in M19.

Considerations

The machining conditions (feedrate, live tool rpm, etc.) must be programmed prior to the calling the cycle.

If when executing the cycle, it is working in G95 and it has not been working in G94 before, the CNC shows "error 1039. The F has not been programmed in G94".

When tapping (regular or rigid), the general logic output "TAPPING" (M5517) stays active during the execution of the cycle.

Once the canned cycle has ended, the program will continue with the same feedrate F and G functions active previous to calling the cycle. Only the tool radius compensation will be cancelled (G40) if it was active.

9.

CANNED CYCLES

G61. Radial drilling/tapping (on the side of the part)

FAGOR
CNC 8055
CNC 8055i

 ·T· MODEL
 (SOFT V16.1X)

9.15 G62. Slot milling canned cycle on the side of the part

This cycle is available when the machine has a live tool.

While performing this operation, the spindle is stopped and the tool is turning. This makes it possible to machine anywhere on the workpiece.

The basic structure of the block is as follows:

G62 X Z L I Q A J D F S

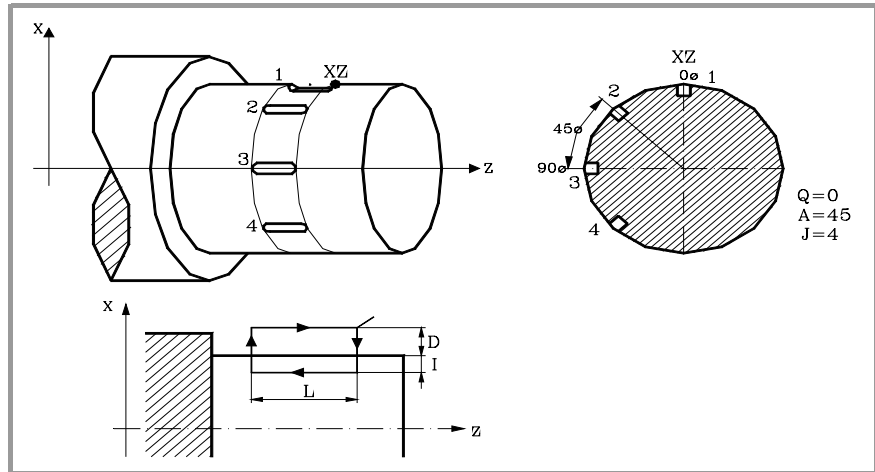

- X±5.5** Defines the X coordinate where the cycle is to be run. It must be programmed in absolute coordinates and in the active units, radius or diameter.
- Z±5.5** Defines the Z coordinate where the cycle will be run. It must be programmed in absolute coordinates.
- L±5.5** Defines the length of the slot. It is referred to the starting point (X, Z) and it will, therefore, have a positive value when machining in the negative Z direction and negative when doing it in the opposite direction. "L(+)" in the example above.
If programmed with a 0 value, the CNC will display the corresponding error message.
- I±5.5** Defines, in radius, the depth of the slot. It is referred to the starting point (X, Z).
If programmed with a 0 value, the CNC will display the corresponding error message.
- Q±5.5** Defines the angular position (in degrees) to orient the spindle to mill the first slot.
- A±5.5** Defines the angular increment between two consecutive operations. It is programmed in degrees. Positive when counter-clockwise.
- J 4** Defines the number of slots to be milled. If programmed with a 0 value, the CNC will display the corresponding error message.
- D5.5** Defines (in radius) the safety distance along the X axis and indicates how far from the starting point (Z, X) the tool will approach the part. If not programmed, a value of 0 is assumed.
- F5.5** Defines the slot milling feedrate.
- S±5.5** RPM and turning direction (sign) of the live tool.

9.

CANNED CYCLES
G62. Slot milling canned cycle on the side of the part



CNC 8055
CNC 8055i

.T- MODEL
(SOFT V16.1x)

9.15.1 Basic operation

1. Rapid approach up to the safety distance "D" from the slot milling point.
2. The CNC turns the live tool on at the rpm and turning direction set by parameter "S".
3. Orients the spindle at the angular position set by "Q". If the spindle was turning, it will stop.
4. Milling of the slot by following these steps:

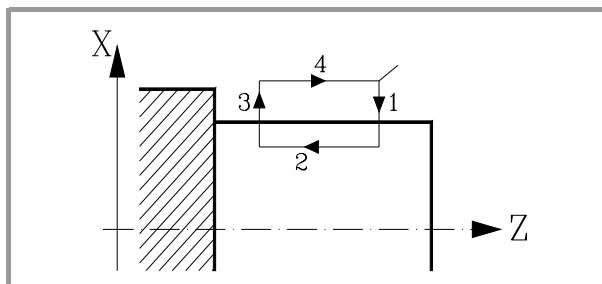

- .1. In feed at the feedrate selected prior to calling the cycle.
 - .2. Milling of the slot by moving the Z axis at the programmed "F" feedrate.
 - .3. Rapid withdrawal to the reference point.
 - .4. Rapid return to the starting point.
5. Depending on the setting of parameter "J" (number of slots):
 - .1. The spindle turns to a new position. Angular increment "A".
 - .2. Repeats the movements indicated on point 4.
 6. The live tool stops.

Considerations

The machining conditions (feedrate, live tool rpm, etc.) must be programmed prior to the calling the cycle.

If when executing the cycle, it is working in G95 and it has not been working in G94 before, the CNC shows "error 1039. The F has not been programmed in G94".

Once the canned cycle has ended, the program will continue with the same feedrate F and G functions active previous to calling the cycle. Only the tool radius compensation will be cancelled (G40) if it was active.

9.

CANNED CYCLES

G62. Slot milling canned cycle on the side of the part

FAGOR 

CNC 8055
CNC 8055i

.T- MODEL
(SOFT V16.1X)

9.16 G63. Slot milling canned cycle on the face of the part

This cycle is available when the machine has a live tool.

While performing this operation, the spindle is stopped and the tool is turning. This makes it possible to machine anywhere on the workpiece.

The basic structure of the block is as follows:

G63 X Z L I Q A J D F S

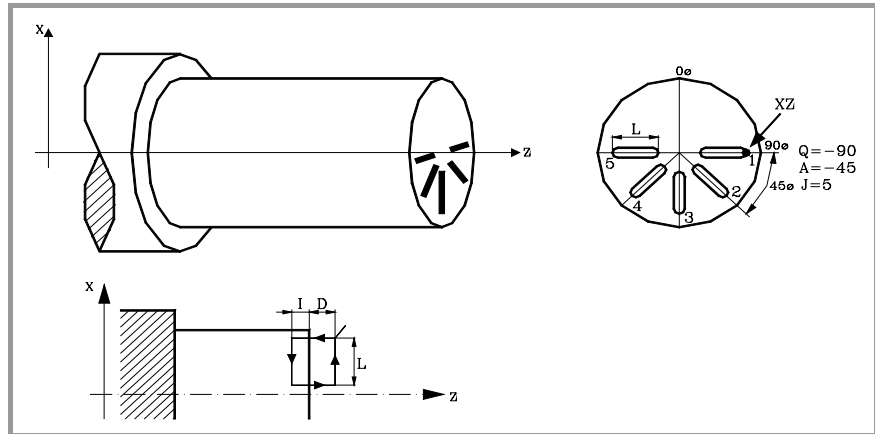

- X±5.5** Defines the X coordinate where the cycle is to be run. It must be programmed in absolute coordinates and in the active units, radius or diameter.
- Z±5.5** Defines the Z coordinate where the cycle will be run. It must be programmed in absolute coordinates.
- L±5.5** Defines, in radius, the length of the slot. It is referred to the starting point (X, Z) and it will, therefore, have a positive value when machining in the negative X direction and negative when doing it in the opposite direction. "L(+)" in the example above.
If programmed with a 0 value, the CNC will display the corresponding error message.
- I±5.5** Defines the depth of the slot. It is referred to the starting point (X, Z).
If programmed with a 0 value, the CNC will display the corresponding error message.
- Q±5.5** Defines the angular position (in degrees) to orient the spindle to mill the first slot.
- A±5.5** Defines the angular increment between two consecutive operations. It is programmed in degrees. Positive when counter-clockwise.
- D5.5** Defines the safety distance along the Z axis and indicates how far from the starting point (Z, X) the tool will approach the part. If not programmed, a value of 0 is assumed.
- J 4** Defines the number of slots to be milled. If programmed with a 0 value, the CNC will display the corresponding error message.
- F5.5** Defines the slot milling feedrate.
- S±5.5** RPM and turning direction (sign) of the live tool.

9.

CANNED CYCLES
G63. Slot milling canned cycle on the face of the part



CNC 8055
CNC 8055i

.T- MODEL
(SOFT V16.1x)

9.16.1 Basic operation

1. Rapid move to the approach point located at a "D" distance from the first hole position.
2. The CNC turns the live tool on at the rpm and turning direction set by parameter "S".
3. Orients the spindle at the angular position set by "Q". If the spindle was turning, it will stop.
4. Milling of the slot by following these steps:

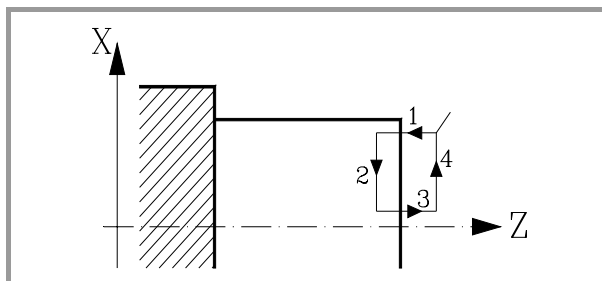

- .1. In feed at the feedrate selected prior to calling the cycle.
 - .2. Milling of the slot by moving the X axis at the programmed "F" feedrate.
 - .3. Rapid withdrawal to the reference point.
 - .4. Rapid return to the starting point.
5. Depending on the setting of parameter "J" (number of slots):
 6. The spindle turns to a new position. Angular increment "A".
 7. Repeats the movements indicated on point 4.
 8. The live tool stops.

Considerations

The machining conditions (feedrate, live tool rpm, etc.) must be programmed prior to the calling the cycle.

If when executing the cycle, it is working in G95 and it has not been working in G94 before, the CNC shows "error 1039. The F has not been programmed in G94".

Once the canned cycle has ended, the program will continue with the same feedrate F and G functions active previous to calling the cycle. Only the tool radius compensation will be cancelled (G40) if it was active.

9.

CANNED CYCLES

G63. Slot milling canned cycle on the face of the part

FAGOR 

CNC 8055
CNC 8055i

·T· MODEL
(SOFT V16.1x)

9.

CANNED CYCLES

G63. Slot milling canned cycle on the face of the part



CNC 8055
CNC 8055i

.T- MODEL
(SOFT V16.1X)

The CNC has two probe inputs, one for TTL-type 5Vdc signals and another for 24 Vdc signals.

The connection of the different types of probes to these inputs are explained in the appendix to the Installation manual.

This control allows the following operations to be performed, by using probes:

- Programming probing blocks with functions G75 and G76.
- Several tool calibration and part-measurement cycles by means of high-level language programming.

10.1 Probing (G75, G76)

10.

PROBING
Probing (G75, G76)

The G75 function allows movements to be programmed that will end after the CNC receives the signal from the measuring probe used.

The G76 function allows movements to be programmed that will end after the CNC no longer receives the signal from the measuring probe used.

Their definition format is:

```
G75 X..C ±5.5
```

```
G76 X..C ±5.5
```

After G75 or G76, the required axis or axes will be programmed, as well as the coordinates of these axes that will define the end point of the programmed movement.

The machine will move according to the programmed path until it receives the signal from the probe (G75) or until it no longer receives the probe signal (G76). At this time, the CNC will consider the block finished, taking as the theoretical position of the axes the real position they have at that time.

If the axes reach the programmed position before receiving or while receiving the external signal from the probe, the CNC will stop the movement of the axes.

This type of movement with probing blocks are very useful when it is required to generate measurement or verification programs for tools and parts.

Functions G75 and G76 are not modal and, therefore, must be programmed whenever it is wished to probe.

Functions G75 and G76 are incompatible with each other and with G00, G02, G03, G33, G34, G41 and G42 functions. In addition, once this has been performed, the CNC will assume functions G01 and G40.

During G75 or G76 moves, the operation of the feedrate override switch depends on the setting of OEM machine parameter FOVRG75.



CNC 8055
CNC 8055i

.T- MODEL
(SOFT V16.1X)

10.2 Probing canned cycles

The CNC offers the following probing canned cycles:

- Tool calibration canned cycle.
- Probe calibrating canned cycle.
- Canned cycle for part measuring and tool correction along the X axis.
- Canned cycle for part measuring and tool correction along the Z axis.

All the movements of these probing canned cycles will be performed in the X, Y, Z axes and the work plane must be formed by 2 of these axes (XY, XZ, YZ, YX, ZX, ZY). The other axis must be perpendicular and it must be selected as the longitudinal axis.

Canned cycles will be programmed by means of the high level mnemonic, PROBE, which has the following programming format:

```
(PROBE (expression), (assignment instruction),...)
```

This instruction PROBE calls the probing cycle indicated by means of a number or any expression which results in a number. Besides, it allows the parameters of this cycle to be initialized with the values required to perform it, by means of assignment instructions.

Some general points to consider

Probing canned cycles are not modal, and therefore must be programmed whenever it is required to perform any of them.

The probes used in the performance of these cycles are:

- Probe placed on a fixed position on the machine, used for calibrating tools.
- Probe placed in the spindle, will be treated as a tool and will be used in the different measuring cycles.

The execution of a probing canned cycle does not alter the history of previous "G" functions, except for the radius compensation functions G41 and G42.

10.

PROBING
Probing canned cycles

FAGOR 

CNC 8055
CNC 8055i

·T· MODEL
(SOFT V16.1X)

10.3 PROBE 1. Tool calibration canned cycle

10.

PROBING

PROBE 1. Tool calibration canned cycle

This is used to calibrate a tool or a probe located in the tool holder and to measure the wear of a tool.

Using the tool wear measuring operation, the user can define the maximum tool wear value. After several tool wear measuring probing operations, the wear will increase and when it exceeds the set maximum value, the tool will be rejected.

To perform this cycle it is necessary to have a table-top probe, installed in a fixed position on the machine and with its faces parallel to axes X, Y and Z. The probe position must be given in absolute coordinates referred to machine reference zero using the general machine parameters:

- PRBXMIN Indicates the minimum coordinate occupied by the probe along the X axis.
- PRBXMAX Indicates the maximum coordinate occupied by the probe along the X axis.
- PRBYMIN Indicates the minimum coordinate occupied by the probe along the Y axis.
- PRBYMAX Indicates the maximum coordinate occupied by the probe along the Y axis.
- PRBZMIN Indicates the minimum coordinate occupied by the probe along the Z axis.
- PRBZMAX Indicates the maximum coordinate occupied by the probe along the Z axis.

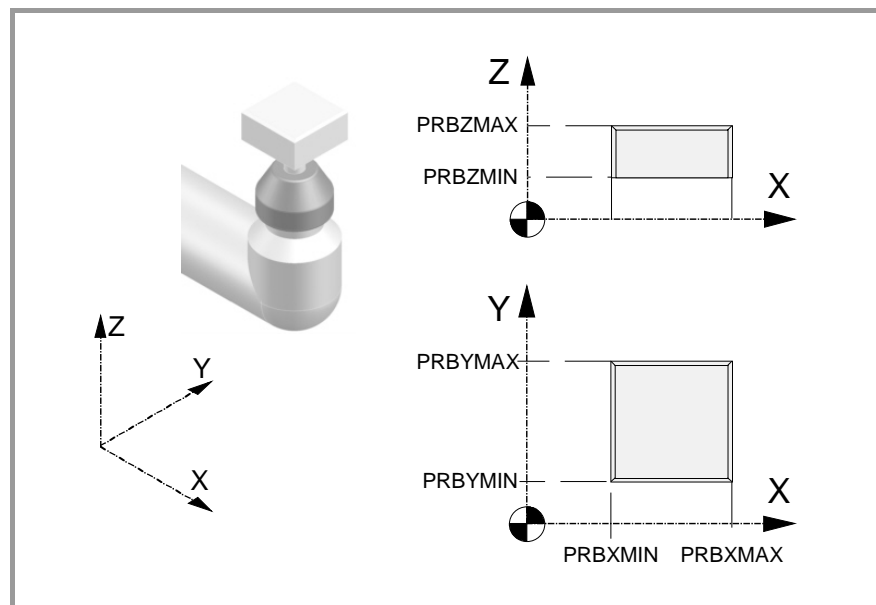

Tool calibration:

The correction is applied to the tool length updating its values in the X, Z and Y fields of the tool offset table.

Tool wear measurement:

The measured values are compared with the previous values of the X, Z and Y fields of the tool offset table and the difference is updated in the I, K and J fields.

Tool wear measurement is only available on CNC's that have the tool monitoring option.



CNC 8055
CNC 8055i

.T- MODEL
(SOFT V16.1x)

If it is the first time the tool or the probe is being calibrated, enter in the tool offset table an approximate length value (X, Z), location code (F) and the radius value (R). If it is a probe, the "R" value will correspond to the radius of the probe ball and the location code will depend on how it has been calibrated.

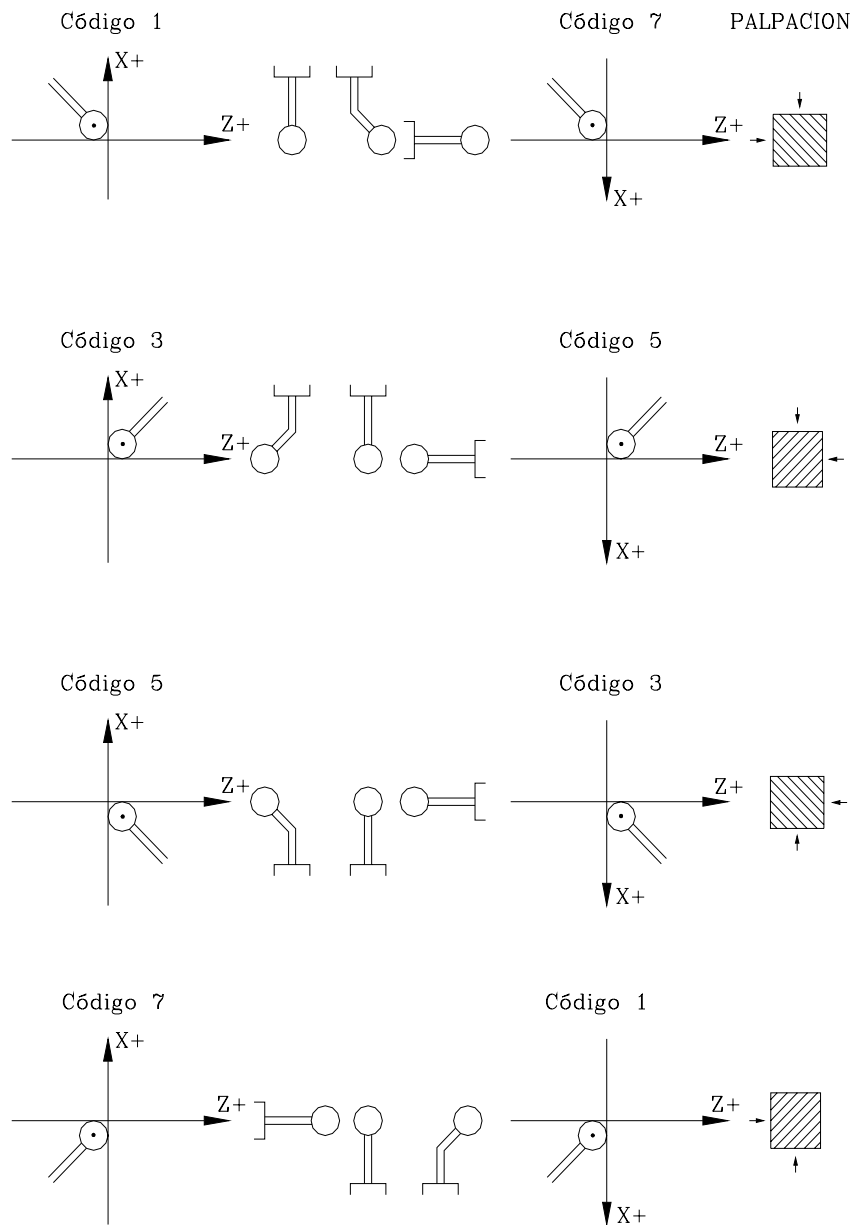

10.

PROBING
PROBE 1. Tool calibration canned cycle

Programming format

The programming format is as follows:

(PROBE 1, B, J, F, L, M, N, C, X, U, Y, V, Z, W)

B5.5

Safety distance

It defines the safety distance and it must be programmed with a positive value higher than 0 (zero). Its value is given in radius.



CNC 8055
CNC 8055i

·T· MODEL
(SOFT V16.1X)

J Type of operation

It may be used to select whether to calibrate a tool or measure tool wear.

J = 0 Tool calibration.

J=1 Wear measurement.

If not programmed, the cycle will assume the J0 value.

F5.5 Probing feedrate

It sets the probing feedrate. It must be programmed in mm/minute or inches/minute.

L5.5 Maximum length wear allowed on the X axis

When set to 0, the tool is not rejected due to length wear. The tool is rejected when measuring a wear greater than the one defined.

Only if J1 has been defined and tool life monitoring is being used. If this is not programmed, the canned cycle will take the value of L0.

M5.5 Maximum length wear allowed on the Z axis

When set to 0, the tool is not rejected due to length wear. The tool is rejected when measuring a wear greater than the one defined.

Only if J1 has been defined and tool life monitoring is being used. If not programmed, a value of M0 will be assumed.

N5.5 Maximum length wear allowed on the Y axis

When set to 0, the tool is not rejected due to length wear. The tool is rejected when measuring a wear greater than the one defined.

Only if J1 has been defined and tool life monitoring is being used. If not programmed, the canned cycle will assume the N0 value.

C Behavior when exceeding the amount of wear allowed

Only if "L", "M" or "N" has been set to other than zero.

C=0 It interrupts the execution for the user to select another tool.

C=1 The cycle replaces the tool with another one of the same family.

If not programmed, the cycle will assume the C0 value.

X U Y V Z W Probe position

Define the probe position. They are optional parameters that usually need not be defined. In certain machines, due to lack of repeatability in the mechanical positioning of the probe, the probe must be calibrated again before each calibration.

Instead of redefining machine parameters PRBXMIN, PRBXMAX, PRBYMIN, PRBYMAX, PRBZMIN and PRBZMAX every time the probe is calibrated, those coordinates may be indicated in parameters X, U, Y, V, Z and W, respectively.

The CNC does not modify the machine parameters. The CNC only takes into account the coordinates indicated in X, U, Y, V, Z, W during this calibration. If any of the X, U, Y, V, Z, W fields is left out, the CNC takes the value assigned to the corresponding machine parameter.

10.

PROBING
PROBE 1. Tool calibration canned cycle



CNC 8055
CNC 8055i

.T- MODEL
(SOFT V16.1x)

10.3.1 Basic operation

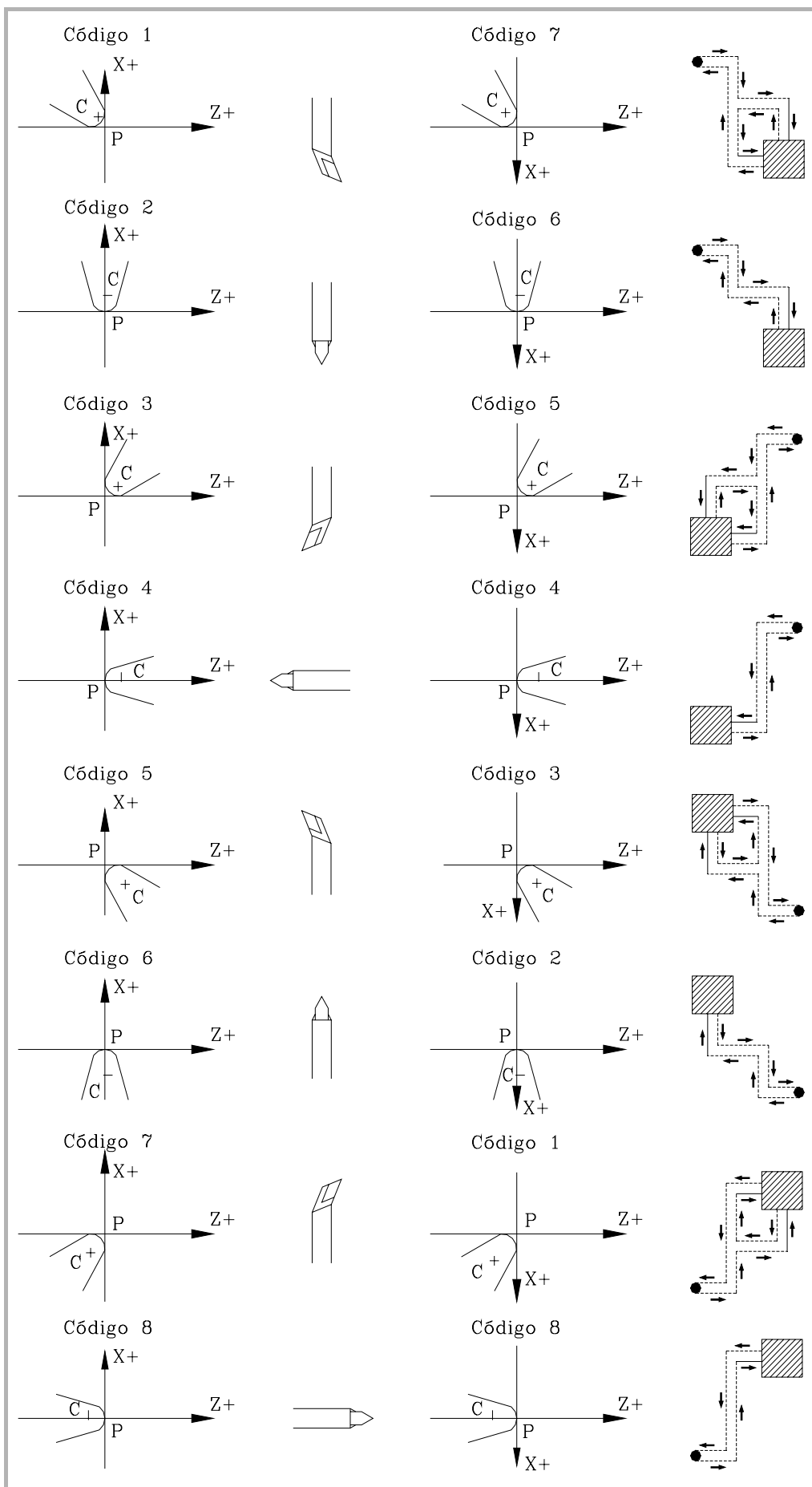

10.

PROBING
PROBE 1. Tool calibration canned cycle



CNC 8055
CNC 8055i

·T· MODEL
(SOFT V16.1x)

10.

PROBING

PROBE 1. Tool calibration canned cycle

1. Approach movement.

Rapid tool movement (G00) from the cycle calling point to the approach point. This point is located in front of the corresponding probe corner, at a safety distance (B) from both sides.

The approach movement is made in two stages. It first moves along the Z axis and then along the X axis.

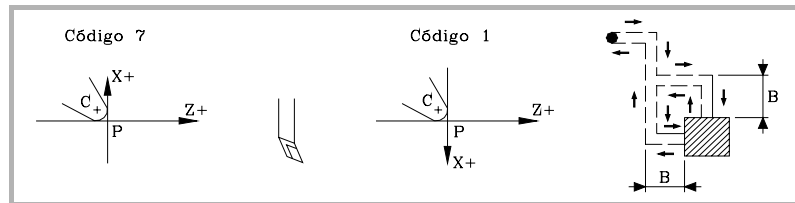

2. Probing.

Depending on the location code assigned to the selected tool, 1 or 2 probing moves will be made to calibrate it. Each probing move will consist of an approach move, a probing move per se and a withdrawal move.

Approach movement. Rapid probe move (G00) to the approach point located in front of the side to be probed at a "B" distance from it.

Probing. Probing movement at the indicated feedrate (F) until the probe signal is received. The maximum probing distance is 2B. If the CNC does not receive the probe signal before reaching moving this probing distance, it stops the axes and displays the relevant error message.

Withdrawal. Movement of the probe in rapid (G00) from the point where it probed to the approach point

3. Withdrawal.

Rapid tool movement (G00) from the approach point to the cycle calling point.

The withdrawal movement is made in two stages. It first moves along the X axis and then along the Z axis.

Actions after finishing the calibration cycle

Updating the tool offset data

Once the cycle is over, the CNC updates in the tool offset table, the data of the offset currently selected ("X", "Z" and "Y" values) and resets the "I", "K" and "J" values to 0.

Arithmetic parameters modified by the cycle

Once the cycle is over, the CNC will return the detected error in the following general arithmetic parameters.

- P298 Error detected on the X axis. Difference between the real tool length and the value assigned to the too offset.
- P299 Error detected on the Z axis. Difference between the real tool length and the value assigned to the too offset.
- P297 Error detected on the Y axis. Difference between the real tool length and the value assigned to the too offset.



CNC 8055
CNC 8055i

.T. MODEL
(SOFT V16.1x)

Actions after finishing the tool wear measuring cycle

When using tool live monitoring

In this case, it compares the X, Z and Y lengths with the theoretical values in the table. If the maximum allowed is exceeded, it issues a "tool rejected" message and acts as follows:

- C0 It interrupts the execution for the user to select another tool.
- C1 The cycle replaces the tool with another one of the same family.
It sets the "rejected tool" indicator (Status = R)
It activates the general logic output PRTREJEC (M5564).

To activate the rejected tool, either because it has been replaced with another one or not, the CNC offers the following options:

1. Go into the tool table in ISO mode and delete the real life of that tool.
2. Go into the tool table in ISO mode and write the desired value for the real life of that tool.

In this case, to activate the tool the real life value must be smaller than the nominal life value. Otherwise, the tool will be shown as expired (status = E).

If tool life monitoring is not available or the measuring difference does not exceed the maximum allowed

In this case, it updates global arithmetic parameters P298, P299, P297 as well as the length wear values of the tool offset selected in the tool offset table.

- P298 "Measured X length" - "Theoretical X length".
- P299 "Measured Z length" - "Theoretical Z length".
- P297 "Measured Y length" - "Theoretical Y length".
- X Theoretical X length It maintains the previous value.
- I "Measured X length" - "Theoretical X length". New wear value.
- Z Theoretical Z length. It maintains the previous value.
- K "Measured Z length" - "Theoretical Z length". New wear value.
- Y Theoretical Y length. It maintains the previous value.
- J "Measured Y length" - "Theoretical Y length". New wear value.

10.

PROBING
PROBE 1. Tool calibration canned cycle

FAGOR 

CNC 8055
CNC 8055i

·T· MODEL
(SOFT V16.1X)

10.4 PROBE 2. Probe calibration canned cycle

It may be used to calibrate the sides of the table-top probe, installed in a fixed position of the table and with its sides parallel to the X and Z axes. This probe will be the one used in the tool calibration canned cycle.

The probe position must be given in absolute coordinates referred to machine reference zero using the general machine parameters:

- PRBXMIN Probe's minimum X coordinate.
- PRBXMAX Probe's maximum X coordinate.
- PRBZMIN Probe's minimum Z coordinate.
- PRBZMAX Probe's maximum Z coordinate.

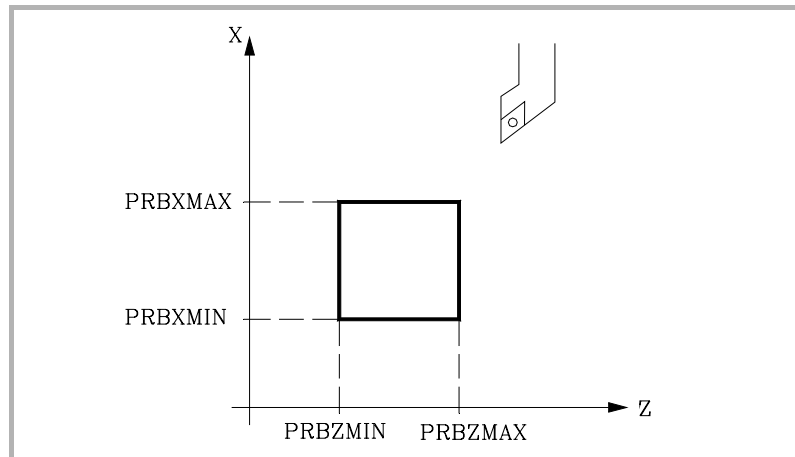

To execute the cycle, a master tool of known dimensions will be used with its relevant values previously entered in the selected offset. Since the probe needs to be calibrated along the X and Z axes, the location code (F) of the selected master tool must be F1, F3, F5 or F7.

Programming format

The programming format for this cycle is:

```
(PROBE 2, B, F, X, U, Z, W)
```

B5.5 Safety distance

It defines the safety distance and it must be programmed with a positive value higher than 0 (zero). Its value is given in radius.

F5.5 Probing feedrate

It sets the probing feedrate. It must be programmed in mm/minute or inches/minute.

X, U, Z, W Probe position

They are optional parameters that usually need not be defined. In certain machines, due to lack of repeatability in the mechanical positioning of the probe, the probe must be calibrated again before each calibration.

Instead of having to set again machine parameters PRBXMIN, PRBXMAX, PRBZMAX and PRBZMIN every time the probe is calibrated, those coordinates may be specified in parameters X, U, Y, V, Z and W respectively.

The CNC does not modify the machine parameters. The CNC considers the coordinates indicated in X, U, Z, W only during this calibration. If any of the X, U, Z, W fields is left out, the CNC takes the value assigned to the corresponding machine parameter.

10.

PROBING
PROBE 2. Probe calibration canned cycle



CNC 8055
CNC 8055i

.T- MODEL
(SOFT V16.1X)

10.4.1 Basic operation

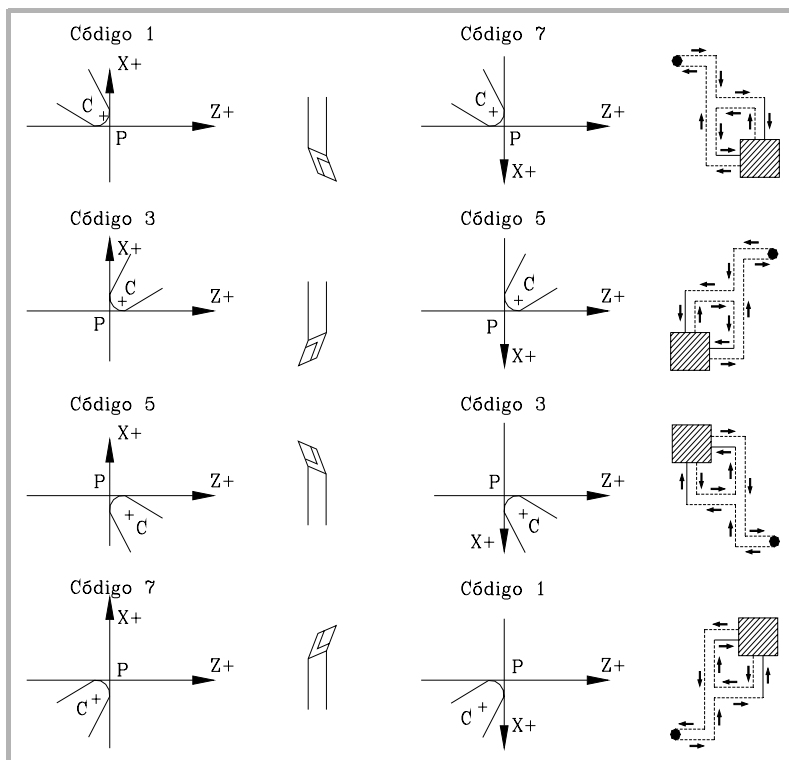

1. Approach movement.

Rapid tool movement (G00) from the cycle calling point to the approach point. This point is located in front of the corresponding probe corner, at a safety distance (B) from both sides.

The approach movement is made in two stages. It first moves along the Z axis and then along the X axis.

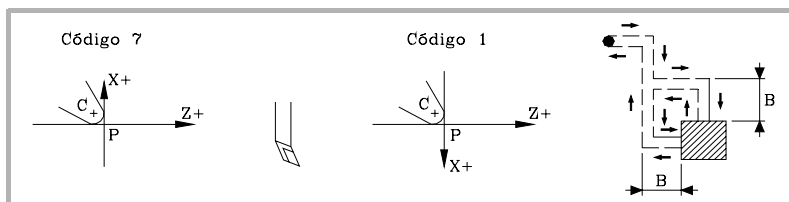

2. Probing.

The sides of the probe used in this probing move as well as the path traveled by the tool depend on the location code assigned to the selected tool.

2 probing moves are carried out in this stage. Each probing move will consist of an approach move, a probing move per se and a withdrawal move.

Approach movement. Rapid probe move (G00) to the approach point located in front of the side to be probed at a "B" distance from it.

Probing. Probing movement at the indicated feedrate (F) until the probe signal is received. The maximum probing distance is 2B. If the CNC does not receive the probe signal before reaching moving this probing distance, it stops the axes and displays the relevant error message.

Withdrawal. Movement of the probe in rapid (G00) from the point where it probed to the approach point

10.

PROBING
PROBE 2. Probe calibration canned cycle



CNC 8055
CNC 8055i

·T· MODEL
(SOFT V16.1x)

10.

PROBING
PROBE 2. Probe calibration canned cycle

3. Withdrawal.

Rapid tool movement (G00) from the approach point to the cycle calling point.

The withdrawal movement is made in two stages. It first moves along the X axis and then along the Z axis.

Arithmetic parameters modified by the cycle

Once the cycle is over, the CNC will return the measured values in the following general arithmetic parameters.

P298 Real X coordinate of the measured side. This value is given in absolute coordinates and in radius.

P299 Real Z coordinate of the measured side. This value is given in absolute coordinates.

Define the probe position

Once the values of parameters P298 and P297 and the probe dimensions are known, the user must calculate the coordinates of the other two sides and update the general machine parameters:

- PRBXMIN Probe's minimum X coordinate.
- PRBXMAX Probe's maximum X coordinate.
- PRBZMIN Probe's minimum Z coordinate.
- PRBZMAX Probe's maximum Z coordinate.

Example:

If the tool used has a location code F3 and the probe is square with 40 mm sides, the values to be assigned to these general machine parameters will be:

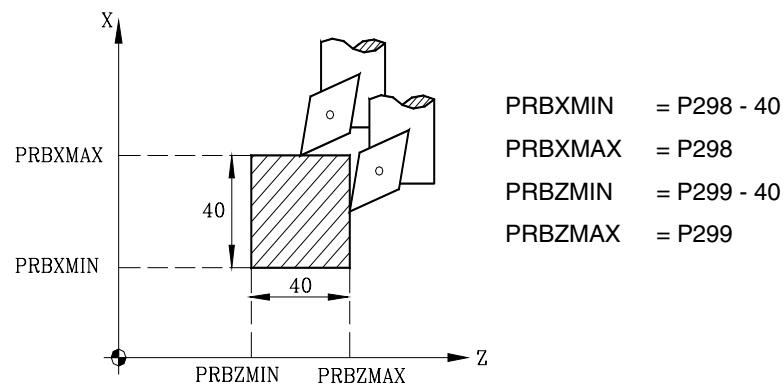

CNC 8055
CNC 8055i

.T- MODEL
(SOFT V16.1x)

10.5 PROBE 3. Canned cycle for part measuring and tool correction on the X axis

A probe mounted in the tool holding spindle must be used, it must be previously calibrated with the tool calibration canned cycle (PROBE 1).

This cycle, besides measuring the part along the X axis allows correcting the offset value of the tool used to machine that surface. This correction will be used only when the measurement error exceeds a programmed value.

Programming format

The programming format for this cycle is:

(PROBE 3, X, Z, B, F, L, D)

X±5.5 **Theoretical coordinate, along the X axis, of the point over which it is required to measure.**

This value is given in the active units, radius or diameter.

Z±5.5 **Theoretical coordinate, along the Z axis, of the point over which it is required to measure.**

B5.5 **Safety distance**

It defines the safety distance and it must be programmed with a positive value higher than 0 (zero). Its value is given in radius.

F5.5 **Probing feedrate**

It sets the probing feedrate. It must be programmed in mm/minute or inches/minute.

L5.5 **Error tolerance**

Defines the tolerance that will be applied to the error measured. It will be programmed with an absolute value and the tool offset will be corrected only when the error exceeds this value.

If this is not programmed, the canned cycle will take the value of 0.

D4 **Tool offset**

Defines the number of the tool offset to be corrected, once the measurement cycle is completed. If this is not programmed or is programmed with a value of 0, the CNC will understand that it is not required to make this correction.

10.

PROBING
PROBE 3. Canned cycle for part measuring and tool correction on the X axis



CNC 8055
CNC 8055i

·T· MODEL
(SOFT V16.1X)

10.5.1 Basic operation

10.

PROBING
PROBE 3. Canned cycle for part measuring and tool correction on the X axis

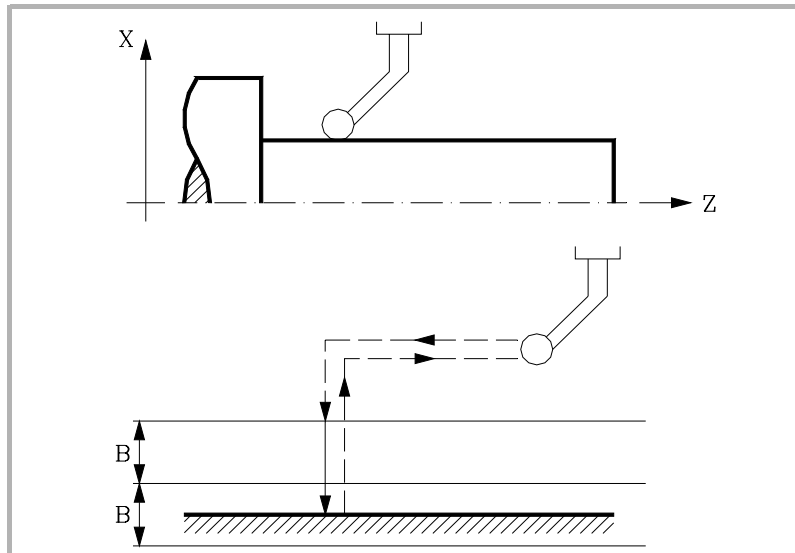

1. Approach movement.

Movement of the probe in rapid (G00) from the point where the cycle is called to the approach point. This point is located in front of the corresponding probe corner, at a safety distance (B) from both sides.

The approach movement is made in two stages. It first moves along the Z axis and then along the X axis.

2. Probing.

Probing movement along the X axis at the indicated feedrate (F) until the probe signal is received. The maximum probing distance is 2B. If the CNC does not receive the probe signal before reaching moving this probing distance, it stops the axes and displays the relevant error message.

Once probing has been made, the CNC will assume as their theoretical position the real position of the axes when the probe signal is received .

3. Withdrawal.

Rapid probe movement (G00) from the approach point to the cycle calling point.

The withdrawal movement is made in two stages. It first moves along the X axis and then along the Z axis. The X axis moves to the coordinate of the cycle calling point on that axis.

Updating the tool offset data

If a tool offset number (D) was defined, the CNC will modify the "I" value of that offset as long as the measurement error is equal to or greater than the tolerance (L).

Arithmetic parameters modified by the cycle

Once the cycle has ended, the CNC returns the values obtained in the measurement to the following general arithmetic parameters.

- | | |
|------|---|
| P298 | Real surface coordinate. This value is given in the active units, radius or diameter. |
| P299 | Error detected. Difference between the real coordinate of the surface and the theoretical programmed coordinate. This value is given in radius. |



CNC 8055
CNC 8055i

.T- MODEL
(SOFT V16.1x)

10.6 PROBE 4. Canned cycle for part measuring and tool correction on the Z axis

A probe mounted in the tool holding spindle must be used, it must be previously calibrated with the tool calibration canned cycle (PROBE 1).

This cycle, besides measuring the part along the Z axis allows correcting the offset value of the tool used to machine that surface. This correction will be used only when the measurement error exceeds a programmed value.

Programming format

The programming format for this cycle is:

(PROBE 4, X, Z, B, F, L, D)

X±5.5 **Theoretical coordinate, along the X axis, of the point over which it is required to measure.**

This value is given in the active units, radius or diameter.

Z±5.5 **Theoretical coordinate, along the Z axis, of the point over which it is required to measure.**

B5.5 **Safety distance**

It defines the safety distance and it must be programmed with a positive value higher than 0 (zero). Its value is given in radius.

F5.5 **Probing feedrate**

It sets the probing feedrate. It must be programmed in mm/minute or inches/minute.

L5.5 **Error tolerance**

Defines the tolerance that will be applied to the error measured. It will be programmed with an absolute value and the tool offset will be corrected only when the error exceeds this value.

If this is not programmed, the canned cycle will take the value of 0.

D4 **Tool offset**

Defines the number of the tool offset to be corrected, once the measurement cycle is completed. If this is not programmed or is programmed with a value of 0, the CNC will understand that it is not required to make this correction.

10.

PROBING
PROBE 4. Canned cycle for part measuring and tool correction on the Z axis



CNC 8055
CNC 8055i

·T· MODEL
(SOFT V16.1X)

10.6.1 Basic operation

10.

PROBING

PROBE 4: Canned cycle for part measuring and tool correction on the Z axis

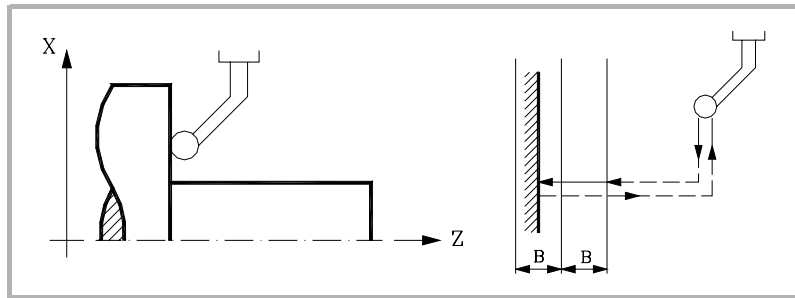

1. Approach movement.

Movement of the probe in rapid (G00) from the point where the cycle is called to the approach point. This point is located in front of the corresponding probe corner, at a safety distance (B) from both sides.

The approach movement is made in two stages. It first moves along the X axis and then along the Z axis.

2. Probing.

Probing movement along the Z axis at the indicated feedrate (F) until the probe signal is received. The maximum probing distance is 2B. If the CNC does not receive the probe signal before reaching moving this probing distance, it stops the axes and displays the relevant error message.

Once probing has been made, the CNC will assume as their theoretical position the real position of the axes when the probe signal is received .

3. Withdrawal.

Rapid probe movement (G00) from the approach point to the cycle calling point.

The withdrawal movement is made in two stages. It first moves along the Z axis and then along the X axis. The Z axis moves to the coordinate of the cycle calling point on that axis.

Updating the tool offset data

If a tool offset number (D) was defined, the CNC will modify the "K" value of that offset as long as the measurement error is equal to or greater than the tolerance (L).

Arithmetic parameters modified by the cycle

Once the cycle has ended, the CNC returns the values obtained in the measurement to the following general arithmetic parameters.

P298 Real surface coordinate.

P299 Error detected. Difference between the real coordinate of the surface and the theoretical programmed coordinate.



CNC 8055
CNC 8055i

.T- MODEL
(SOFT V16.1x)

11.1 Lexical description

All the words that make up the high-level language of the numerical control must be written in capital letters except for associated texts which may be written in upper and lower case letters.

The following elements are available for high-level programming:

- Reserved words.
- Numerical constants.
- Symbols.

Reserved words

Reserved words are those that the CNC uses in high-level programming for naming system variables, operators, control instructions, etc.

All the letters of the alphabet A-Z are also reserved words, as they can make up a high-level language word when used alone.

Numerical constants

Blocks programmed in high-level language admit numbers in decimal format and in hexadecimal format.

- The numbers in decimal format must not exceed the ± 6.5 format (6 digits to the left of the decimal point and 5 decimals).
- The numbers in hexadecimal format must be preceded by the \$ symbol and they must not have more than 8 digits.

A constant higher than the format ± 6.5 must be assigned to a variable by means of arithmetic parameters by means of arithmetic expressions or by means of constants in hexadecimal format.

To assign the value 100000000 to the variable "TIMER", It can be done in one of the following ways:

```
(TIMER = $5F5E100)
(TIMER = 10000 * 10000)
(P100 = 10000 * 10000)
(TIMER = P100)
```

If the CNC operates in the metric system (millimeters), the resolution is a tenth of a micron and the figures will be programmed in the ± 5.4 format (positive or negative with 5 digits to the left of the decimal point and 4 decimals).

If the CNC operates in inches, the resolution is a hundred-thousandths of an inch (ten millionths of an inch) and the figures will be programmed in the ± 4.5 format (positive or negative with 4 digits to the left of the decimal point and 5 decimals).

For the convenience of the programmer, this control always allows the format ± 5.5 (positive or negative, with 5 integers and 5 decimals), adjusting each number appropriately to the working units every time they are used.

Symbols

The symbols used in high-level language are:

() " = + - * / ,

11.

HIGH-LEVEL LANGUAGE PROGRAMMING
Lexical description



CNC 8055
CNC 8055i

.T- MODEL
(SOFT V16.1X)

11.2 Variables

The CNC has a number of internal variables that may be accessed from the user program, from the PLC program or via DNC. Depending on how they are used, these variables may be read-only or read-write.

These variables may be accessed from the user program using high-level commands. Each one of these variables is referred to by its mnemonic that must be written in upper-case (capital) letters.

- Mnemonics ending in (X-C) indicate a set of 9 elements formed by the corresponding root followed by X, Y, Z, U, V, W, A, B and C.

```
ORG(X-C) -> ORGX   ORGY   ORGZ
              ORGU   ORGV   ORGW
              ORGA   ORGB   ORGC
```

- Mnemonics ending in n indicate that the variables are grouped in tables. To access an element of any of these tables, indicate the field of the desired table using the relevant mnemonic followed by the desired element.

```
TORn ->   TOR1   TOR3   TOR11
```

The variables and block preparation

The variables that access the real values of the CNC interrupt block preparation. The CNC waits for that command to be executed before resuming block preparation. Thus, precaution must be taken when using this type of variable, because if they are inserted between machining blocks that are working with compensation, undesired profiles may be obtained.

Example: Reading a variable that interrupts block preparation.

The following program blocks are performed in a section with G41 compensation.

```
...
N10 X80 Z50
N15 (P100 = POSX); Assigns the value of the real coordinate in X to parameter P100
N20 X50 Z50
N30 X50 Z80
...
```

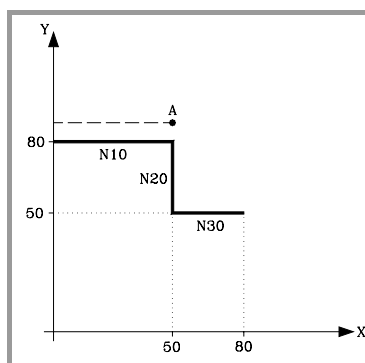

Block N15 interrupts block preparation and the execution of block N10 will finish at point A.

Once the execution of block N15 has ended, the CNC will resume block preparation from block N20 on.

11.

11.

HIGH-LEVEL LANGUAGE PROGRAMMING Variables

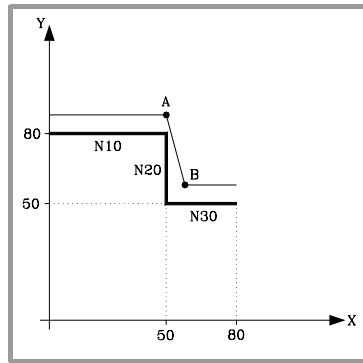

As the next point corresponding to the compensated path is point "B", the CNC will move the tool to this point, executing path "A-B".

As can be observed, the resulting path is not the desired one, and therefore it is recommended to avoid the use of this type of variable in sections having tool compensation active.



CNC 8055
CNC 8055i

.T- MODEL
(SOFT V16.1X)

11.2.1 General purpose parameters or variables

General purpose variables are referred to with the letter "P" followed by an integer number. The CNC has four types of general purpose variables.

Parameter type	Range
Local parameters	P0-P25
Global parameters	P100-P299
User parameters	P1000-P1255
OEM (manufacturer's) parameters	P2000 - P2255

Blocks programmed in ISO code allow associating parameters to the G F S T D M fields and coordinates of the axes. The block label number must be defined with a numeric value. If parameters are used in blocks programmed in high-level language, they can be programmed within any expression.

Programmers may use general purpose variables when editing their own programs. Later on, during execution, the CNC will replace these variables with the values assigned to them at the time.

When programming...	When executing...
GP0 XP1 Z100	G1 X-12.5 Z100
(IF (P100 * P101 EQ P102) GOTO N100)	(IF (2 * 5 EQ 12) GOTO N100)

Using these general purpose variables will depend on the type of block in which they are programmed and the channel of execution. Programs that are executed in the user channel may contain any global, OEM or user parameter, but may not use local parameters.

Types of arithmetic parameters

Local parameters

Local parameters can only be accessed from the program or subroutine where they have been programmed. There are seven groups of parameters.

Local parameters used in high-level language may be defined either using the above format or by using the letter A-Z, except for Ñ, so that A is equal to P0 and Z to P25.

The following example shows these two methods of definition:

```
( IF ((P0+P1) * P2/P3 EQ P4 ) GOTO N100 )
( IF ((A+B) * C/D EQ E ) GOTO N100 )
```

When using a parameter name (letter) for assigning a value to it (A instead of P0, for example), if the arithmetic expression is a constant, the instruction can be abbreviated as follows:

```
( P0=13.7 ) ==> ( A=13.7 ) ==> ( A13.7 )
```

Be careful when using parenthesis since M30 is not the same as (M30). The CNC interprets (M30) as a high level instruction meaning (P12 = 30) and not the execution of the miscellaneous M30 function.

Global parameters

Global parameters can be accessed from any program and subroutine called from a program.

Global parameters may be used by the user, by the OEM or by the CNC cycles.

User parameters

These parameters are an expansion of the global parameters but they are not used by the CNC cycles.

11.



CNC 8055
CNC 8055i

.T- MODEL
(SOFT V16.1x)

11.**OEM (manufacturer's) parameters**

OEM parameters and subroutines with OEM parameters can only be used in OEM programs; those defined with the [O] attribute. Modifying one of these parameters in the tables requires an OEM password.

Using arithmetic parameters by the cycles

Multiple machining cycles (G60 through G65) and the machining canned cycles (G69, G81 to G89) use the sixth nesting level of local parameters when they are active.

Machining canned cycles use the global parameter P299 for internal calculations and probing canned cycles use global parameters P294 to P299.

Updating arithmetic parameter tables

The CNC will update the parameter table after processing the operations indicated in the block that is in preparation. This operation is always done before executing the block and for this reason, the values shown in the table do not necessarily have to correspond to the block being executed.

If the execution mode is abandoned after interrupting the execution of the program, the CNC will update the parameter tables with values corresponding to the block that was being executed.

When accessing the local parameter and global parameter table, the value assigned to each parameter may be expressed in decimal notation (4127.423) or in scientific notation (0.23476 E-3).

Arithmetic parameters in the subroutines

This CNC has high level instructions that allow the definition and use of subroutines that can be called from the main program, or from another subroutine, it also being possible to call a second subroutine, from the second to a third, etc. The CNC limits these calls to a maximum of 15 nesting levels.

Up to 26 (P0-P25) local parameters may be assigned to a subroutine. These parameters, that will be unknown for blocks outside the subroutine, may be referred to by the blocks that make up the subroutine.

Local parameters may be assigned to more than one subroutine up to 6 parameter nesting levels within the 15 subroutine nesting levels.



CNC 8055
CNC 8055i

.T- MODEL
(SOFT V16.1x)

11.2.2 Variables associated with tools

These variables are associated with the tool offset table, tool table and tool magazine table, so the values which are assigned to or read from these fields will comply with the formats established for these tables.

Tool Offset table

The radius (R), length (L) and wear offset (I, K) values of the tool are given in the active units.

If G70, in inches (within ± 3937.00787).

If G71, in millimeters (within ± 99999.9999).

If rotary axis in degrees (within ± 99999.9999).

The location (tool shape) code (F) will be an integer between 0 and 9.

Tool table

The tool offset number is an integer between 0 and 255. The maximum number of tool offsets is limited by g.m.p. NTOFFSET.

The family code is a number between 0 and 255.

0 to 199 if it is a normal tool.

200 to 255 if it is a special tool.

The nominal life is given either in minutes or in operations (0..65535).

The real (actual) life is given either in hundredths of a minute (0..999999) or in operations (0..999999).

The cutter angle is given in ten-thousandths of a degree (0..359999).

The cutter width is given in the active units.

If G70, in inches (within ± 3937.00787).

If G71, in millimeters (within ± 99999.9999).

If rotary axis in degrees (within ± 99999.9999).

The cutting angle is given in ten-thousandths of a degree (0..359999).

Tool magazine table

Each magazine position is represented as follows:

1..255	Tool number.
0	The magazine position is empty.
-1	The magazine position has been canceled.

The tool position in the magazine is represented as follows:

1..255	Position number.
0	The tool is in the spindle.
-1	Tool not found.
-2	The tool is in the change position.

Read-only variables

TOOL	Returns the number of the active tool.
	(P100=TOOL) Assigns the number of the active tool to parameter P100.
TOD	Returns the number of the active tool offset.
NXTOOL	Returns the next tool number, which is selected but is awaiting the execution of M06 to be active.
NXTOD	Returns the number of the tool offset corresponding to the next tool, which is selected but is awaiting the execution of M06 to be active.
TMZPn	Returns the position occupied in the tool magazine by the indicated tool (n).

Read-and-write variables

TOXn	This variable allows reading or modifying the length value along the X axis assigned to the indicated tool offset (n).
	(P110=TOX3) Assigns the X value of tool offset ·3· to Parameter P110. (TOX3=P111) Assigns the value of parameter P111 to the X value of tool offset ·3·.
TOZn	This variable allows reading or modifying the length value along the Z axis assigned to the indicated tool offset (n).
TOFn	This variable allows reading or modifying the location code (F) of the indicated tool offset (n).
TORn	This variable allows reading or modifying the radius R value of the indicated tool offset (n).
TOIn	This variable allows reading or modifying the length wear value (I) along the X axis of the indicated tool offset (n).
TOKn	This variable allows reading or modifying the length wear value (K) along the Z axis of the indicated tool offset (n).
NOSEAn	This variable allows reading or modifying the cutter angle assigned to the indicated tool (n) in the tool table.
NOSEWn	This variable allows reading or modifying the cutter width assigned to the indicated tool (n) in the tool table.
CUTAn	This variable allows reading or modifying the cutting angle assigned to the indicated tool (n) in the tool table.
TLFDn	This variable allows the tool offset number of the indicated tool (n) to be read or modified in the tool table.
TLFFn	This variable allows the family code of the indicated tool (n) to be read or modified in the tool table.
TLFNn	This variable allows the value assigned as the nominal life of the indicated tool (n) to be read or modified in the tool table.
TLFRn	This variable allows the value corresponding to the real life of the indicated tool (n) to be read or modified in the tool table.

11.

HIGH-LEVEL LANGUAGE PROGRAMMING Variables



CNC 8055
CNC 8055i

·T· MODEL
(SOFT V16.1X)

TMZTn This variable allows the contents of the indicated position (n) to be read or modified in the tool magazine table.

HTOR The HTOR variable indicates the tool radius being used by the CNC to do the calculations.

Being a variable that can be read and written by the CNC and read-only from the PLC and DNC, its value may be different from the one assigned in the table (TOR).

On power-up, after a T function, after a RESET or after an M30 function, it assumes the value of the table (TOR).

Application example

To machine a profile with a residual stock of 0.5 mm running 0.1mm-passes with a tool whose radius is 10 mm.

Assign to the tool radius the value of:

10.5 mm in the table and execute the profile.

10,4 mm in the table and execute the profile.

10,3 mm in the table and execute the profile.

10,2 mm in the table and execute the profile.

10,1 mm in the table and execute the profile.

10,0 mm in the table and execute the profile.

However, if while machining, the program is interrupted or a reset occurs, the table assumes the radius value assigned in that instant (e.g.: 10.2 mm). Its value has changed.

To avoid this, instead of modifying the tool radius in the (TOR) table, use the variable (HTOR) to change the tool radius value used by the CNC to calculate.

Now, if the program is interrupted, the tool radius value initially assigned in the (TOR) table will be correct because it has not changed.

11.

11.2.3 Variables associated with zero offsets

These variables are associated with the zero offsets and may correspond to the table values or to those currently preset either by means of function G92 or manually in the JOG mode.

The possible zero offsets in addition to the additive offset indicated by the PLC, are G54, G55, G56, G57, G58 and G59.

The values for each axis are given in the active units:

If G70, in inches (within ±3937.00787).

If G71, in millimeters (within ±99999.9999).

If rotary axis in degrees (within ±99999.9999).

Although there are variables which refer to each axis, the CNC only allows those referring to the axes selected at the CNC. Thus, if the CNC controls axes X, Y, Z, U and B, it only allows the variables ORGX, ORGY, ORGZ, ORGU and ORGB in the case of ORG(X-C).

Read-only variables

ORG(X-C)

Returns the value of the active zero offset in the selected axis. The value of the additive offset indicated by the PLC or by the additive handwheel is not included in this value.

(P100=ORGX)

It assigns to P100 the X value of the part zero active for the X axis. This value could have been set either manually, by means of function G92 or by the variable "ORG(X-C)n".

PORGF

Returns the abscissa value of the polar coordinate origin with respect to the Cartesian origin.

This value is given in radius or diameter depending on the setting of axis machine parameter "DFORMAT".

PORGS

Returns the ordinate value of the polar coordinate origin with respect to the Cartesian origin.

This value is given in radius or diameter depending on the setting of axis machine parameter "DFORMAT".

ADIOF(X-C)

It returns the value of the zero offset generated by the additive handwheel in the selected axis.

Read-and-write variables

ORG(X-C)n

This variable allows the value of the selected axis to be read or modified in the table corresponding to the indicated zero offset (n).

(P110=ORGX 55)

Loads parameter P100 with the X value of G55 in the zero offset table.

(ORGZ 54=P111)

It assigns parameter P111 to the Z axis in the table for the G54 offset.

11.



CNC 8055
CNC 8055i

.T- MODEL
(SOFT V16.1X)

PLCOF(X-C)

This variable allows the value of the selected axis to be read or modified in the table of additive offsets indicated by the PLC.

Accessing any of the PLCOF(X-C) variables interrupts block preparation and the CNC waits for that command to be executed before resuming block preparation.

11.**HIGH-LEVEL LANGUAGE PROGRAMMING**
Variables**FAGOR** **CNC 8055**
CNC 8055i·T· MODEL
(SOFT V16.1X)

11.2.4 Variables associated with machine parameters

These variables associated with machine parameters are read-only variables. These variables may be read and written when executed inside an OEM program or subroutine.

Refer to the installation and start-up manual to know the format of the values returned. The values of 1/0 correspond to the parameters that are set as YES/NO, +/- or ON/OFF.

The coordinate and feedrate values are given in the active units:

If G70, in inches (within ± 3937.00787).

If G71, in millimeters (within ± 99999.9999).

If rotary axis in degrees (within ± 99999.9999).

Modify the machine parameters from an OEM program or subroutine.

These variables may be read and written when executed inside an OEM program or subroutine. In this case, these variables can be used to modify the value of certain machine parameters. Refer to the installation manual for the list of machine parameters that may be modified.

In order to be able to modify these parameters via PLC, an OEM subroutine containing the relevant variables must be executed using the CNCEX command.

Read-only variables

MPGn

Returns the value assigned to general machine parameter (n).

(P110=MPG8)

It assigns the value of the general machine parameter P8 "INCHES" to parameter P110, if millimeters P110=0 and if inches P110=1.

MP(X-C)n

Returns the value assigned to the machine parameter (n) of the indicated axis (X-C).

(P110=MPY 1)

Assigns the value of Y axis machine parameter P1 "DFORMAT" to parameter P110.

MPSn

Returns the value assigned to the indicated machine parameter (n) of the main spindle.

MPSSn

Returns the value assigned to the indicated machine parameter (n) of the second spindle.

MPASn

Returns the value of the indicated machine parameter (n) of the auxiliary spindle.

MPLCn

Returns the value assigned to the indicated machine parameter (n) of the PLC.

11.

HIGH-LEVEL LANGUAGE PROGRAMMING
Variables



CNC 8055
CNC 8055i

.T- MODEL
(SOFT V16.1x)

11.2.5 Variables associated with work zones

Variables associated with work zones are read-only variables.

The values of the limits are given in the active units:

If G70, in inches (within ±3937.00787).

If G71, in millimeters (within ±99999.9999).

If rotary axis in degrees (within ±99999.9999).

The status of the work zones are defined according to the following code:

0 = Disabled.

1 = Enabled as no-entry zone.

2 = Enabled as no-exit zone.

Read-only variables

FZONE	It returns the status of work zone 1.
FZLO(X-C)	Lower limit of zone 1 along the selected axis (X-C).
FZUP(X-C)	Upper limit of zone 1 along the selected axis (X-C).

```
(P100=FZONE) ; It assigns to parameter P100 the status of work zone 1.
(P101=FZLOX) ; It assigns the lower limit of zone 1 to parameter P101.
(P102=FZUPZ) ; It assigns the upper limit of zone 1 to parameter P102.
```

SZONE	Status of work zone 2.
SZLO(X-C)	Lower limit of zone 2 along the selected axis (X-C).
SZUP(X-C)	Upper limit of zone 2 along the selected axis (X-C).
TZONE	Status of work zone 3.
TZLO(X-C)	Lower limit of zone 3 along the selected axis (X-C).
TZUP(X-C)	Upper limit of zone 3 along the selected axis (X-C).
FOZONE	Status of work zone 4.
FOZLO(X-C)	Lower limit of zone 4 along the selected axis (X-C).
FOZUP(X-C)	Upper limit of zone 4 along the selected axis (X-C).
FIZONE	Status of work zone 5.
FIZLO(X-C)	Lower limit of zone 5 along the selected axis (X-C).
FIZUP(X-C)	Upper limit of zone 5 along the selected axis (X-C).

11.

11.2.6 Variables associated with feedrates

Read-only variables associated with the real (actual) feedrate

FREAL It returns the CNC's real feedrate. In mm/minute or inches/minute.

(P100=FREAL)

It assigns the real feedrate value of the CNC to parameter P100.

FREAL(X-C) It returns the actual (real) CNC feedrate of the selected axis.

FTEO(X-C) It returns the theoretical CNC feedrate of the selected axis.

Read-only variables associated with function G94

FEED It returns the feedrate selected at the CNC by function G94. In mm/minute or inches/minute.

This feedrate may be indicated by program, by PLC or by DNC; the CNC selects one of them, the one indicated by DNC has the highest priority and the one indicated by program has the lowest priority.

DNCF It returns the feedrate, in mm/minute or inches/minute selected by DNC. If it has a value of 0 it means that it is not selected.

PLCF It returns the feedrate, in mm/minute or inches/minute selected by PLC. If it has a value of 0 it means that it is not selected.

PRGF It returns the feedrate, in mm/minute or inches/minute selected by program.

Read-only variables associated with function G95

FPREV It returns the feedrate selected at the CNC by function G95. In mm/turn or inches/turn.

This feedrate may be indicated by program, by PLC or by DNC; the CNC selects one of them, the one indicated by DNC has the highest priority and the one indicated by program has the lowest priority.

DNCFPR It returns the feedrate, in mm/turn or inches/turn selected by DNC. If it has a value of 0 it means that it is not selected.

PLCFPR It returns the feedrate, in mm/turn or inches/turn selected by PLC. If it has a value of 0 it means that it is not selected.

PRGFPR It returns the feedrate, in mm/turn or inches/turn selected by program.

Read-only variables associated with function G32

PRGFIN It returns the feedrate selected by program, in 1/min.

Likewise, the CNC variable FEED, associated with G94, indicates the resulting feedrate in mm/min or inches/min.

11.

HIGH-LEVEL LANGUAGE PROGRAMMING
Variables



CNC 8055
CNC 8055i

.T- MODEL
(SOFT V16.1x)

Read-only variables associated with the override

FRO	It returns the feedrate override (%) currently selected at the CNC. It is given in integer values between 0 and "MAXFOVR" (maximum 255). This feedrate percentage may be indicated by program, by PLC, by DNC or by the front panel; the CNC selects one of them and the priority (from the highest to the lowest) is: by program, by DNC, by PLC and from the front panel switch.
DNCFRO	It returns the feedrate override % currently selected by the DNC. If it has a value of 0 it means that it is not selected.
PLCFRO	It returns the feedrate override % currently selected by the PLC. If it has a value of 0 it means that it is not selected.
CNCFRO	It returns the feedrate override % currently selected by the switch.
PLCCFR	It returns the feedrate percentage currently selected by the PLC's execution channel.

Read-write variables associated with the override

PRGFRO	This variable may be used to read or modify the feedrate override percentage currently selected by program. It is given in integer values between 0 and "MAXFOVR" (maximum 255). If it has a value of 0 it means that it is not selected.
---------------	---

```
( P110=PRGFRO )
```

It assigns to P110 the % of feedrate override selected by program.

```
( PRGFRO=P111 )
```

It sets the feedrate override % selected by program to the value of P111.

11.

HIGH-LEVEL LANGUAGE PROGRAMMING
Variables

FAGOR 

CNC 8055
CNC 8055i

·T· MODEL
(SOFT V16.1X)

11.2.7 Variables associated with coordinates

The coordinate values for each axis are given in the active units:

If G70, in inches (within ±3937.00787).

If G71, in millimeters (within ±99999.9999).

If rotary axis in degrees (within ±99999.9999).

11.

Read-only variables

Accessing any of the variables POS(X-C), TPOS(X-C), APOS(X-C), ATPOS(X-C) or FLWE(X-C) interrupts block preparation and the CNC waits for that command to be executed before resuming block preparation.

The coordinates provided by the variables PPOS(X-C), POS(X-C), TPOS(X-C), APOS(X-C) and ATPOS(X-C) are given in the active units system (radius or diameter). Check the DIAM variable to know the active units system.

PPOS(X-C)

Returns the programmed theoretical coordinate of the selected axis.

(P110=PPOSX)

It assigns to P100 the programmed theoretical position of the X axis.

POS(X-C)

It returns the real tool base position value referred to machine reference zero (home).

On limit-less rotary axes, this variable takes into account the value of the active zero offset. The values of the variable are between the active zero offset and ±360° (ORG* ± 360°).

If ORG* = 20° it displays between 20° and 380° / displays between -340° and 20°.

If ORG* = -60° it displays between -60° and 300° / displays between -420 and -60°

TPOS(X-C)

It returns the theoretical position value (real coordinate + following error) of the tool base referred to machine reference zero (home).

On limit-less rotary axes, this variable takes into account the value of the active zero offset. The values of the variable are between the active zero offset and ±360° (ORG* ± 360°).

If ORG* = 20° it displays between 20° and 380° / displays between -340° and 20°.

If ORG* = -60° it displays between -60° and 300° / displays between -420 and -60°

APOS(X-C)

It returns the real tool base position value, referred to part zero, of the selected axis.

ATPOS(X-C)

It returns the theoretical position value (real coordinate + following error) of the tool base referred to part zero.

FLWE(X-C)

It returns the following error of the selected axis.

DPLY(X-C)

It returns the position value (coordinate) shown on the screen for the selected axis.

DRPO(X-C)

It returns the position indicated by the Sercos drive of the selected axis (variable PV51 or PV53 of the drive).



CNC 8055
CNC 8055i

GPOS(X-C)n p Programmed coordinate for a particular axis in the indicated (n) block of the (p) program.

```
(P80=GPOSX N99 P100)
```

It assigns to parameter P88 the value of the coordinate programmed for the X axis in the block having the label N99 and located in program P100.

Only programs located in the CNC's RAM memory may be consulted.

If the defined program or block does not exist, it shows the relevant error message. If the indicated block does not contain the requested axis, it returns the value 100000.0000.

Read-and-write variables

DIST(X-C)

These variables may be used to read or modify the distance traveled by the selected axis. This value is accumulative and is very useful when it is required to perform an operation which depends on the distance traveled by the axes, their lubrication for example.

```
(P110=DISTX)
```

It assigns to P110 the distance traveled by the X axis

```
(DISTX=P111)
```

It presets the variable indicating the distance traveled by the Z axis with the value of arithmetic parameter P111.

Accessing any of the DIST(X-C) variables interrupts block preparation and the CNC waits for that command to be executed before resuming block preparation.

**LIMPL(X-C)
LIMMI(X-C)**

With these variables, it is possible to set a second travel limit for each axis: LIMPL for the upper limit and LIMMI for the lower one.

Since the second limits are activated or deactivated from the PLC, through general logic input ACTLIM2 (M5052), besides setting the limits, an auxiliary M code must be executed to let it know.

It is also recommended to execute function G4 after the change so the CNC executes the following blocks with the new limits.

The second travel limit will be taken into account if the first one has been set using axis machine parameters LIMIT+ (P5) and LIMIT- (P6).

11.

HIGH-LEVEL LANGUAGE PROGRAMMING
Variables



CNC 8055
CNC 8055i

·T· MODEL
(SOFT V16.1X)

11.2.8 Variables associated with electronic handwheels

11.

Read-only variables

HANPF
HANPS
HANPT
HANPFO

They return the pulses of the first (HANPF), second (HANPS), third (HANPT) or fourth (HANPFO) handwheel received since the CNC was turned on. It is irrelevant to have the handwheel connected to the feedback inputs or to the PLC inputs.

HANDSE

For handwheels with axis selector button, it indicates whether that button has been pressed or not. A value of ·0· means that it has not been pressed.

HANFCT

It returns the multiplying factor set by PLC for each handwheel.

It must be used when using several electronic handwheels or when using a single handwheel but different multiplying factors (x1, x10, x100) are to be applied to each axis.

C			B			A			W			V			U			Z			Y			X		
c	b	a	c	b	a	c	b	a	c	b	a	c	b	a	c	b	a	c	b	a	c	b	a	c	b	a

Once the switch has been turned to one of the handwheel positions, the CNC checks this variable and, depending on the values assigned to each axis bit (c, b, a) it applies the multiplying factor selected for each one of them.

c b a

- 0 0 0 The value indicated at the front panel or keyboard switch.
- 0 0 1 x1 factor
- 0 1 0 x10 factor
- 1 0 0 x100 factor

If there are more than one bit set to "1" for an axis, the least significant bit will be considered. Thus:

c b a

- 1 1 1 x1 factor
- 1 1 0 x10 factor



The screen always shows the value selected at the switch.

HBEVAR

It must be used when having a Fagor HBE handwheel.

It indicates whether the HBE handwheel is enabled or not, the axis to be jogged and the multiplying factor to be applied (x1, x10, x100).

		C			B			A			W			V			U			Z			Y			X		
*	^	c	b	a	c	b	a	c	b	a	c	b	a	c	b	a	c	b	a	c	b	a	c	b	a	c	b	a

(*) Indicates whether the HBE handwheel pulses will be taken into account or not in jog mode.

- 0 = They are ignored.
- 1 = They are taken into account.

(^) When the machine has a general handwheel and individual handwheels (associated with an axis), it indicates which handwheel has priority when both are turned at the same time.

- 0 = The individual handwheel has priority. The relevant axis ignores the pulses from the general handwheel, the rest of the axes don't.
- 1 = The general handwheel has priority. It ignores the pulses from the individual handwheel.



CNC 8055
CNC 8055i

·T· MODEL
(SOFT V16.1X)

(a, b, c) Indicate the axis to be moved and the selected multiplying factor.

c	b	a	
0	0	0	The value indicated at the front panel or keyboard switch.
0	0	1	x1 factor
0	1	0	x10 factor
1	0	0	x100 factor

If several axes are selected, the following order of priority is applied: X, Y, Z, U, V, W, A, B, C.

If there are more than one bit set to "1" for an axis, the least significant bit will be considered. Thus:

c	b	a	
1	1	1	x1 factor
1	1	0	x10 factor

The HBE handwheel has priority. That is, regardless of the mode selected at the CNC switch (continuous or incremental JOG, handwheel), HBEVAR is set to other than "0", the CNC goes into handwheel mode.

It shows the selected axis in reverse video and the multiplying factor selected by the PLC. When the HBEVAR variable is set to "0", it shows the mode selected by the switch again.

Read-and-write variables

MASLAN

It must be used when the path-handwheel or the path-jog is selected.

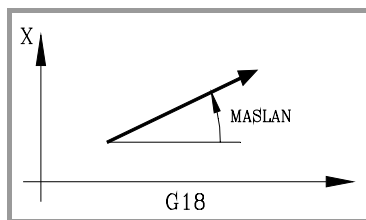

Indicates the angle of the linear path.

MASCFI MASCSE

They must be used when the path-handwheel or the path-jog is selected.

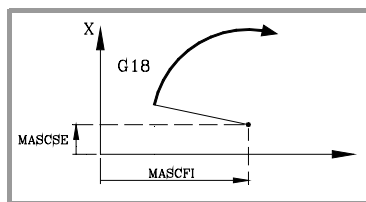

On circular paths (arcs), they indicate the center coordinates.

11.2.9 Variables associated with feedback

ASIN(X-C)	"A" signal of the CNC's sinusoidal feedback for the X-C axis.
BSIN(X-C)	"B" signal of the CNC's sinusoidal feedback for the X-C axis.
ASINS	"A" signal of the CNC's sinusoidal feedback for the spindle.
BSINS	"B" signal of the CNC's sinusoidal feedback for the spindle.
SASINS	"A" signal of the CNC sinusoidal feedback for the second spindle.
SBSINS	"B" signal of the CNC sinusoidal feedback for the second spindle.

11.

HIGH-LEVEL LANGUAGE PROGRAMMING
Variables



CNC 8055
CNC 8055i

.T- MODEL
(SOFT V16.1X)

11.2.10 Variables associated with the main spindle

In these variables associated with the spindle, their values are given in revolutions per minute and the main spindle override values are given in integers from 0 to 255.

Certain variables interrupt block preparation (it is indicated in each one) and the CNC waits for that command to be executed before resuming block preparation.

Read-only variables

SREAL	<p>Returns the real main spindle turning speed in revolutions per minute. It interrupts block preparation.</p> <div style="background-color: #ffffcc; padding: 5px; margin-top: 10px;"> <p>(P100=SREAL)</p> <p>It assigns to P100 the real turning speed of the main spindle.</p> </div>
FTEOS	<p>It returns the theoretical turning speed of the main spindle.</p>
SPEED	<p>Returns, in revolutions per minute, the main spindle speed selected at the CNC.</p> <p>This turning speed may be indicated by program, by PLC or by DNC; the CNC selects one of them, the one indicated by DNC has the highest priority and the one indicated by program has the lowest priority.</p>
DNCS	<p>Returns the turning speed in revolutions per minute, selected by DNC. If it has a value of 0 it means that it is not selected.</p>
PLCS	<p>Returns the turning speed in revolutions per minute selected by PLC. If it has a value of 0 it means that it is not selected.</p>
PRGS	<p>Returns the turning speed in revolutions per minute, selected by program.</p>
CSS	<p>It returns the constant surface speed selected at the CNC. Its value is given in the active units (ft/min or m/min).</p> <p>This constant surface speed may be indicated by program, by PLC or by DNC; the CNC selects one of them, the one indicated by DNC has the highest priority and the one indicated by program has the lowest priority.</p>
DNCCSS	<p>It returns the constant surface speed selected via DNC. Its value is given in m/min or ft/min and it is 0 it means that it is not currently selected.</p>
PLCCSS	<p>It returns the constant surface speed selected by PLC. Its value is given in m/min or ft/min.</p>
PRGCSS	<p>It returns the constant surface speed selected by program. Its value is given in m/min or ft/min.</p>
SSO	<p>It returns the turning speed override (%) of the main spindle currently selected at the CNC. It is given in integer values between 0 and "MAXFOVR" (maximum 255).</p> <p>This turning speed percentage of the main spindle may be indicated by program, by PLC, by DNC or by the front panel; the CNC selects one of them and the priority (from the highest to the lowest) is: by program, by DNC, by PLC and from the front panel.</p>
DNCSO	<p>It returns the turning speed override % of the main spindle currently selected via DNC. If it has a value of 0 it means that it is not selected.</p>
PLCSO	<p>It returns the turning speed override % of the main spindle currently selected by PLC. If it has a value of 0 it means that it is not selected.</p>
CNCSO	<p>It returns the turning speed override % of the main spindle currently selected from the front panel.</p>

11.



CNC 8055
CNC 8055i

.T- MODEL
(SOFT V16.1X)

11.

HIGH-LEVEL LANGUAGE PROGRAMMING Variables

SLIMIT	It returns the value set in rpm at the CNC for the turning speed limit of the main spindle. This limit may be indicated by program, by PLC or by DNC; the CNC selects one of them, the one indicated by DNC has the highest priority and the one indicated by program has the lowest priority.
DNCSL	It returns the speed limit of the main spindle in rpm currently selected via DNC. If it has a value of 0 it means that it is not selected.
PLCSL	It returns the speed limit of the main spindle in rpm currently selected by PLC. If it has a value of 0 it means that it is not selected.
PRGSL	It returns the speed limit of the main spindle in rpm currently selected by program.
MDISL	Maximum machining spindle speed. This variable is also updated (refreshed) when programming function G92 via MDI.
POSS	It returns the real position of the main spindle. Its value may be within $\pm 99999.9999^\circ$. It interrupts block preparation.
RPOSS	It returns the real position of the main spindle in 360° module. Its value may be between 0 and 360° . It interrupts block preparation.
TPOSS	It returns the theoretical position of the main spindle (real position + lag). Its value may be within $\pm 99999.9999^\circ$. It interrupts block preparation.
RTPOSS	It returns the theoretical position of the main spindle (real position + lag) in 360° module. Its value may be between 0 and 360° . It interrupts block preparation.
DRPOS	Position indicated by the Sercos drive of the main spindle.
PRGSP	Position programmed in M19 via program for the main spindle. This variable may be read from the CNC, from the PLC and from DNC.
FLWES	It returns the main spindle's following error in degrees (within ± 99999.9999). It interrupts block preparation.
SYNCER	It returns, in degrees (within ± 99999.9999), the following error of the second spindle with respect to the main spindle when they are synchronized in position.

Read-and-write variables

PRGSSO	This variable may be used to read or modify the speed override percentage of the main spindle currently selected by program. It is given in integer values between 0 and "MAXFOVR" (maximum 255). If it has a value of 0 it means that it is not selected.
---------------	--

(P110=PRGSSO)

It assigns to P110 the % of the main spindle speed selected by program.

(PRGSSO=P111)

It sets the value indicating the main spindle speed % selected by program to the value of arithmetic parameter P111.



CNC 8055
CNC 8055i

.T- MODEL
(SOFT V16.1x)

11.2.11 Variables associated with the second spindle

In these variables associated with the spindle, their values are given in revolutions per minute and the 2nd spindle override values are given in integers from 0 to 255.

Read-only variables

SSREAL	<p>Returns the real 2nd spindle turning speed in revolutions per minute.</p> <div style="background-color: #ffffcc; padding: 5px; margin: 5px 0;"> <p>(P100=SSREAL)</p> <p>It assigns to P100 the real turning speed of the second spindle.</p> </div> <p>If this variable is accessed, block preparation is interrupted and the CNC waits for this command to be executed to resume block preparation.</p>
SFTEOS	<p>It returns the theoretical turning speed of the second spindle.</p>
SSPEED	<p>Returns, in revolutions per minute, the 2nd spindle speed selected at the CNC.</p> <p>This turning speed may be indicated by program, by PLC or by DNC; the CNC selects one of them, the one indicated by DNC has the highest priority and the one indicated by program has the lowest priority.</p>
SDNCS	<p>Returns the turning speed in revolutions per minute, selected by DNC. If it has a value of 0 it means that it is not selected.</p>
SPLCS	<p>Returns the turning speed in revolutions per minute selected by PLC. If it has a value of 0 it means that it is not selected.</p>
SPRGS	<p>Returns the turning speed in revolutions per minute, selected by program.</p>
SCSS	<p>It returns the constant surface speed selected at the CNC. Its value is given in the active units (ft/min or m/min).</p> <p>This constant surface speed may be indicated by program, by PLC or by DNC; the CNC selects one of them, the one indicated by DNC has the highest priority and the one indicated by program has the lowest priority.</p>
SDNCCS	<p>It returns the constant surface speed selected via DNC. Its value is given in m/min or ft/min and it is 0 it means that it is not currently selected.</p>
SPLCCS	<p>It returns the constant surface speed selected by PLC. Its value is given in m/min or ft/min.</p>
SPRGCS	<p>It returns the constant surface speed selected by program. Its value is given in m/min or ft/min.</p>
SSSO	<p>It returns the turning speed override (%) of the second spindle currently selected at the CNC. It is given in integer values between 0 and "MAXFOVR" (maximum 255).</p> <p>This turning speed percentage of the second spindle may be indicated by program, by PLC, by DNC or by the front panel; the CNC selects one of them and the priority (from the highest to the lowest) is: by program, by DNC, by PLC and from the front panel.</p>
SDNCSO	<p>It returns the turning speed override % of the second spindle currently selected via DNC. If it has a value of 0 it means that it is not selected.</p>
SPLCSO	<p>It returns the turning speed override % of the second spindle currently selected by PLC. If it has a value of 0 it means that it is not selected.</p>

11.



CNC 8055
CNC 8055i

.T- MODEL
(SOFT V16.1X)

11.

HIGH-LEVEL LANGUAGE PROGRAMMING Variables

SCNCSO	It returns the turning speed override % of the second spindle currently selected from the front panel.
SSLIMI	It returns the value set in rpm at the CNC for the turning speed limit of the second spindle. This limit may be indicated by program, by PLC or by DNC; the CNC selects one of them, the one indicated by DNC has the highest priority and the one indicated by program has the lowest priority.
SDNCSL	It returns the speed limit of the second spindle in rpm currently selected via DNC. If it has a value of 0 it means that it is not selected.
SPLCSL	It returns the speed limit of the second spindle in rpm currently selected by PLC. If it has a value of 0 it means that it is not selected.
SPRGSL	It returns the speed limit of the second spindle in rpm currently selected by program.
SPOSS	It returns the real position of the second spindle. Its value may be within $\pm 99999.9999^\circ$.
SRPOSS	It returns the real position of the second spindle in 360° module. Its value will be given between 0 and 360° .
STPOSS	It returns the theoretical position of the second spindle (real position + lag). Its value may be within $\pm 99999.9999^\circ$.
SRTPOS	Returns the second spindle's theoretical position value (real coordinate+ following error) in a 360° module. Its value may be between 0 and 360° .
SDRPOS	Position indicated by the Sercos drive of the second spindle.
SPRGSP	Position programmed in M19 via program for the second spindle. This variable may be read from the CNC, from the PLC and from DNC.
SFLWES	It returns the second spindle's following error in degrees (within ± 99999.9999). When accessing one of these variables SPOSS, SRPOSS, STPOSS, SRTPOSS or SFLWES, block preparation is interrupted and the CNC waits for that command to be executed before resuming block preparation.

Read-and-write variables

SPRGSO	This variable may be used to read or modify the speed override percentage of the second spindle currently selected by program. It is given in integer values between 0 and "MAXFOVR" (maximum 255). If it has a value of 0 it means that it is not selected.
---------------	--

(P110=SPRGSO)

It assigns to P110 the % of the second spindle speed selected by program.

(SPRGSO=P111)

It sets the value indicating the second spindle speed % selected by program to the value of arithmetic parameter P111.



CNC 8055
CNC 8055i

.T- MODEL
(SOFT V16.1x)

11.2.12 Variables associated with the live tool

Read-only variables

ASPROG

It must be used inside the subroutine associated with function M45.

It returns the rpm programmed by M45 S. When programming M45 alone, the variable takes the value of "0".

The ASPROG variable is updated just before executing the M45 function so it is already updated when executing its associated subroutine.

LIVRPM

It must be used when operating in TC mode.

It returns the rpm selected by the user for the live tool when in TC mode.

11.

11.2.13 PLC related variables

11.

HIGH-LEVEL LANGUAGE PROGRAMMING
Variables

It should be borne in mind that the PLC has the following resources:

- (I1 thru I256) Inputs.
- (O1 thru O256) Outputs.
- M1 thru M5957) Marks.
- (R1 thru R499) 32-bit registers.
- (T1 thru T256) Timers with a timing count in 32 bits.
- (C1 thru C256) Counters with a count in 32 bits.

If any variable is accessed which allows the status of a PLC variable to be read or modified (I,O,M,R,T,C), block preparation is interrupted and the CNC waits for this command to be executed in order to restart block preparation.

Read-only variables

PLCMSG

Returns the number of the active PLC message with the highest priority and will coincide with the number displayed on screen (1..128). If there is none, it returns 0.

(P110=PLCMSG)

It assigns to P100 the number of the active PLC message with the highest priority.

Read-and-write variables

PLCIn

This variable allows 32 PLC inputs to be read or modified starting with the one indicated (n).

The value of the inputs which are used by the electrical cabinet cannot be modified as their values are determined by it. Nevertheless, the status of the remaining inputs can be modified.

PLCO_n

This variable allows 32 PLC outputs to be read or modified starting from the one indicated (n).

(P110=PLCO 22)

It assigns to parameter P110 the value of outputs O22 through O53 (32 outputs) of the PLC.

(PLCO 22=\$F)

It sets outputs O22 through O25 to "1" and outputs O26 through O53 to "0".

Bit	31	30	29	28	27	26	25	24	23	22	...	5	4	3	2	1	0
	0	0	0	0	0	0	0	0	0	0	0	0	1	1	1	1
Output	53	52	51	50	49	48	47	46	45	44	27	26	25	24	23	22

PLCM_n

This variable allows 32 PLC marks to be read or modified starting from the one indicated (n).

PLCR_n

This variable allows the status of 32 register bits to be read or modified starting from the one indicated (n).

PLCT_n

This variable allows the timer count to be read or modified starting from the one indicated (n).

PLCC_n

This variable allows the counter count to be read or modified starting from the one indicated (n).



CNC 8055
CNC 8055i

.T- MODEL
(SOFT V16.1X)

PLCMMn

This variable permits reading or modifying the PLC mark (n).

(PLMM4=1)

It sets mark M4 to ·1· and leaves the rest untouched.

(PLCM4=1)

It sets mark M4 to ·1· and the following 31 marks (M5, through M35) to ·0·.

11.**HIGH-LEVEL LANGUAGE PROGRAMMING**
Variables**FAGOR** **CNC 8055**
CNC 8055i·T· MODEL
(SOFT V16.1X)

11.2.14 Variables associated with local parameters

The CNC allows 26 local parameters (P0-P25) to be assigned to a subroutine, by using mnemonics PCALL and MCALL. In addition to performing the required subroutine these mnemonics allow local parameters to be initialized.

Read-only variables

11.

CALLP

Allows us to know which local parameters have been defined and which have not, in the call to the subroutine by means of the PCALL or MCALL mnemonic.

The information will be given in the 26 least significant bits (bits 0-25), each of these corresponding to the local parameter of the same number; thus bit 12 corresponds to P12.

Each bit will indicate whether the corresponding local parameter has been defined (=1) or not (0).

Bit	31	30	29	28	27	26	25	24	23	22	...	5	4	3	2	1	0
	0	0	0	0	0	0	*	*	*	*	...	*	*	*	*	*	*

Example:

```

;Call to subroutine 20.
(PCALL 20, P0=20, P2=3, P3=5)
...
...
;Beginning of subroutine 20.
( SUB 20)
(P100 = CALLP)
...
...
    
```

In parameter P100 the following will be obtained:

0000	0000	0000	0000	0000	0000	0000	0000	1101	LSB
------	------	------	------	------	------	------	------	------	-----



CNC 8055
CNC 8055i

.T- MODEL
(SOFT V16.1x)

11.2.15 Sercos variables

They are used in the data exchange via Sercos between the CNC and the drives.

Read-only variables

TSVAR(X-C)
TSVARS
TSSVAR

It returns the third attribute of the Sercos variable corresponding to the "identifier". The third attribute is used in particular software applications and its information is coded according to the Sercos standard.

TSVAR(X-C) identifier ... for the axes.
TSVARS identifier ... for the main spindle.
TSSVAR identifier ... for the second spindle.

(P110=SVARX 40)

It assigns to parameter P110 the third attribute of the Sercos variable of identifier 40 of the X axis which corresponds to "VelocityFeedback"

Write variables

SETGE(X-C)
SETGES
SSETGS

The drive may have up to 8 gear ratios (0 through 7). Sercos identifier 218, GearRatioPreselection.

It may also have up to 8 parameter sets (0 through 7). Sercos identifier 217, ParameterSetPreselection.

With these variables the work range or gear ratio and the parameter set of each drive may be modified.

SETGE(X-C) ... for the axes.
SETGES ... for the main spindle.
SSETGS ... for the second spindle

The 4 least significant bits of these variables indicate the gear ratio and the other 4 the parameter set to be selected.

Read-and-write variables

SVAR(X-C)
SVARS
SSVARS

They permit reading or modifying the value of the Sercos variable corresponding to the axis identifier.

SVAR(X-C) identifier ... for the axes.
SVARS identifier ... for the main spindle.
SSVARS identifier ... for the second spindle.

11.

HIGH-LEVEL LANGUAGE PROGRAMMING
Variables

FAGOR 

CNC 8055
CNC 8055i

.T- MODEL
(SOFT V16.1X)

11.2.16 Software & hardware configuration variables

Read-only variables

HARCON

It indicates, with bits, the CNC's hardware configuration. The bit will be "1" when the relevant configuration is available.

CNC8055 model:

Bit	Meaning	
0	Turbo board	
4,3,2,1	0000	8055 /A model
	0001	8055 /B model
	0010	8055 /C model
5	Sercos integrated into CPU board.	
6	Sercos module on manager board.	
7	Axes module.	
10,9,8	001	One I/O module.
	010	Two I/O modules.
	011	Three I/O modules.
	100	Four I/O modules.
11	Tracing module.	
13,12	01	Hard disk module (without Ethernet).
	10	Module with just Ethernet (without hard disk).
	11	Hard disk module with Ethernet.
14	It has analog video.	
15	It has CAN integrated into the CPU board.	
18,17,16	Keyboard type (technical service department).	
20,19	CPU type (technical service department).	
23,22,21	000	Memkey card (4 Mb).
	010	Memkey card (24 Mb).
	011	There is no "Memkey Card".
	110	Memkey card (512 Kb).
	111	Memkey card (2 Mb).
26,25,24	000	Color LCD Monitor.
	001	Monochrome LCD monitor.
28,27	00	Turbo board at 25 MHz
	01	Turbo board at 40 MHz
29	Hard disk integrated into the CPU.	
30	Ethernet connector integrated in the CPU.	
31	Compact flash.	

11.

HIGH-LEVEL LANGUAGE PROGRAMMING
Variables



CNC 8055
CNC 8055i

.T- MODEL
(SOFT V16.1x)

CNC8055i model:

Bit	Meaning	
0	Turbo board.	
4, 3, 2, 1	0101	8055i /B model.
	0110	8055i /C model.
5	Sercos (digital model).	
6	Reserved.	
9, 8, 7	000	Expansion board missing.
	001	"Feedback + I/O" expansion board.
	010	Feedback-only expansion board.
	011	I/O-only expansion board.
	101	"Axes 2" board for expansion of "feedback + I/O".
	110	"Axes 2" board for expansion of feedback only.
	111	"Axes 2" board for expansion of I/O only.
10	Axis board with 12-bit (=0) or 16-bit (=1) Digital/Analog converter.	
12, 11	Reserved.	
14, 13	Reserved.	
15	It has CAN (digital module).	
18,17,16	Keyboard type (technical service department).	
20,19	CPU type (technical service department).	
23,22,21	000	Memkey card (4 Mb).
	010	Memkey card (24 Mb).
	011	There is no "Memkey Card".
	110	Memkey card (512 Kb).
	111	Memkey card (2 Mb).
26,25,24	000	Color LCD Monitor.
	001	Monochrome LCD monitor.
28,27	00	Turbo board at 25 MHz
	01	Turbo board at 40 MHz
30	Ethernet..	
31	Compact flash.	

HARCOA

It indicates, with bits, the CNC's hardware configuration. The bit will be "1" when the relevant configuration is available.

CNC8055 model:

Bit	Meaning
0	Axis module 2.
1	It has a connector for compact flash.
10	The axis board is "Axis module SB" Note: Bit 0 of HARCOA must be set to 0.

Bit · 1 · only indicates whether the hardware has a connector for the compact flash or not, it does not indicate whether the compact flash is inserted or not.

CNC8055i model:

Bit	Meaning
0	"Axes 2" board.
1	It has a connector for compact flash.
10	The axis board is "Axis module SB" Note: Bit 0 of HARCOA must be set to 0.

Bit · 1 · only indicates whether the hardware has a connector for the compact flash or not, it does not indicate whether the compact flash is inserted or not.

11.

HIGH-LEVEL LANGUAGE PROGRAMMING
Variables



CNC 8055
CNC 8055i

· T · MODEL
(SOFT V16.1X)

11.

HIGH-LEVEL LANGUAGE PROGRAMMING Variables

IDHARH
IDHARL

They return, in BCD code, the hardware identification number corresponding to the Memkey card. It is the number appearing on the software diagnosis screen.

Since the identification number has 12 digits, the IDHARL variable shows the 8 least significant bits and the IDHARH the 4 most significant bits.

Example:

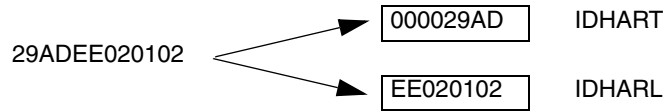

SOFCON

They return the software version numbers for the CNC and the hard disk.

Bits 15-0 return the CNC software version (4 digits)

Bits 31-16 return the software version of the hard disk (HD) (4 digits)

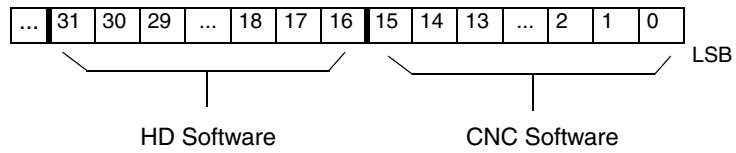

For example, SOFCON 01010311 indicates:

Hard disk (HD) software version	0101
CNC software version	0311

HDMEGA

It returns the size of the hard disk (in megabytes).

KEYIDE

Keyboard code, according to the auto-identification system.

KEYIDE	CUSTOMY (P92)	Keyboard
0	- - -	Keyboard without auto-identification.
130	254	Mill model keyboard.
131	254	Lathe model keyboard.
132	254	Conversational mill model keyboard.
133	254	Conversational lathe model keyboard.
134	254	Educational model keyboard.
135	252	Operator panel: OP.8040/55.ALFA
136	0	Operator panel: OP.8040/55.MC
137	0	Operator panel: OP.8040/55.TC
138	0	Operator panel: OP.8040/55.MCO/TCO



CNC 8055
CNC 8055i

.T- MODEL
(SOFT V16.1x)

11.2.17 Variables associated with telediagnosis

Read-only variables

HARSWA HARSWB

They return, in 4 bits, the central unit configuration, a value of "1" if it is present and "0" if not. Logic address (device select) set on each board with the dip-switches (see installation manual).

HARSWA

Bits	Board
31 - 28	Large sercos
27 - 24	I/O 4
23 - 20	I/O 3
19 - 16	I/O 2
15 - 12	I/O 1
11- 8	Axes:
7 -4	Turbo
3 - 0 (LSB)	CPU

HARSWB

Bits	Board
31 - 28	
27 - 24	
23 - 20	Type of CAN at COM1.
19 - 16	Type of CAN at COM2.
15 - 12	0 = CAN board missing 1 - CAN board in COM1 2 - CAN board in COM2 3 - Board in both COM
11- 8	Small sercos
7 -4	
3 - 0 (LSB)	HD

The CPU board must be present in all the configurations and set to "0". In the rest of cases, it returns a "0" if the board is missing.

The Sercos board may be large (occupying the whole module) or small installed in the CPU module ("1" if connected to COM1 or "2" if connected to COM2).

There may be two types of CAN boards (value of ·0001· if it is an SJ1000 type and value of ·0010· if it is an OKI9225 type).

HARTST

It returns the result of the hardware test. The data comes at the least significant bits with a "1" if it failed and with a "0" if OK or if the relevant board is missing.

Bits		
14	24V test of IO4 module	
13	Inside temperature	
12	I/O 3	(Board voltage)
11	I/O 2	(Board voltage)
10	I/O 1	(Board voltage)
9		
8	Axes:	(Board voltage)
7	+3.3 V	(Power supply)
6	GND	(Power supply)
5	GNDA	(Power supply)
4	- 15 V	(Power supply)
3	+ 15 V	(Power supply)
2	Battery	(Power supply)
1	- 5 V	(Power supply)
0 (LSB)	+ 5 V	(Power supply)

11.

11.

HIGH-LEVEL LANGUAGE PROGRAMMING
Variables

MEMTST

It returns the result of the memory test. Each data uses 4 bits that will be at "1" if the test is OK and will have a value other than "1" if there is an error.

Bits	Test	Bits	Test
30	Test status	15 - 12	Sdram
...	...	11- 8	HD
...	...	7 -4	Flash
19 - 16	Caché	3 - 0 (LSB)	Ram

Bit 30 stays at "1" during the test.

NODE

It returns the number of the node assigned to the CNC in the Sercos ring.

VCHECK

It returns the checksum of the code for the software version installed. It is the value appearing on the code test.

IONODE

It returns in 16 bits the position of the "ADDRESS" switch of the CAN of the I/O. If it is not connected, it returns the value 0xFFFF.

IOSLOC

They may be used to read the number of local digital I/O available.

Bit	Meaning
0 - 15	Number of inputs.
16 - 31	Number of outputs.

IOSREM

They may be used to read the number of remote digital I/O available.

Bit	Meaning
0 - 15	Number of inputs.
16 - 31	Number of outputs.



CNC 8055
CNC 8055i

.T- MODEL
(SOFT V16.1x)

11.2.18 Operating-mode related variables

Read-only variables related to the standard mode

OPMODE

It returns the code corresponding to the selected operating mode.

0 = Main menu.

10 = Automatic execution.

11 = Single block execution.

12 = MDI in EXECUTION.

13 = Tool inspection.

14 = Repositioning.

15 = Block search executing G.

16 = Block search executing G, M, S, T.

20 = Theoretical path simulation.

21 = G function simulation.

22 = G, M, S and T function simulation.

23 = Simulation with movement in the main plane.

24 = Simulation with rapid movement.

25 = Rapid simulation with S=0.

30 = Normal editing.

31 = User editing.

32 = TEACH-IN editing.

33 = Interactive editor.

34 = Profile editor.

40 = Movement in continuous JOG.

41 = Movement in incremental JOG.

42 = Movement with electronic handwheel.

43 = HOME search in JOG.

44 = Position preset in JOG.

45 = Tool calibration.

46 = MDI in JOG.

47 = User JOG operation.

50 = Zero offset table.

51 = Tool offset table.

52 = Tool table.

53 = Tool magazine table.

54 = Global parameter table.

55 = Local parameter table.

56 = User parameter table.

57 = OEM parameter table.

60 = Utilities.

70 = DNC status.

71 = CNC status.

11.

HIGH-LEVEL LANGUAGE PROGRAMMING
Variables

FAGOR 

**CNC 8055
CNC 8055i**

·T· MODEL
(SOFT V16.1X)

11.

HIGH-LEVEL LANGUAGE PROGRAMMING
 Variables

- 80 = PLC file editing.
- 81 = PLC program compilation.
- 82 = PLC monitoring.
- 83 = Active PLC messages.
- 84 = Active PLC pages.
- 85 = Save PLC program.
- 86 = Restore PLC program.
- 87 = PLC usage maps.
- 88 = PLC statistics.

- 90 = Customizing.

- 100 = General machine parameter table.
- 101 = Axis machine parameter tables.
- 102 = Spindle machine parameter table.
- 103 = Serial port machine parameter tables.
- 104 = PLC machine parameter table.
- 105 = M function table.
- 106 = Leadscrew error compensation tables and cross compensation tables.
- 107 = Machine parameter table for Ethernet.

- 110 = Diagnosis: configuration.
- 111 = Diagnosis: hardware test.
- 112 = Diagnosis: RAM memory test.
- 113 = Diagnosis: Flash memory test.
- 114 = User diagnosis.
- 115 = Hard disk diagnosis (HD).
- 116 = Circle geometry test.
- 117 = Oscilloscope.

Read-only variables related to the conversational mode (TC, TCO) and configurable mode M, T ([SHIFT]-[ESC])

In these work modes, it is recommended to use variables OPMODA, OPMODB and OPMODC. The OPMODE variable is generic and contains different values to those of the standard mode.

OPMODE

It returns the code corresponding to the selected operating mode.

- 0 = CNC starting up.
- 10 = In execution mode.
 - In execution or waiting for the [CYCLE START] key (drawing of the [CYCLE START] on top).
- 21 = In graphic simulation mode.
- 30 = Cycle editing.
- 40 = In Jog mode (standard screen).
- 45 = In tool calibration mode.
- 60 = Managing parts. PPROG mode.



CNC 8055
CNC 8055i

.T- MODEL
(SOFT V16.1X)

OPMODA

Indicates the operating mode currently selected when working with the main channel.

Use the OPMODE variable to know at any time the selected operating mode (main channel, user channel, PLC channel).

This information is given at the least significant bits with a "1" when active and with a "0" when not active or when it is not available in the current version.

- Bit 0 Program in execution.
- Bit 1 Program in simulation.
- Bit 2 Block in execution via MDI, JOG.
- Bit 3 Repositioning in progress.
- Bit 4 Program interrupted by CYCLE STOP.
- Bit 5 MDI, JOG block interrupted.
- Bit 6 Repositioning interrupted.
- Bit 7 In tool inspection.
- Bit 8 Block in execution via CNCEX1.
- Bit 9 CNCEX1 block interrupted.
- Bit 10 CNC ready to accept JOG movements: jog, handwheel, teach-in, inspection.
- Bit 11 CNC ready to receive the CYCLE START command: execution, simulation and MDI modes.
- Bit 12 The CNC is not ready to execute anything involving axis or spindle movement.
- Bit 13 It identifies the block search.

OPMODB

Indicates the type of simulation currently selected. This information is given at the least significant bits indicating with a "1" the one currently selected.

- Bit 0 Theoretical path.
- Bit 1 G functions.
- Bit 2 G M S T functions.
- Bit 3
- Bit 4 Rapid.
- Bit 5 Rapid (S=0).

OPMODC

Indicates the axes selected by handwheel. This information is given at the least significant bits indicating with a "1" the one currently selected.

- Bit 0 Axis 1.
- Bit 1 Axis 2.
- Bit 2 Axis 3.
- Bit 3 Axis 4.
- Bit 4 Axis 5.
- Bit 5 Axis 6.
- Bit 6 Axis 7.
- Bit 7
- Bit 8

The axis name corresponds to the number according to the programming order for them.

Example: If the CNC controls axes X, Y, Z, U, B, C, axis 1=X, axis2=Y, axis3=Z, axis4=U, axis5=B, axis6=C.

11.

HIGH-LEVEL LANGUAGE PROGRAMMING Variables



**CNC 8055
CNC 8055i**

·T· MODEL
(SOFT V16.1X)

11.2.19 Other variables

11.

HIGH-LEVEL LANGUAGE PROGRAMMING Variables

Read-only variables

NBTOOL

Indicates the tool number being managed. This variable can only be used within the tool change subroutine.

Example: There is a manual tool changer. Tool T1 is currently selected and the operator requests tool T5.

The subroutine associated with the tools may contain the following instructions:

```
(P103 = NBTOOL)
(MSG "SELECT T?P103 AND PRESS CYCLE START")
```

Instruction (P103 = NBTOOL) assigns the number of the tool currently being managed to parameter P103. Therefore, P103=5

The message displayed by the CNC will be ""SELECT T5 AND PRESS CYCLE START".

PRGN

Returns the program number being executed. Should none be selected, a value of -1 is returned.

BLKN

It returns the label number of the last executed block.

GSn

Returns the status of the G function indicated (n). 1 if it is active and 0 if not.

```
(P120=GS17)
```

It assigns the value 1 to parameter P120 if the G17 function is active and 0 if not.

MSn

Returns the status of the M function indicated (n). 1 if it is active and 0 if not.

These functions are M00, M01, M02, M03, M04, M05, M06, M08, M09, M19, M30, M41, M42, M43, M44 and M45.

PLANE

Returns data on the abscissa axis (bits 4 to 7) and the ordinate axis (bits 0 to 3) of the active plane in 32 bits and in binary.

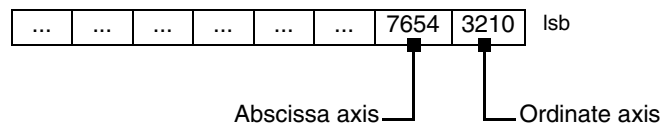

The axes are coded in 4 bits and indicate the axis number according to the programming order.

Example: If the CNC controls the X,Y,Z,U,B,C axes and the ZX plane (G18) is selected.

(P122 = PLANE) assigns the value of \$31 to parameter P122.

0000	0000	0000	0000	0000	0000	0011	0001	LSB
------	------	------	------	------	------	------	------	-----

Abscissa axis = 3 (0011) => Z axis

Ordinate axis = 1 (0001) => X axis

MIRROR

Returns in the least significant bits of the 32-bit group, the status of the mirror image of each axis, 1 in the case of being active and 0 if not.

Bit 8	Bit 7	Bit 6	Bit 5	Bit 4	Bit 3	Bit 2	Bit 1	Bit 0	LSB
		Axis 7	Axis 6	Axis 5	Axis 4	Axis 3	Axis 2	Axis 1	

The axis name corresponds to the number according to the programming order for them.



CNC 8055
CNC 8055i

.T- MODEL
(SOFT V16.1X)

Example: If the CNC controls axes X, Y, Z, U, B, C, axis 1=X, axis2=Y, axis3=Z, axis4=U, axis5=B, axis6=C.

SCALE	It returns the general scaling factor being applied.
SCALE(X-C)	Returns the specific scaling factor of the indicated axis (X-C).
PRBST	<p>Returns probe status.</p> <p>0 = the probe is not touching the part.</p> <p>1 = the probe is touching the part.</p> <p>If this variable is accessed, block preparation is interrupted and the CNC waits for this command to be executed to resume block preparation.</p>
CLOCK	<p>Returns the time in seconds indicated by the system clock. Possible values 0..4294967295.</p> <p>If this variable is accessed, block preparation is interrupted and the CNC waits for this command to be executed to resume block preparation.</p>
TIME	<p>Returns the time in hours-minutes-seconds format.</p> <div style="background-color: #ffffcc; padding: 5px; margin: 10px 0;"> <p>(P150=TIME)</p> <p>Loads P150 with hh-mm-ss. For example if the time is: 34sec. P150 = 182234.</p> </div> <p>If this variable is accessed, block preparation is interrupted and the CNC waits for this command to be executed to resume block preparation.</p>
DATE	<p>Returns the date in year-month-day format.</p> <div style="background-color: #ffffcc; padding: 5px; margin: 10px 0;"> <p>(P151=DATE)</p> <p>It assigns to P151 the year-month-day. For example if the date is April 25th 1992, P151 = 920425.</p> </div> <p>If this variable is accessed, block preparation is interrupted and the CNC waits for this command to be executed to resume block preparation.</p>
CYTIME	<p>It returns the amount of time (in hundredths of a second) elapsed executing the part. It ignores the time the execution has been interrupted. Possible values 0..4294967295.</p> <p>If this variable is accessed, block preparation is interrupted and the CNC waits for this command to be executed to resume block preparation.</p>
FIRST	<p>Indicates whether it is the first time that a program has been run or not. It returns a value of 1 if it is the first time and 0 if not.</p> <p>A first-time execution is considered as being one which is done:</p> <ul style="list-style-type: none"> • After turning on the CNC. • After pressing [SHIFT]+[RESET]. • Every time a new program is selected.
ANAI_n	<p>It returns the status of the indicated analog input (n). The value given in Volts and in ±1.4 format.</p> <ul style="list-style-type: none"> • At the –Axes– module, it is possible to select one of the 8 analog inputs (1-8) available. The values returned will be within the ±5 V range. • At the –Vpp Axes– module, it is possible to select one of the 4 analog inputs (1-4) available. The returned values will be either within the ±5 V or ±10 V range depending on how the analog inputs have been set. <p>If this variable is accessed, block preparation is interrupted and the CNC waits for this command to be executed to resume block preparation.</p>

11.

HIGH-LEVEL LANGUAGE PROGRAMMING

Variables



CNC 8055
CNC 8055i

·T· MODEL
(SOFT V16.1X)

11.

HIGH-LEVEL LANGUAGE PROGRAMMING Variables

AXICOM

It returns in the 3 least significant bits the axis pairs switched with function G28.

		Pair 3		Pair 2		Pair 1		
		Axis 2	Axis 1	Axis 2	Axis 1	Axis 2	Axis 1	LSB

The axes are coded in 4 bits and indicate the axis number (1 to 7) according to their programming order.

If the CNC controls the X, Z, C, W axes and G28 ZW has been programmed, the AXICOM variable will show:

		Pair 3		Pair 2		Pair 1		
						W	Z	LSB
		0000	0000	0000	0000	0101	0100	

TANGAN

Variable associated with the tangential control function, G45. It indicates the programmed angular position.

TPIOUT(X-C)

Output of the PI of the tandem master axis in rpm.

TIMEG

It shows the timing status of the timer programmed with G4 K in the CNC channel. This variable, returns the time remaining to end the timing block in hundredths of a second.

TIPPRB

It indicates the PROBE cycle being executed at the CNC.

PANEDI

WINDRAW55 application. Number of the screen created by the user or the manufacturer and is being consulted.

DATEDI

WINDRAW55 application. Number of the element (item) being consulted.

RIP

Linear theoretical feedrate resulting from the next loop (in mm/min).

The calculation of the resulting feedrate ignores the rotary axes, slave axes (gantry, coupled and synchronized) as well as DRO axes.

TEMPIn

It returns the temperature in tenths of a degree detected by the PT100. It is possible to select one of the 4 temperature inputs (1..4) available.

Read-and-write variables

TIMER

This variable allows reading or modifying the time, in seconds, indicated by the clock enabled by the PLC. Possible values 0..4294967295.

If this variable is accessed, block preparation is interrupted and the CNC waits for this command to be executed to resume block preparation.

PARTC

The CNC has a part counter whose count increases, in all modes except simulation, every time M30 or M02 is executed and this variable allows its value to be read or modified. This value will be between 0 and 4294967295

If this variable is accessed, block preparation is interrupted and the CNC waits for this command to be executed to resume block preparation.

KEY

Returns the code of the last key accepted.

This variable may be used as a write variable only inside a customizing program (user channel).

If this variable is accessed, block preparation is interrupted and the CNC waits for this command to be executed to resume block preparation.



CNC 8055
CNC 8055i

.T- MODEL
(SOFT V16.1X)

KEYSRC This variable allows reading or modifying the source of keystrokes, possible values being:

- 0 = Keyboard.
- 1 = PLC.
- 2 = DNC.

The CNC only allows modification of this variable if this is at 0.

ANAO_n This variable allows the required analog output (n) to be read or modified. The value assigned will be expressed in volts and in the ±2.4 format (±10 V).

The analog outputs which are free among the eight (1 through 8) available at the CNC may be modified, the corresponding error being displayed if an attempt is made to write in one which is occupied.

If this variable is accessed, block preparation is interrupted and the CNC waits for this command to be executed to resume block preparation.

SELPRO When having two probe inputs, it allows selecting the active input.

On power-up, it assumes the value of ·1· thus selecting the first probe input. To select the second probe input, set it to a value of ·2·.

Accessing this variable from the CNC interrupts block preparation.

DIAM It changes the programming mode for X axis coordinates between radius and diameter. When changing the value of this variable, the CNC assumes the new way to program the following blocks.

When the variable is set to ·1·, the programmed coordinates are assumed in diameter; when is set to ·0·, the programmed coordinates are assumed in radius.

This variable affects the display of the real value of the X axis in the coordinate system of the part and the reading of variables PPOSX, TPOSX and POSX.

On power-up, after executing an M02 or M30 and after an emergency or a reset, the variable is initialized according to the value of the DFORMAT parameter of the X axis. If this parameter has a value equal to or greater than 4, the variable takes a value of 1; otherwise, it takes the value of ·0·.

PRBMOD It indicates whether a probing error is to issued or not in the following cases, even if general machine parameter PROBERR (P119) =YES.

- When a G75 probing move finishes before the probe has touched part.
- When a G76 probing move finishes but the probe is still touching the part.

The PRBMOD variable takes the following values.

Value	Meaning
0	An error message is issued.
1	No error message is issued.

Default value 0.

The PRBMOD variable can be read and written from the CNC and the PLC an read from the DNC.

11.



CNC 8055
CNC 8055i

·T· MODEL
(SOFT V16.1X)

11.3 Constants

Constants are defined as being all those fixed values which cannot be altered by a program. The following are considered as constants:

- Numbers expressed in the decimal system.
- Hexadecimal numbers.
- PI constant.
- Read-only tables and variables as their value cannot be altered with a program.

11.

11.4 Operators

An operator is a symbol that indicates the mathematical or logic operations to carry out. The CNC has arithmetic, relational, logic, binary, trigonometric operators and special operators.

Arithmetic operators.

+	add.	P1=3 + 4	P1=7
-	subtraction, also a negative value.	P2=5 - 2 P3= -(2 * 3)	P2=3 P3=-6
*	multiplication.	P4=2 * 3	P4=6
/	division.	P5=9 / 2	P5=4.5
MOD	Module or remainder of the division.	P6=7 MOD 4	P6=3
EXP	exponential.	P7=2 EXP 3	P7=8

Relational operators.

EQ	equal.
NE	different.
GT	greater than.
GE	greater than or equal to.
LT	Less than.
LE	Less than or equal to.

Logic and binary operators.

NOT, OR, AND, XOR: The act as logic operators between conditions and as binary operators between variables and constants.

```
IF (FIRST AND GS1 EQ 1) GOTO N100
P5 = (P1 AND (NOT P2 OR P3))
```



CNC 8055
CNC 8055i

.T- MODEL
(SOFT V16.1X)

Trigonometric functions.

SIN	sine.	P1=SIN 30	P1=0.5
COS	cosine.	P2=COS 30	P2=0.8660
TAN	tangent.	P3=TAN 30	P3=0.5773
ASIN	arc sine.	P4=ASIN 1	P4=90
ACOS	arc cosine.	P5=ACOS 1	P5=0
ATAN	arc tangent.	P6=ATAN 1	P6=45
ARG	ARG(x,y) arctangent y/x.	P7=ARG(-1,-2)	P7=243.4349

There are two functions for calculating the arc tangent ATAN which returns the result between ±90° and ARG given between 0 and 360°.

Other functions.

ABS	absolute value.	P1=ABS -8	P1=8
LOG	decimal logarithm.	P2=LOG 100	P2=2
SQRT	square root.	P3=SQRT 16	P3=4
ROUND	rounding up an integer number.	P4=ROUND 5.83	P4=6
FIX	Integer.	P5=FIX 5.423	P5=5
FUP	if integer takes integer. if not, takes entire part + 1.	P6=FUP 7 P6=FUP 5,423	P6=7 P6=6
BCD	converts given number to BCD.	P7=BCD 234	P7=564

0010	0011	0100
------	------	------

BIN	converts given number to binary.	P8=BIN \$AB	P8=171
-----	----------------------------------	-------------	--------

1010	1011
------	------

Conversions to binary and BCD are made in 32 bits, it being possible to represent the number 156 in the following formats:

decimal	156
Hexadecimal	9C
Binary	0000 0000 0000 0000 0000 0000 1001 1100
BCD	0000 0000 0000 0000 0000 0001 0101 0110

11.



CNC 8055
CNC 8055i

.T- MODEL
(SOFT V16.1X)

11.5 Expressions

An expression is any valid combination of operators, constants, parameters and variables.

All expressions must be placed between brackets, but if the expression is reduced to an integer, the brackets can be removed.

11.5.1 Arithmetic expressions

These are formed by combining functions and arithmetic, binary and trigonometric operators with the constants and variables of the language.

The priorities of the operators and the way they can be associated determine how these expressions are calculated:

Priority from highest to lowest	To be associated
NOT, functions, - (negative)	from right to left.
EXP, MOD	from left to right.
*, /	from left to right.
+,- (add, subtract)	from left to right.
Relational operators	from left to right.
AND, XOR	from left to right.
OR	from left to right.

Brackets should be used in order to clarify the order in which the expression is to be evaluated.

$$(P3 = P4/P5 - P6 * P7 - P8/P9)$$

$$(P3 = (P4/P5) - (P6 * P7) - (P8/P9))$$

Using redundant or additional brackets will neither cause errors nor slow down the execution.

In functions, brackets must be used except when these are applied to a numerical constant, in which case they are optional.

(SIN 45) (SIN (45)) they're both valid and equivalent.
 (SIN 10+5) the same as ((SIN 10)+5).

Expressions can be used also to reference parameters and tables:

```
(P100 = P9)
(P100 = P(P7))
(P100 = P(P8 + SIN(P8 * 20)))
(P100 = ORGX 55)
(P100 = ORGX (12+P9))
(PLCM5008 = PLCM5008 OR 1)
; Selects single block execution mode (M5008=1)
(PLCM5010 = PLCM5010 AND $FFFFFFE)
; Frees feedrate override (M5010=0)
```

11.
HIGH-LEVEL LANGUAGE PROGRAMMING
 Expressions



CNC 8055
CNC 8055i

.T- MODEL
 (SOFT V16.1x)

11.5.2 Relational expressions

These are arithmetic expressions joined by relational operators.

(IF (P8 EQ 12.8)

; It checks if the value of P8 is equal to 12.8.

(IF (ABS(SIN(P24)) GT SPEED)

;Analyzes if the sine is greater than the spindle speed.

(IF (CLOCK LT (P9 * 10.99))

; Analyzes if the clock count is less than (P9 * 10.99)

At the same time these conditions can be joined by means of logic operators.

(IF ((P8 EQ 12.8) OR (ABS(SIN(P24)) GT SPEED)) AND (CLOCK LT (P9 * 10.99)) ...

The result of these expressions is either true or false.

11.

11.

HIGH-LEVEL LANGUAGE PROGRAMMING

Expressions



CNC 8055
CNC 8055i

.T- MODEL
(SOFT V16.1X)

The control instructions available to high-level programming can be grouped as follows:

- Assignment instructions.
- Display instructions.
- Enable-disable instructions.
- Flow control instructions.
- Subroutine instructions.
- Probe related instructions.
- Interruption-subroutine instructions.
- Program instructions.
- Screen customizing instructions.

Only one instruction can be programmed in each block, and no other additional information may be programmed in this block.

12.1 Assignment instructions

This is the simplest type of instruction and can be defined as:

(target = arithmetic expression)

A local or global parameter or a read-write variable may be selected as target. The arithmetic expression may be as complex as required or a simple numerical constant.

(P102 = FZLOX)

(ORGX 55 = (ORGX 54 + P100))

In the specific case of designating a local parameter using its name (A instead of P0, for example) and the arithmetic expression being a numerical constant, the instruction can be abbreviated as follows:

(P0=13.7) ==> (A=13.7) ==> (A13.7)

Within a single block, up to 26 assignments can be made to different targets, a single assignment being interpreted as the set of assignments made to the same target.

(P1=P1+P2, P1=P1+P3, P1=P1*P4, P1=P1/P5)

It is the same as saying:

(P1=(P1+P2+P3)*P4/P5).

The different assignments which are made in the same block will be separated by commas ",".

12.

12.2 Display instructions

(ERROR integer, "error text")

This instruction stops the execution of the program and displays the indicated error, it being possible to select this error in the following ways:

(ERROR integer)

This will display the error number indicated and the text associated to this number according to the CNC error code (should there be one).

(ERROR integer, "error text")

This will display the number and the error text indicated, it being necessary to write the text between quote marks "".

(ERROR "error text").

This will display the error text only.

The error number may be defined by means of a numerical constant or an arithmetic parameter. When using a local parameter, its numeric format must be used (P0 thru P25 instead of A thru Z).

Programming examples:

(ERROR 5)

(ERROR P100)

(ERROR "User error")

(ERROR 3, "User error")

(ERROR P120, "User error")

(MSG "message")

This instruction will display the message indicated between quote marks.

The CNC screen is provided with an area for displaying DNC or user program messages, and always displays the last message received irrespective of where it has come from.

Example: (MSG "Check tool")

(DGWZ expression 1, expression 2, expression 3, expression 4)

The DGWZ instruction (Define Graphic Work Zone) defines the graphics area.

Each expression forming the instruction syntax correspond to one of the limits and they must be defined in millimeters or inches.

expression 1	Z minimum
expression 2	Z maximum
expression 3	Inside radius or inside diameter.
expression 4	Outside radius or outside diameter.

12.

12.3 Enable-disable instructions

12.

(ESBLK and DSBLK)

After executing the mnemonic ESBLK, the CNC executes all the blocks that come after as if it were dealing with a single block.

This single block treatment is kept active until it is cancelled by executing the mnemonic DSBLK.

In this way, should the program be executed in the SINGLE BLOCK operating mode, the group of blocks which are found between the mnemonics ESBLK and DSBLK will be executed in a continuous cycle, i.e., execution will not be stopped at the end of a block but will continue by executing the following one.

```
G01 X30 Z10 F1000 T1 D1
(ESBLK) ; Start of single block
G01 X20 Z10
G01 X20 Z20
G02 X10 Z30 I-10 K0
(DSBLK) ; Cancellation of single block
G01 X10 Z40
M30
```

(ESTOP and DSTOP)

After executing the mnemonic DSTOP, the CNC enables the Stop key, as well as the Stop signal from the PLC.

It will remain disabled until it is enabled once again by means of the mnemonic ESTOP.

(EFHOLD and DFHOLD)

After executing the mnemonic DFHOLD, the CNC enables the Feed-Hold input from the PLC.

It will remain disabled until it is enabled once again by means of the mnemonic EFHOLD.



CNC 8055
CNC 8055i

.T- MODEL
(SOFT V16.1X)

12.4 Flow control instructions

The GOTO and RPT instructions cannot be used in programs that are executed from a PC connected through the serial lines.

(GOTO N(expression))

The mnemonic GOTO causes a jump within the same program, to the block defined by the label N(expression). The execution of the program will continue after the jump, from the indicated block.

The jump label can be addressed by means of a number or by any expression which results in a number.

```
G00 X30 Z10 T2 D4
X30 Z20
(GOTO N22) ; Jump instruction
X20 Z20 ; It is not executed
X20 Z10 ; It is not executed
N22 G01 X10 Z10 F1000 ; Continues execution in this block
G02 X0 Z40 I-105 K0
...
```

(RPT N(expression), N(expression), P(expression))

The mnemonic RPT executes the part of the program between the blocks defined by means of the labels N(expression). The blocks to be executed may be in the execution program or in a RAM memory program.

The label P(expression) indicates the number of the program containing the blocks to be executed. If not defined, the CNC interprets that the portion to be repeated is located in the same program.

All the labels can be indicated by means of a number or by any expression which results in a number. The part of the program selected by means of the two labels must belong to the same program, by first defining the initial block and then the final block.

The execution of the program will continue in the block following the one in which the mnemonic RPT was programmed, once the selected part of the program has been executed.

```
N10 G00 X10
Z20
G01 X5
G00 Z0
N20 X0
N30 (RPT N10, N20) N3
N40 G01 X20
M30
```

When reaching block N30, the program will execute section N10-N20 three times. Once this has been completed, the program will continue execution in block N40.



Since the RPT instruction does not interrupt block preparation or tool compensation, it may be used when using the EXEC instruction and while needing to maintain tool compensation active.

12.

PROGRAM CONTROL INSTRUCTIONS
Flow control instructions



CNC 8055
CNC 8055i

·T· MODEL
(SOFT V16.1X)

12.

(IF condition <action1> ELSE <action2>)

This instruction analyzes the given condition that must be a relational expression. If the condition is true (result equal to 1), <action1> will be executed, otherwise (result equal to 0) <action2> will be executed.

Example:

```
(IF (P8 EQ 12.8) CALL 3 ELSE PCALL 5, A2, B5, D8)
```

If P8 = 12.8 executes the mnemonic (CALL3)

If P8 <> 12.8 executes the mnemonic (PCALL 5, A2, B5, D8)

The instruction can lack the ELSE part, i.e., it will be enough to program IF condition <action1>.

Example:

```
(IF (P8 EQ 12.8) CALL 3)
```

Both <action1> and <action2> can be expressions or instructions, except for mnemonics IF and SUB.

Due to the fact that in a high level block local parameters can be named by means of letters, expressions of this type can be obtained:

```
(IF (E EQ 10) M10)
```

If the condition of parameter P5 (E) having a value of 10 is met, the miscellaneous function M10 will not be executed, since a high level block cannot have ISO code commands. In this case M10 represents the assignment of value 10 to parameter P12, i.e., one can program either:

```
(IF (E EQ 10) M10) or (IF (P5 EQ 10) P12=10)
```

12.5 Subroutine instructions

A subroutine is a part of a program which, being properly identified, can be called from any position of a program to be executed.

A subroutine can be kept in the memory of the CNC as an independent part of a program and be called one or several times, from different positions of a program or different programs.

Only subroutines stored in the CNC's RAM memory can be executed. Therefore, to execute a subroutine stored in the Memkey Card, HD or in a PC connected through one of the serial lines, it must be copied first into the CNC's RAM memory.

If the subroutine is too large to be copied into RAM, it must be converted into a program and then the EXEC instruction must be used.

(SUB integer)

The SUB instruction defines as subroutine the set of program blocks programmed next until reaching the RET subroutine. The subroutine is identified with an integer which also defines the type of subroutine; either general or OEM.

Range of general subroutines SUB 0000 - SUB 9999

Range of OEM (manufacturer's) subroutines SUB 10000 - SUB 20000

The OEM subroutines are treated like the general ones, but with the following restrictions:

- They can only be defined in OEM programs, having the [O] attribute. Otherwise, the CNC will display the corresponding error.

Error 63 : Program subroutine number 1 thru 9999.

- To execute an OEM subroutine using CALL, PCALL or MCALL, it must be inside an OEM program. Otherwise, the CNC will display the corresponding error.

Error 1255 : Subroutine restricted to an OEM program.

There can not be two subroutines with the same identification number in the CNC memory, even when they belong to different programs.

(RET)

The mnemonic RET indicates that the subroutine which was defined by the mnemonic SUB, finishes in this block.

```
( SUB 12 )                                      ; Definition of subroutine 12
G91 G01 XP0 F5000
ZP1
XP0
ZP1
( RET )                                         ; End of subroutine
```

(CALL (expression))

The mnemonic CALL makes a call to the subroutine indicated by means of a number or by means of any expression that results in a number.

As a subroutine may be called from a main program, or a subroutine, from this subroutine to a second one, from the second to a third, etc..., the CNC limits these calls to a maximum of 15 nesting levels, it being possible to repeat each of the levels 9999 times.

12.

PROGRAM CONTROL INSTRUCTIONS
Subroutine instructions



CNC 8055
CNC 8055i

·T· MODEL
(SOFT V16.1X)

12.

PROGRAM CONTROL INSTRUCTIONS
Subroutine instructions

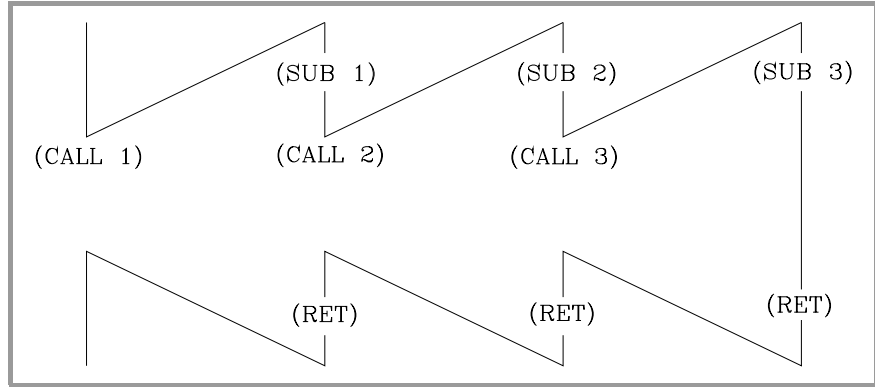

Programming example.

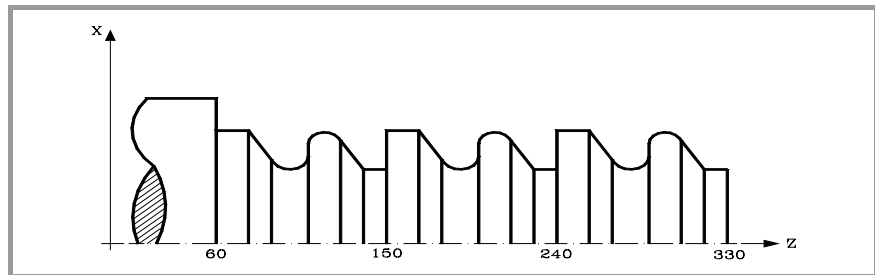

```
G90 G01 X100 Z330
(CALL 10)
G90 G01 X100 Z240
(CALL 10)
G90 G01 X100 Z150
M30

( SUB 10)
G91 G01 Z -10
X40 Z-10
G03 X0 Z-20 I0 K-10
G01 X-20
G02 X0 Z-20 I0 K-10
G01 X40 Z-10
Z-20
(RET)
```

(PCALL (expression), (assignment instruction), (assignment instruction),...)

The mnemonic PCALL calls the subroutine indicated by means of a number or any expression that results in a number. In addition, it allows up to a maximum of 26 local parameters of this subroutine to be initialized.

These local parameters are initialized by means of assignment instructions.

Example: (PCALL 52, A3, B5, C4, P10=20)

In this case, in addition to generating a new subroutine nesting level, a new local parameter nesting level will be generated, there being a maximum of 6 levels of local parameter nesting, within the 15 levels of subroutine nesting.

Both the main program and each subroutine that is found on a parameter nesting level, will have 26 local parameters (P0-P25).



CNC 8055
CNC 8055i

.T- MODEL
(SOFT V16.1X)

Programming example.

The X axis is programmed in diameter.

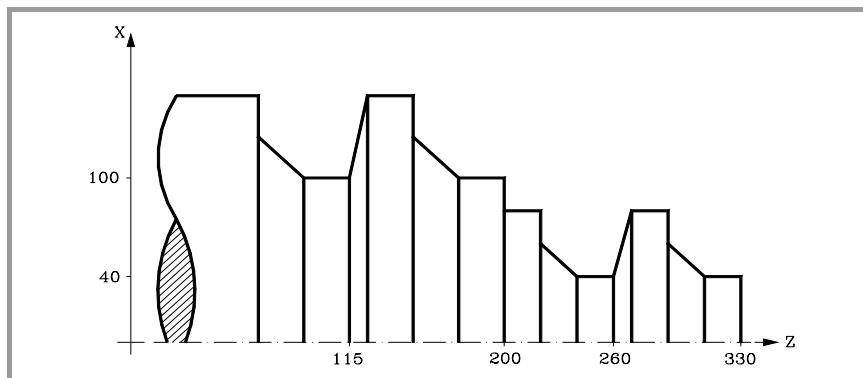

```
G90 G01 X80 Z330
(PCALL 10, P0=20, P1=-10) ; Also (PCALL 10, A20, B-10)
G90 G01 X80 Z260
(PCALL 10, P0=20, P1=-10) ; Also (PCALL 10, A20, B-10)
G90 G01 X200 Z200
(PCALL 10, P0=30, P1=-15) ; Also (PCALL 10, A30, B-15)
G90 G01 X200 Z115
(PCALL 10, P0=30, P1=-15) ; Also (PCALL 10, A30, B-15)
M30

( SUB 10 )
G91 G01 ZP1
XP0 ZP1
XP0
ZP1
(RET)
```

(MCALL (expression), (assignment instruction), (assignment instruction),...)

By means of the mnemonic MCALL, any user-defined subroutine (SUB integer) acquires the category of canned cycle.

The execution of this mnemonic is the same as the mnemonic PCALL, but the call is modal, i.e., if another block with axis movement is programmed at the end of this block, after this movement, the subroutine indicated will be executed and with the same call parameters.

If, when a modal subroutine is selected, a movement block with a number of repetitions is executed, for example X10 N3, the CNC will execute the movement only once (X10) and after the modal subroutine, as many times as the number of repetitions indicates.

Should block repetitions be chosen, the first execution of the modal subroutine will be made with updated call parameters, but not for the remaining times, which will be executed with the values which these parameters have at that time.

If, when a subroutine is selected as modal, a block containing the MCALL mnemonic is executed, the present subroutine will lose its modal quality and the new subroutine selected will be changed to modal.

(MDOFF)

The MDOFF instruction indicates that the mode assumed by a subroutine with the MCALL instruction or a part-program with MEXEC ends in that block.

The use of modal subroutines simplifies programming.

12.

PROGRAM CONTROL INSTRUCTIONS
Subroutine instructions



**CNC 8055
CNC 8055i**

·T- MODEL
(SOFT V16.1x)

12.

PROGRAM CONTROL INSTRUCTIONS
Subroutine instructions

Programming example.

The X axis is programmed in diameter.

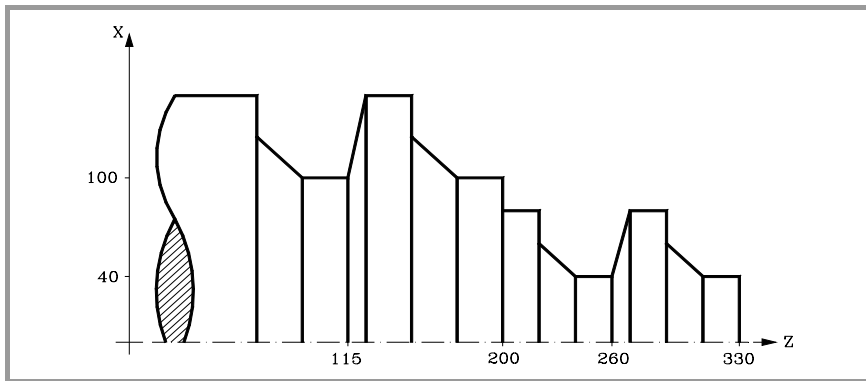

(P100=20, P101=-10)

G90 G01 X80 Z330

(MCALL 10)

G90 G01 X80 Z260

(P100=30, P101=-15)

G90 G01 X200 Z200

G90 G01 X200 Z115

(MDOFF)

M30

(SUB 10)

G91 G01 ZP101

XP100 ZP101

XP100

ZP101

(RET)



CNC 8055
CNC 8055i

.T- MODEL
(SOFT V16.1x)

12.6 Probe related instructions

(PROBE (expression), (assignment instruction), (assignment instruction),...)

The mnemonic PROBE calls the probe cycle indicated by means of a number or any expression that results in a number. In addition, it allows the local parameters of this subroutine to be initialized by means of assignment instructions.

This instruction also generates a new subroutine nesting level.

12.

PROGRAM CONTROL INSTRUCTIONS
Probe related instructions

FAGOR 

**CNC 8055
CNC 8055i**

·T· MODEL
(SOFT V16.1X)

12.7 Interruption-subroutine instructions

12.

Whenever one of the general interruption logic input is activated, "INT1" (M5024), "INT2" (M5025), "INT3" (M5026) or "INT4" (M5027), the CNC temporarily interrupts the execution of the program in progress and starts executing the interruption subroutine whose number is indicated by the corresponding general parameter.

With INT1 (M5024) the one indicated by machine parameter INT1SUB (P35)

With INT2 (M5025) the one indicated by machine parameter INT2SUB (P36)

With INT3 (M5026) the one indicated by machine parameter INT3SUB (P37)

With INT4 (M5027) the one indicated by machine parameter INT4SUB (P38)

The interruption subroutines are defined like any other subroutine by using the instructions: "(SUB integer)" and "(RET)".

These interruption subroutines do not change the nesting level of local parameters, thus only global parameters must be used in them.

Within an interruption subroutine, it is possible to use the "(REPOS X, Y, Z, ...)" instruction described next.

Once the execution of the subroutine is over, the CNC resumes the execution of the program which was interrupted.

(REPOS X, Y, Z, ...)

The REPOS instruction must always be used inside an interruption subroutine and facilitates the repositioning of the machine axes to the point of interruption.

When executing this instruction, the CNC moves the axes to the point where the program was interrupted.

Inside the REPOS instruction, indicate the order the axes must move to the point where the program was interrupted.

- The axes move one by one.
- It is not necessary to define all the axes, only those to be repositioned.
- The axes that make up the main plane of the machine move together. Both axes need not be defined because the CNC moves the first one. The movement is not repeated when defining the second one, it is ignored.

Example:

The main plane is formed by the X and Y axes, the Z axis is the longitudinal (perpendicular) axis and the machine uses the C and W axes as auxiliary axes. It is desired to first move the C axis, then the X and Y axes and finally the Z axis.

This repositioning move may be defined in any of the following ways:

(REPOS C, X, Y, Z)(REPOS C, X, Z)(REPOS C, Y, Z)

If the REPOS instruction is detected while executing a subroutine not activated by an interruption input, the CNC will issue the corresponding error message.



CNC 8055
CNC 8055i

.T- MODEL
(SOFT V16.1X)

12.8 Program instructions

With this CNC, from a program in execution, it is possible to:

- Execute another program. Instruction (EXEC P....)
- Execute another program in modal mode. Instruction (MEXEC P....)
- Generate a new program. Instruction (OPEN P....)
- Add blocks to an existing program. Instruction (WRITE P....)

(EXEC P(expression), (directory))

The EXEC P instruction executes the part-program of the indicated directory

The part-program may be defined by a number or any expression resulting in a number.

By default, the CNC interprets that the part-program is in the CNC's RAM memory. If it is in another device, it must be indicated in (directory).

CARD A	in the "Memkey CARD".
HD	in the Hard Disk.
DNC1	in a PC connected through serial line 1.
DNC2	in a PC connected through serial line 2.
DNCE	in a PC connected through Ethernet.

(MEXEC P(expression), (directory))

The MEXEC instruction executes the part-program of the indicated directory and it also becomes modal; i.e. if after this block, another one is programmed with axis movement; after this movement, it will execute the indicated program again.

The part-program may be defined with a number or with an expression whose result is a number.

By default, the CNC interprets that the part-program is in the CNC's RAM memory. If it is in another device, it must be so indicated in (directory):

CARD A	in the "Memkey CARD".
HD	in the Hard Disk.
DNC1	in a PC connected through serial line 1.
DNC2	in a PC connected through serial line 2.
DNCE	in a PC connected through Ethernet.

If while the modal part-program is selected, a motion block is executed with a number of repetitions (for example X10 N3), the CNC ignores the number of repetitions and executes the movement and the modal part-program only once.

If while a part-program is selected as modal, a block containing the MEXEC instruction is executed from the main program, the current part-program stops being modal and the part-program called upon with MEXEC will then become modal.

If within the modal part-program, an attempt is made to execute a block using the MEXEC instruction, it will issue the relevant error message.

1064: The program cannot be executed.

(MDOFF)

The MDOFF instruction indicates that the mode assumed by a subroutine with the MCALL instruction or a part-program with MEXEC ends in that block.

12.

PROGRAM CONTROL INSTRUCTIONS
Program instructions



CNC 8055
CNC 8055i

·T· MODEL
(SOFT V16.1X)

12.

(OPEN P(expression), (destination directory), A/D, "program comment")

The OPEN instruction begins editing a part-program. The part-program number may be indicated by a number or any expression resulting in a number.

By default, the new part-program edited will be stored in the CNC's RAM memory. To store it another device, it must be indicated in (destination directory).

- CARD A in the "Memkey CARD".
- HD in the Hard Disk.
- DNC1 in a PC connected through serial line 1.
- DNC2 in a PC connected through serial line 2.
- DNCE in a PC connected through Ethernet.

Parameter A/D is used when the program to be edited already exists.

- A The CNC appends the new blocks after the ones already existing.
- D The CNC deletes the existing program and starts editing a new one.

A program comment may also be associated with it; this comment will later be displayed next to it in the program directory.

The OPEN instruction allows generating a program from a program already in execution. That generated program will depend on the values assumed by the program being executed.

To edit blocks, the WRITE instruction must be used as described next.

Notes:

If the program to be edited already exists and the A/D parameters are not defined, the CNC will display an error message when executing the block.

The program opened with the OPEN instruction is closed when executing an M30, or another OPEN instruction and after an Emergency or Reset.

From a PC, only programs stored in the CNC'S RAM memory, in the CARD A, or in the Hard Disk module can be opened

(WRITE <block text>)

The mnemonic WRITE adds, after the last block of the program which began to be edited by means of the mnemonic OPEN P, the information contained in <block text> as a new program block.

When it is an ISO coded parametric block, all the parameters (global and local) are replaced by the numeric value they have at the time.

(WRITE G1 XP100 ZP101 F100) => G1 X10 Z20 F100

When it is a parametric block edited in high level, use the "?" character to indicate that the parameter is supposed to be replaced by the numeric value it has at the time.

(WRITE (SUB P102))	=>	(SUB P102)
(WRITE (SUB ?P102))	=>	(SUB 55)
(WRITE (ORGX54=P103))	=>	(ORGX54=P103)
(WRITE (ORGX54=?P103))	=>	(ORGX54=222)
(WRITE (PCALL P104))	=>	(PCALL P104)
(WRITE (PCALL ?P104))	=>	(PCALL 25)

If the mnemonic WRITE is programmed without having programmed the mnemonic OPEN previously, the CNC will display the corresponding error, except when editing a user customized program, in which case a new block is added to the program being edited.



CNC 8055
CNC 8055i

.T- MODEL
(SOFT V16.1x)

Example of how to create a program that contains several points of a parabolic path.

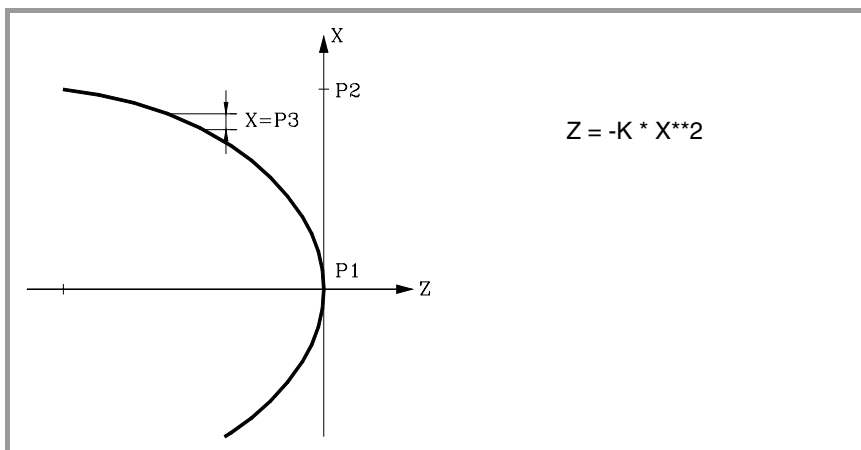

The X axis is programmed in diameter, it uses subroutine number 2 and its parameters have the following meaning:

Call parameters:

- A or P0 Value of the K constant.
- B or P1 Initial X coordinate.
- C or P2 Final X coordinate.
- D or P3 Increment or step in X.

Calculated parameters:

- E or P4 X coordinate.
- F or P5 Z coordinate.

A way to use this example could be:

```
G00 X0 Z0
(PCALL 2, A0.01, B0, C100, D1)
M30
```

Program generating subroutine.

```
( SUB 2)
(OPEN P12345) ; Starts editing of program P12345
(P4=P1)
N100 (IF (P4+P3 GE P2) P4=P2 ELSE P4=P4+P3)
(P5=-(P0 * P4 * P4))
(WRITE G01 XP4 ZP5) ; Movement block
(IF (P4 NE P2) GOTO N100)
(WRITE M30) ; End of program block
(RET) ; End of subroutine
```

12.

PROGRAM CONTROL INSTRUCTIONS
Program instructions



CNC 8055
CNC 8055i

·T· MODEL
(SOFT V16.1X)

12.9 Screen customizing instructions

Customizing instructions may be used only when customizing programs made by the user.

These customizing programs must be stored in the CNC'S RAM memory and they may utilize the "Programming Instructions" and they will be executed in the special channel designed for this use; the program selected in each case will be indicated in the following general machine parameters.

In "USERDPLY" the program to be executed in the Execution Mode will be indicated.

In "USEREDIT" the program to be executed in the Editing Mode will be indicated.

In "USERMAN" the program to be executed in the Manual (JOG) Mode will be indicated.

In "USERDIAG" the program to be executed in the Diagnosis Mode will be indicated.

The customizing programs may have up to five nesting levels besides their current one. Also, the customizing instructions do not allow local parameters, nevertheless all global parameters may be used to define them.

(PAGE (expression))

The mnemonic PAGE displays the page number indicated by means of a number or by means of any expression resulting in a number.

User-defined pages will be from page 0 to page 255 and will be defined from the CNC keyboard in the Graphic Editor mode and as indicated in the Operating Manual.

System pages will be defined by a number greater than 1000. See the corresponding appendix.

(SYMBOL (expression 1), (expression 2), (expression 3))

The mnemonic SYMBOL displays the symbol whose number is indicated by means of the value of expression 1 once this has been evaluated.

Its position on screen is also defined by expression 2 (column) and by expression 3 (row).

Expression 1, expression 2 and expression 3 may contain a number or any expression resulting in a number.

The CNC allows displaying any user-defined symbol (0-255) defined at the CNC keyboard in the Graphic Editor mode such as is indicated in the Operating Manual.

In order to position it within the display area its pixels must be defined, 0-639 for columns (expression 2) and 0-335 for rows (expression 3).

12.



CNC 8055
CNC 8055i

.T- MODEL
(SOFT V16.1x)

(IB (expression) = INPUT "text", format)

The CNC has 26 data entry variables (IB0-1B25)

The IB mnemonic displays the text indicated in the data input window and stores the data input by the user in the entry variable indicated by means of a number or by means of any expression resulting in a number.

The wait for data entry will only occur when programming the format of the requested data. This format may have a sign, integer part and decimal part.

If it bears the "-" sign, it will allow positive and negative values, and if it does not have a sign, it will only allow positive values.

The integer part indicates the maximum number of digits (0-6) desired to the left of the decimal point.

The decimal part indicates the maximum number of digits (0-5) desired to the right of the decimal point.

If the numerical format is not programmed; for example: (IB1 =INPUT "text"), the mnemonic will only display the indicated text without waiting for the data to be entered.

(ODW (expression 1), (expression 2), (expression 3))

The mnemonic ODW defines and draws a white window on the screen with fixed dimensions (1 row and 14 columns).

Each mnemonic has an associated number which is indicated by the value of expression 1 once this has been evaluated.

Likewise, its position on screen is defined by expression 2 (row) and by expression 3 (column).

Expression 1, expression 2 and expression 3 may contain a number or any expression resulting in a number.

The CNC allows 26 windows (0-25) to be defined and their positioning within the display area, providing 21 rows (0-20) and 80 columns (0-79).

(DW(expression 1) = (expression 2), DW (expression 3) = (expression 4), ...)

The instruction DW displays in the window indicated by the value for expression 1, expression 3, .. once they have been evaluated, the numerical data indicated by expression 2, expression 4, ...

Expression 1, expression 2, expression 3, may contain a number or any expression which may result in a number.

The following example shows a dynamic variable display:

```
(ODW 1, 6, 33)
    ; Defines data window 1
(ODW 2, 14, 33)
    ; Defines data window 2
N10 (DW1=DATE, DW2=TIME)
    ; Displays the date in window 1 and the time in 2
(GOTO N10)
```

12.

PROGRAM CONTROL INSTRUCTIONS
Screen customizing instructions



**CNC 8055
CNC 8055i**

.T- MODEL
(SOFT V16.1x)

12.

The CNC allows displaying the data in decimal, hexadecimal and binary format; the following instructions are available:

(DW1 = 100)

Decimal format. Value "100" displayed in window 1.

(DWH2 = 100)

Hexadecimal format. Value "64" displayed in window 2.

(DWB3 = 100)

Binary format. Value "01100100" displayed in window 3.

When using the binary format, the display is limited to 8 digits in such a way that a value of "11111111" will be displayed for values greater than 255 and the value of "10000000" for values more negative than -127.

Besides, the CNC allows the number stored in one of the 26 data input variables (IB0-IB25) to be displayed in the requested window.

The following example shows a request and later displays the axis feedrate:

```
(ODW 3, 4, 60)
; Defines data window 3.
(IB1=INPUT "Axis feed: ", 5.4)
; Axis feedrate request.
(DW3=IB1)
; Displays feedrate in window 3.
```

(SK (expression 1) = "text1" (expression 2) = "text 2",)

The instruction SK defines and displays the new softkey menu indicated.

Each of the expressions will indicate the softkey number which it is required to modify (1-7, starting from the left) and the texts which it is required to write in them.

Expression 1, expression 2, expression 3, may contain a number or any expression which may result in a number.

Each text will allow a maximum of 20 characters that will be shown in two lines of 10 characters each. If the text selected has less than 10 characters, the CNC will center it on the top line, but if it has more than 10 characters the programmer will center it.

Examples:

(SK 1="HELP", SK 2="MAXIMUN POINT")

HELP	MAXIMUN POINT
------	------------------

(SK 1="FEED", SK 2=" __MAXIMUN__ __POINT")

FEED	MAXIMUN POINT
------	------------------



If while a standard CNC softkey menu is active, one or more softkeys are selected via high level language instruction: "SK", the CNC will clear all existing softkeys and it will only show the selected ones.

If while a user softkey menu is active, one or more softkeys are selected via high level language instruction "SK", the CNC will only replace the selected softkeys leaving the others intact.

(WKEY)

The mnemonic WKEY stops execution of the program until the key is pressed.

The pressed key will be recorded in the KEY variable.

```

...
( WKEY ) ; Wait for key
(IF KEY EQ $FC00 GOTO N1000) ; If key F1 has been pressed, continue
                               in N1000
...

```

12.

PROGRAM CONTROL INSTRUCTIONS
Screen customizing instructions

(WBUF "text", (expression))

The WBUF instruction can only be used when editing a program in the user channel.

This instruction may be programmed in two ways:

- (WBUF "text", (expression))

It adds the text and value of the expression, once it has been evaluated, to the block that is being edited and within the data entry window.

(Expression) may contain a number or any expression resulting in a number.

It will be optional to program the expression, but it will be required to define the text. If no text is required, "" must be programmed.

Examples for P100=10:

```

(WBUF "X", P100) => X10
(WBUF "X P100") => X P100

```

- (WBUF)

Enters into memory, adding to the program being edited and after the cursor position, the block being edited by means of (WBUF "text", (expression)). It also clears the editing buffer in order to edit a new block.

This allows the user to edit a complete program without having to quit the user editing mode after each block and press ENTER to "enter" it into memory.

```

(WBUF "(PCALL 25, ")
; Adds "(PCALL 25, " to the block being edited.
(IB1=INPUT "Parameter A:",-5.4)
; Request of Parameter A.
(WBUF "A=", IB1)
; Adds "A=(value entered)" to the block being edited.
(IB2=INPUT "Parameter B: ", -5.4)
; Request of Parameter B.
(WBUF ", B=", IB2)
; Adds "B=(value entered)" to the block being edited.
(WBUF ")")
; Adds ")" to the block being edited.
( WBUF )
; Enters the edited block into memory.
...

```

After executing this program the block being edited contains:

```
(PCALL 25, A=23.5, B=-2.25)
```

(SYSTEM)

The mnemonic SYSTEM stops execution of the user customized program and returns to the corresponding standard menu of the CNC.



**CNC 8055
CNC 8055i**

·T· MODEL
(SOFT V16.1X)

12.

Customizing program example:

The following customizing program must be selected as user program associated to the Editing Mode.

After selecting the Editing Mode and pressing the USER softkey, this program starts executing and it allows assisted editing of 2 user cycles. This editing process is carried out a cycle at a time and as often as desired.

Displays the initial editing page (screen)

N0 (PAGE 10)

Sets the softkeys to access the various modes and requests a choice

(SK 1="CYCLE 1",SK 2="CYCLE 2",SK 7="EXIT")

N5 (WKEY) ; Request a key
 (IF KEY EQ \$FC00 GOTO N10) ; Cycle 1
 (IF KEY EQ \$FC01 GOTO N20) ; Cycle 2
 (IF KEY EQ \$FC06 SYSTEM ELSE GOTO N5) ; Quit or request a key

CYCLE 1

; Displays page 11 and defines 2 data entry windows

N10 (PAGE 11)
 (ODW 1,10,60)
 (ODW 2,15,60)

;Editing

(WBUF "(PCALL 1, ") ; Adds "(PCALL 1," to the block being edited.
 (IB 1=INPUT "X:",-6.5) ; Requests the value of X.
 (DW 1=IB1) ; Data window 1 shows the entered value.
 (WBUF "X",IB1) ; Adds X (entered value) to the block being edited.
 (WBUF ",") ; Adds "," to the block being edited.
 (IB 2=INPUT "Y:",-6.5) ; Requests the value of Y.
 (DW 2=IB2) ; Data window 2 shows the entered value.
 (WBUF "Y",IB2) ; Adds Y (entered value) to the block being edited.
 (WBUF ")") ; Adds ")" to the block being edited.
 (WBUF) ; Enters the edited block into memory.
 ; For example : (PCALL 1, X2, Y3)
 (GOTO N0)



CNC 8055
CNC 8055i

.T- MODEL
(SOFT V16.1X)

CYCLE 2

; Displays page 12 and defines 3 data entry windows

N20 (PAGE 12)
 (ODW 1,10,60)
 (ODW 2,13,60)
 (ODW 3,16,60)

;Editing

(WBUF "(PCALL 2, ") ; Adds "(PCALL 2, " to the block being edited.

(IB 1=INPUT "A:",-6.5) ; Requests the value of A.
 (DW 1=IB1) ; Data window 1 shows the entered value.
 (WBUF "A",IB1) ; Adds A (entered value) to the block being edited.

(WBUF " , ") ; Adds " , " to the block being edited.

(IB 2=INPUT "B:",-6.5) ; Requests the value of B.
 (DW 2=IB2) ; Data window 2 shows the entered value.
 (WBUF "B",IB2) ; Adds B (entered value) to the block being edited.

(WBUF " , ") ; Adds " , " to the block being edited.

(IB 3=INPUT "C:",-6.5) ; Requests the value of C.
 (DW 3=IB3) ; Data window 3 shows the entered value.
 (WBUF "C",IB3) ; Adds C (entered value) to the block being edited.

(WBUF ") ") ; Adds ") " to the block being edited.

(WBUF) ; Enters the edited block into memory.
 For example: (PCALL 2, A3, B1, C3).

(GOTO N0)

12.

PROGRAM CONTROL INSTRUCTIONS
 Screen customizing instructions



**CNC 8055
 CNC 8055i**

.T- MODEL
 (SOFT V16.1X)

12.

PROGRAM CONTROL INSTRUCTIONS

Screen customizing instructions



CNC 8055
CNC 8055i

.T- MODEL
(SOFT V16.1X)

ANGULAR TRANSFORMATION OF AN INCLINE AXIS

13

With the angular transformation of an incline axis, it is possible to make movements along an axis that is not perpendicular to another. The movements are programmed in the Cartesian system and to make the movements, they are transformed into movements on the real axes.

On certain machines, the axes are configured in a Cartesian way, they are not perpendicular to each other. A typical case is the X axis of a lathe that for sturdiness reasons is not perpendicular to the Z axis.

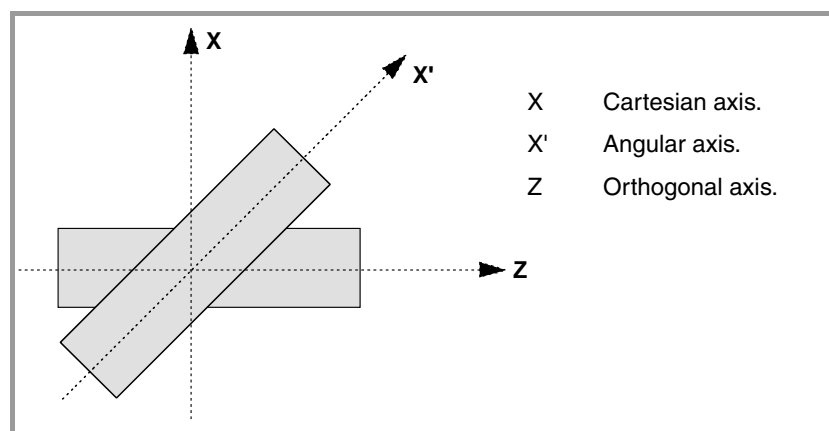

Programming in the Cartesian system (Z-X) requires activating an angular transformation of an incline plane that converts the movements of the real (non-perpendicular) axes (Z-X'). This way, a movement programmed on the X axis is transformed into movements on the Z-X' axes; i.e. it then moves along the Z axis and the angular X' axis.

Turning angular transformation on and off.

The CNC assumes no transformation on power-up; the angular transformations are activated via part-program using the instruction G46.

The angular transformations are turned off via part-program using function G46. Optionally, a transformation may be "frozen" (suspended) to move angular axis by programming in Cartesian coordinates.

Influence of the reset, turning the CNC off and of the M30.

The angular transformation of an incline axis stays active after a RESET, M30 and even after turning the CNC off and back on.



CNC 8055
CNC 8055i

·T· MODEL
(SOFT V16.1x)

13.

ANGULAR TRANSFORMATION OF AN INCLINE AXIS

Considerations for the angular transformation of an incline axis.

The axes involved in an angular transformation must be linear. Both axes may have Gantry axes associated with them, they may be slaved (coupled) or synchronized by PLC.

If the angular transformation is active, the coordinates displayed will be those of the Cartesian system. Otherwise, it will display the coordinates of the real axes.

The following operations are possible while the transformation is active:

- Zero offsets.
- Coordinate preset.
- Activate the C axis.
- Movements in continuous / incremental jog and handwheels.

Movements to hardstop are not possible while the transformation is active.

Home search

Function G46 is canceled when homing an axis that is involved in the angular transformation (machine parameters ANGAXNA and ORTAXNA). When homing the axes that are not involved in the angular axis transformation, function G46 stays active.

While searching home, only the real axes move.

Jogging and handwheel movements.

Either the real or the Cartesian axes may be jogged depending on how they've been set by the manufacturer. It is selected via PLC (MACHMOVE) and it may be available, for example, from a user key.



CNC 8055
CNC 8055i

.T- MODEL
(SOFT V16.1X)

13.1 Turning angular transformation on and off

Turn angular transformation on

When the transformation is on, the movements are programmed in the Cartesian system and to make the movements, the CNC transforms them into movements on the real axes. The coordinates displayed on the screen will be those of the Cartesian system.

The angular transformation is turned on using function G46 whose programming format is:

```
G46 S1
```

This instruction turns a "frozen" (suspended) transformation on again. See "[13.2 Freezing the angular transformation](#)" on page 276.

Turning the angular transformation off

If the transformation is off, the movements are programmed and executed in the system of the real axes. The coordinates displayed on the screen will be those of the real axes.

The angular transformation is turned off using function G46 whose programming format is:

```
G46 S0
```

```
G46
```

The angular transformation of an incline axis stays active after a RESET, M30 and even after turning the CNC off and back on.

13.

ANGULAR TRANSFORMATION OF AN INCLINE AXIS

Turning angular transformation on and off

FAGOR 

CNC 8055
CNC 8055i

·T· MODEL
(SOFT V16.1X)

13.2 Freezing the angular transformation

Freezing the angular transformation is a special way to make movements along the angular axis, but programming it in the Cartesian system. The angular transformation cannot be "frozen" (suspended) while jogging.

The angular transformation is "frozen" (suspended) using function G46 whose programming format is:

```
G46 S2
```

Programming movements after "freezing" the angular transformation.

If an angular transformation is "frozen" (suspended), only the coordinate of the angular axis must be programmed in the motion block. If the coordinate of the orthogonal axis is programmed, the movement is carried out according to the normal angular transformation.

Canceling the freezing of a transformation.

The "freezing" of an angular transformation is canceled after a reset or an M30. Turning the transformation on (G46 S1) also cancels the "freezing".

13.

ANGULAR TRANSFORMATION OF AN INCLINE AXIS
Freezing the angular transformation

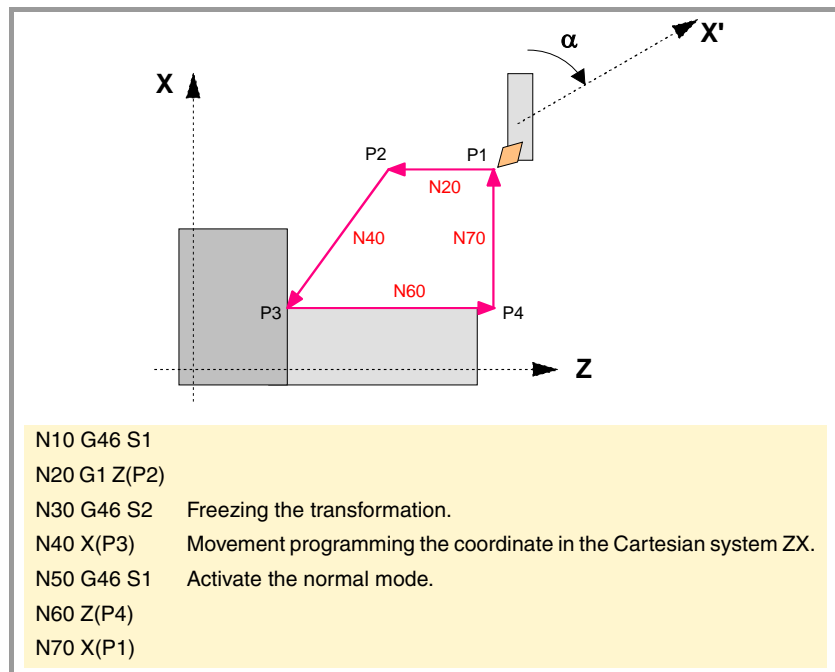

CNC 8055
CNC 8055i

.T- MODEL
(SOFT V16.1X)

APPENDIX

A.	ISO code programming	279
B.	Program control instructions.....	281
C.	Summary of internal CNC variables	285
D.	Key codes	293
E.	Programming assistance screens of the system.....	303
F.	Maintenance	307



CNC 8055
CNC 8055i

·T· MODEL
(SOFT V16.1X)

ISO CODE PROGRAMMING

Function	M	D	V	Meaning	Section
G00	*	?	*	Rapid traverse	6.1
G01	*	?	*	Linear interpolation	6.2
G02	*		*	Clockwise circular interpolation	6.3
G03	*		*	Counterclockwise circular interpolation	6.3
G04				Dwell/interruption of block preparation	7.1 / 7.2
G05	*	?	*	Round corner	7.3.2
G06			*	Circle center in absolute coordinates	6.4
G07	*	?		Square corner	7.3.1
G08			*	Arc tangent to previous path.	6.5
G09			*	Arc defined by three points	6.6
G10	*	*		Mirror image cancellation	7.5
G11	*		*	Mirror image on X axis	7.5
G12	*		*	Mirror image on Y axis	7.5
G13	*		*	Mirror image on Z axis	7.5
G14	*		*	Mirror image in the programmed directions	7.5
G15	*		*	"C" axis	6.15
G16	*		*	Main plane selection by two addresses	3.2
G17	*	?	*	Main plane X-Y and longitudinal Z	3.2
G18	*	?	*	Main plane Z-X and longitudinal Y	3.2
G19	*		*	Main plane Y-Z and longitudinal X	3.2
G20				Definition of lower work zone limits	3.8.1
G21				Definition of upper work zone limits.	3.8.1
G22			*	Enable/disable work zones.	3.8.2
G28	*		*	It selects the second spindle or toggles (swaps) axes	5.4 / 7.8
G29	*	*		It selects the main spindle or toggles (swaps) axes	5.4 / 7.8
G30	*		*	Spindle synchronization (offset)	5.5
G32	*		*	Feedrate "F" as an inverted function of time.	6.17
G33	*		*	Electronic threading	6.12
G34				Variable-pitch threading	6.14
G36			*	Controlled corner rounding	6.10
G37			*	Tangential entry	6.8
G38			*	Tangential exit	6.9
G39			*	Chamfer	6.11
G40	*	*		Cancellation of tool radius compensation	8.2.6
G41	*		*	Left-hand tool radius compensation	8.2.3
G41 N	*		*	Collision detection	8.3
G42	*		*	Right-hand tool radius compensation	8.2.3
G42 N	*		*	Collision detection	8.3
G45	*		*	Tangential control (G45)	6.18
G50	*		*	Controlled corner rounding	7.3.3
G51	*		*	Look-Ahead	7.4
G52			*	Movement until making contact	6.16
G53			*	Programming with respect to machine zero	4.3
G54	*		*	Absolute zero offset 1	4.4.2
G55	*		*	Absolute zero offset 2	4.4.2
G56	*		*	Absolute zero offset 3	4.4.2
G57	*		*	Absolute zero offset 4	4.4.2
G58	*		*	Additive zero offset 1	4.4.2
G59	*		*	Additive zero offset 2	4.4.2
G60			*	Face drilling / tapping canned cycle.	9.13
G61			*	Drilling / tapping canned cycle on the side of the part.	9.14
G62			*	Slot milling canned cycle on the side of the part	9.15
G63			*	Slot milling canned cycle on the face of the part	9.16
G66			*	Pattern repeat cycle canned cycle	9.1
G68			*	X axis roughing canned cycle	9.2
G69			*	Z axis roughing canned cycle	9.3

A.

APPENDIX
ISO code programming



CNC 8055
CNC 8055i

·T- MODEL
(SOFT V16.1x)

A.

APPENDIX
ISO code programming

Function	M	D	V	Meaning	Section
G70	*	?	*	Programming in inches	3.3
G71	*	?		Programming in millimeters	3.3
G72	*		*	General and specific scaling factor	7.6
G74			*	Home search	4.2
G75			*	Probing move until touching	10.1
G76			*	Probing move while touching	10.1
G77	*		*	Axis coupling (slaving)	7.7.1
G77S	*		*	Spindle synchronization	5.5
G78	*	*		Cancellation of axis coupling (slaving)	7.7.2
G78S	*	*		Cancellation of spindle synchronization	5.5
G81			*	Turning canned cycle for straight sections	9.4
G82			*	Facing canned cycle for straight sections	9.5
G83			*	Drilling canned cycle	9.6
G84			*	Turning canned cycle for curved sections	9.7
G85			*	Facing canned cycle for curved sections	9.8
G86			*	Longitudinal threading canned cycle	9.9
G87			*	Face threading canned cycle	9.10
G88			*	X axis grooving canned cycle	9.11
G89			*	Z axis grooving canned cycle	9.12
G90	*	?		Absolute programming:	3.4
G91	*	?	*	Incremental programming	3.4
G92				Coordinate preset / spindle speed limit	4.4.1
G93				Polar origin preset	4.5
G94	*	?		Feedrate in millimeters (inches) per minute	5.2.1
G95	*	?	*	Feedrate in millimeters (inches) per revolution.	5.2.2
G96	*		*	Constant surface speed	5.3.1
G97	*	*		Spindle speed in RPM	5.3.2
G145	*		*	Temporary cancellation of tangential control	6.19
G151	*	?		Programming the X axis in diameter.	3.5
G152	*	?		Programming the X axis in radius.	3.5

M means modal, i.e. the G function, once programmed, remains active while another incompatible G function is not programmed or until an M02, M30, EMERGENCY or RESET is executed or the CNC is turned off and back on.

D means BY DEFAULT, i.e. they will be assumed by the CNC when it is powered on, after executing M02, M30 or after EMERGENCY or RESET.

In those cases indicated by ? , it should be understood that the DEFAULT of these G functions depends on the setting of the general machine parameters of the CNC.

V means that the G code is displayed next to the current machining conditions in the execution and simulation modes.



CNC 8055
CNC 8055i

.T- MODEL
(SOFT V16.1x)

PROGRAM CONTROL INSTRUCTIONS

Display instructions.

(section 12.2)
(ERROR integer, "error text") Stops the execution of the program and displays the indicated error.
(MSG "message") Displays the indicated message.
(DGWZ expression 1, expression 4) Define the graphics area.

Enabling and disabling instructions.

(section 12.3)
(ESBLK and DSBLK) The CNC executes all the blocks between ESBLK and DSBLK as if it were a single block.
(ESTOP and DSTOP) Enabling (ESTOP) and disabling (DSTOP) of the Stop key and the external Stop signal (PLC).
(EFHOLD and DFHOLD) Enabling (EFHOLD) and disabling (DFHOLD) of the Feed-hold input (PLC).

Flow control instructions.

(section 12.4)
(GOTO N(expression)) It causes a jump within the same program, to the block defined by the label N(expression).
(RPT N(expression), N(expression), P(expression)) It repeats the execution of the portion of the program between the blocks defined by means of the labels N(expression).
(IF condition <action1> ELSE <action2>) It analyzes the given condition that must be a relational expression. If the condition is true (result equal to 1), <action1> will be executed, otherwise (result equal to 0) <action2> will be executed.

Subroutine instructions.

(section 12.5)
(SUB integer) Subroutine definition.
(RET) End of subroutine.
(CALL (expression)) Call to a subroutine.
(PCALL (expression), (assignment instruction), (assignment instruction),...) Call to a subroutine. In addition, using assignment instructions, it is possible to initialize up to a maximum of 26 local parameters of this subroutine.
(MCALL (expression), (assignment instruction), (assignment instruction),...) Same as the PCALL instruction, but making the indicated subroutine modal.
(MDOFF) Cancellation of modal subroutine.

B.

APPENDIX

Program control instructions



CNC 8055
CNC 8055i

·T· MODEL
(SOFT V16.1X)

Probe related instructions.

(section 12.6)
(PROBE (expression), (assignment instruction), (assignment instruction),...) It executes a probing canned cycle initializing its parameters by means of assignment instructions.

Interruption-subroutine instructions.

(section 12.7)
(REPOS X, Y, Z,) It must always be used inside an interruption subroutine and facilitates the repositioning of the machine axes to the point of interruption.

Program instructions.

(section 12.8)
(EXEC P(expression), (directory)) Starts program execution.
(MEXEC P(expression), (directory)) Starts program execution in modal mode.
(OPEN P(expression), (destination directory), A/D, "program comment") It begins editing a new program being possible to associate a comment with the program.
(WRITE <block text>) It adds, after the last block of the program which began to be edited by means of the mnemonic OPEN P, the information contained in <block text> as a new program block.

B.

APPENDIX
Program control instructions



CNC 8055
CNC 8055i

.T- MODEL
(SOFT V16.1x)

Screen customizing instructions.

(section 12.9)
(PAGE (expression)) The screen displays the indicated user page number (0-255) or system page (1000).
(SYMBOL (expression 1), (expression 2), (expression 3)) The screen displays the symbol (0-255) indicated by the expression 1. Its position on the screen is defined by expression 2 (row, 0-639) and by expression 3 (column 0-335).
(IB (expression) = INPUT "text", format) It displays the text indicated in the data input window and stores in the input variable (IBn) the data entered by the user.
(ODW (expression 1), (expression 2), (expression 3)) It defines and draws a white window on the screen (1 row and 14 columns). Its position on screen is defined by expression 2 (row) and by expression 3 (column).
(DW(expression 1) = (expression 2), DW (expression 3) = (expression 4), ...) It displays in the windows indicated by the value of the expression 1, 3,.., the numerical data indicated by the expression 2,4,..
(SK (expression 1) = "text1" (expression 2) = "text 2",) It defines and displays the new softkey menu indicated.
(WKEY) It stops the execution of the program until a key is pressed.
(WBUF "text", (expression)) It adds the text and value of the expression, once it has been evaluated, to the block that is being edited and within the data entry window.
(WBUF) Enters the block being edited into memory. It can only be used in the screen customizing program to be executed in the Editing mode.
(SYSTEM) It ends the execution of the user screen customizing program and returns to the corresponding standard menu of the CNC.

B.

APPENDIX
Program control instructions



CNC 8055
CNC 8055i

.T- MODEL
(SOFT V16.1X)

B.

APPENDIX

Program control instructions



CNC 8055
CNC 8055i

.T- MODEL
(SOFT V16.1X)

SUMMARY OF INTERNAL CNC VARIABLES

- The R symbol indicates that the variable can be read.
- The W symbol indicates that the variable can be modified.

Variables associated with tools.

Variable	CNC	PLC	DNC	(section 11.2.2)
TOOL	R	R	R	Number of the active tool.
TOD	R	R	R	Number of active tool offset.
NXTOOL	R	R	R	Number of the next requested tool waiting for M06.
NXTOD	R	R	R	Number of the next tool's offset.
TMZPn	R	R	-	(n) tool's position in the tool magazine.
TLFDn	R/W	R/W	-	(n) tool's offset number.
TLFFn	R/W	R/W	-	(n) tool's family code.
TLFNn	R/W	R/W	-	Nominal life assigned to tool (n).
TLFRn	R/W	R/W	-	Real life value of tool (n).
TMZTn	R/W	R/W	-	Contents of tool magazine position (n).
HTOR	R/W	R	R	Tool radius being used by the CNC to do the calculations.
TOXn	R/W	R/W	-	Tool length offset (n) along X axis.
TOZn	R/W	R/W	-	Tool length offset (n) along Z axis.
TOFn	R/W	R/W	-	Location code of offset (n).
TORn	R/W	R/W	-	Tool radius value of offset (n).
TOIn	R/W	R/W	-	Tool length wear of offset (n) along X axis.
TOKn	R/W	R/W	-	Tool length wear of offset (n) along Z axis.
NOSEAn:	R/W	R/W	-	Cutter angle of indicated tool.
NOSEWn	R/W	R/W	-	Width of indicated tool.
CUTAn	R/W	R/W	-	Cutting angle of indicated tool.

Variables associated with zero offsets.

Variable	CNC	PLC	DNC	(section 11.2.3)
ORG(X-C)	R	R	-	Active zero offset on the selected axis. The value of the additive offset indicated by the PLC is not included.
PORGF	R	-	R	Abscissa coordinate value of polar origin.
PORGS	R	-	R	Ordinate coordinate value of polar origin.
ORG(X-C)n	R/W	R/W	R	Zero offset (n) value of the selected axis.
PLCOF(X-C)	R/W	R/W	R	Value of the additive zero offset activated via PLC.
ADIOF(X-C)	R	R	R	Value for the selected axis of the zero offset with additive handwheel.

Variables associated with machine parameters.

Variable	CNC	PLC	DNC	(section 11.2.4)
MPGn	R	R	-	Value assigned to general machine parameter (n).
MP(X-C)n	R	R	-	Value assigned to (X-C) axis machine parameter (n).
MPSn	R	R	-	Value assigned to machine parameter (n) of the main spindle.
MPSSn	R	R	-	Value assigned to machine parameter (n) of the second spindle.
MPASn	R	R	-	Value assigned to machine parameter (n) of the auxiliary spindle.
MPLCn	R	R	-	Value assigned to machine parameter (n) of the PLC.



APPENDIX
Summary of internal CNC variables



CNC 8055
CNC 8055i

·T· MODEL
(SOFT V16.1x)

Variables associated with work zones.

Variable	CNC	PLC	DNC	(section 11.2.5)
FZONE	R	R/W	R	Status of work zone 1.
FZLO(X-C)	R	R/W	R	Work zone 1. Lower limit along the selected axis (X/C).
FZUP(X-C)	R	R/W	R	Work zone 1. Upper limit along the selected axis (X-C).
SZONE	R	R/W	R	Status of work zone 2.
SZLO(X-C)	R	R/W	R	Work zone 2. Lower limit along the selected axis (X/C).
SZUP(X-C)	R	R/W	R	Work zone 2. Upper limit along the selected axis (X-C).
TZONE	R	R/W	R	Status of work zone 3.
TZLO(X-C)	R	R/W	R	Work zone 3. Lower limit along the selected axis (X/C).
TZUP(X-C)	R	R/W	R	Work zone 3. Upper limit along the selected axis (X-C).
FOZONE	R	R/W	R	Status of work zone 4.
FOZLO(X-C)	R	R/W	R	Work zone 4. Lower limit along the selected axis (X/C).
FOZUP(X-C)	R	R/W	R	Work zone 4. Upper limit along the selected axis (X-C).
FIZONE	R	R/W	R	Status of work zone 5.
FIZLO(X-C)	R	R/W	R	Work zone 5. Lower limit along the selected axis (X/C).
FIZUP(X-C)	R	R/W	R	Work zone 5. Upper limit along the selected axis (X-C).

Feedrate related variables.

Variable	CNC	PLC	DNC	(section 11.2.6)
FREAL	R	R	R	Real feedrate of the CNC in mm/min or inch/min.
FREAL(X-C)	R	R	R	Actual (real) CNC feedrate of the selected axis.
FTEO(X-C)	R	R	R	Theoretical CNC feedrate of the selected axis.

Variables associated with function G94.

FEED	R	R	R	Active feedrate at the CNC in mm/min or inch/min.
DNCF	R	R	R/W	Feedrate selected via DNC.
PLCF	R	R/W	R	Feedrate selected via PLC.
PRGF	R	R	R	Feedrate selected by program.

Variables associated with function G95.

FPREV	R	R	R	Active feedrate at CNC, in m/rev or inch/rev.
DNCFPR	R	R	R/W	Feedrate selected via DNC.
PLCFPR	R	R/W	R	Feedrate selected via PLC.
PRGFPR	R	R	R	Feedrate selected by program.

Variables associated with function G32.

PRGFIN	R	R	R	Feedrate selected by program, in 1/min.
--------	---	---	---	---

Variables associated with feedrate override (%)

FRO	R	R	R	Feedrate Override (%) active at the CNC.
PRGFRO	R/W	R	R	Override (%) selected by program.
DNCFRO	R	R	R/W	Override (%) selected via DNC.
PLCFRO	R	R/W	R	Override (%) selected via PLC.
CNCFRO	R	R	R	Override (%) selected from the front panel knob.
PLCCFR	R	R/W	R	Override (%) of the PLC execution channel.

Coordinate related variables.

Variable	CNC	PLC	DNC	(section 11.2.7)
PPOS(X-C)	R	-	-	Programmed theoretical position value (coordinate).
POS(X-C)	R	R	R	Machine coordinates. Real coordinates of the tool base.
TPOS(X-C)	R	R	R	Machine coordinates. Theoretical coordinates of the tool base.
APOS(X-C)	R	R	R	Part coordinates. Real coordinates of the tool base.
ATPOS(X-C)	R	R	R	Part coordinates. Theoretical coordinates of the tool base.
FLWE(X-C)	R	R	R	Following error of the indicated axis.
DIST(X-C)	R/W	R/W	R	Distance traveled by the indicated axis.
LIMPL(X-C)	R/W	R/W	R	Second upper travel limit.
LIMMI(X-C)	R/W	R/W	R	Second lower travel limit.
DPLY(X-C)	R	R	R	Coordinate of the selected axis displayed on the screen.
DRPO(X-C)	R	R	R	Position indicated by the Sercos drive of the selected axis.
GPOS(X-C)n p	R	-	-	Coordinate of the selected axis, programmed in the (n) block of the program (p).



APPENDIX
Summary of internal CNC variables



CNC 8055
CNC 8055i

.T- MODEL
(SOFT V16.1X)

Variables associated with electronic handwheels.

Variable	CNC	PLC	DNC	(section 11.2.8)
HANPF	R	R	-	Pulses received from 1st handwheel since the CNC was turned on.
HANPS	R	R	-	Pulses received from 2nd handwheel since the CNC was turned on.
HANPT	R	R	-	Pulses received from 3rd handwheel since the CNC was turned on.
HANPFO	R	R	-	Pulses received from 4th handwheel since the CNC was turned on.
HANDSE	R	R		For handwheels with a selector button, it indicates whether that button has been pressed or not.
HANFCT	R	R/W	R	Multiplying factor different for each handwheel (when having several).
HBEVAR	R	R/W	R	HBE handwheel. Reading enabled, axis being jogged and multiplying factor (x1, x10, x100).
MASLAN	R/W	R/W	R/W	Linear path angle for "Path handwheel" or "Path Jog" mode.
MASCFI	R/W	R/W	R/W	Arc center coordinates for "Path handwheel mode" or "Path jog".
MASCSE	R/W	R/W	R/W	Arc center coordinates for "Path handwheel mode" or "Path jog".

Feedback related variables.

Variable	CNC	PLC	DNC	(section 11.2.9)
ASIN(X-C)	R	R	R	A signal of the CNC's sinusoidal feedback for the selected axis.
BSIN(X-C)	R	R	R	B signal of the CNC's sinusoidal feedback for the selected axis.
ASINS	R	R	R	"A" signal of the CNC's sinusoidal feedback for the spindle.
BSINS	R	R	R	"B" signal of the CNC's sinusoidal feedback for the spindle.
SASINS	R	R	R	"A" signal of the CNC sinusoidal feedback for the second spindle.
SBSINS	R	R	R	"B" signal of the CNC sinusoidal feedback for the second spindle.

Variables associated with the main spindle.

Variable	CNC	PLC	DNC	(section 11.2.10)
SREAL	R	R	R	Real spindle speed
FTEOS	R	R	R	Theoretical spindle speed.

Variables associated with spindle speed.

SPEED	R	R	R	Active spindle speed at the CNC.
DNCS	R	R	R/W	Spindle speed selected via DNC.
PLCS	R	R/W	R	Spindle speed selected via PLC.
PRGS	R	R	R	Spindle speed selected by program.

Variables associated with constant surface speed.

CSS	R	R	R	Constant surface speed active at the CNC.
DNCCSS	R	R	R/W	Constant surface speed selected via DNC.
PLCCSS	R	R/W	R	Constant surface speed selected via PLC.
PRGCSS	R	R	R	Constant surface speed selected by program.

Variables associated with the spindle override.

SSO	R	R	R	Spindle Speed Override (%) active at the CNC.
PRGSSO	R/W	R	R	Override (%) selected by program.
DNCSSO	R	R	R/W	Override (%) selected via DNC.
PLCSSO	R	R/W	R	Override (%) selected via PLC.
CNCSSO	R	R	R	Spindle Speed Override (%) selected from front panel.

Speed limit related variables.

SLIMIT	R	R	R	Spindle speed limit active at the CNC.
DNCSL	R	R	R/W	Spindle speed limit selected via DNC.
PLCSL	R	R/W	R	Spindle speed limit selected via PLC.
PRGSL	R	R	R	Spindle speed limit selected by program.
MDISL	R	R/W	R	Maximum machining spindle speed.



CNC 8055
CNC 8055i

.T- MODEL
(SOFT V16.1x)



Position related variables.

POSS	R	R	R	Real Spindle position. Reading from the PLC in ten-thousandths of a degree (within ±999999999) and from the CNC in degrees (within ±99999.9999).
RPOSS	R	R	R	Real Spindle position. Reading from the PLC in ten-thousandths of a degree (between 0 and 3600000) and from the CNC in degrees (between 0 and 360).
TPOSS	R	R	R	Theoretical spindle position. Reading from the PLC in ten-thousandths of a degree (within ±999999999) and from the CNC in degrees (within ±99999.9999).
RTPOSS	R	R	R	Theoretical spindle position. Reading from the PLC in ten-thousandths of a degree (between 0 and 3600000) and from the CNC in degrees (between 0 and 360).
DRPOS	R	R	R	Position indicated by the Sercos drive.
PRGSP	R	R	R	Position programmed in M19 via program for the main spindle.

Variables related to the following error.

FLWES	R	R	R	Spindle following error.
SYNCER	R	R	R	Error of second spindle (synchronized) following the main spindle.

Variables associated with the second spindle.

Variable	CNC	PLC	DNC	(section 11.2.11)
SSREAL	R	R	R	Real spindle speed
SFTEOS	R	R	R	Theoretical spindle speed.

Variables associated with spindle speed.

SSPEED	R	R	R	Active spindle speed at the CNC.
SDNCS	R	R	R/W	Spindle speed selected via DNC.
SPLCS	R	R/W	R	Spindle speed selected via PLC.
SPRGS	R	R	R	Spindle speed selected by program.

Variables associated with constant surface speed.

SCSS	R	R	R	Constant surface speed active at the CNC.
SDNCCS	R	R	R/W	Constant surface speed selected via DNC.
SPLCCS	R	R/W	R	Constant surface speed selected via PLC.
SPRGS	R	R	R	Constant surface speed selected by program.

Variables associated with the spindle override.

SSSO	R	R	R	Spindle Speed Override (%) active at the CNC.
SPRGSO	R/W	R	R	Override (%) selected by program.
SDNCSCO	R	R	R/W	Override (%) selected via DNC.
SPLCSO	R	R/W	R	Override (%) selected via PLC.
SCNCSO	R	R	R	Spindle Speed Override (%) selected from front panel.

Speed limit related variables.

SSLIMI	R	R	R	Spindle speed limit active at the CNC.
SDNCSL	R	R	R/W	Spindle speed limit selected via DNC.
SPLCSL	R	R/W	R	Spindle speed limit selected via PLC.
SPRGS	R	R	R	Spindle speed limit selected by program.



CNC 8055
CNC 8055i

.T- MODEL
(SOFT V16.1x)

Position related variables.

SPOSS	R	R	R	Real Spindle position. Reading from the PLC in ten-thousandths of a degree (within ±999999999) and from the CNC in degrees (within ±99999.9999).
SRPOSS	R	R	R	Real Spindle position. Reading from the PLC in ten-thousandths of a degree (between 0 and 3600000) and from the CNC in degrees (between 0 and 360).
STPOSS	R	R	R	Theoretical spindle position. Reading from the PLC in ten-thousandths of a degree (within ±999999999) and from the CNC in degrees (within ±99999.9999).
SRTPOS	R	R	R	Theoretical spindle position. Reading from the PLC in ten-thousandths of a degree (between 0 and 3600000) and from the CNC in degrees (between 0 and 360).
SDRPOS	R	R	R	Position indicated by the Sercos drive.
SPRGSP	R	R	R	Position programmed in M19 via program for the second spindle.

Variables related to the following error.

SFLWES	R	R	R	Spindle following error.
--------	---	---	---	--------------------------

Variables associated with the live tool.

Variable	CNC	PLC	DNC	(section 11.2.12)
ASPROG	R	R	-	Speed programmed in M45 S (within the associated subroutine).
LIVRPM	R	R	-	Speed of the live tool in TC mode.

PLC related variables.

Variable	CNC	PLC	DNC	(section 11.2.13)
PLCMMSG	R	-	R	Number of the active PLC message with the highest priority.
PLCIn	R/W	-	-	32 PLC inputs starting from (n).
PLCO _n	R/W	-	-	32 PLC outputs starting from (n).
PLCM _n	R/W	-	-	32 PLC marks starting from (n).
PLCR _n	R/W	-	-	(n) Register.
PLCT _n	R/W	-	-	Indicated (n) Timer's count.
PLCC _n	R/W	-	-	Indicated (n) Counter's count.
PLCMM _n	R/W	-	-	Modifies the (n) mark of the PLC.

Variables associated with local and global parameters.

Variable	CNC	PLC	DNC	(section 11.2.14)
GUP n	-	R/W	-	Global parameter (P100-P299) (n).
LUP (a,b)	-	R/W	-	Indicated local (P0-P25) parameter (b) of the nesting level (a).
CALLP	R	-	-	Indicates which local parameters have been defined by means of a PCALL or MCALL instruction (calling a subroutine).

Sercos variables.

Variable	CNC	PLC	DNC	(section 11.2.15)
SETGE(X-C)	W	W	-	Gear ratio and parameter set of the (X-C) axis drive
SETGES	W	W	-	Gear ratio and parameter set of the main spindle
SSETGS	W	W	-	Gear ratio and parameter set of the second spindle
SVAR(X-C) id	R/W	-	-	Sercos variable sercos for the (X-C) axis "id"
SVARS id	R/W	-	-	Sercos variable sercos for the main spindle "id"
SSVARS id	R/W	-	-	Sercos variable sercos for the second spindle "id"
TSVAR(X-C) id	R	-	-	Third attribute of the sercos variable for the (X-C) axis "id"
TSVARS id	R	-	-	Third attribute of the sercos variable for the main spindle "id"
TSSVAR id	R	-	-	Third attribute of the sercos variable for the second spindle "id"



APPENDIX
Summary of internal CNC variables



CNC 8055
CNC 8055i

·T· MODEL
(SOFT V16.1X)

Software & hardware configuration variables.

Variable	CNC	PLC	DNC	(section 11.2.16)
HARCON	R	R	R	It indicates, with bits, the CNC's hardware configuration.
HARCOA	R	R	R	It indicates, with bits, the CNC's hardware configuration.
IDHARH	R	R	R	Hardware identifier (8 least significant bits).
IDHARL	R	R	R	Hardware identifier (4 most significant bits).
SOFCON	R	R	R	Software version of the CNC (bits 15-0) and HD (bits 31-16)
HDMEGA	R	R	R	Hard disk size (in megabytes).
KEYIDE	R	R	R	Keyboard code, according to the auto-identification system.

Variables associated with telediagnosis.

Variable	CNC	PLC	DNC	(section 11.2.17)
HARSWA	R	R	R	Hardware configuration.
HARSWB	R	R	R	Hardware configuration.
HARTST	R	R	R	Hardware test.
MEMTST	R	R	R	Memory test.
NODE	R	R	R	Node number in the Sercos ring.
VCHECK	R	R	R	Software version checksum.
IONODE	R	R	R	Position of the "ADDRESS" switch of the I/O CAN bus.
IOSLOC	R	R	R	Number of local I/O available.
IOSREM	R	R	R	Number of remote I/O available.

Operating-mode related variables.

Variable	CNC	PLC	DNC	(section 11.2.18)
OPMODE	R	R	R	Operating mode.
OPMODA	R	R	R	Operating mode when working in the main channel.
OPMODB	R	R	R	Type of simulation.
OPMODC	R	R	R	Axes selected by handwheel.

Other variables.

Variable	CNC	PLC	DNC	(section 11.2.19)
NBTOOL	R	-	R	Number of the tool being managed..
PRGN	R	R	R	Number of the program in execution.
BLKN	R	R	R	Label number of the last executed block.
GSn	R	-	-	Status of the indicated G function (n).
GGSA	-	R	R	Status of functions G00 thru G24.
GGSB	-	R	R	Status of functions G25 thru G49.
GGSC	-	R	R	Status of functions G50 thru G74.
GGSD	-	R	R	Status of functions G75 thru G99.
MSn	R	-	-	Status of the indicated M function (n)
GMS	-	-	R	Status of M functions: M (0..6, 8, 9, 19, 30, 41..44).
PLANE	R	R	R	Abscissa and ordinate axes of the active plane.
LONGAX	R	R	R	Axis affected by the tool length compensation (G15).
MIRROR	R	R	R	Active mirror images.
SCALE	R	R	R	General scaling factor applied. Reading from the PLC in ten-thousandths.
SCALE(X-C)	R	R	R	Scaling Factor applied only to the indicated axis. Reading from the PLC in ten-thousandths.
ORGROT	R	R	R	Rotation angle (G73) of the coordinate system.
PRBST	R	R	R	Returns probe status.
CLOCK	R	R	R	System clock in seconds.
TIME	R	R	R/W	Time in Hours, minutes and seconds.
DATE	R	R	R/W	Date in Year-Month-Day format
TIMER	R/W	R/W	R/W	Clock activated by PLC, in seconds.
CYTIME	R	R	R	Time to execute a part in hundredths of a second.
PARTC	R/W	R/W	R/W	Parts counter of the CNC.
FIRST	R	R	R	First time a program is executed.
KEY	R/W	R/W	R/W	keystroke code.
KEYSRC	R/W	R/W	R/W	Source of the keys.
ANAI _n	R	R	R	Voltage (in volts) of the indicated analog input (n).
ANAO _n	R/W	R/W	R/W	Voltage (in volts) to apply to the indicated output (n).
CNCERR	-	R	R	Active CNC error number.



APPENDIX
Summary of internal CNC variables



CNC 8055
CNC 8055i

.T- MODEL
(SOFT V16.1X)

Variable	CNC	PLC	DNC	(section 11.2.19)
PLCERR	-	-	R	Active PLC error number.
DNCERR	-	R	-	Number of the error generated during DNC communications.
AXICOM	R	R	R	Pairs of axes switched with function G28.
TANGAN	R	R	R	Angular position with respect to the path (G45).
TPIOUT(X-C)	R	R	R	Output of the PI of the tandem master axis in rpm.
DNCSTA	-	R	-	DNC transmission status.
TIMEG	R	R	R	Remaining time to finish the dwell block (in hundredths of a second)..
SELPRO	R/W	R/W	R	When having two probe inputs, it selects the active input.
DIAM	R/W	R/W	R	It changes the programming mode for X axis coordinates between radius and diameter.
PRBMOD	R/W	R/W	R	Indicates whether a probing error must be displayed or not.
RIP	R	R	R	Linear theoretical feedrate resulting from the next loop (in mm/min).
TEMPI _n	R	R	R	It returns the temperature in tenths of a degree detected by the PT100.
TIPPRB	R	R	R	PROBE cycle being executed.
PANEDI	R	R	R	WINDRAW55 application. Number of screen being executed.
DATEDI	R	R	R	WINDRAW55 application. Number of element (item) being executed.



*The "KEY" variable can be "written" at the CNC only via the user channel.
The "NBTOOL" variable can only be used within the tool change subroutine.*

C.

APPENDIX
Summary of internal CNC variables



CNC 8055
CNC 8055i

.T- MODEL
(SOFT V16.1x)

C.

APPENDIX

Summary of internal CNC variables



CNC 8055
CNC 8055i

.T- MODEL
(SOFT V16.1X)

KEY CODES

Alpha-numeric keyboard and monitor

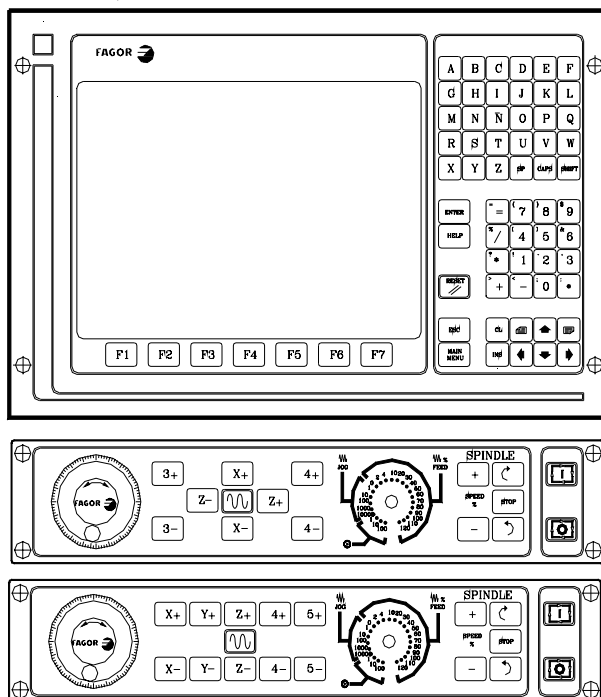
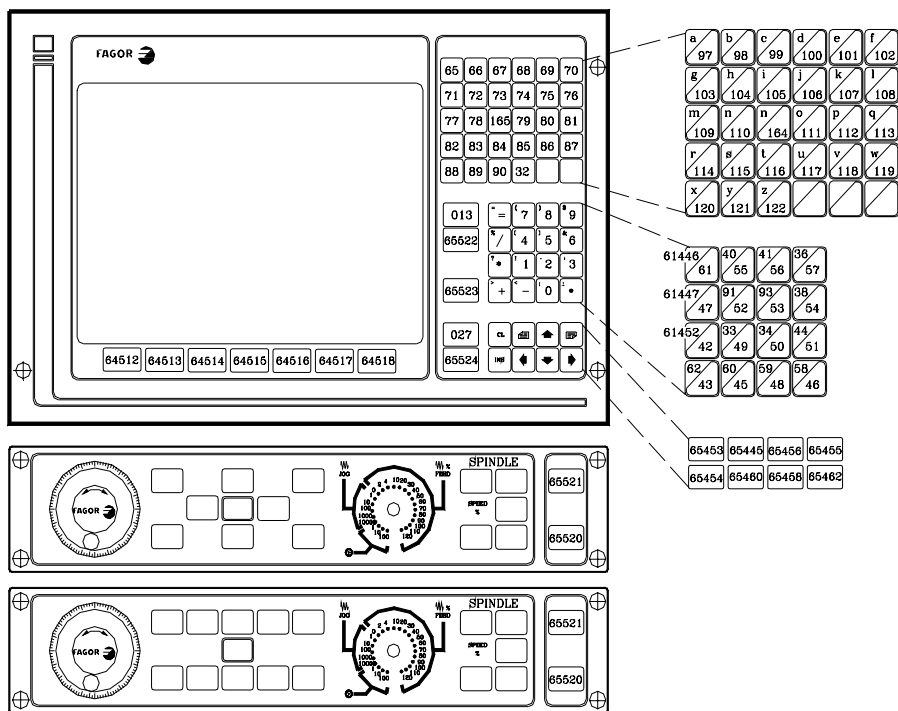

D.

APPENDIX Key codes



CNC 8055
CNC 8055i

·T- MODEL
(SOFT V16.1X)

D.
APPENDIX
 Key codes

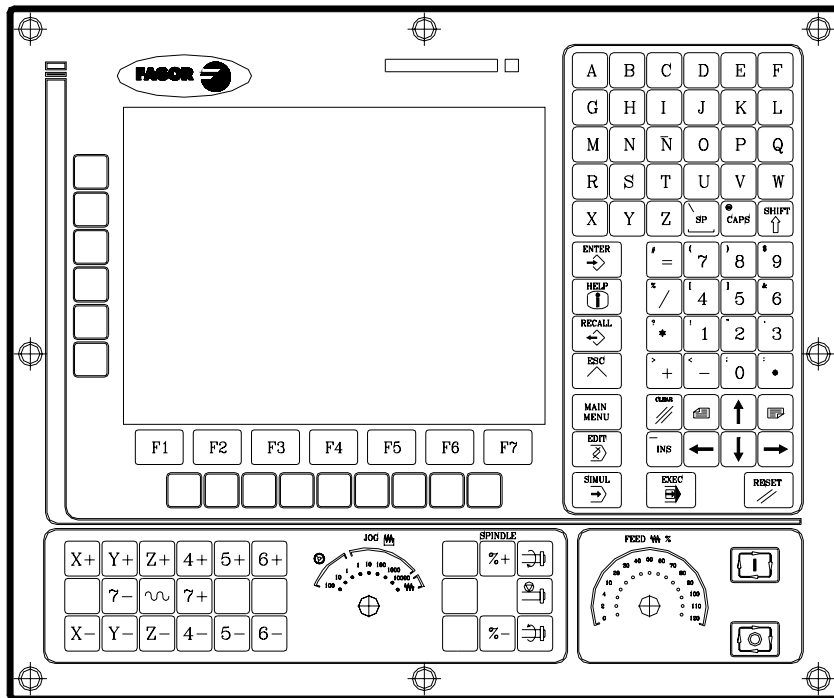
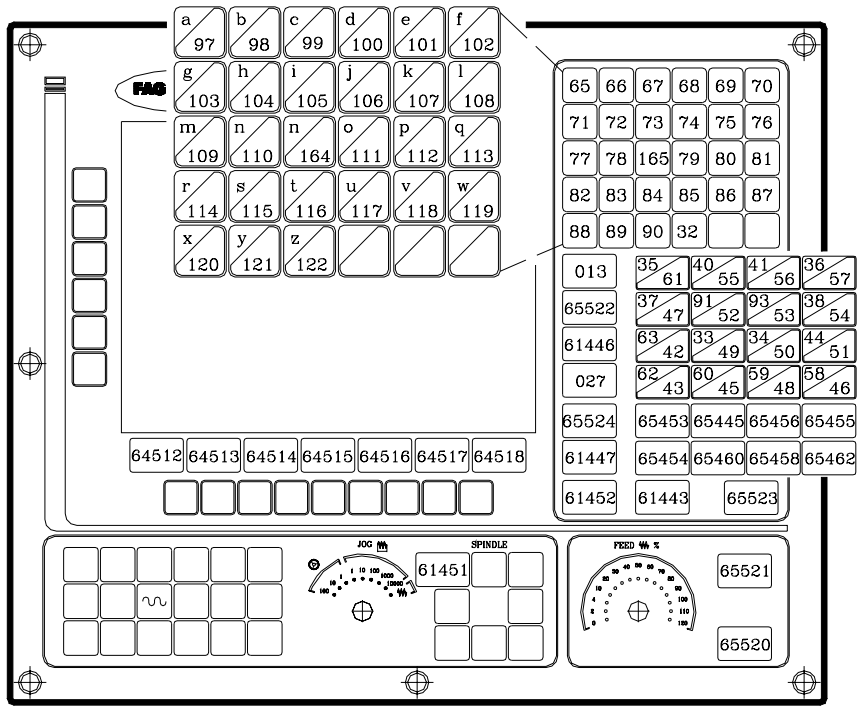

CNC 8055
 CNC 8055i

.T- MODEL
 (SOFT V16.1x)

Alphanumeric operator panel

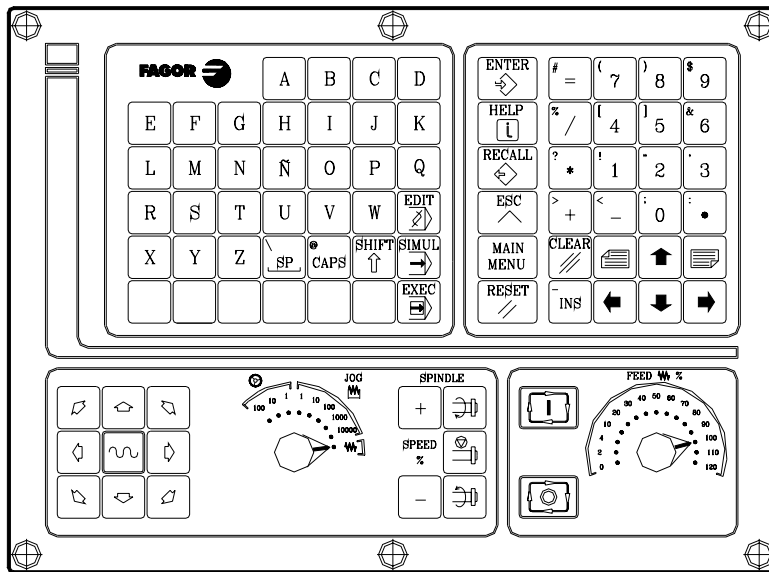
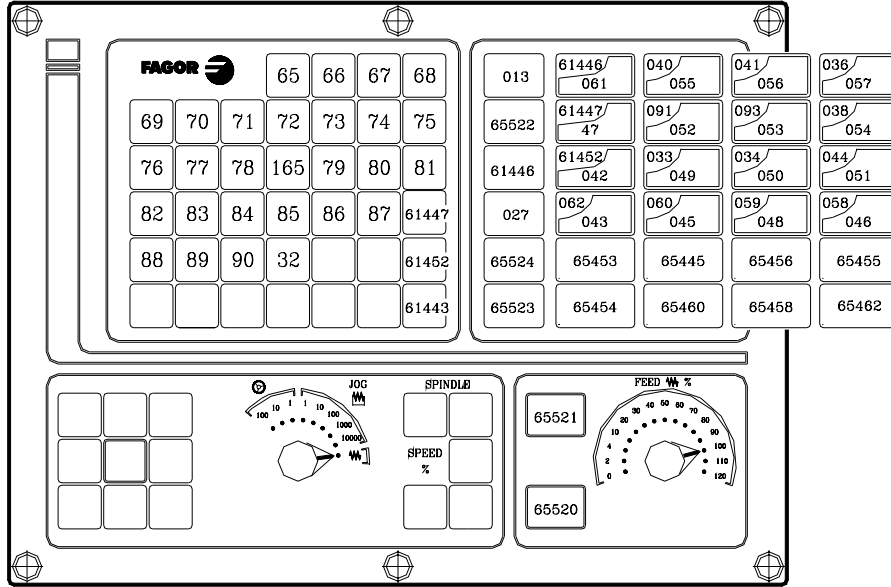

D.

APPENDIX
Key codes



CNC 8055
CNC 8055i

· T- MODEL
(SOFT V16.1x)

TC operator panel

D.
APPENDIX
Key codes

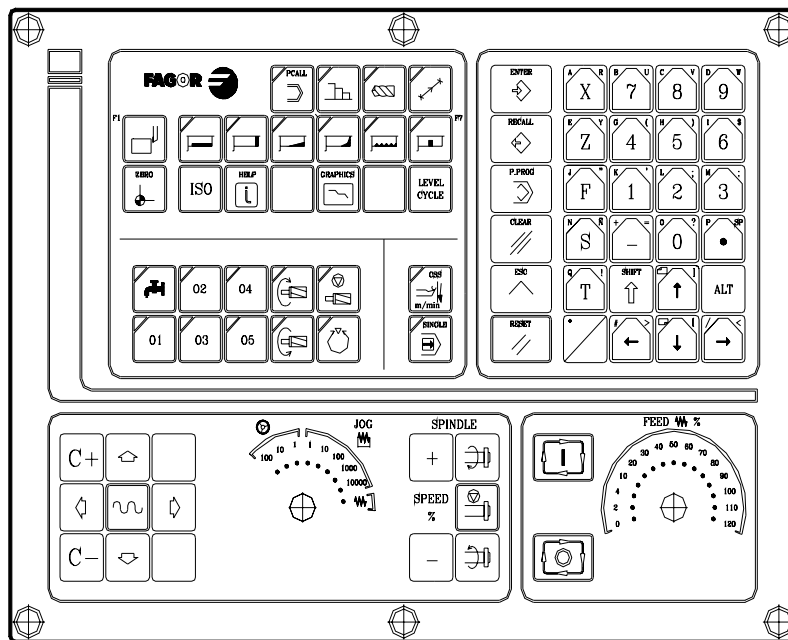
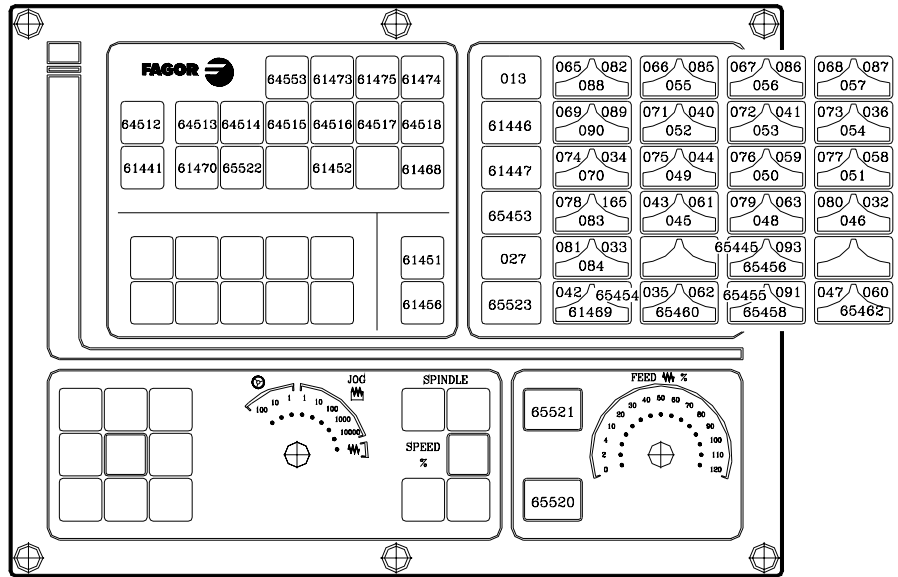

CNC 8055
CNC 8055i

.T- MODEL
(SOFT V16.1x)

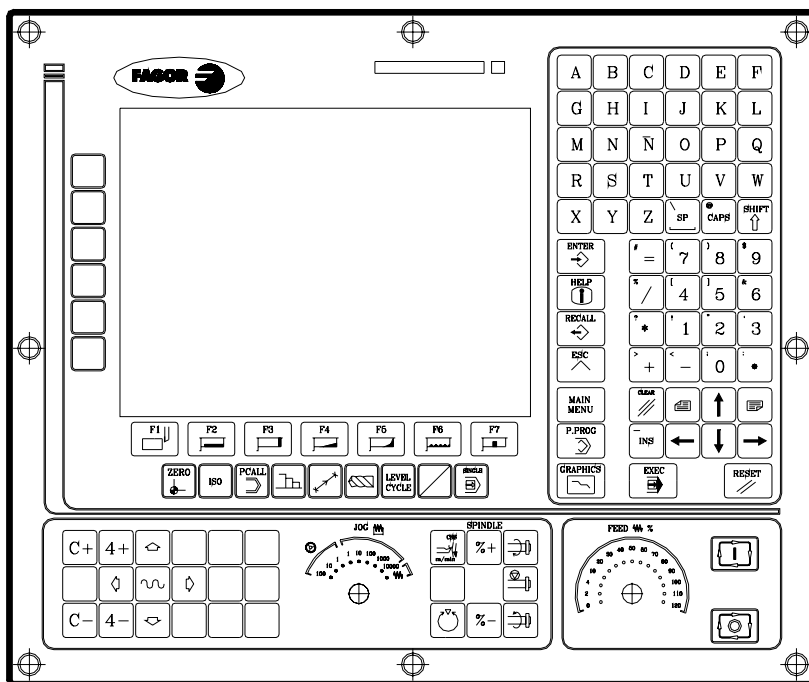
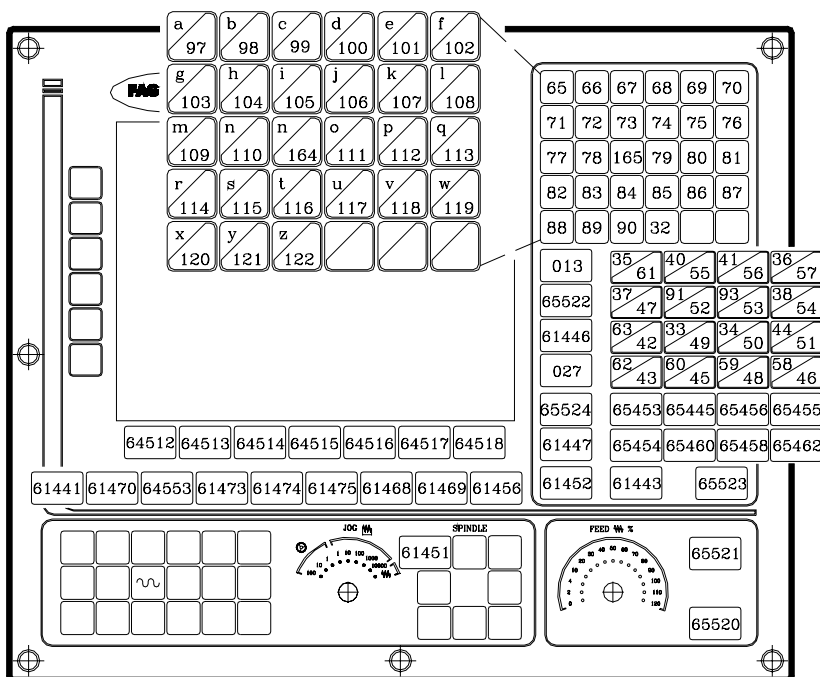

D.
APPENDIX
Key codes



CNC 8055
CNC 8055i

·T· MODEL
(SOFT V16.1x)

D.
APPENDIX
Key codes

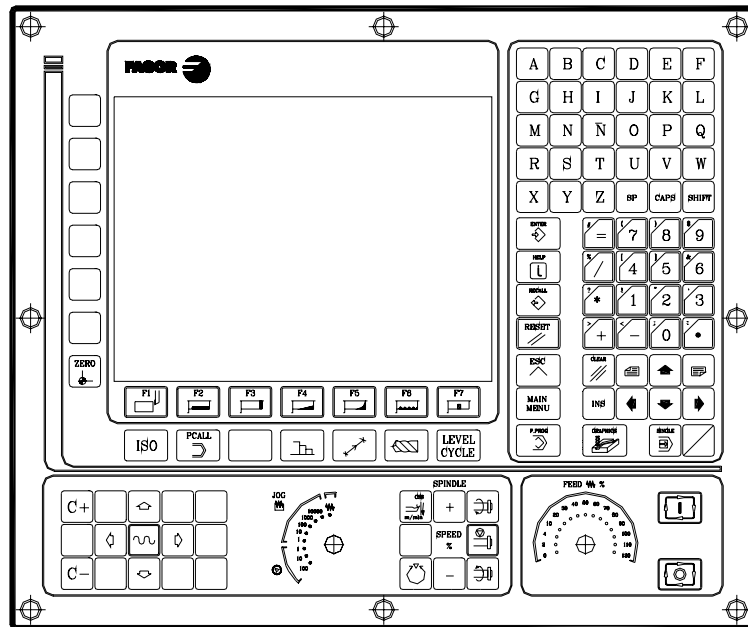
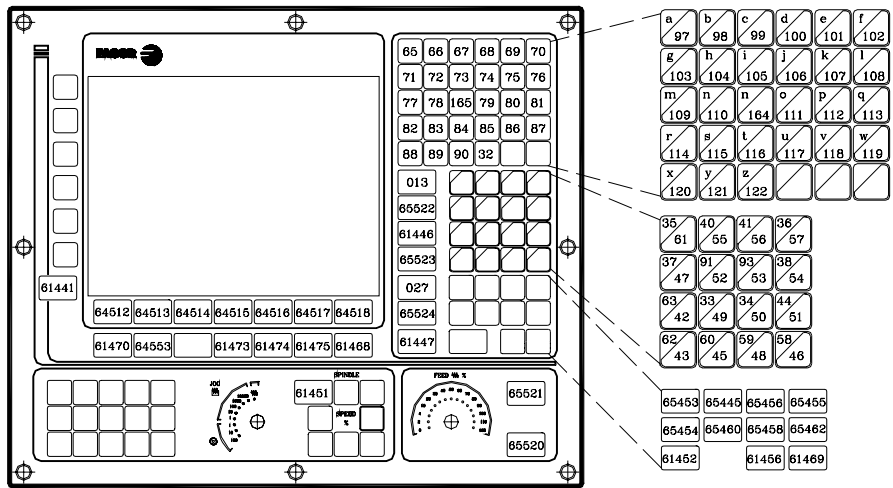

CNC 8055
CNC 8055i

.T- MODEL
(SOFT V16.1x)

MCO/TCO operator panel

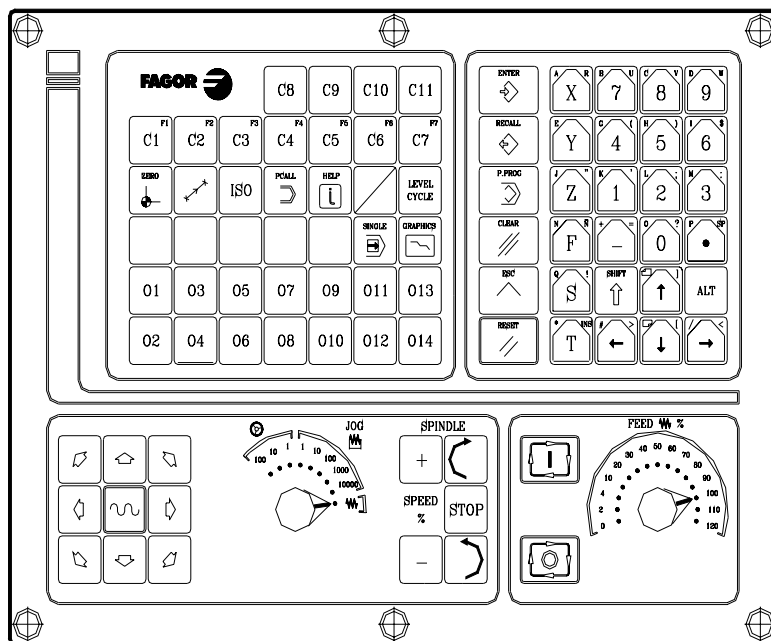
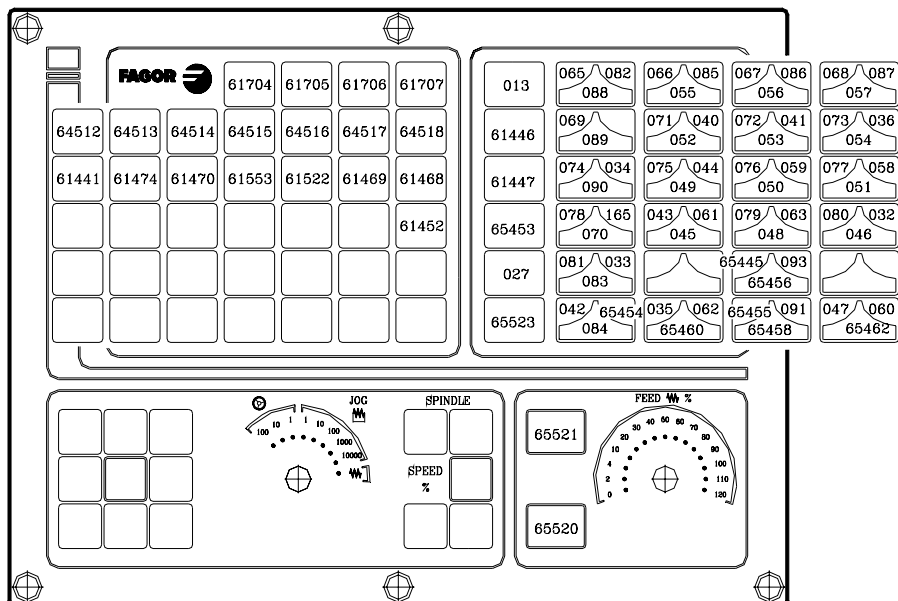

D.
APPENDIX
Key codes



CNC 8055
CNC 8055i

·T· MODEL
(SOFT V16.1x)

Alphanumeric keyboard

D.
APPENDIX
Key codes

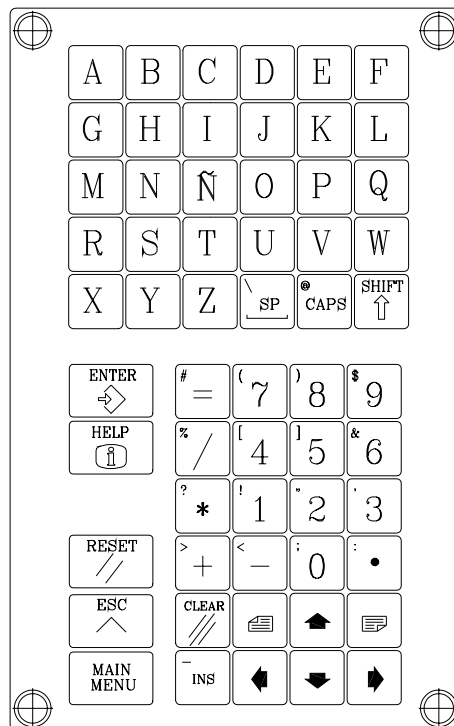
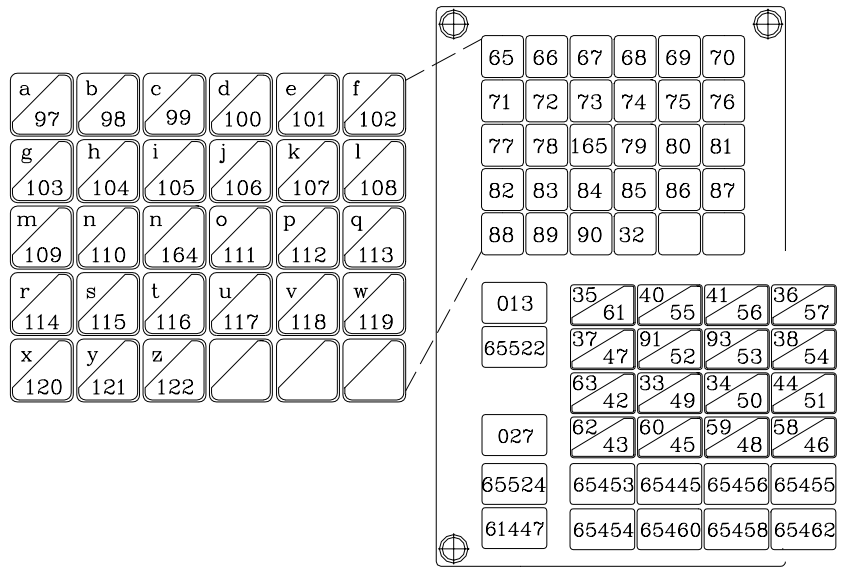

CNC 8055
CNC 8055i

.T- MODEL
(SOFT V16.1x)

11" LCD Monitor

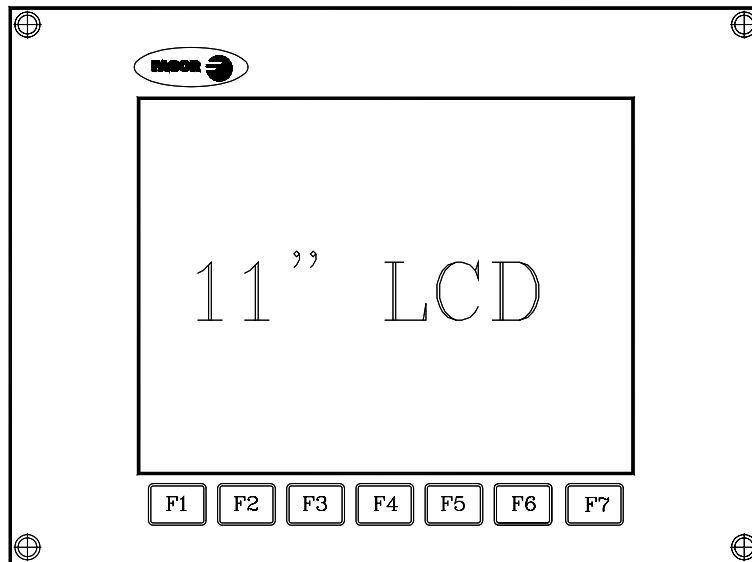
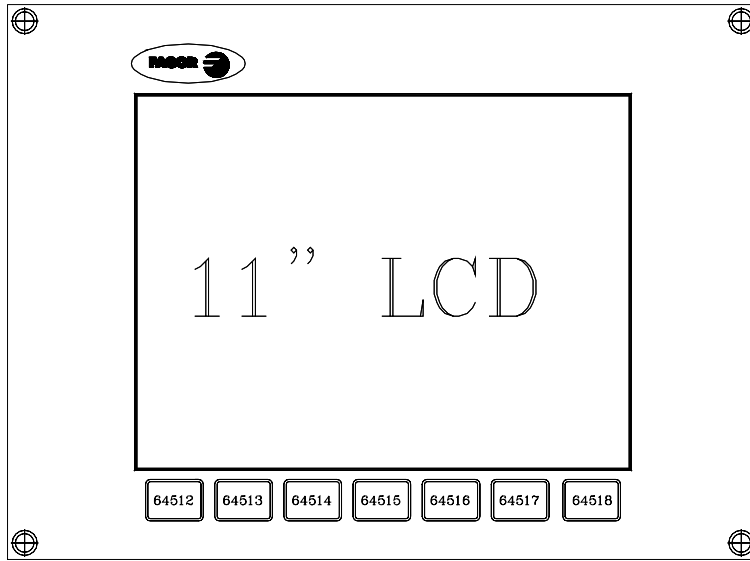

D.

APPENDIX
Key codes



CNC 8055
CNC 8055i

·T· MODEL
(SOFT V16.1X)

D.

APPENDIX
Key codes



CNC 8055
CNC 8055i

.T- MODEL
(SOFT V16.1X)

PROGRAMMING ASSISTANCE SCREENS OF THE SYSTEM

These screens (pages) may be displayed using the high level instruction "PAGE". They all belong to the CNC system and are used as help screens of the corresponding functions.

Syntax-graphics help screens

Page 1000	Preparatory functions G00-G09.
Page 1001	Preparatory functions G10-G19.
Page 1002	Preparatory functions G20-G44.
Page 1003	Preparatory functions G53-G59.
Page 1004	Preparatory functions G60-G69.
Page 1005	Preparatory functions G70-G79.
Page 1006	Preparatory functions G80-G89.
Page 1007	Preparatory functions G90-G99.
Page 1008	Auxiliary (miscellaneous) M functions.
Page 1009	Auxiliary (miscellaneous) M functions with the "next page" symbol.
Page 1010	Same as number 250 of the directory if there is one.
Page 1011	Same as number 251 of the directory if there is one.
Page 1012	Same as number 252 of the directory if there is one.
Page 1013	Same as number 253 of the directory if there is one.
Page 1014	Same as number 254 of the directory if there is one.
Page 1015	Same as number 255 of the directory if there is one.
Page 1016	High level language dictionary (from A to G).
Page 1017	High level language dictionary (from H to N).
Page 1018	High level language dictionary (from O to S).
Page 1019	High level language dictionary (from T to Z).
Page 1020	Variables that may be accessed through high level language (part 1).
Page 1021	Variables that may be accessed through high level language (part 2).
Page 1022	Variables that may be accessed through high level language (part 3).
Page 1023	Variables that may be accessed through high level language (part 4).
Page 1024	Variables that may be accessed through high level language (part 5).
Page 1025	Variables that may be accessed through high level language (part 6).
Page 1026	Variables that may be accessed through high level language (part 7).
Page 1027	Variables that may be accessed through high level language (part 8).
Page 1028	Variables that may be accessed through high level language (part 9).
Page 1029	Variables that may be accessed through high level language (part 10).
Page 1030	Variables that may be accessed through high level language (part 11).

E.

APPENDIX

Programming assistance screens of the system

FAGOR 

**CNC 8055
CNC 8055i**

.T- MODEL
(SOFT V16.1X)

E.

APPENDIX
Programming assistance screens of the system

Page 1031	Variables that may be accessed through high level language (part 12).
Page 1032	Mathematical operators.

Syntax help: ISO language

Page 1033	Structure of a program block.
Page 1034	Positioning and linear interpolation: G00, G01 (part 1).
Page 1035	Positioning and linear interpolation: G00, G01 (part 2).
Page 1036	Circular interpolation: G02, G03 (part 1).
Page 1037	Circular interpolation: G02, G03 (part 2).
Page 1038	Circular interpolation: G02, G03 (part 3).
Page 1039	Circular tangent path: G08 (part 1).
Page 1040	Circular tangent path: G08 (part 2).
Page 1041	Circular path through 3 points: G09 (part 1).
Page 1042	Circular path through 3 points: G09 (part 2).
Page 1043	Electronic threading: G33.
Page 1044	Rounding: G36.
Page 1045	Tangential entry: G37.
Page 1046	Tangential exit: G38.
Page 1047	Chamfer: G39.
Page 1048	Dwell/interruption of block preparation: G04, G04K.
Page 1049	Square/round corner: G07, G05.
Page 1050	Mirror image: G11, G12, G13, G14.
Page 1051	Programming of planes and longitudinal axis. G16, G17, G18, G19, G15.
Page 1052	Work zones: G21, G22.
Page 1053	Tool radius compensation: G40, G41, G42.
Page 1054	Zero offsets.
Page 1055	Millimeters/inches G71, G70.
Page 1056	Scaling factor: G72.
Page 1057	Home search: G74.
Page 1058	Probing: G75.
Page 1059	Axis coupling (slaving): G77, G78.
Page 1060	Absolute/incremental: G90, G91.
Page 1061	Coordinate preset and Polar origin: G92, G93.
Page 1062	Feedrate programming: G94, G95.
Page 1063	Programming of auxiliary functions F, S, T and D.
Page 1064	Programming of auxiliary (miscellaneous) M functions.

Syntax help: CNC tables

Page 1090	Tool offset table.
Page 1091	Tool table.
Page 1092	Tool magazine table.
Page 1093	Auxiliary (miscellaneous) M function table.
Page 1094	Zero offset table.
Page 1095	Leadscrew error compensation tables.
Page 1096	Cross compensation table.
Page 1097	Machine parameter tables.
Page 1098	User parameter tables.
Page 1099	Passwords table.



CNC 8055
CNC 8055i

.T- MODEL
(SOFT V16.1X)

Syntax help: High level language

Page 1100	ERROR and MSG instructions.
Page 1101	GOTO and RPT instructions.
Page 1102	OPEN and WRITE instructions.
Page 1103	SUB and RET instructions.
Page 1104	CALL, PCALL, MCALL, MDOFF and PROBE instructions.
Page 1105	DSBLK, ESBLK, DSTOP, ESTOP, DFHOLD and EFHOLD instructions.
Page 1106	IF instruction.
Page 1107	Assignment blocks.
Page 1108	Mathematical expressions.
Page 1109	PAGE instruction.
Page 1110	ODW instruction.
Page 1111	DW instruction.
Page 1112	IB instruction.
Page 1113	SK instruction.
Page 1114	WKEY and SYSTEM instructions.
Page 1115	KEYSRC instruction.
Page 1116	WBUF instruction.
Page 1117	SYMBOL instruction.

Syntax help: Canned cycles

Page 1076	Pattern repeat cycle canned cycle: G66..
Page 1078	X axis roughing canned cycle: G68.
Page 1079	Z axis roughing canned cycle: G69.
Page 1080	Turning canned cycle for straight sections: G81.
Page 1081	Facing canned cycle for straight sections: G82.
Page 1082	Drilling canned cycle: G83.
Page 1083	Turning canned cycle for curved sections: G84.
Page 1084	Facing canned cycle for curved sections: G85.
Page 1085	Longitudinal threading canned cycle: G86.
Page 1086	Face threading canned cycle: G87.
Page 1087	X axis grooving canned cycle: G88.
Page 1088	Z axis grooving canned cycle: G89.
Page 1089	Tool geometry page.



APPENDIX

Programming assistance screens of the system



**CNC 8055
CNC 8055i**

·T· MODEL
(SOFT V16.1X)

E.

APPENDIX

Programming assistance screens of the system



CNC 8055
CNC 8055i

.T- MODEL
(SOFT V16.1X)

MAINTENANCE

Cleaning

The accumulated dirt inside the unit may act as a screen preventing the proper dissipation of the heat generated by the internal circuitry which could result in a harmful overheating of the CNC and, consequently, possible malfunctions.

On the other hand, accumulated dirt can sometimes act as an electrical conductor and shortcircuit the internal circuitry, especially under high humidity conditions.

To clean the operator panel and the monitor, a smooth cloth should be used which has been dipped into de-ionized water and /or non abrasive dish-washer soap (liquid, never powder) or 75° alcohol.

Do not use highly compressed air to clean the unit because it could generate electrostatic discharges.

The plastics used on the front panel are resistant to :

- Grease and mineral oils.
- Bases and bleach.
- Dissolved detergents.
- Alcohol.



Fagor Automation shall not be held responsible for any material or physical damage derived from the violation of these basic safety requirements.

To check the fuses, first unplug the unit from mains. If the CNC does not turn on when flipping the power switch, check that the fuses are the right ones and they are in good condition.

Avoid solvents. The action of solvents such as chlorine hydrocarbons, benzole, esters and ether may damage the plastics used to make the front panel of the unit.

Do not open this unit. Only personnel authorized by Fagor Automation may open this unit.

Do not handle the connectors with the unit connected to mains. Before manipulating the connectors (inputs/outputs, feedback, etc.) make sure that the unit is not connected to AC power.



APPENDIX
Maintenance

FAGOR 

**CNC 8055
CNC 8055i**

·T· MODEL
(SOFT V16.1X)

F.

APPENDIX



CNC 8055
CNC 8055i

.T- MODEL
(SOFT V16.1X)



CNC 8055
CNC 8055i

·T· MODEL
(SOFT V16.1X)



CNC 8055
CNC 8055i

.T- MODEL
(SOFT V16.1X)