

CNC 8055 / CNC 8055i



**FAGOR** 

REF. 0901

.TC· OPTION  
(SOFT: V16.1X)

## OPERATION MANUAL (.TC· OPTION)

.TC· option  
(Soft: V16.1x)

Ref. 0901



All rights reserved. No part of this documentation may be transmitted, transcribed, stored in a backup device or translated into another language without Fagor Automation's consent.

The information described in this manual may be changed due to technical modifications. Fagor Automation reserves the right to make any changes to the contents of this manual without prior notice.

The trade marks belong to their respective owners.

The content of this manual and its validity for the product described here has been verified. Even so, involuntary errors are possible, thus no absolute match is guaranteed. Anyway, the contents of the manual is periodically checked making and including the necessary corrections in a future edition.

The examples described in this manual are for learning purposes. Before using them in industrial applications, they must be properly adapted making sure that the safety regulations are fully met.

---



# INDEX

About the product.....	I
Declaration of conformity.....	III
Version history (T).....	V
Safety conditions.....	IX
Warranty terms.....	XIII
Material returning terms.....	XV
Additional remarks.....	XVII
Fagor documentation.....	XIX

## CHAPTER 1

### GENERAL CONCEPTS

1.1 Keyboard.....	1
1.2 General concepts.....	3
1.2.1 P999997 text program management.....	6
1.3 Power-up.....	7
1.4 Working in T mode with the TC keyboard.....	8
1.5 Video off.....	8
1.6 Managing the CYCLE START key.....	8

## CHAPTER 2

### OPERATING IN JOG MODE

2.1 Introduction.....	10
2.1.1 Standard screen of the TC mode.....	10
2.1.2 Description of the special screen of the TC mode.....	12
2.1.3 Selecting a program for simulation or execution.....	14
2.2 Axis control.....	15
2.2.1 Work units.....	15
2.2.2 Coordinate preset.....	15
2.2.3 Managing the axis feedrate (F).....	15
2.3 Home search.....	16
2.4 Zero offset table.....	17
2.5 Jog movement.....	19
2.5.1 Moving an axis to a particular position (coordinate).....	19
2.5.2 Incremental movement.....	19
2.5.3 Continuous movement.....	20
2.5.4 Path-jog.....	22
2.5.5 Movement with an electronic handwheel.....	24
2.5.6 Feed handwheel.....	25
2.5.7 Path-handwheel.....	26
2.6 Tool control.....	27
2.6.1 Tool change.....	28
2.6.2 Variable tool change point.....	29
2.7 Tool calibration.....	31
2.7.1 Define the tool in the tool table (level 1).....	32
2.7.2 Manual tool calibration with/without a probe (level 1).....	35
2.7.3 Tool calibration with a probe (level 2).....	37
2.7.4 Probe calibration (level 3).....	40
2.8 Live tool.....	41
2.9 Spindle control.....	43
2.9.1 Spindle in rpm.....	44
2.9.2 Spindle in constant surface speed mode.....	46
2.9.3 Spindle orientation.....	48
2.10 Controlling the external devices.....	50
2.11 ISO management.....	51



CNC 8055  
CNC 8055i

.TC- OPTION  
(SOFT: V16.1x)

**CHAPTER 3**

**WORKING WITH OPERATIONS OR CYCLES**

3.1	Operation editing mode .....	55
3.1.1	Definition of spindle conditions .....	56
3.1.2	Definition of machining conditions .....	57
3.1.3	Cycle level .....	59
3.2	Simulating and executing the operation .....	60
3.2.1	Background cycle editing.....	61
3.3	Positioning cycle.....	62
3.3.1	Definition of data.....	63
3.4	Turning cycle .....	64
3.4.1	Data definition (levels 1 and 2) .....	67
3.4.2	Data definition (levels 3, 4 and 5) .....	69
3.4.3	Basic operation (levels 1 and 2) .....	71
3.5	Facing cycle .....	73
3.5.1	Data definition (levels 1 and 2) .....	76
3.5.2	Data definition (levels 3, 4 and 5) .....	77
3.5.3	Basic operation (levels 1 and 2) .....	79
3.6	Taper turning cycle.....	81
3.6.1	Definition of data.....	82
3.6.2	Basic operation .....	85
3.7	Rounding cycle.....	87
3.7.1	Definition of geometry.....	88
3.7.2	Basic operation .....	91
3.8	Threading cycle .....	93
3.8.1	Definition of geometry.....	96
3.8.2	Standard threads .....	100
3.8.3	Basic operation. Longitudinal threadcutting.....	107
3.8.4	Basic operation. Taper thread .....	108
3.8.5	Basic operation. Face tapping .....	109
3.8.6	Basic operation. Thread repair .....	110
3.9	Grooving cycle.....	111
3.9.1	Calibration of the grooving tool .....	113
3.9.2	Definition of geometry.....	114
3.9.3	Basic operation. Slot milling .....	117
3.9.4	Basic operation. Cut-off .....	119
3.10	Drilling and tapping cycles.....	120
3.10.1	Geometry definition .....	122
3.10.2	Drilling cycle. Basic operation.....	124
3.10.3	Tapping cycle. Basic operation.....	125
3.10.4	Multiple drilling cycle. Basic operation.....	126
3.10.5	Multiple threading cycle. Basic operation .....	127
3.10.6	Multiple slot milling cycle. Basic operation .....	128
3.11	Profiling cycle .....	129
3.11.1	Level 1. Profile definition .....	130
3.11.2	Levels 2, 3 and 4. Profile definition.....	132
3.11.3	Level 2. Optimizing the machining of a profile.....	134
3.11.4	Definition of geometry levels 1 and 2. ZX profile .....	135
3.11.5	Definition of geometry at levels 3 and 4. XC, ZC profiles .....	138
3.11.6	Basic operation at levels 1 and 2. ZX profile .....	139
3.11.7	Basic operation at levels 3 and 4. XC, ZC profiles .....	140
3.11.8	Example. Level 1 .....	141
3.11.9	Examples. Level 2 .....	142

**CHAPTER 4**

**Y AXIS**

4.1	Profiling cycles with Y axis .....	153
4.2	Graphics: XY and ZY plane selection.....	153
4.3	Tool calibration .....	154

**CHAPTER 5**

**OPERATING IN ISO MODE**

5.1	Editing blocks in ISO mode .....	158
5.2	Programming assistance .....	159
5.2.1	Zero offsets and presets.....	159
5.2.2	Work zones.....	159
5.2.3	Place labels and repetitions from label to label .....	159
5.2.4	Mirror image .....	160
5.2.5	Scaling factor.....	160



**CNC 8055**  
**CNC 8055i**

-TC- OPTION  
(SOFT: V16.1X)

**CHAPTER 6**

**SAVING PROGRAMS**

6.1	List of saved programs .....	162
6.2	See the contents of a program .....	163
6.2.1	Seeing one of the operations in detail .....	163
6.3	Edit a new part-program .....	164
6.4	Saving an ISO block or a cycle.....	165
6.5	Delete a new part program .....	166
6.6	Copying a part-program into another one.....	167
6.7	Modify a part-program .....	168
6.7.1	Delete an operation .....	168
6.7.2	Add or insert a new operation .....	168
6.7.3	Move an operation to another position .....	169
6.7.4	Modify an existing operation .....	170
6.8	Managing programs using the explorer .....	171

**CHAPTER 7**

**EXECUTION AND SIMULATION**

7.1	Simulating or executing an operation or cycle .....	174
7.2	Simulating or executing a part-program .....	175
7.2.1	Simulating or executing a portion of a part-program.....	175
7.3	Simulating or executing an operation that has been saved.....	176
7.4	Execution mode.....	177
7.4.1	Tool inspection.....	178
7.5	Graphic representation .....	180



**CNC 8055  
CNC 8055i**

.TC- OPTION  
(SOFT: V16.1X)





# ABOUT THE PRODUCT

## Basic characteristics of the different models.

	8055i/ A 8055 /A	8055i Plus 8055 Plus
Built-in	8055i/ A	8055i Plus
Enclosure	8055 /A	8055 Plus
USB	8055i/ A	8055i Plus
Block processing time without CPU turbo	9 ms	3 ms
* Block processing time with CPU turbo	----	1.5 ms
RAM memory	256 Kb expandable to 1Mb	1 Mb
Software for 7 axes	----	Option
Digitizing	Option	Standard
Tracing	----	Option
TCP transformation	----	Option
C axis (Lathe)	----	Option
Y axis (Lathe)	----	Option
1M RAM - 2M Flash	Option	----

\* Models 8055i /A and 8055i Plus do not have CPU turbo.

## Hardware options of the 8055i CNC.

	Analog	Digital
Hard disk / compact flash	Option	Option
Ethernet	Option	Option
1M RAM - 2M Flash	Option	Option
RS-232 serial line	Standard	Standard
16 digital inputs and 8 outputs (I1 to I16 and O1 to O8)	Standard	Standard
Another 40 digital inputs and 24 outputs (I65 to I104 and O33 to O56)	Option	Option
Probe inputs	Standard	Standard
Spindle (feedback input and analog output)	Standard	Standard
Electronic handwheels	Standard	Standard
4 axes (feedback and analog voltage)	Option	Option
Remote CAN modules, for digital I/O expansion (RIO).	Option	Option
Sercos servo drive system for Fagor servo drive connection.	---	Option
CAN servo drive system for Fagor servo drive connection.	---	Option



Before start-up, verify that the machine that integrates this CNC meets the 89/392/CEE Directive.

**FAGOR**

CNC 8055  
CNC 8055i

**Software options of the 8055 and 8055i CNCs.**

	Model						
	GP	M	MC	MCO	T	TC	TCO
Number of axes with standard software	4	4	4	4	2	2	2
Number of axes with optional software	7	7	7	7	4 or 7	4 or 7	4 or 7
Electronic threading	-----	Stand	Stand	Stand	Stand	Stand	Stand
Tool magazine management:	-----	Stand	Stand	Stand	Stand	Stand	Stand
Machining canned cycles	-----	Stand	Stand	-----	Stand	Stand	-----
Multiple machining	-----	Stand	Stand	-----	-----	-----	-----
Solid graphics	-----	Stand	Stand	Stand	Stand	Stand	Stand
Rigid tapping	-----	Stand	Stand	Stand	Stand	Stand	Stand
Tool live monitoring	-----	Opt	Opt	Opt	Opt	Opt	Opt
Probing canned cycles	-----	Opt	Opt	Opt	Opt	Opt	Opt
DNC	Stand	Stand	Stand	Stand	Stand	Stand	Stand
COCOM version	Opt	Opt	Opt	Opt	Opt	Opt	Opt
Profile editor	Stand	Stand	Stand	Stand	Stand	Stand	Stand
Tool radius compensation	Stand	Stand	Stand	Stand	Stand	Stand	Stand
Tangential control	Opt	Opt	Opt	Opt	Opt	Opt	Opt
Retracing	-----	Opt	Opt	Opt	Opt	Opt	Opt
Setup assistance	Stand	Stand	Stand	Stand	Stand	Stand	Stand
Irregular pockets with islands	-----	Stand	Stand	Stand	-----	-----	-----
Digitizing	-----	Opt	Opt	Opt	-----	-----	-----
Tracing	-----	Opt	Opt	Opt	-----	-----	-----
TCP transformation	-----	Opt	Opt	Opt	-----	-----	-----
C axis (on Lathe)	-----	-----	-----	-----	Opt	Opt	Opt
Y axis (on Lathe)	-----	-----	-----	-----	Opt	Opt	Opt
Telediagnosis	Opt	Opt	Opt	Opt	Opt	Opt	Opt

About the product



CNC 8055  
CNC 8055i

# DECLARATION OF CONFORMITY

## The manufacturer:

Fagor Automation S. Coop.

Barrio de San Andrés 19, C.P. 20500, Mondragón -Guipúzcoa- (SPAIN).

## We declare:

We declare under our exclusive responsibility the conformity of the product:

### **Numerical Control Fagor 8055 and 8055i**

Referred to by this declaration with following directives:

#### **Safety regulations.**

EN 60204-1 Machine safety. Electrical equipment of the machines.

#### **Regulation on electromagnetic compatibility.**

EN 61000-6-4 Generic regulation on emissions in industrial environments.

EN 55011 Radiated. Class A, Group 1.

(\*) EN 55011 Conducted. Class A, Group 1.

(\*) EN 61000-3-2 Current harmonics.

(\*) EN 61000-3-3 Flickers and Voltage fluctuations.

EN 61000-6-2 Generic regulation on immunity in industrial environments.

EN 61000-4-2 Electrostatic discharges.

EN 61000-4-3 Radiofrequency radiated electromagnetic fields.

EN 61000-4-4 Bursts and fast transients.

(\*) EN 61000-4-5 High Voltage conducted pulses (Surges).

EN 61000-4-6 Conducted disturbance induced by radio frequency fields.

EN 61000-4-8 Magnetic fields to Mains frequency.

EN 61000-4-11 Voltage fluctuations and Outages.

ENV 50204 Fields generated by digital radio-telephones.

(\*) Only for the 8055 model

As instructed by the European Community Directives: 73/23/CEE modified by 93/68/EEC on Low Voltage and 89/336/CEE modified by 92/31/EEC and 93/68/EEC on Electromagnetic Compatibility and their updates.

In Mondragón, June 15th 2005.

Fagor Automation S. Coop. Ltda.  
Director Gerente

Fdo.: Julen Busturia

**FAGOR** 

**CNC 8055  
CNC 8055i**



# VERSION HISTORY (T)

(lathe model)

Here is a list of the features added in each software version and the manuals that describe them.

---

## Software V04.0x

December 1999

ISO management, also like MDI.
Coolant icon in all cycles.
Background editing.
Key codes for user cycles.

---

## Software V06.1x

April 2001

DIPLCOF parameter is taken into account.
Repositioning may be aborted.
Avoid undesired executions.
Icon for spindle turning direction.
"S2" representation with second spindle.
Finishing stocks in X-Z.
Cycle level indicating tab.
Threading cycle home angle.
P999997 text program management.

---

## Software V06.2x

December 2001

If Feed-hold active, the feedrate changes color.
--

---

## Software V08.0x

December 2002

Restore the last F, S and Smax values on power-up.
Possibility of hiding unused operations or cycles.
It shows warning messages on a green stripe.
Improvements for executing a part-program.
Threading cycle. It is possible to define the type of standardized thread (except face threading). It is possible to repeat the last pass. New level. Threads with different entries.
Turning cycle. It is now possible to define the finishing stock in X and Z. New level to define the type of corner.
Facing cycle. It is now possible to define the finishing stock in X and Z. New level to define the type of corner.
Taper turning cycle. New level to define the Z distance and the taper angle.



CNC 8055  
CNC 8055i

Grooving cycle. New level. Cut-off.
Profiling cycle. Finishing tool for the XC and ZC cycles. The tool does not withdraw to the safety distance in each roughing pass. Finishing stocks in the XC and ZC cycles. The XC and ZC cycles assume the first point of the profile as the starting point.
Limitations to tool calibration when there is a program in execution or in tool inspection mode.

**Software V08.1x****July 2003**

Threading cycle. Thread exit through the last point.
--

**Software V10.0x****February 2004**

Accessing cycles and programs from the auxiliary screen.
ISO programming assistance.
Zero offset table management.
After an execution or simulation error, it indicates the erroneous cycle.
In execution or simulation, it indicates the cycle number.
The CNC highlights the axis being moved in jog or with handwheels.
Copying a profile.
Select a program by indicating its number.
Point-to-point profiling cycle. When defining the points of the profile, when leaving a data blank, the cycle assumes that it is the repetition of the previous one. It is possible to define the incremental points or coordinates.
Cut-off cycle. The cycle lets define the chamfer angle. The cycle lets work in RPM or CSS mode. The cycle offers the possibility to use coolant only up to the intermediate diameter.
Drilling cycle. The cycle lets define the distance for the tool to withdraw after each drilling peck.
Manual tool calibration using a probe.
Tool calibration with a probe.
Probe calibration.

**Software V10.1x****December 2004**

Being the X-C plane active, the CNC displays transformed coordinates.
---



CNC 8055  
CNC 8055i

**Software V12.01****August 2005**

Y axis as software option.
New icons have in the roughing parameters of the grooving cycles.
Generating an ISO-coded program.

---

**Software V12.11****February 2006**

Displaying the active PLC messages.
Icon for coolant ON/OFF in positioning cycles 1 and 2.

---

**Software V14.01****December 2006**

Improved oscilloscope.
It is possible to select only the roughing or the finishing.
Spindle override change while threading.
Jogging in G95.
Possibility of programming certain M functions in TC.
Profiling cycle 1 and 2 with 45-degree withdrawal.
Approach distance "C" in the drilling cycle.
Customizing the TC for vertical lathes.

---

**Software V16.01****May 2007**

Possibility to delete all the points of a profile.
There are now more zero offsets.
Displaying the S decimals.
Possibility of defining the thread pitch as number of threads per inch.
Tool wear measurement.

---

**Software V16.11****March 2008**

Managing programs from the explorer.
Saving the last 10 MDI instructions..
Icon for gear change when the live tool is the second spindle.
Improvements to the C axis and Y axis. 2D profile pockets.
Threading cycle with variable pitch.

Version history (T)

**FAGOR** **CNC 8055  
CNC 8055i**



Version history (T)



CNC 8055  
CNC 8055i



# SAFETY CONDITIONS

Read the following safety measures in order to prevent harming people or damage to this product and those products connected to it.

This unit may only be repaired by authorized personnel at Fagor Automation.

Fagor Automation shall not be held responsible of any physical damage or defective unit resulting from not complying with these basic safety regulations.

## Precautions against personal damage

---

- ❑ Interconnection of modules  
Use the connection cables provided with the unit.
- ❑ Use proper Mains AC power cables  
To avoid risks, use only the Mains AC cables recommended for this unit.
- ❑ Avoid electrical overloads  
In order to avoid electrical discharges and fire hazards, do not apply electrical voltage outside the range selected on the rear panel of the central unit.
- ❑ Ground connection  
In order to avoid electrical discharges, connect the ground terminals of all the modules to the main ground terminal. Before connecting the inputs and outputs of this unit, make sure that all the grounding connections are properly made.
- ❑ Before powering the unit up, make sure that it is connected to ground  
In order to avoid electrical discharges, make sure that all the grounding connections are properly made.
- ❑ Do not work in humid environments  
In order to avoid electrical discharges, always work under 90% of relative humidity (non-condensing) and 45 °C (113° F).
- ❑ Do not work in explosive environments  
In order to avoid risks or damages, do no work in explosive environments.

## Precautions against product damage

---

- ❑ Working environment  
This unit is ready to be used in industrial environments complying with the directives and regulations effective in the European Community.  
Fagor Automation shall not be held responsible for any damage suffered or caused when installed in other environments (residential or homes).



CNC 8055  
CNC 8055i

**❑ Install this unit in the proper place**

It is recommended, whenever possible, to install the CNC away from coolants, chemical product, blows, etc. that could damage it.

This unit complies with the European directives on electromagnetic compatibility. Nevertheless, it is recommended to keep it away from sources of electromagnetic disturbance such as:

- Powerful loads connected to the same AC power line as this equipment.
- Nearby portable transmitters (Radio-telephones, Ham radio transmitters).
- Nearby radio/TV transmitters.
- Nearby arc welding machines.
- Nearby High Voltage power lines.
- Etc.

**❑ Enclosures**

The manufacturer is responsible of assuring that the enclosure involving the equipment meets all the currently effective directives of the European Community.

**❑ Avoid disturbances coming from the machine tool**

The machine-tool must have all the interference generating elements (relay coils, contactors, motors, etc.) uncoupled.

- DC relay coils. Diode type 1N4000.
- AC relay coils. RC connected as close to the coils as possible with approximate values of  $R=220\ \Omega$  / 1 W and  $C=0,2\ \mu\text{F}$  / 600 V.
- AC motors. RC connected between phases, with values of  $R=300\ \Omega$  / 6 W and  $C=0,47\ \mu\text{F}$  / 600 V.

**❑ Use the proper power supply**

Use an external regulated 24 Vdc power supply for the inputs and outputs.

**❑ Grounding of the power supply**

The zero volt point of the external power supply must be connected to the main ground point of the machine.

**❑ Analog inputs and outputs connection**

It is recommended to connect them using shielded cables and connecting their shields (mesh) to the corresponding pin.

**❑ Ambient conditions**

The working temperature must be between +5 °C and +40 °C (41°F and 104° F)

The storage temperature must be between -25 °C and +70 °C. (-13 °F and 158 °F)

**❑ Monitor enclosure (8055) or central unit (8055i)**

Guarantee the required gaps between the monitor or the central unit and each wall of the enclosure. Use a DC fan to improve enclosure ventilation.

**❑ Power switch**

This power switch must be mounted in such a way that it is easily accessed and at a distance between 0.7 meters (27.5 inches) and 1.7 meters (5.5ft) off the floor.



CNC 8055  
CNC 8055i

## Protections of the unit itself (8055)

- ❑ Modules: "Axes", "Inputs/Outputs" and "Inputs/Outputs & Tracing"

All the digital inputs and outputs have galvanic isolation via optocouplers between the CNC circuitry and the outside.

They are protected by an external fast fuse (F) of 3.15 A 250V against overvoltage of the external power supply (over 33 Vdc) and against reverse connection of the power supply.

- ❑ Monitor

The type of protection fuse depends on the type of monitor. See identification label of the unit itself.

## Protections of the unit itself (8055i)

- ❑ Central unit

It has a 4 A 250V external fast fuse (F).

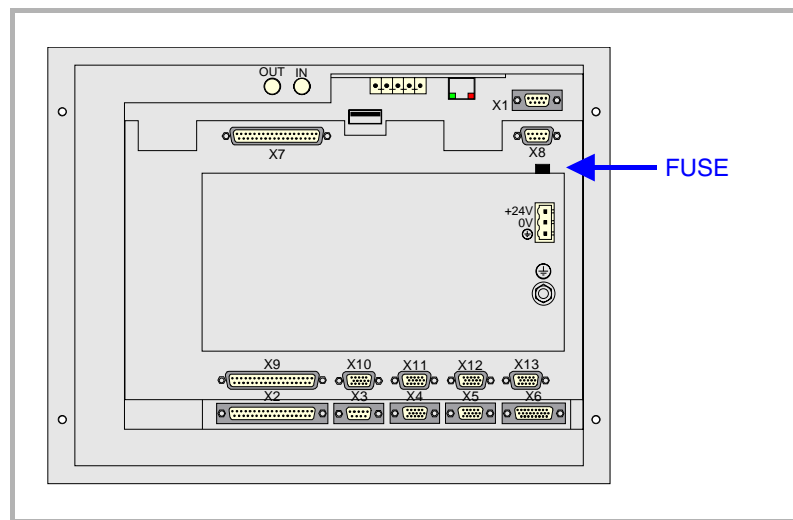

- ❑ Inputs-Outputs

All the digital inputs and outputs have galvanic isolation via optocouplers between the CNC circuitry and the outside.

## Precautions during repair



*Do not open this unit. Only personnel authorized by Fagor Automation may open this unit.*

*Do not handle the connectors with the unit connected to mains. Before manipulating the connectors (inputs/outputs, feedback, etc.) make sure that the unit is not connected to AC power.*

## Safety symbols

---

- Symbols which may appear on the manual.



*Symbol for danger or prohibition.*

*It indicates actions or operations that may cause damage to people or to units.*

---



*Warning symbol.*

*It indicates situations that may be caused by certain operations and the actions to be taken to prevent them.*

---



*Obligation symbol.*

*It indicates actions and operations that must be carried out.*

---



*Information symbol.*

*It indicates notes, warnings and advises.*

---

# WARRANTY TERMS

## **Initial warranty**

---

All products manufactured or marketed by FAGOR carry a 12-month warranty for the end user which could be controlled by the our service network by means of the warranty control system established by FAGOR for this purpose.

In order to prevent the possibility of having the time period from the time a product leaves our warehouse until the end user actually receives it run against this 12-month warranty, FAGOR has set up a warranty control system based on having the manufacturer or agent inform FAGOR of the destination, identification and on-machine installation date, by filling out the document accompanying each FAGOR product in the warranty envelope. This system, besides assuring a full year of warranty to the end user, enables our service network to know about FAGOR equipment coming from other countries into their area of responsibility.

The warranty starting date will be the one appearing as the installation date on the above mentioned document. FAGOR offers the manufacturer or agent 12 months to sell and install the product. This means that the warranty starting date may be up to one year after the product has left our warehouse so long as the warranty control sheet has been sent back to us. This translates into the extension of warranty period to two years since the product left our warehouse. If this sheet has not been sent to us, the warranty period ends 15 months from when the product left our warehouse.

This warranty covers all costs of material and labour involved in repairs at FAGOR carried out to correct malfunctions in the equipment. FAGOR undertakes to repair or replace their products within the period from the moment manufacture begins until 8 years after the date on which it disappears from the catalogue.

FAGOR has exclusive competence in deciding whether the repair enters within the term defined as the warranty period.

## **Excluding clauses**

---

Repairs will be carried out on our premises. Therefore, all expenses incurred as a result of trips made by technical personnel to carry out equipment repairs, despite these being within the above-mentioned period of warranty, are not covered by the warranty.

Said warranty will be applied whenever the equipment has been installed in accordance with instructions, has not be mistreated, has not been damaged by accident or by negligence and has not been tampered with by personnel not authorised by FAGOR. If, once servicing or repairs have been made, the cause of the malfunction cannot be attributed to said elements, the customer is obliged to cover the expenses incurred, in accordance with the tariffs in force.

Other warranties, implicit or explicit, are not covered and FAGOR AUTOMATION cannot be held responsible for other damages which may occur.



CNC 8055  
CNC 8055i

## Warranty on repairs

---

In a similar way to the initial warranty, FAGOR offers a warranty on standard repairs according to the following conditions:

<b>PERIOD</b>	12 months.
<b>CONCEPT</b>	Covers parts and labor for repairs (or replacements) at the network's own facilities.
<b>EXCLUDING CLAUSES</b>	The same as those applied regarding the chapter on initial warranty. If the repair is carried out within the warranty period, the warranty extension has no effect.

When the customer does not choose the standard repair and just the faulty material has been replaced, the warranty will cover just the replaced parts or components within 12 months.

For sold parts the warranty is 12 months length.

## Maintenance contracts

---

The SERVICE CONTRACT is available for the distributor or manufacturer who buys and installs our CNC systems.



CNC 8055  
CNC 8055i

# MATERIAL RETURNING TERMS

When sending the central nit or the remote modules, pack them in its original package and packaging material. If the original packaging material is not available, pack it as follows:

1. Get a cardboard box whose three inside dimensions are at least 15 cm (6 inches) larger than those of the unit. The cardboard being used to make the box must have a resistance of 170 kg. (375 pounds).
2. Attach a label indicating the owner of the unit, person to contact, type of unit and serial number.
3. In case of failure, also indicate the symptom and a short description.
4. Wrap the unit in a polyethylene roll or similar material to protect it.
5. When sending the central unit, protect especially the screen.
6. Pad the unit inside the cardboard box with polyurethane foam on all sides.
7. Seal the cardboard box with packing tape or industrial staples.



CNC 8055  
CNC 8055i



Material returning terms



CNC 8055  
CNC 8055i



## ADDITIONAL REMARKS

Mount the CNC away from coolants, chemical products, blows, etc. which could damage it. Before turning the unit on, verify that the ground connections have been properly made.

To prevent electrical shock at the central unit of the 8055 CNC, use the proper mains AC connector at the power supply module. Use 3-wire power cables (one for ground connection).

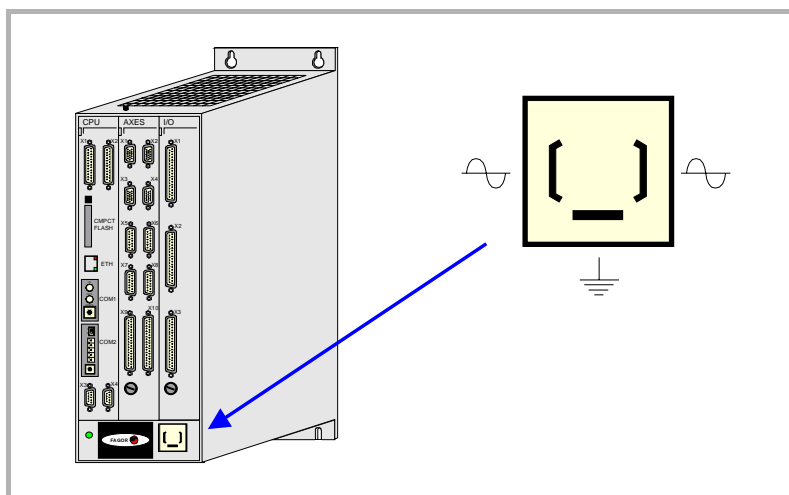

To prevent electrical shock at the monitor of the 8055 CNC, use the proper mains AC connector (A) with 3-wire power cables (one of them for ground connection).

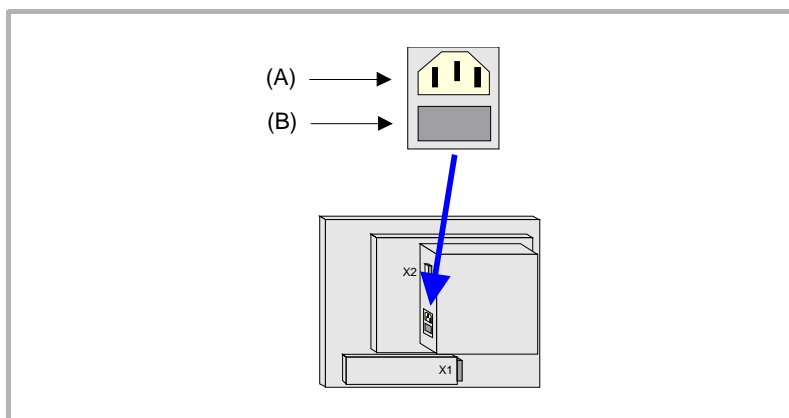

Before turning on the monitor of the 8055 CNC and verifying that the external AC line (B) fuse of each unit is the right one. See identification label of the unit itself.

In case of a malfunction or failure, disconnect it and call the technical service. Do not get into the inside of the unit.

**FAGOR** 

CNC 8055  
CNC 8055i



Additional remarks



CNC 8055  
CNC 8055i

# FAGOR DOCUMENTATION

## **OEM manual**

It is directed to the machine builder or person in charge of installing and starting-up the CNC.

## **USER-M manual**

Directed to the end user.

It describes how to operate and program in M mode.

## **USER-T manual**

Directed to the end user.

It describes how to operate and program in T mode.

## **MC Manual**

Directed to the end user.

It describes how to operate and program in MC mode.

It contains a self-teaching manual.

## **TC Manual**

Directed to the end user.

It describes how to operate and program in TC mode.

It contains a self-teaching manual.

## **MCO/TCO model**

Directed to the end user.

It describes how to operate and program in MCO and TCO mode.

## **Examples-M manual**

Directed to the end user.

It contains programming examples for the M mode.

## **Examples-T manual**

Directed to the end user.

It contains programming examples for the T mode.

## **WINDNC Manual**

It is directed to people using the optional DNC communications software.

It is supplied in a floppy disk with the application.

## **WINDRAW55 manual**

Directed to people who use the WINDRAW55 to create screens.

It is supplied in a floppy disk with the application.



CNC 8055  
CNC 8055i



Fagor documentation



CNC 8055  
CNC 8055i

# GENERAL CONCEPTS

# 1

## 1.1 Keyboard

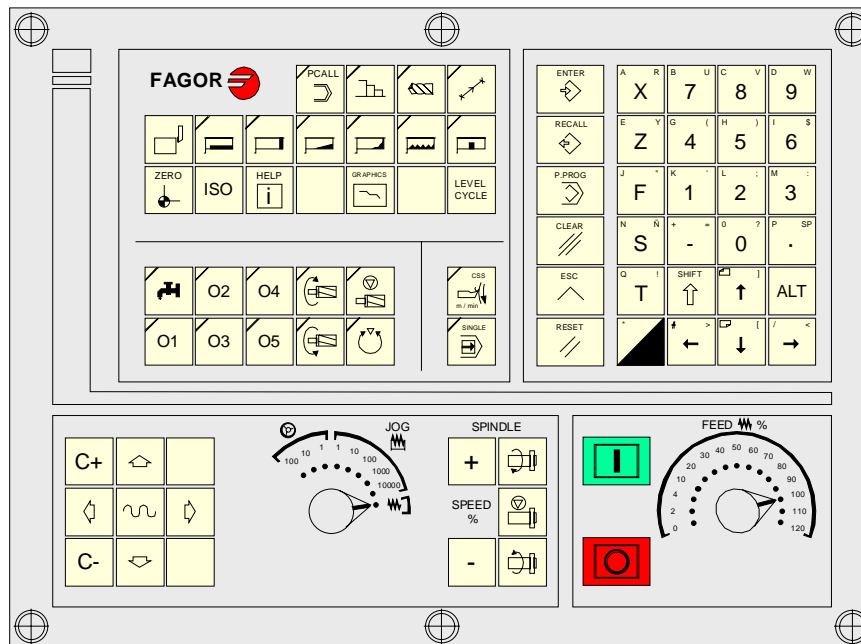

### Alphanumeric keyboard and command keys

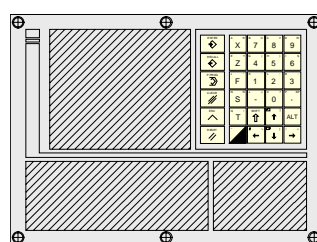

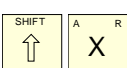
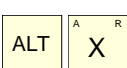
-  Select the X character.
-  Select the A character.
-  Select the R character.

### Specific keys of the TC model

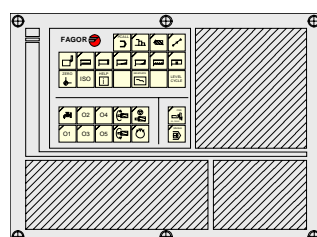

These keys may be used for:

- Selecting and defining the machining operations.
- Govern the external devices.
- Selecting the spindle work mode.
- Selecting the single block or automatic execution Mode.



CNC 8055  
CNC 8055i

-TC- OPTION  
(SOFT: V16.1X)

## JOG keys

---

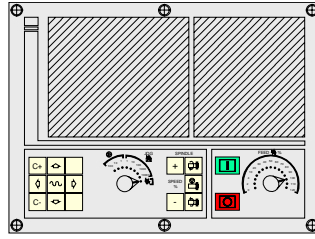

These keys may be used for:

- Moving the axes of the machine.
- Governing the spindle.
- Modifying the feedrate of the axes and the spindle speed.
- Starting and stopping the execution.

1.

**GENERAL CONCEPTS**  
Keyboard



CNC 8055  
CNC 8055i

.TC. OPTION  
(SOFT: V16.1X)

## 1.2 General concepts

It offers all the features of the T model plus those specific of the TC mode. For example, the CNC setup must be done in T mode.

In TC work mode, programs P900000 through P999999 are reserved for the CNC itself; in other words, the user cannot use them as part-programs.

On the other hand, in order to work in TC mode, the CNC must have programs P999997 and P999998 stored in its memory. Both programs are related to the software version and, consequently, are not supplied by Fagor Automation. Whenever the CNC detects a new software version, it updates these programs automatically and, for safety, it makes a copy of the old ones in the KeyCF.

Likewise, subroutines 0000 through 8999 are free to use and subroutines 9000 through 9999 are reserved for the CNC.



*programs P999997 and P999998 are associated with the software version. Fagor Automation shall not be held responsible of the CNC's performance if programs P999997 and P999998 have been deleted from memory or do not match the software version.*

### Subroutines reserved for the CNC

Some of the subroutines reserved for the CNC have the following meaning:

9998 Subroutine that the CNC will execute at the beginning of each part-program.

9999 Subroutine that the CNC will execute at the end of each part-program.

Every time a new part-program is edited, the CNC inserts a call to the relevant subroutine at the beginning and at the end of the program.

Both subroutines must be defined by the machine manufacturer, even when no operation is to be carried out at the beginning and at the end of the part-program. If they are not defined, the CNC will issue an error message when trying to execute a part-program.

Example of how to define subroutine 9998.

```
( SUB 9998 ) ; Definition of subroutine 9998.
. . . ; Program blocks defined by the OEM.
( RET ) ; End of subroutine.
```

### OEM (manufacturer's) parameters

OEM parameters and subroutines with OEM parameters can only be used in OEM programs; those defined with the [O] attribute. Modifying one of these parameters in the tables requires an OEM password.

When using OEM parameters in the configuration programs, this program must have the [O] attribute; otherwise, the CNC will issue an error when editing the user cycles that refer to OEM parameters in write mode.

1.

GENERAL CONCEPTS  
General concepts

FAGOR

CNC 8055  
CNC 8055i

.TC- OPTION  
(SOFT: V16.1X)

## Programs reserved for the CNC

Some of the programs reserved for the CNC have the following meaning:

**P999998** It is a program of subroutines that the CNC uses to interpret the programs edited in TC format and execute them later on.



*This program must not be modified. If this program is modified or deleted, Fagor Automation will not be held responsible of the CNC's performance.*

*If the manufacturer needs to create his own subroutines (for home search, tool change, etc.), as well as subroutines 9998 and 9999, they must be included in another program, for example P899999.*

**P999997** It is a text program that contains:

- The sentences and texts that will be displayed on the various screens of the TC mode.
- The help texts for the icons, in the work cycles, that are shown on the lower left side of the screen.
- The messages (MSG) and errors (ERR) that may come up at the TC model.

All the texts, messages and errors that may be translated into the desired language.



*When modifying program 999997, it is recommended to make a backup copy of it because the CNC replaces that program when selecting another language or updating the software version.*

### Considerations about the texts

The format of a line is as follows:

;Text number - explanatory comment (not displayed) - \$Text to be displayed

All the program lines must begin with the ";" character and the text to be displayed must be preceded by the "\$" symbol. If a line begins with ";;", the CNC assumes that the whole line is a program comment.

Examples:

;44 \$M/MIN	Is message 44 and displays the text "M/MIN"
;;General text	The CNC treats it as a comment
;;44 Feedrate \$M/MIN	The CNC treats it as a comment
;44 Feedrate \$M/MIN	Is message 44 whose hidden explanatory comment is "Feedrate" and displays the text "M/MIN"

### Considerations about the messages

The format must be respected. Only the text after SAVEMSG may be translated:

Example:

Original message:	N9500(MSG"SAVEMSG: TURNING CYCLE")
Translated message:	N9500(MSG"SAVEMSG: ZILINDRAKETA ZIKLOA")

1.

GENERAL CONCEPTS  
General concepts



CNC 8055  
CNC 8055i

-TC- OPTION  
(SOFT: V16.1X)



**Considerations about the errors**

The format must be respected. Only the text between quote marks ("text") may be translated.

Example:

Original text: N9000(ERROR"Cycle without roughing")

Translated text: N9000(ERROR"Arbastatu gabeko zikloa")

**P998000** They are the profiles defined by the user with the profile editor. In the TC mode, the  
 ... user defines them with 3 digits (from 0 to 999) and the CNC saves them internally  
**P998999** as P998xxx.



**GENERAL CONCEPTS**  
 General concepts



**CNC 8055**  
**CNC 8055i**

.TC- OPTION  
 (SOFT: V16.1X)

## 1.2.1 P999997 text program management

1.

**GENERAL CONCEPTS**  
General concepts

On power up, the CNC copies the texts of program P999997 into the system memory.

- It checks if program P999997 is in user memory, if not, it looks in the KeyCF and if it is not there either, it assumes the default ones and copies them into program P999997 of the user memory.
- When selecting mainland Chinese, it ignores program P999997 and it always assumes the default ones.

If when switching from T mode to TC or TCO mode, it cannot find program P999997 because it has been deleted, it is initialized like on power-up.

When modifying the texts of program P999997, turn the CNC off and back on so it assumes the new texts.

The CNC carries out the following operations when changing the language, the software version and when adding TC, TCO conversational modes (new software features):

- It copies, for safety, the texts that were being used into KeyCF as program P999993.
- It deletes the program P999997 that may be in the KeyCF.
- It assumes the new texts that are provided by default and copies them into program P999997 of the user memory.

To change the texts, after modifying program P999997, turn the CNC off and back on so it assumes the new texts.



CNC 8055  
CNC 8055i

-TC- OPTION  
(SOFT: V16.1X)

### 1.3 Power-up

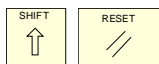

On power-up and after the keystroke sequence [SHIFT] [RESET], the CNC shows "page 0" defined by the manufacturer; if there is no "page 0", it shows the standard screen of the work mode. Press any key to access the work mode.

The standard screen of the TC mode is the following:

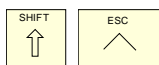
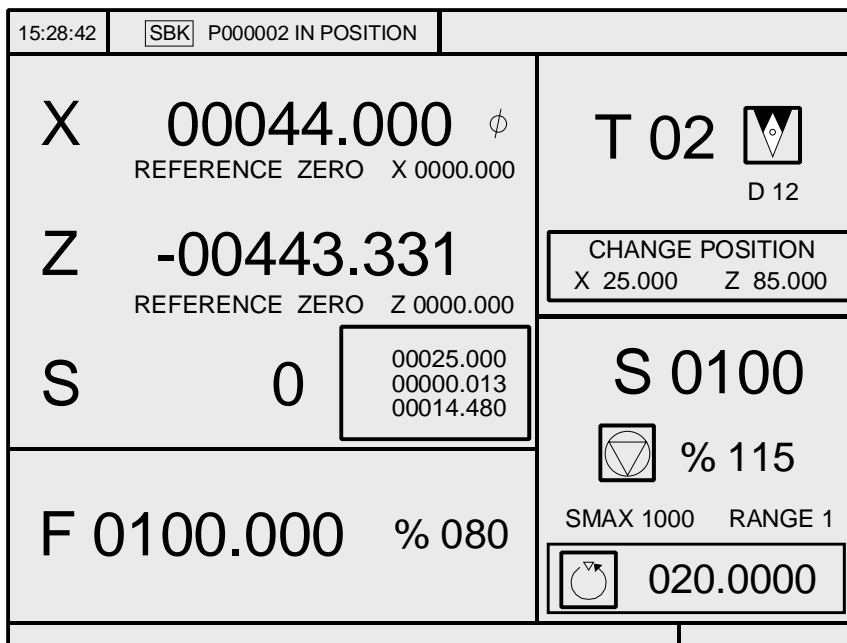

There are two work modes; TC mode and T mode. Press the key sequence [SHIFT] [ESC] to toggle from one mode to the other.



*The CNC setup must be done in T mode.  
Likewise, some errors must be eliminated in T mode.*

# 1.

GENERAL CONCEPTS  
Power-up



CNC 8055  
CNC 8055i

.TC· OPTION  
(SOFT: V16.1X)

## 1.4 Working in T mode with the TC keyboard

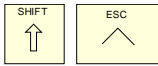

There are two work modes; TC mode and T mode. Press the key sequence [SHIFT] [ESC] to toggle from one mode to the other.

The TC keyboard is designed for also working in T mode. In M mode, use the alphanumeric keyboard and the keys that replace the softkeys F1 through F7.

Alphanumeric keyboard:

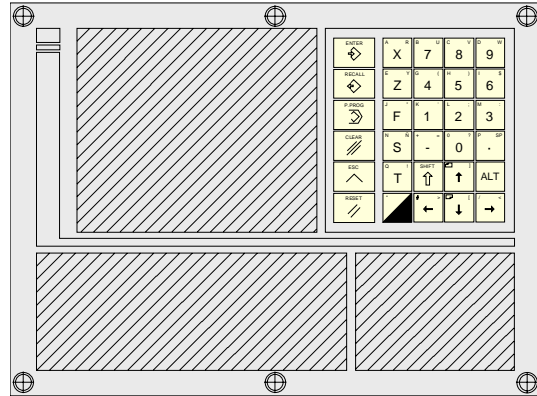

The keys that replace the softkeys F1 through F7 are:

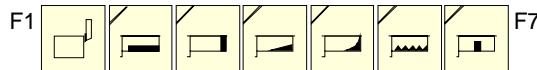

## 1.5 Video off

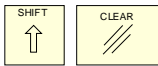

The keystroke sequence [SHIFT] [CLEAR] clears the CRT screen (it goes blank). Press any key to restore the image.

Also, any message (PLC, program, etc.) restores the CNC image.

## 1.6 Managing the CYCLE START key

In order to avoid undesired executions when pressing key sequences that are not supported in TC mode, the CNC changes the "Start" icon at the top of the window from green to gray and shows a message indicating that it is an invalid action.

For example, if "M3 Start" is pressed (sequence not supported in TC mode) while a part-program is selected, the CNC issues a warning and prevents the selected part-program from running when detecting the "Start" key.

**1.**  
**GENERAL CONCEPTS**  
 Working in T mode with the TC keyboard





CNC 8055  
CNC 8055i

.TC- OPTION  
(SoFT: V16.1X)

# OPERATING IN JOG MODE

# 2

The standard screen of the TC mode is the following:

15:28:42		[SBK] P000002 IN POSITION	
X	00044.000 $\phi$	T 02	
	REFERENCE ZERO X 0000.000		D 12
Z	-00443.331	CHANGE POSITION	
	REFERENCE ZERO Z 0000.000	X 25.000 Z 85.000	
S	0	S 0100	
	00025.000 00000.013 00014.480	 % 115	
F	0100.000 % 080	SMAX 1000 RANGE 1	
		 020.0000	

When pressing the [TWO-COLOR] key, the CNC shows the special screen of the TC mode.

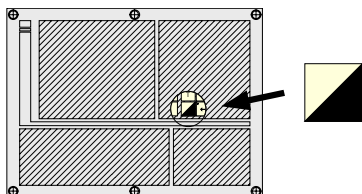

15:28:42		[SBK] P000002 IN POSITION	
M0 (MSG " " ) (IF P102 EQ 1 GOTO N10) (IF P101 EQ 0 RET) M3 (RET) N10 M4 (RET)		G01 G18  M41  PARTC : 000000 CYTIME : 00:00:00:00 TIMER: : 000000:00:00	
COMMAND	ACTUAL	TO GO	FOLLOWING ERROR
X 00020.000	X 00020.000	X 00000.000	X 00000.000
Z 00089.520	Z 00089.520	Z 00000.000	Z 00000.000
C 00014.480	C 00014.480	C 00000.000	C 00000.000
THEORETICAL	RPM	M/MIN	
S 0.0000	S 0.0000	S 0.0000	S 0.0000
U 00025.000	B 00000.013		



CNC 8055  
CNC 8055i

.TC- OPTION  
(SOFT: V16.1x)

## 2.1 Introduction

### 2.1.1 Standard screen of the TC mode

The standard screen of the TC mode offers the following data:

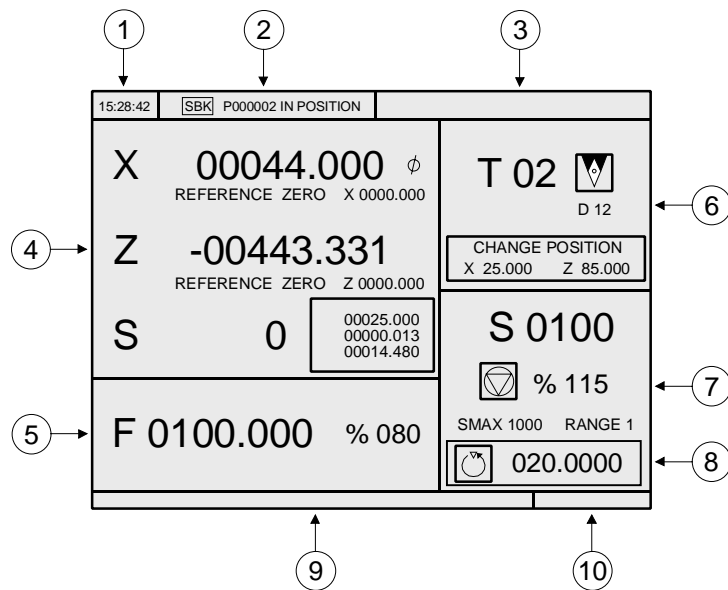

1. Clock.
2. This window may show the following data:
  - SBK when "single block" execution mode is selected.
  - DNC when the DNC mode is active.
  - P.... number of the program currently selected.
  - Message "In position" - "Execution" - "Interrupted" - "RESET".
  - PLC messages.
3. This window shows the CNC messages.
4. This window may show the following data:
  - X, Z coordinates of the axes. The Ø symbol indicates that the axis is working in diameter.
  - In small characters, the axis coordinates referred to machine reference zero. These values are useful when letting the user define a tool change point (see zone 6)
  - The CNC shows this data when text 33 of program 999997 has not been defined.
  - The coordinates of the auxiliary axes that are defined.
  - The "C" axis will only be displayed when it is enabled (G15) and may be governed manually with the jog keys [C+] and [C-]. Being the X-C plane active, the coordinates shown correspond to the transformed coordinates; not to the machine coordinates.
  - The actual spindle rpm (S symbol) or the actual rpm of the second spindle (S2 symbol).
5. The information shown in this window depends on the position of the left switch.
  - In all cases, it shows the axis feedrate "F" currently selected and the % of F being applied.
  - When feed-hold is active, the color of the feedrate value changes.

# 2.

OPERATING IN JOG MODE  
Introduction



CNC 8055  
CNC 8055i

-TC- OPTION  
(SOFT: V16.1X)

Here are all the possible cases.

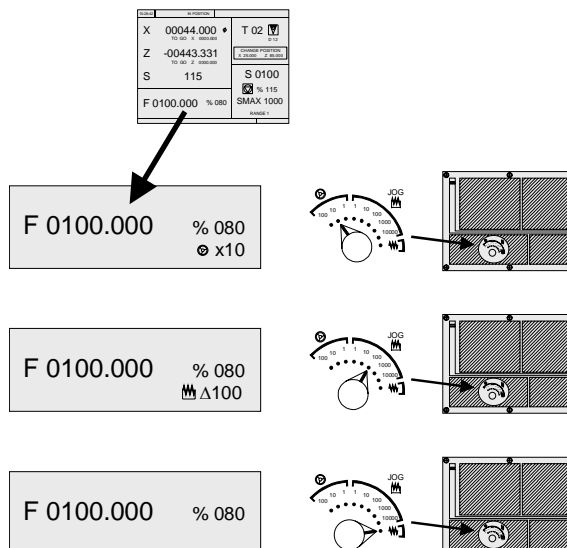

6. This window shows, in large characters, the selected tool number "T" and, in small characters, the "D" offset associated with the tool. If the tool number and the offset number are the same, the CNC will not show the "D" value. The window also shows a drawing of the location code (shape) associated with the tool.

This window also shows the coordinates of the tool change point referred to machine reference zero. The CNC does not show this window when text 47 of program 999997 has not been defined.

7. This window shows everything related to the spindle:

The theoretical turning speed that is selected; "S" value when constant turning speed and "CSS" value when working at constant surface speed.

The spindle status. It is represented with an icon and may be turning clockwise, counterclockwise or stopped.

The % of spindle speed being applied.

The maximum spindle rpm.

The active spindle speed gear (range). The CNC does not show this data when text 28 of program 999997 has not been defined.

8. Spindle angular increment when working in spindle orientation mode.

9. When accessing a work cycle, this window shows the help text associated with the selected icon.

That help text must be defined in program P999997 and edited in the desired language. See chapter "1 General concepts".

10. Reserved.

### Displaying the active PLC messages

At the screen, press [+] of the alphanumeric keyboard, the CNC shows a window with all the active PLC messages. Besides, this window is also displayed whenever there is a program in execution.

The [▲][▼][PAGE UP][PAGE DOWN] keys are used to move around the messages. The [ESC] key is used to close the window.

The window is only displayed when there are more than one active message.

### Direct access to the oscilloscope

The oscilloscope may be accessed from the standard screen by pressing "7" and then "1" as long as no data is being written into any field.

## 2.1.2 Description of the special screen of the TC mode

The special screen of the TC mode offers the following data:

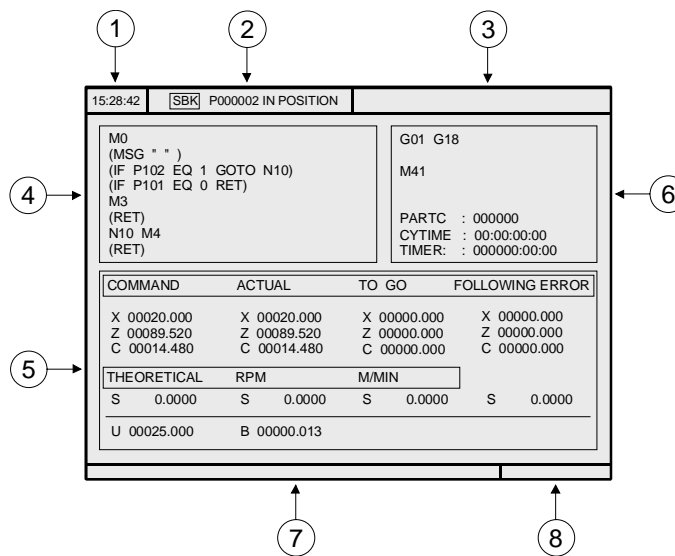

1. Clock.
2. This window may show the following data:
  - SBK when "single block" execution mode is selected.
  - DNC when the DNC mode is active.
  - P.... number of the program currently selected.
  - Message "In position" - "Execution" - "Interrupted" - "RESET".
  - PLC messages.
3. This window shows the CNC messages.
4. This window shows the lines of the program currently selected.
5. The X, Z, C axes have the following fields:

COMANDO	It indicates the programmed coordinate or position that the axis must reach.
ACTUAL	It indicates the actual (current) position of the axis.
REST	It indicates the distance which is left to run to the programmed coordinate.
FOLLOWING ERROR	Difference between the theoretical value and the real value of the position.

The spindle (S) has the following fields:

THEORETICAL	Programmed theoretical S speed.
RPM	Speed in rpm.
M/MIN	Speed in meters per minute.
FOLLOWING ERROR	When working with spindle orientation (M19), it indicates the difference between the theoretical and the real speeds.

The auxiliary axes only show the real current position of the axis.

Being the X-C plane active, the coordinates shown in the "Actual" field correspond to the transformed coordinates; not to the machine coordinates.

# 2.

OPERATING IN JOG MODE  
Introduction



CNC 8055  
CNC 8055i

-TC- OPTION  
(SOFT: V16.1X)



6. This window shows the status of the "G" functions and the auxiliary "M" functions that are active. Likewise, it shows the value of the variables.

PARTC	It indicates the number of consecutive parts executed with the same part-program.  Every time a new program is selected, this variable is reset to "0".
CYTIME	It indicates the time elapsed while executing the part. It is given in "hours : minutes : seconds : hundredths of a second".  Every time a part-program execution starts, even when repetitive, this variable is reset to "0".
TIMER	It indicates the count of the timer enabled by PLC. It is given in "hours : minutes : seconds".

7. Reserved.  
8. Reserved.

### ***Displaying the active PLC messages***

At the screen, press [+] of the alphanumeric keyboard, the CNC shows a window with all the active PLC messages. Besides, this window is also displayed whenever there is a program in execution.

The [↑] [↓] [PAGE UP] [PAGE DOWN] keys are used to move around the messages. The [ESC] key is used to close the window.

The window is only displayed when there are more than one active message.

### ***Direct access to the oscilloscope***

The oscilloscope may be accessed from the auxiliary screen by pressing "7" and then "1" as long as no data is being written into any field.

### 2.1.3 Selecting a program for simulation or execution

When selecting a part-program or operation saved as part of a part-program for simulation or execution, the CNC selects that part-program and shows it highlighted next to the green "start" symbol in the top center window.

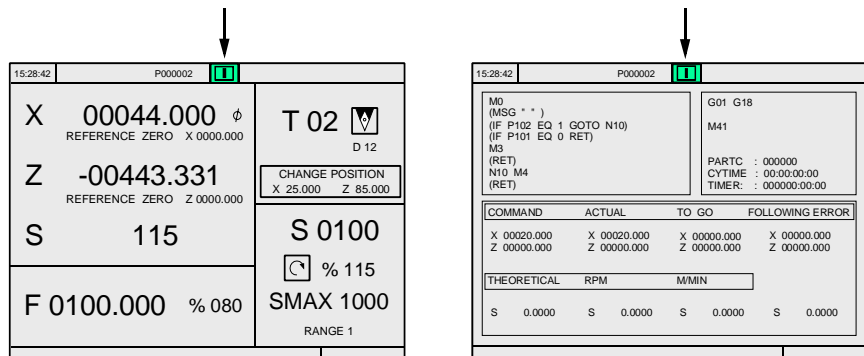

When the top center window shows the part-program selected next to the green "start" symbol, the CNC acts as follows:

- If [START] is pressed, the CNC executes the part-program that is selected.
- If [CLEAR] is pressed, the CNC de-selects the part-program and removes it from the top center window.

# 2.

OPERATING IN JOG MODE  
Introduction



CNC 8055  
CNC 8055i

.TC- OPTION  
(SoFT: V16.1X)

## 2.2 Axis control

### 2.2.1 Work units

When accessing the TC mode, the CNC assumes the work units «mm or inches», «mm/min. or mm/rev», «radius or diameter» etc. selected by machine parameter.

To modify those values, access the T mode and change the corresponding machine parameter.

### 2.2.2 Coordinate preset

The coordinates must be preset on one axis at a time proceeding as follows:

1. Press the key of the desired axis, [X] or [Z].  
The CNC will highlight the coordinate of that axis indicating that it is selected.
2. Key in the value to preset the axis.  
To quit the preset mode, press [ESC].
3. Press [ENTER] for the CNC to assume that value as the new value for the point.  
The CNC requests confirmation of the command. Press the [ENTER] to confirm it or [ESC] to quit the preset mode.

### 2.2.3 Managing the axis feedrate (F)

To set a particular axis feedrate value, proceed as follows:

1. Press the [F] key.  
The CNC will highlight the current value that it is selected.
2. Key in the desired new feedrate value.  
To quit the preset selection mode, press [ESC].
3. Press [START] for the CNC to assume that value as the new value for axis feedrate.

2.

OPERATING IN JOG MODE  
Axis control



CNC 8055  
CNC 8055i

.TC- OPTION  
(SOFT: V16.1X)

## 2.3 Home search

Home search may be done in 2 ways:

- Homing all the axes.
- Homing a single axis.

# 2.

OPERATING IN JOG MODE  
Home search

### Homing all the axes

To home all the axes, press [ZERO].

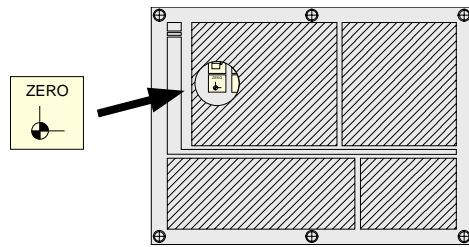

The CNC requests confirmation of the command (text 48 of program 999997). Press [START], the CNC will execute the home search subroutine defined by the OEM in general machine parameters P34 (REFPSUB).



*After searching home this way, the CNC will maintain the part zero or zero offset active at the time.*

*A home search subroutine (general machine parameter P34 other than 0) must be defined when using this method. Otherwise, the CNC will display the corresponding error.*

### Homing a single axis

To home a single axis, press the key of the desired axis and the key for home search.

In either case, the CNC requests confirmation of the command (text 48 of program 999997).

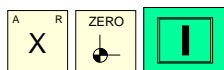

It homes the X axis.

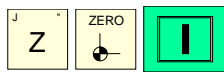

It homes the Z axis.



*After searching home this way, the CNC will not maintain the part zero or zero offset active at the time and assumes the machine reference zero as the new part zero.*



CNC 8055  
CNC 8055i

-TC- OPTION  
(SOFT: V16.1X)

## 2.4 Zero offset table

It is possible to manage the zero offset table (G54 ... G59, G159N7 ... G159N20) from the conversational mode. This table contains the same values as that of the conversational mode.

Press the [ZERO] key to access the zero offset table as well as to get out of it. The zero offset table may be accessed in the following ways.

- From the standard screen, as long as no axis is selected. The CNC will request confirmation of the command.
- From ISO mode, when the "zero offsets and presets" cycle is selected.

The zero offset table looks like this. It shows all the offsets, PLC offset included, and their value in each axis.

	X	Z	V
PLC	0.0000	0.0000	0.0000
G54	0.0000	0.0000	0.0000
G55	0.0000	0.0000	0.0000
G56	0.0000	0.0000	0.0000
G57	0.0000	0.0000	0.0000
ΔG58	0.0000	0.0000	0.0000
ΔG59	0.0000	0.0000	0.0000

When scrolling the focus through the table, the elements appear in different colors as follows.

Color	Meaning
Green background. Text in white.	The real value of the table and the value shown on the screen are the same.
Red background. White text.	The real value of the table and the value shown on the screen are NOT the same. The value on the table has been changed, but it has not been validated. Press [ENTER] to validate the change.
Blue background.	The zero offset is active. There may be two active zero offsets at the same time, one absolute (G54 ... G57, G159N7 ... G159N20) and another one incremental (G58-G59).

### How to edit the table data

The following operations are possible in the zero offset table. Press [ENTER] to validate any changes.

- Editing a zero offset.  
It is edited one axis at a time. Select a data with the focus and edit its value. If the focus is placed on a zero offset (G54 ... G59, G159N7 ... G159N20), the editing begins on the first axis of that zero offset.
- Load the active zero offset into the table.  
Place the focus on the zero offset to be defined (G54 ... G59, G159N7 ... G159N20) and press the [RECALL] key. The active preset is saved in the selected zero offset.  
If instead of placing the focus on a zero offset, it is placed on one of the axes, only that axis will be affected.

2.

OPERATING IN JOG MODE

Zero offset table



CNC 8055  
CNC 8055i

.TC- OPTION  
(SOFT: V16.1X)

## 2.

### OPERATING IN JOG MODE

Zero offset table

- Deleting a zero offset.

Place the focus on the zero offset to be deleted (G54 ... G59, G159N7 ... G159N20) and press the [CLEAR] key. All the axes of that zero offset are reset to zero.

If instead of placing the focus on a zero offset, it is placed on one of the axes, only that axis will be affected.



CNC 8055  
CNC 8055i

.TC. OPTION  
(SOFT: V16.1X)

## 2.5 Jog movement

When making a move in manual, both in jog and with handwheels, the moving axis appears in reverse video.

- With gantry axes, only the master axis is highlighted.
- With a path handwheel, no axis is highlighted; but it is in path-jog.

### 2.5.1 Moving an axis to a particular position (coordinate)

The movements of axes to a particular coordinate are made one at a time as follows

- [X] target coordinate [START]
- [Z] target coordinate [START]

### 2.5.2 Incremental movement

Turn the JOG switch to one of the JOG positions.

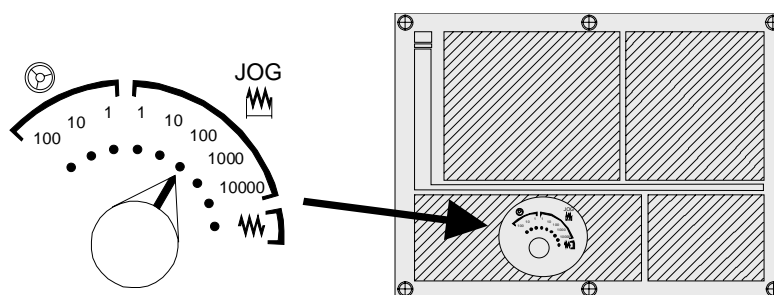

The incremental movement must be made one axis at a time. To do that, press the JOG keys for the direction of the axis to be jogged.

Every time a key is pressed, the corresponding axis moves the amount set by the switch. This movement is made at the selected feedrate (F).

Switch position	Distance
1	0.001 mm or 0.0001 inches
10	0.010 mm or 0.0010 inches
100	0.100 mm or 0.0100 inches
1000	1.000 mm or 0.1000 inches
10000	10.000 mm or 1.0000 inches

2.

OPERATING IN JOG MODE  
Jog movement



CNC 8055  
CNC 8055i

-TC- OPTION  
(SOFT: V16.1X)

## 2.5.3 Continuous movement

Place the movement selector in the continuous-jog position and select at the feedrate override switch (FEED) the percentage (0% to 120%) of the feedrate to be applied.

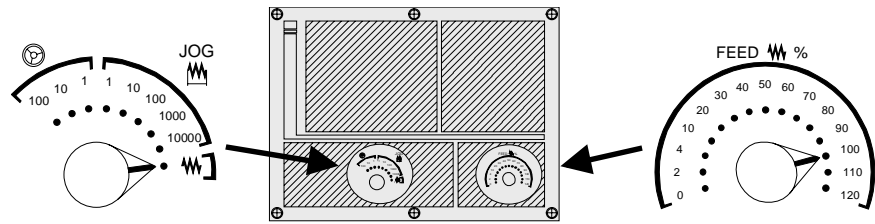

The continuous jog must be made one axis at a time. To do that, press the JOG keys for the direction of the axis to be jogged.

The axis moves at a feedrate equal to the selected percentage (0% to 120%) of feedrate "F".



If while jogging an axis, the rapid key is pressed, the axis will move at the maximum feedrate possible, set by axis machine parameter "G00FEED". This feedrate will be applied while that key is kept pressed and the previous feedrate will be restored when that key is released.

Depending on the status of the general logic input "LATCHMAN", the movement will be carried out as follows:

- If the PLC sets this mark low, the axis will be jogged while pressing the corresponding Jog key.
- If the PLC sets this mark high, the axes will start moving from the moment the JOG key is pressed until the same is pressed again, or another JOG key is pressed. In this case, the movement will be transferred to that indicated by the new key.

The following cases are possible when working with "F" in mm/rev:

- The spindle is running.
- The spindle is stopped, but a spindle speed S has been selected.
- The spindle is stopped and no spindle speed S has been selected.

### **The spindle is running:**



The CNC moves the axes at the programmed F.

### **The spindle is stopped, but a spindle speed S has been selected:**

**S 0500**

The CNC calculates the feedrate F in mm/min for the theoretical S and moves the axis.

For example if "F 2.000" and "S 500":

 **% 115**

$$F \text{ (mm/min)} = F \text{ (mm/rev)} \times S \text{ (rpm)} = 2 \times 500 = 1000 \text{ mm/min.}$$

The axis moves at a feedrate of 1000 mm/min.



CNC 8055  
CNC 8055i

-TC- OPTION  
(SOFT: V16.1X)



**The spindle is stopped and no spindle speed S has been selected:**

S 0500



% 115

If F = 0, the CNC moves the axes in rapid.

If F is other than 0, the axes can only be moved by pressing the rapid key and an axis key. The CNC moves the axis in rapid.

If the axis to be jogged does not belong to the active plane, the movement is carried out in mm/minute; thus, it is not necessary to program an S at the spindle.

Also, if any axis of the plane is the Y axis, it is not necessary either to program the S for jog movements in any axis, regardless of whether it belongs to the plane or not.

This is especially interesting for auxiliary axes, center rests and tailstocks, because, in those cases, the S has no effect.

2.

OPERATING IN JOG MODE  
Jog movement

**FAGOR** 

CNC 8055  
CNC 8055i

.TC. OPTION  
(SOFT: V16.1X)

## 2.5.4 Path-jog

The "path jog" mode acts when the switch is in one of the continuous or incremental jog positions. This feature may be used to act upon the jog keys of an axis to move both axes of the plane at the same time for chamfering (straight sections) and rounding (curved sections). The CNC assumes as "Path jog" the keys associated with the X axis.



*This feature must be managed from the PLC. This feature is usually activated and deactivated by means of an external push-button or a key configured for that purpose, as well as the selection of the type of path.*

The next example uses the [O2] key to activate and deactivate the path-jog mode and the [O3] key to indicate the type of movement.

- Activate / deactivate the path-jog mode.

DFU B29 R561 = CPL M5054

- It selects the type of movement, straight section or arc section.

DFU B31 R561 = CPL M5053

While in jog mode and having selected path-jog, the CNC shows the following information:

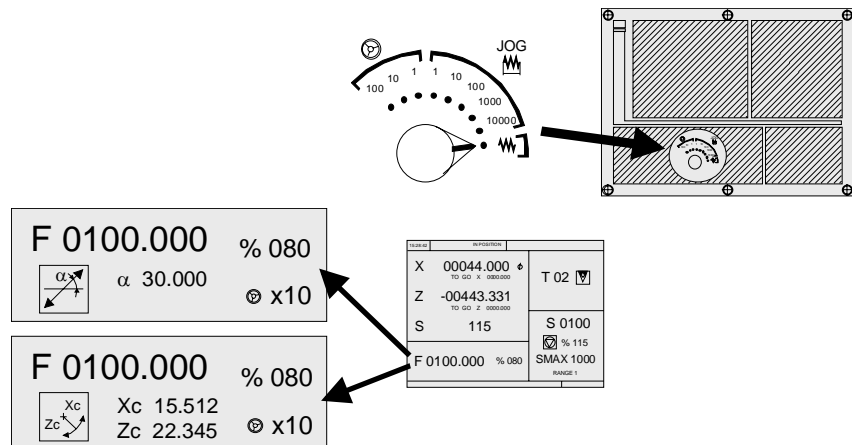

For a linear movement (top figure), the path angle must be defined and for an arc (bottom figure), the center coordinates must be indicated. To define these variables, press the [F] key and then one of these keys: [←] [→] [↑] [↓].



CNC 8055  
CNC 8055i

-TC- OPTION  
(SOFT: V16.1X)

## Operation in path-jog mode

The "path jog" mode is only available with the X axis keys. When pressing one of the keys associated with the X axis, the CNC behaves as follows:

Switch position	Path-jog	Type of movement
Continuous jog	OFF	Only the axis and in the indicated direction
	ON	Both axes in the indicated direction and along the indicated path
Incremental jog	OFF	Only the axis, the selected distance and in the indicated direction
	ON	Both axes, the selected distance and in the indicated direction, but along the indicated path
Handwheel		It ignores the keys.

The rest of the jog keys always work in the same way, whether "path jog" is on or off. The rest of the keys move only the axis and in the indicated direction.

The movements in path-jog may be aborted by pressing the [STOP] key or setting the jog switch to one of the handwheel positions.

### **Considerations about the jog movements**

This mode assumes as axis feedrate the one selected in jog mode and it will also be affected by the feedrate override switch. If F0 is selected, it assumes the one indicated by machine parameter "JOGFEED (P43)". This mode ignores the rapid jog key.

Path-jog movements respect the travel limits and the work zones.

2.

OPERATING IN JOG MODE

Jog movement



CNC 8055  
CNC 8055i

.TC- OPTION  
(SOFT: V16.1X)

## 2.5.5 Movement with an electronic handwheel

This option may be used to govern the movements of the machine using an electronic handwheel. To do that, turn the left switch to any of the handwheel positions.

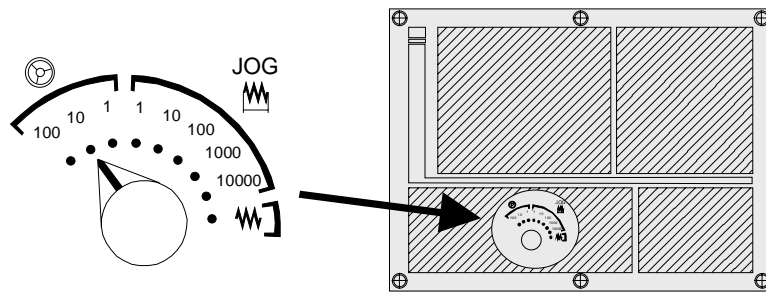

The positions available are 1, 10 and 100; they indicate the multiplying factor being applied besides the internal x4 to the feedback pulses supplied by the electronic handwheel.

Switch position	Distance per turn
1	0.100 mm or 0.0100 inches
10	1.000 mm or 0.1000 inches
100	10.000 mm or 1.0000 inches



*It may happen that depending on the turning speed and the selector switch position, the CNC be demanded a faster feedrate than the maximum allowed (axis machine parameter "G00FEED"). The CNC will move the axis the indicated distance but at the maximum feedrate allowed.*

### The machine has an electronic handwheel

Once the desired switch position has been selected, press one of the JOG keys for the axis to be jogged. The bottom of the screen shows the selected axis in small characters and next to the handwheel symbol.

When using a FAGOR handwheel with an axis selector button, the axis may be selected as follows:

- Push the button on the back of the handwheel. The CNC select the first axis and it highlights it.
- When pressing the button again, the CNC selects the next axis and so on in a rotary fashion.
- To deselect the axis, hold the button pressed for more than 2 seconds.

Once the axis has been selected, it will move as the handwheel is being turned and in the direction indicated by it.

### The machine has two or three electronic handwheels

Each axis will move as the corresponding handwheel is being turned according to the switch position and in the direction indicated by it.

When the machine has a general handwheel and individual handwheels (associated with each axis of the machine), the individual handwheels have the highest priority; i.e. when moving an individual handwheel, the CNC will ignore the general handwheel.

# 2.

OPERATING IN JOG MODE  
Jog movement



CNC 8055  
CNC 8055i

-TC- OPTION  
(SOFT: V16.1X)

## 2.5.6 Feed handwheel

Usually, when making a part for the first time, the machine feedrate is controlled by means of the feedrate override switch.

From this version on, it is also possible to use the machine handwheels to control that feedrate. This way, the machining feedrate will depend on how fast the handwheel is turned.



*This feature must be managed from the PLC. This feature is usually activated and deactivated by means of an external push-button or a key configured for that purpose.*

The following CNC variables return the number of pulses the handwheel has turned.

HANPF	Provides the number of pulses of the 1st handwheel.
HANPS	Provides the number of pulses of the 2nd handwheel.
HANPT	Provides the number of pulses of the 3rd handwheel.
HANPFO	Provides the number of pulses of the 4th handwheel.

2.

OPERATING IN JOG MODE  
Jog movement



CNC 8055  
CNC 8055i

.TC- OPTION  
(SOFT: V16.1X)

## 2.5.7 Path-handwheel

The "path handwheel" mode acts when the switch is in one of the handwheel positions. With this feature, it is possible to jog two axes of the plane at the same time along a linear path (chamfer) or circular path (rounding) with a single handwheel. The CNC assumes as the path handwheel the general handwheel or, when this one is missing, the one associated with the X axis.



*This feature must be managed from the PLC. This feature is usually activated and deactivated by means of an external push-button or a key configured for that purpose, as well as the selection of the type of path.*

The next example uses the [O2] key to activate and deactivate the path-handwheel mode and the [O3] key to indicate the type of movement.

- Activate / deactivate the path-handwheel mode.

DFU B29 R561 = CPL M5054

- It selects the type of movement, straight section or arc section.

DFU B31 R561 = CPL M5053

While in handwheel mode and having selected path-handwheel, the CNC shows the following information:

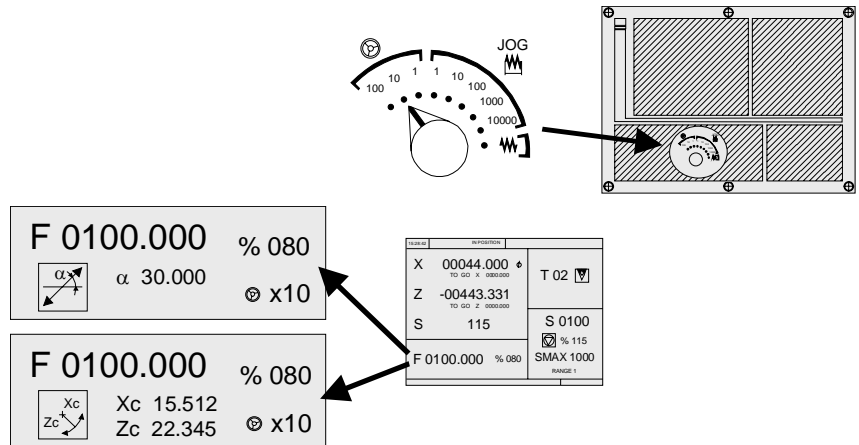

For a linear movement (top figure), the path angle must be defined and for an arc (bottom figure), the center coordinates must be indicated. To define these variables, press the [F] key and then one of these keys: [←] [→] [↑] [↓].

### Operation in path-handwheel mode

When selecting the path handwheel mode, the CNC behaves as follows.

- If there is a general handwheel, it will be the one working in path handwheel mode. The individual handwheels, if any, will remain associated with the corresponding axes.
- If there is no general handwheel, the individual handwheel associated with the X axis then works in path-handwheel mode.

The movements in path-handwheel may be aborted by pressing the [STOP] key or setting the jog switch to one of the continuous or incremental positions.

# 2.

OPERATING IN JOG MODE  
Jog movement



CNC 8055  
CNC 8055i

-TC- OPTION  
(SOFT: V16.1X)

## 2.6 Tool control

The standard screen of the TC mode offers the following tool data.

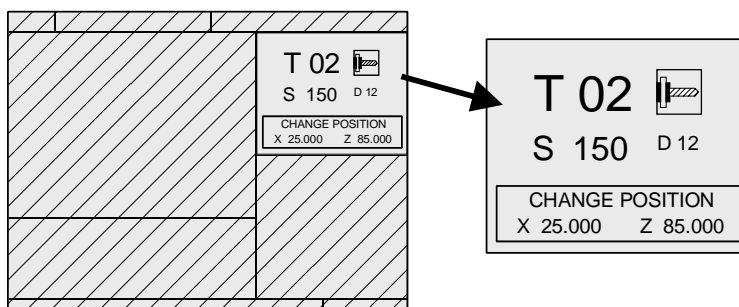

This window displays the following information:

- In large characters, the tool "T" number currently selected and a graphic representation of its tip.
- The "D" offset number associated with the tool.
- The "S" rpm that are selected for the live tool. This value is only shown when a live tool has been selected.
- The position values of the tool change point. The CNC does not show this window when text 47 of program 999997 has not been defined.

To select another tool, follow these steps:

1. Press the [T] key.  
The CNC highlights the tool number.
2. Key in the number of the tool to be selected.  
To quit the preset selection mode, press [ESC].
3. Press [START] for the CNC to select the new tool.  
The CNC will manage the tool change. Once the new tool has been selected, the CNC refreshes the graphic representation for the location code (shape) associated with the new tool.

Another offset may be assigned to the tool temporarily without modifying the one associated with it.

1. To access the "D" field, press [T] and [↓].
2. Key in the number of the desired tool offset and press [START].  
The CNC temporarily assumes the new offset for the current tool. The internal table is not modified, the tool's associated offset is still the one assigned to it when it was calibrated.

2.

OPERATING IN JOG MODE  
Tool control

FAGOR 

CNC 8055  
CNC 8055i

.TC- OPTION  
(SOFT: V16.1X)

## 2.6.1 Tool change

Depending on the type of tool changer, the following options are possible:

- Machine with automatic tool changer.
- Machine with manual tool changer.

In either case, the CNC acts as follows:

- The CNC executes the subroutine associated with the tool change (general machine parameter P60 "TOOLSUB").
- The CNC sends to the PLC all the necessary information for it to manage the tool change.
- The CNC assumes the new tool values (offsets, geometry, etc).

### Example of how to manage a manual tool changer.

- Subroutine 55 is defined as the subroutine associated with the tools.

General machine parameter P60 "TOOLSUB" = 55.

The subroutine associated with the tools may contain the following information:

```
( SUB 55 )
( P100 = NBTOOL )
; Assigns the requested tool number to P100.
( P101 = MS3 )
; If spindle counterclockwise P102=1.
G0 G53... XP?? ZP??
; Movement to the tool change point.
M5
; Spindle stop.
( MSG "SELECT T?P100 AND PRESS START" )
; Message to select the tool change.
M0
; Stop the program stop and wait for START to be pressed.
( MSG " " " " )
; Deletes previous message.
( IF P102 EQ 1 GOTO N10 )
; Restores the spindle turning direction.
( IF P101 EQ 0 RET )
M3
( RET )
N10 M4
( RET )
```

- The tool is selected after executing the subroutine.

General machine parameter P71 "TAFTERS" = YES.

- The movement to the change point only takes place when executing an operation or cycle of the TC mode.

When a cycle has been selected (CYCEXE other than 0)

The program is being executed (OPMODA bit 0 = 1).

- Once the subroutine is completed, the CNC executes function T??, sends to the PLC all the necessary information for it to manage the tool change and assumes the new tool values (offsets, geometry, etc.).

2.

OPERATING IN JOG MODE  
Tool control



CNC 8055  
CNC 8055i

-TC- OPTION  
(SOFT: V16.1X)



## 2.6.2 Variable tool change point

If the manufacturer so wishes, he can let the user define the tool change point every time. Obviously, this feature depends on the type of machine and type of tool changer.

This feature may be used to change the tool next to the part, thus avoiding movements to a tool change point located far away from it.

To do this:

- Define the text 47 of program 999997 so the CNC requests the X, Z coordinates of the tool change point.

For example: ;47 \$CHANGE POSITION

These coordinates must be referred to machine zero point, so the zero offsets do not affect the tool change point. Therefore, the CNC can show, next to the X, Z coordinates and in small characters, the coordinates of the axes referred to machine reference zero.

- Text 33 of program 999997 must be defined so the CNC shows the coordinates of the axes referred to machine reference zero.

For example: ;33 \$MACHINE ZERO

Since the operator can change the tool change point at any time, the subroutine associated with the tools must consider those values. Arithmetic parameters P290 and P291 contain the values set by the operator as tool change position in X and Z respectively.

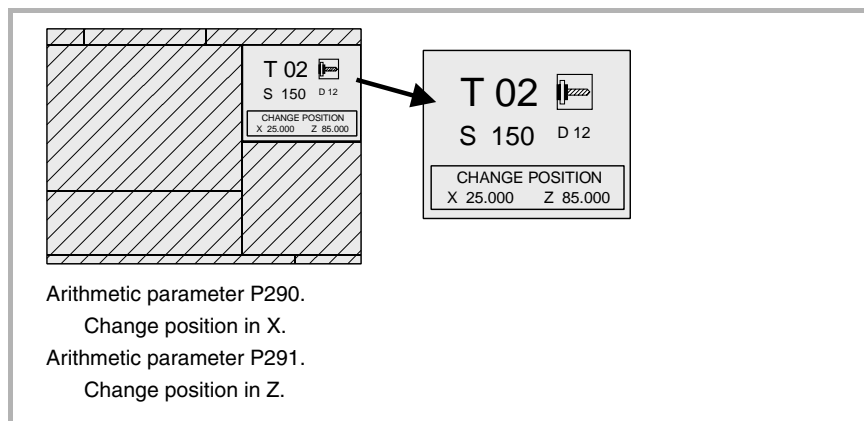

In subroutine 55 of the previous section, the line setting the movement to the tool change point must be modified:

Where it says:

G0 G53 XP??? ZP??? ; Movement to the tool change point.

It must say:

G0 G53 XP290 ZP291 ;User-defined movement to the change point.

### Define the coordinates of the tool change point (X, Z)

1. Press the [T] key to select the «T» field.
2. Then press the [X] or [Z] key of the desired axis or the [←] [→] [↑] [↓] keys.
3. After placing the cursor on the coordinates of the axis to be defined, define the desired values.

2.

OPERATING IN JOG MODE

Tool control

FAGOR 

CNC 8055  
CNC 8055i

.TC- OPTION  
(SOFT: V16.1X)

## 2.

### OPERATING IN JOG MODE

Tool control

After placing the cursor on the coordinates of the axes to be defined, the value is entered in one of the following ways.

- Entering the value manually. Key in the desired value and press [ENTER].
- Assign the current machine position.

Jog the axis with the handwheel or the JOG keys up to the desired point. Press [RECALL] so the selected data assumes the value shown in the top right window and press [ENTER].

The top right window shows the tool position at all times.



CNC 8055  
CNC 8055i

.TC. OPTION  
(SOFT: V16.1x)

## 2.7 Tool calibration



This mode may be used to define the tools and calibrate them. The tools may be calibrated with or without using a probe.

This mode is also available while executing a program and during tool inspection.

The calibration mode can have several editing levels. The second level will only be available when using a table-top probe installed on the machine.



Each level has its own screen and the main window of the cycle indicates, with tabs, the available levels and which one is selected. To change levels, use the [LEVEL CYCLE] key or the [page up] and [page down] keys to scroll up and down through the various levels.

### What can be done in tool calibration mode

The data that may be modified from the calibration cycles depend on when this mode is accessed. The following limitations must be borne in mind when accessing the tool calibration mode with a program in execution or from tool inspection.

#### **Without a program in execution nor in tool inspection.**

When editing the active tool, it is possible:

- Modify all the data.
- Change the active tool (T ?? + [START]).

When NOT editing the active tool, it is possible:

- Modify all the data except the part dimensions.
- Change the active tool (T ?? + [START]).

#### **Program in execution or interrupted.**

When editing the active tool, it is possible:

- To modify the I and K data.
- Select another tool (T?? + [RECALL]) and modify the I and K data.

When NOT editing the active tool, it is possible:

- To modify the I, K and D data.
- Select another tool (T?? + [RECALL]) and modify the I, K and D data.

#### **Program in tool inspection.**

When editing the active tool, it is possible:

- To modify the I and K data.
- Select another tool (T?? + [RECALL]) and modify the I and K data.
- Change the active tool (T ?? + [START]).

When NOT editing the active tool, it is possible:

- To modify the I, K and D data.
- Select another tool (T?? + [RECALL]) and modify the I, K and D data.
- Change the active tool (T ?? + [START]).

2.

OPERATING IN JOG MODE  
Tool calibration



CNC 8055  
CNC 8055i

.TC- OPTION  
(SOFT: V16.1X)

## 2.7.1 Define the tool in the tool table (level 1)

When accessing this level, the CNC shows the following screen.

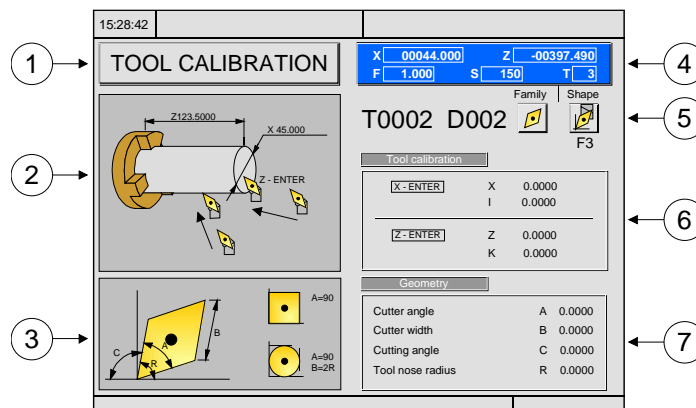

1. Indicating the selected work mode: "Tool calibration".
2. Help graphics for calibrating the tool.
3. Help graphics for defining tool geometry.
4. Current machine status.  
Real X Z coordinates, real axis feedrate F, real spindle speed S and currently selected tool T.
5. Tool number, tool offset number, location code (shape) and tool family.
6. Length values defined for this tool.
7. Values for the geometry of the tool.

### Define the tool data

Proceed as follows to define a tool in the tool table:

#### Select the number of the tool to be defined.

1. Press the [T] key to select the "T" field.
2. Key in the desired tool number and press [RECALL].

If the tool is defined, the CNC will show the values stored in the table. If the tool is not defined, the CNC assigns an offset with the same number to it and all the data is reset to 0.

#### Select the number of the offset tool to be associated with this tool.

1. The "D" field must be selected. If it is not, use the [↓] key.
2. Key in the desired offset number to be associated with the tool and press [ENTER].

#### Define the tool dimensions.

The data for the tool is the following.

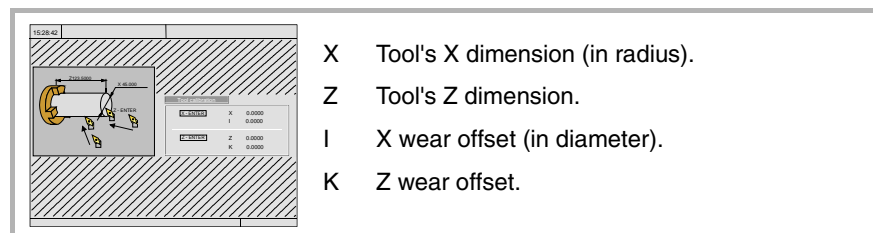

Even if the tool dimensions are known, it is recommended to measure it. See **"2.7.2 Manual tool calibration with/without a probe (level 1)."** on page 35.

Once it is measured, the CNC updates the X, Z fields and sets the I and K data to 0.

To define these values, select the corresponding field with the [←] [→] [↑] [↓] keys, key in the desired value and press [ENTER].

**Defining the tool type.**



Place the cursor over the icon for tool type and press the two-color key. The available tool types are:

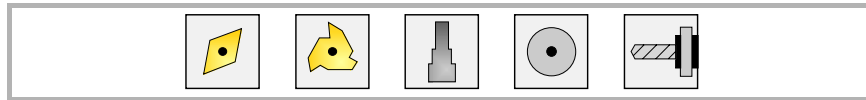

**Define the location code of the tool.**



Place the cursor over the icon for tool type and press the two-color key. The available tool types are:

**2.**

OPERATING IN JOG MODE  
Tool calibration



CNC 8055  
CNC 8055i

.TC- OPTION  
(SOFT: V16.1X)

Define the rest of the data related to the tool.

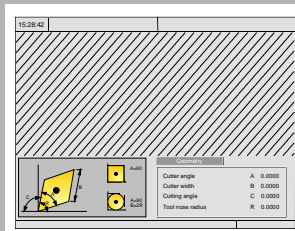

Cutter angle	A	0.0000
Cutter width	B	0.0000
Cutting angle	C	0.0000
Tool nose radius	R	0.0000

- A Cutter angle.
- B Cutter width.
- C Cutting angle.
- R Tool radius.

The right window shows the tool geometry values and the left window shows help graphics. To define one of these values, select the corresponding field, key in the desired value and press [ENTER].

2.

OPERATING IN JOG MODE  
Tool calibration



CNC 8055  
CNC 8055i

.TC- OPTION  
(SOFT: V16.1X)

## 2.7.2 Manual tool calibration with/without a probe (level 1).

Before measuring the tool, it must be defined in the tool table. See "2.7.1 Define the tool in the tool table (level 1)" on page 32.

There are 2 ways to calibrate a tool.

- When having a tool setting table.
 

Use the window that shows the tool dimensions to define that data. Define the X Z dimensions and the I, K wear.
- When not having any measuring device.
 

The measurements will be taken with the CNC. Use the window for tool calibration.

# 2.

OPERATING IN JOG MODE  
Tool calibration

### Manual tool calibration with/without a probe



In the manual tool calibration cycle, it is possible to calibrate the tool using a master part or a probe. The type of calibration is defined with the following icon: Use the two-color key to select one of them.

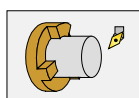

Tool calibration using a master part of known dimensions.

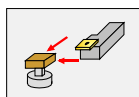

Tool calibration using a probe.

When using a probe for calibrating, one must define the approach distance " $\Delta$ ", the approach feedrate "F" and the probe side to be probed. If " $\Delta$ " not defined, it will take this data from general machine parameter "PRBMOVE". Likewise, if "F" not defined, it will take this data from axis machine parameter "PRBFEEED".

Once probing is completed, the screen updates the data.

### Define the tool length or modify the length offsets

This window shows the dimensions assigned to the selected tool.

	X	Tool's X dimension (in radius).
	Z	Tool's Z dimension.
	I	X wear offset (in diameter).
	K	Z wear offset.

The X and Z data indicate the tool dimensions. I and K indicate the offset the CNC must apply to compensate for tool wear.

The CNC adds the value of the "I" offset to X length and the value of the "K" offset to the Z length to calculate the real dimensions (R+I, L+K) that must be used.

- Every time the X length or the Z length value is defined, the CNC sets the "I" and "K" fields to 0 respectively.
- The "I" and "K" data are accumulative. In other words, if the "I" has a value of 0.20 and the value of 0.05 is entered, the CNC assigns the value of 0.25 (0,20+0,05) to the "I" field.
- If one sets I=0 or K=0, they are both reset to 0.

To change one of these values, select the corresponding field, key in the desired value and press [ENTER].



CNC 8055  
CNC 8055i

.TC- OPTION  
(SOFT: V16.1X)

# 2.

**OPERATING IN JOG MODE**  
Tool calibration

## **Tool calibration**

---

Place a part of known dimensions in the spindle and define its dimensions in the left window.

To measure the tool, the tool must be selected on the machine. If it is not, press the [T] key, key in the desired number of the tool to be calibrated and press [START].

Measuring the tool.

1. Approach the tool to the part, touch it with it along the X axis and press [X] + [ENTER].
2. Approach the tool to the part, touch it with it along the Z axis and press [Z] + [ENTER].

The tool has been calibrated. The CNC updates the X, Z data and sets the I and K to 0. The actual tool length is (X+I) and (Z+K); the "I" must be given in diameter.

## **Modifying the tool data while executing a program**

---

It is possible to modifying the tool values (dimensions and geometry) without interrupting the execution of a program.



To do that, press the tool calibration key. The CNC will show the tool calibration screen with all the data for the active tool and it will allow modifying its data or of any other tool.

To exit this screen, press [ESC].



**CNC 8055**  
**CNC 8055i**

-TC- OPTION  
(SOFT: V16.1X)



### 2.7.3 Tool calibration with a probe (level 2)

This calibration level requires the purchase of the right software options purchased and the use of a table-top probe.

Once the cycle has concluded, it updates the tool offset table with the length value X Z of the tool offset that is currently selected. The I and K values are updated to 0.

#### **Defining the cycle data**

---

The following data must be defined.

- Tool number (T) and tool offset (D) to be calibrated.
- Safety distance (Ds), for the probe approach.
- Probing feedrate (F).

#### **Probe position.**

In this zone, one must indicate whether the cycle assumes the probe position defined in the machine parameters or the position defined in this zone. To select one of them, use the cursor to select the "Machine parameters / Programmable parameters" field and press the two-color key.

**2.****OPERATING IN JOG MODE**  
Tool calibration**FAGOR** **CNC 8055**  
**CNC 8055i**-TC- OPTION  
(SOFT: V16.1X)

## Tool wear measurement

In this cycle, besides calibrating a tool, it is also possible to measure tool wear.

Using the tool wear measuring operation, the user can define the maximum tool wear value. After several tool wear measuring probing operations, the wear will increase and when it exceeds the set maximum value, the tool will be rejected.

To perform this cycle it is necessary to have a table-top probe, installed in a fixed position on the machine and with its faces parallel to axes X, Y, Z.

When accessing this calibration level, the CNC shows the following screen:

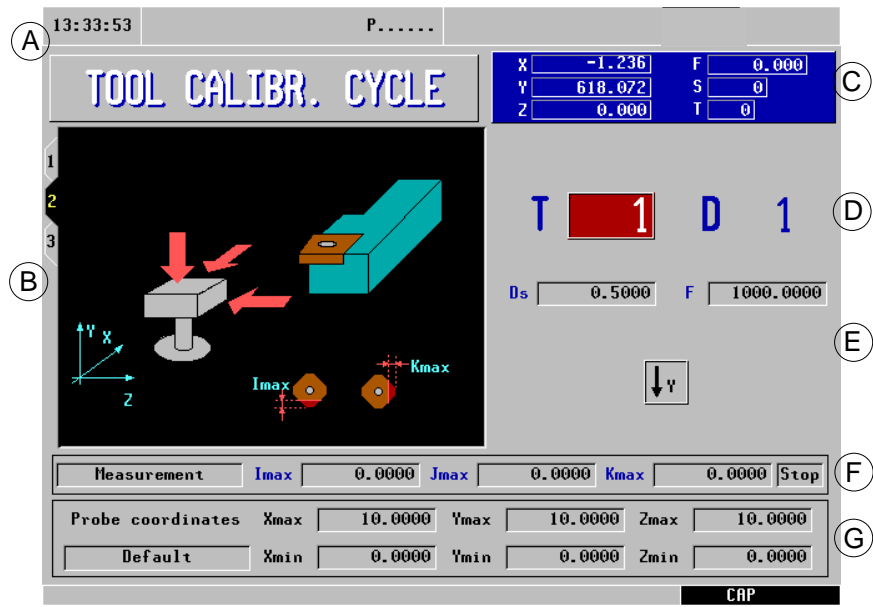

- A. Indicating the selected work mode.
- B. Help graphics for calibrating the tool.
- C. Current machine status.
- D. Tool number and associated offset.
- E. Calibration data.
- F. Type of operation and wear values.
- G. Probe position.

This level may be saved as part of a part-program using the [P.PROG] key or executed using the [START] key.

**2.**  
OPERATING IN JOG MODE  
Tool calibration



CNC 8055  
CNC 8055i

-TC- OPTION  
(SOFT: V16.1X)

## Defining the cycle data

The following data must be defined. All the data will not always be available; the cycle will show the necessary data depending on the selected operation.

- Safety distance (Ds), for the probe approach.
- Probing feedrate (F).
- Icon to define the Y axis moving direction.
- Type of operation:

The cycle may be used to do a measurement or a calibration. To select the desired operation, position the cursor on the "Measurement / Calibration" field and press the two-color key. To take a measurement, define the following data.

lmax	Maximum length wear allowed on the X axis.
Kmax	Maximum length wear allowed on the Z axis.
Jmax	Maximum length wear allowed on the Y axis.
Stop / Chg	Cycle behavior when exceeding the maximum wear allowed. Use the two-color key to select one of them.

The "Stop" option interrupts the execution for the user to select another tool. With the "Chg" option, the cycle replaces the tool with another one of the same family.

Measuring is only available when purchasing the software option: "Tool life monitoring".

- Probe position.

In this zone, one must indicate whether the cycle assumes the probe position defined in the machine parameters or the position defined in this zone. To select one of them, use the cursor to select the "Machine parameters / Programmable parameters" field and press the two-color key.

Machine parameters: The cycle assumes the probe position defined in the machine parameters.

Programmed parameters: The cycle assumes the probe position defined in the cycle (Xmax, Xmin, Ymax, Ymin, Zmax, Zmin).

## Actions after finishing the tool wear measuring cycle

To activate the rejected tool, either because it has been replaced with another one or not, the CNC offers the following options:

1. Go into the tool table in ISO mode and delete the real life of that tool.
2. Go into the tool table in ISO mode and write the desired value for the real life of that tool.

In this case, to activate the tool the real life value must be smaller than the nominal life value. Otherwise, the tool will be shown as expired (status = E).

2.

OPERATING IN JOG MODE  
Tool calibration



CNC 8055  
CNC 8055i

.TC- OPTION  
(SOFT: V16.1X)

## 2.7.4 Probe calibration (level 3)

This calibration level requires the purchase of the right software options purchased and the use of a table-top probe.

This cycle may be used to calibrate the sides of the table-top probe, installed in a fixed position of the machine whose sides parallel to the X and Z axes. The probe position must be defined in the corresponding machine parameters (PRB\*MIN, PRB\*MAX).

To execute the cycle, a master tool of known dimensions will be used whose values have been previously entered in the selected offset.

The data obtained in the calibration are updated directly in machine parameters PRB\*MIN and PRB\*MAX. To do this, program P99998 must be set as OEM.

### Defining the cycle data

The following data must be defined.

- Tool number (T) and tool offset (D) used to define the dimensions of the master part.
- Safety distance (Ds), for the probe approach.
- Probing feedrate (F).

#### **Probe position.**

In this zone, one must indicate whether the cycle assumes the probe position defined in the machine parameters or the position defined in this zone. To select one of them, use the cursor to select the "Machine parameters / Programmable parameters" field and press the two-color key.

2.

OPERATING IN JOG MODE  
Tool calibration



CNC 8055  
CNC 8055i

.TC- OPTION  
(SOFT: V16.1X)

## 2.8 Live tool

When a live tool has been selected, the standard screen of the TC mode offers the following information:

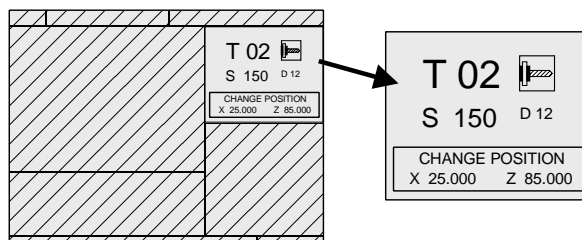

Proceed as follows to select the "S" rpm of the live tool:

1. Press the [T] key to select the "T" field.
2. Press the [S] key or the [↓] key to select the "S" rpm of the live tool.
3. Entering the value manually. Key in the desired value and press [ENTER].

The keys for the live tool are:

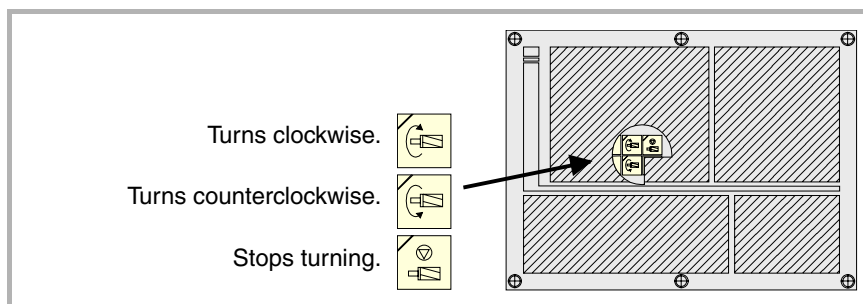



### Considerations about the live tool

The following considerations must be borne in mind when the machine has a live tool:

- Set one of general parameters P0 to P9 with a value of 13.
- The location code (shape) of the live tool must be 10, 20 or 30.
- The PLC must manage the keys for the live tool.

Every time one of these keys is pressed, the CNC updates the corresponding register bit.

-  bit 7 of register 561 (B7 R561)
-  bit 3 of register 562 (B3 R562)
-  bit 5 of register 562 (B5 R562)

2.

OPERATING IN JOG MODE  
Live tool

**FAGOR** 

CNC 8055  
CNC 8055i

.TC- OPTION  
(SOFT: V16.1X)

### Example of a PLC program to manage the live tool

Here is an example of the portion of the PLC program that must manage the live tool:

( ) = CNCRD (TOOL, R101, M1)

Assigns the number of the active tool to register R101.

= CNCRD (TOF R101, R102, M1)

Loads register R102 with the location code of the active tool.

CPS R102 EQ 10 OR CPS R102 EQ 20 OR CPS R102 EQ 30 = M2

If the active tool is a live tool (if its location code is 10, 20 or 30), it activates the M2 mark.

CUSTOM AND (DFU B7R561 OR DFD M2) = CNCEX1 (M45 S0, M1)

If while the TC (CUSTOM=1) mode is selected, the "Stop live tool" key is pressed (DFU B7R561) or the live tool is de-selected (DFD M2).

The PLC "tells" the CNC to execute block M45 S0 (stops the live tool).

CUSTOM AND M2 AND DFU B3R562 = CNCRD (LIVRPM, R117, M1) = CNCWR (R117, GUP100, M1) = CNCEX1 (M45 SP100, M1)

If in TC (CUSTOM=1) mode, a live tool is selected (M2) and the "live tool clockwise" key is pressed (DFU B3R562).

The PLC reads in R117 the rpm currently selected for the live tool (LIVRPM) and assigns them to general parameter P100.

Finally, the PLC "tells" the CNC to execute block M45 SP100 (live tool clockwise at the selected rpm).

CUSTOM AND M2 AND DFU B5R562 = CNCRD (LIVRPM, R117, M1) = CNCWR (R117, GUP100, M1) = CNCEX1 (M45 S-P100, M1)

If in TC (CUSTOM=1) mode, a live tool is selected (M2) and the "live tool counterclockwise" key is pressed (DFU B5R562).

The PLC reads in R117 the rpm currently selected for the live tool (LIVRPM) and assigns them to general parameter P100.

Finally, the PLC "tells" the CNC to execute block M45 S-P100 (live tool counterclockwise at the selected rpm).

# 2.

OPERATING IN JOG MODE  
Live tool



CNC 8055  
CNC 8055i

-TC- OPTION  
(SOFT: V16.1X)

## 2.9 Spindle control

The standard screen of the TC mode has a window that shows the following spindle related data.

Since it is possible to work with the spindle in rpm, at CSS or in orientation mode, the information shown by that window will be different in each case.

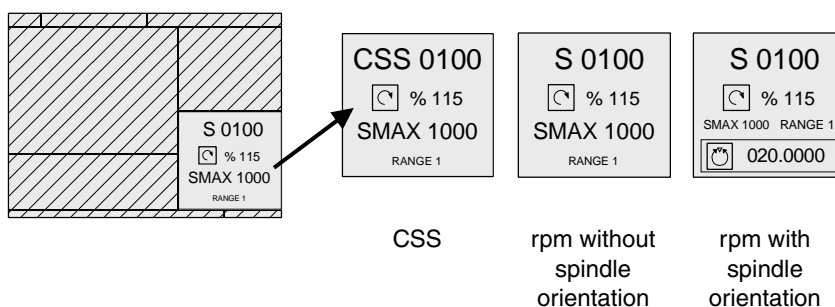

To switch from one mode to the other, press the key:

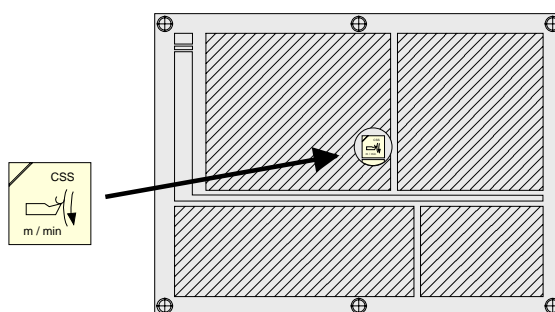

On CNC power-up and after the keystroke sequence [SHIFT] [RESET], the CNC selects the rpm mode. When working at constant surface speed (CSS), the light of the [CSS] key is on.

2.

OPERATING IN JOG MODE  
Spindle control

FAGOR 

CNC 8055  
CNC 8055i

.TC- OPTION  
(SOFT: V16.1X)

## 2.9.1 Spindle in rpm

The CNC displays the following information.

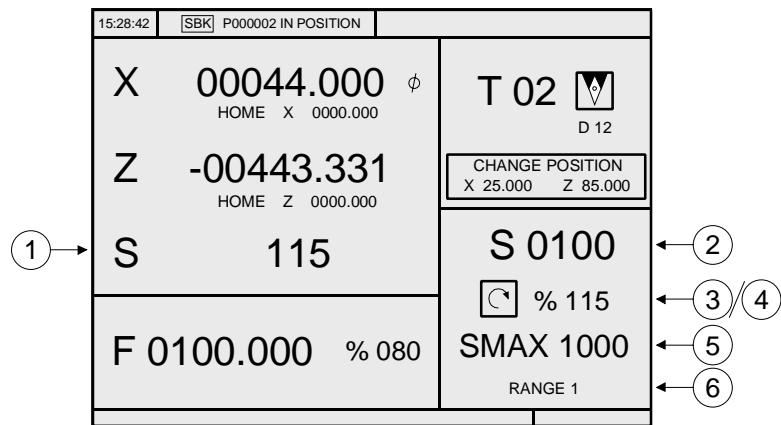

1. Real spindle speed in rpm.

2. Theoretical spindle speed in rpm.

To select another speed, press the [S] key. The CNC highlights the current value.

Enter the new value and press [START]. The CNC assumes that value and refreshes the real spindle speed.

3. Spindle status.



Spindle clockwise



Spindle counterclockwise



Spindle stopped

To modify the spindle status, press the following keys:

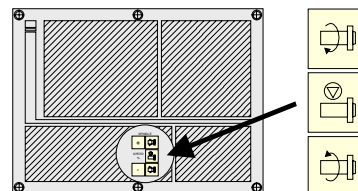

4. Percentage of the theoretical spindle speed being applied.

To modify the percentage (%), press the following keys.

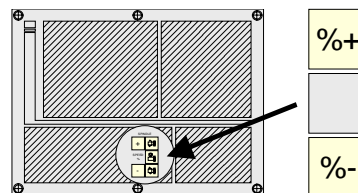

5. Maximum spindle speed in rpm.

To select another speed, press the [S] key twice. The CNC highlights the current value. Enter the new value and press [ENTER]. The CNC assumes this value and does not allow the spindle to exceed these rpm.

The maximum spindle speed is saved in the MDISL variable. This variable is updated (refreshed) changing the SMAX value and when programming function "G92 S" via ISO.



6. Spindle gear currently selected.

This value cannot be changed when using an automatic gear change.

When not using an automatic tool changer, press the [S] key and then use the [↓] key to highlight the current value. Enter the gear number to be selected and press [ENTER] or [START].



*When the machine does not use spindle gears, this message makes no sense. That is why the CNC does not show this message when text 28 of program 999997 has not been defined.*



**OPERATING IN JOG MODE**  
Spindle control



CNC 8055  
CNC 8055i

.TC- OPTION  
(SOFT: V16.1X)

## 2.9.2 Spindle in constant surface speed mode

In constant surface speed mode, the user sets the tangential speed that must always be kept between the tool tip and the part. Therefore, the spindle rpm depend on the position of the tool tip with respect to the rotation axis. Thus, if the tool tip gets away from the rotation axis, the spindle slows down and if it gets closer, it speeds up.

The CNC displays the following information.

**2.**  
OPERATING IN JOG MODE  
Spindle control

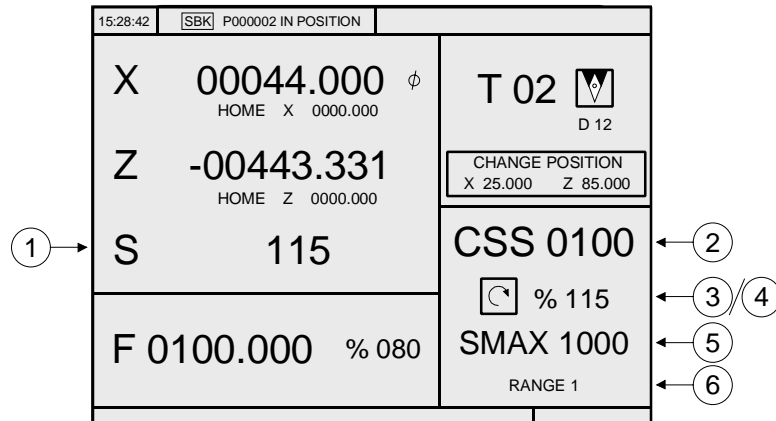

1. Real spindle speed in rpm.
2. Theoretical constant surface speed. This speed is defined in meters/min or feet/min.  
To select another speed, press the [S] key. The CNC highlights the current value. Enter the new value and press [START]. The CNC assumes this value and if the spindle is turning, it updates the real spindle speed.
3. Spindle status.

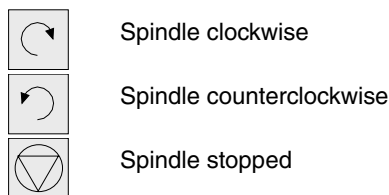

To modify the spindle status, press the following keys:

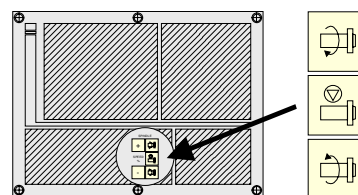

4. Percentage of the theoretical spindle speed being applied.  
To modify the percentage (%), press the following keys.

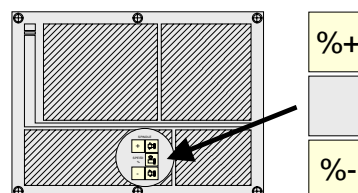

5. Maximum spindle speed in rpm.  
To select another speed, press the [S] key twice. The CNC highlights the current value. Enter the new value and press [ENTER]. The CNC assumes this value and does not allow the spindle to exceed these rpm.  
The maximum spindle speed is saved in the MDISL variable. This variable is updated (refreshed) changing the SMAX value and when programming function "G92 S" via ISO.



CNC 8055  
CNC 8055i

-TC- OPTION  
(SOFT: V16.1x)

6. Spindle gear currently selected.

This value cannot be changed when using an automatic gear change.

When not using an automatic tool changer, press the [S] key and then use the [↓] key to highlight the current value. Enter the gear number to be selected and press [ENTER] or [START].



*When the machine does not use spindle gears, this message makes no sense. That is why the CNC does not show this message when text 28 of program 999997 has not been defined.*

2.

OPERATING IN JOG MODE  
Spindle control

**Working at constant surface speed mode**

When selecting the constant surface speed mode, the CNC assumes the spindle gear (range) that is currently selected. The following cases may occur in this mode, when selecting a new constant surface speed value:

- The spindle is stopped.  
The CNC selects the new speed, but it does not apply it until the starts turning.
- The spindle is running.  
The CNC, depending on the position of the axis, calculates and turns the spindle at the corresponding rpm so the constant surface speed is the one defined.

The following cases may occur when moving the axes when working at constant surface speed:

- The spindle is running.  
The CNC moves the axes at the programmed F.  
As the X axis moves, the CNC adapts the spindle speed (rpm) to maintain the selected constant speed. Thus, if the tool tip gets away from the rotation axis, the spindle slows down and if it gets closer, it speeds up.  
The CNC limits the spindle rpm to the maximum speed set by "SMAX".
- The spindle is stopped, but a spindle speed S has been selected.  
The CNC calculates the feedrate F in mm/min for the last programmed S and moves the axis.  
For example if «F 2.000» and «S 500»:  
$$\text{Feedrate} = F (\text{mm/rev}) \times S (\text{rev/min}) = 2 \times 500 = 1000 \text{ mm/min.}$$
  
The axis moves at a feedrate of 1000 mm/min.
- The spindle is stopped and no spindle speed S has been selected.  
If F = 0, the CNC moves the axes in rapid.



If F is other than 0, the axes can only be moved by pressing the rapid key and an axis key. The CNC moves the axis in rapid.



CNC 8055  
CNC 8055i

.TC- OPTION  
(SOFT: V16.1X)

## 2.9.3 Spindle orientation

When using spindle orientation (general machine parameter REFEED1 (P34) other than 0), the CNC shows the following information.

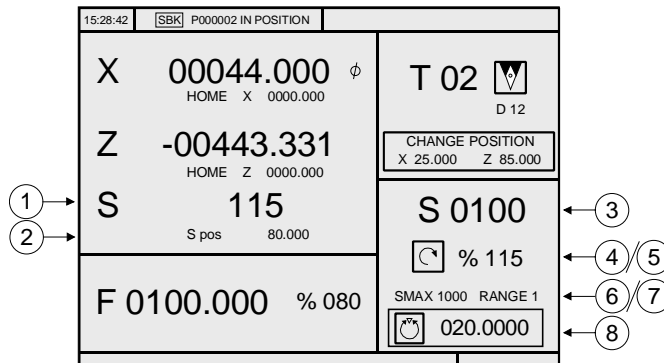

1. Real spindle speed in rpm.
2. Spindle angular position in degrees.

This information is shown when working in spindle orientation mode. When switching to RPM mode, it only shows the actual (real) spindle speed.

3. Theoretical spindle speed in rpm.

To select another speed, press the [S] key. The CNC highlights the current value. Enter the new value and press [START]. The CNC assumes that value and refreshes the real spindle speed.

4. Spindle status.



Spindle clockwise



Spindle counterclockwise



Spindle stopped

When working in spindle orientation mode, it always shows the "spindle stopped" symbol.

5. Percentage of the theoretical spindle speed being applied.

The CNC does not apply this factor when working in spindle orientation mode. It only applies it when working in RPM mode.

To modify the percentage (%), press the following keys.

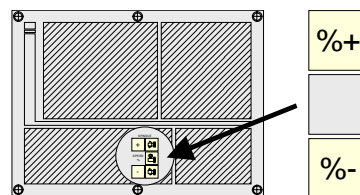

6. Maximum spindle speed in rpm.

To select another speed, press the [S] key twice. The CNC highlights the current value. Enter the new value and press [ENTER]. The CNC assumes this value and does not allow the spindle to exceed these rpm.

The maximum spindle speed is saved in the MDISL variable. This variable is updated (refreshed) changing the SMAX value and when programming function "G92 S" via ISO.

7. Spindle gear currently selected.

To select another gear, when not using an automatic tool changer, press the [S] key and then use the [↓] key until the current value is highlighted.

Enter the gear number to be selected and press [ENTER] or [START].



*When the machine does not use spindle gears, this message makes no sense. That is why the CNC does not show this message when text 28 of program 999997 has not been defined.*

8. Spindle angular increment when working in spindle orientation mode.

To select another value, press the [S] key three times. The CNC highlights the current value. Enter the new value and press [ENTER].

2.

OPERATING IN JOG MODE  
Spindle control

**Working with spindle orientation**

When having spindle orientation, the CNC uses the same screen when working in RPM mode and when working in spindle orientation mode.

**RPM mode.**

Press one of these three keys to select this mode. The screen will not show the angular position of the spindle.

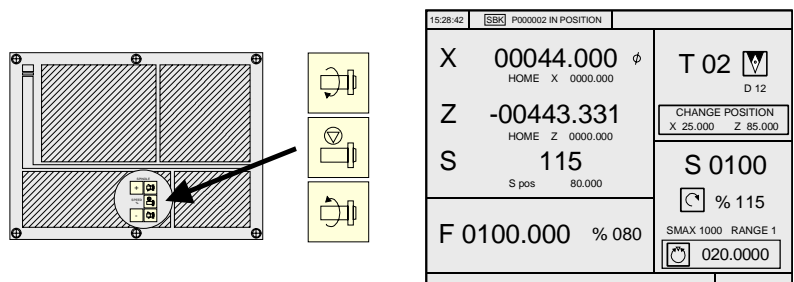

**Spindle orientation mode**

Press the key for spindle orientation to select this mode:

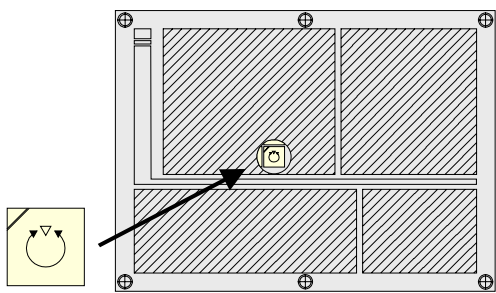

The spindle will stop (if it was turning), it then searches home and finally positions at the angular position indicated on the lower right side of the screen (at 20° in the upper figure).

Every time the spindle orientation key is pressed, the spindle position increments in that value (20° in the upper figure).



CNC 8055  
CNC 8055i

.TC- OPTION  
(SOFT: V16.1X)

## 2.10 Controlling the external devices

With this CNC, it is possible to activate and deactivate, via keyboard, up to 6 external devices, for example, the coolant.

The machine manufacturer must use the PLC program to activate and deactivate the devices. The CNC will inform the PLC about the status of each key. The corresponding register bit will be set to 1 when the key is pressed and 0 when it is not pressed.

The register bit for each key is:

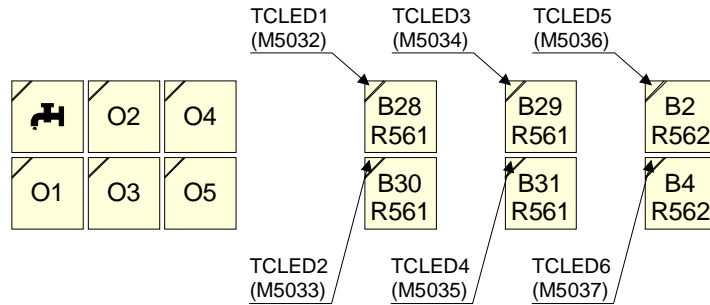

The status of the lamp of each key must be controlled by the machine manufacturer through the PLC program using the input variables TCLED\* indicated in the figure.

Examples:

Coolant control:

DFU B28R561 = CPL TCLED1 = CPL O33

Tailstock control (O1). A number of conditions must be met for activating or deactivating the tailstock, such as spindle stopped, etc.

DFU B30R561 AND (Rest of conditions) = CPL TCLED2 = CPL O34

# 2.

OPERATING IN JOG MODE  
Controlling the external devices



CNC 8055  
CNC 8055i

.TC- OPTION  
(SOFT: V16.1X)

## 2.11 ISO management

### Access to the MDI mode or the ISO mode

The ISO key may be used to access the MDI mode or the ISO mode.

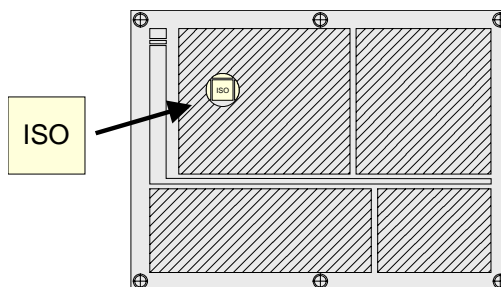

To access the MDI mode, the CNC must be in jog mode and the ISO key must be pressed. The CNC will show a window at the bottom of the standard (or special) screen.

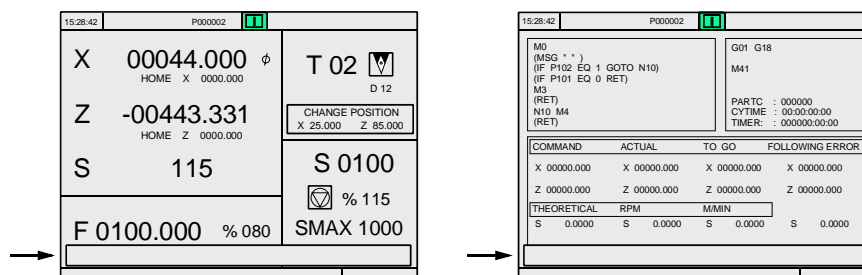

In this window, it is possible to edit a block in ISO code and then execute it, like in MDI in T mode.

### Displaying the last 10 MDI instructions

From the MDI mode, pressing the [UP ARROW] or [DOWN ARROW] key opens a window that shows the last 10 instructions that have been executed. This window resizes itself to fit the number of instructions that have been saved.

To execute or modify an MDI line that has been executed earlier, proceed as follows:

- Go into MDI mode.
- Press the [UP ARROW] or [DOWN ARROW] key to open the window that shows the last MDI instructions (up to 10).
- Use the [UP ARROW] or [DOWN ARROW] key to select the desired instruction.
  - Press [START] to execute the selected instruction.
  - Press [ENTER] to modify the selected instruction. Once the instruction has been modified, press [START] to execute it.

#### Some points to consider:

- An MDI instruction is saved only if it is correct and if it is not the same as the previous one on the list.
- The instructions are kept saved even after turning the unit off.

### Generating an ISO-coded program

In the conversational mode of the CNC, it is possible to generate an ISO-coded program from an operation (cycle) or on a part-program. See ["7.5 Graphic representation"](#) on page 180.

2.

OPERATING IN JOG MODE  
ISO management



CNC 8055  
CNC 8055i

.TC- OPTION  
(SOFT: V16.1x)

# 2.

## OPERATING IN JOG MODE ISO management



CNC 8055  
CNC 8055i

.TC. OPTION  
(SOFT: V16.1x)



# WORKING WITH OPERATIONS OR CYCLES

# 3

Use the following CNC keys to select the different machining operations or cycles.

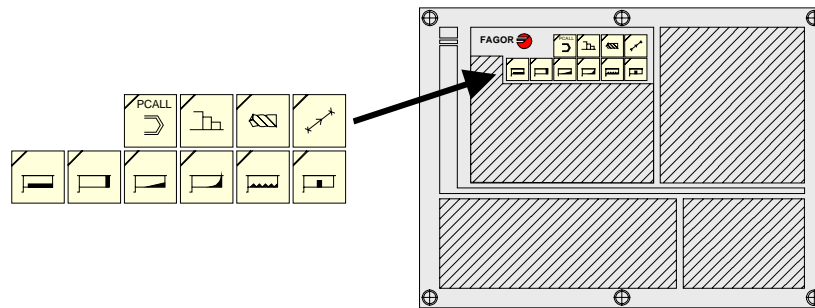

## User cycles



When pressing [PCALL], the CNC shows all the user cycles defined by the machine manufacturer with the WGDRAW application.

The user cycle is edited like any other standard cycle of the TC mode. Once all the required data has been defined, the user can simulate or execute the cycle like any other standard cycle of the TC mode.

## Cycles or operations of the CNC

When pressing any other key, the CNC selects the corresponding standard machining cycle, changes the display and turns on the lamp of the key that has been pressed (indicating the selected type).

Standard machining operations or cycles may be selected with each one of the following keys:

- |  |                      |  |                             |
|--|----------------------|--|-----------------------------|
|  | Positioning cycle.   |  | Threading cycle.            |
|  | Turning cycle.       |  | Grooving cycle.             |
|  | Facing cycle.        |  | Drilling and tapping cycle. |
|  | Taper turning cycle. |  | Profiling cycle.            |
|  | Rounding cycle.      |  |                             |



When the machining operation or cycle has several levels, [LEVEL CYCLE] must be pressed to select the desired cycle level.

It is possible to combine ISO-coded blocks with standard and/or user cycles to create part-programs. Chapter **"6 Saving programs"** describes in detail how to do it and how to use those programs.



CNC 8055  
CNC 8055i

.TC- OPTION  
(SOFT: V16.1X)

To de-select a cycle and return to the standard screen, press the key for the selected cycle (the one with the lamp on) or the [ESC] key.



*When operating in conversational mode, do not use global parameters 150 through 299 (both included), because the operations or cycles can modify these parameters and cause the machine to malfunction.*

# 3.

## WORKING WITH OPERATIONS OR CYCLES



CNC 8055  
CNC 8055i

.TC. OPTION  
(SOFT: V16.1X)

### 3.1 Operation editing mode

Once the operation has been selected, the CNC shows a screen like the following:

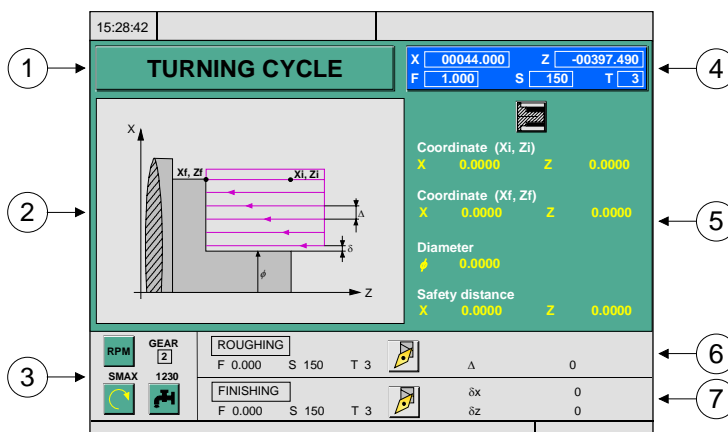

1. Name of the selected operation or work cycle.
2. Help graphics.
3. Spindle conditions to execute the cycle.
4. Current machine status. Coordinates and machining conditions.
5. Data defining the machining geometry.
6. Machining conditions for the roughing operation.
7. Machining conditions for the finishing operation.

The CNC will highlight an icon, a coordinate or one of the data defining the operation or cycle indicating that it has been selected. Use the following keys to select another icon, data or coordinate.

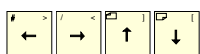

The CNC selects the previous one or the next one.

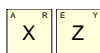

The CNC selects the first coordinate for that axis. Pressing that key again selects the next coordinate for that axis.

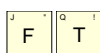

The CNC selects the corresponding roughing data. Pressing that key again selects the corresponding finishing data.



The CNC selects the "S" roughing data. Pressing that key again selects the finishing "S" data and pressing it again selects the data for the spindle SMAX.

The coordinates for the X axis are defined in the work units, radius or diameter. Later on, each operation or cycle indicates the units used to define the data associated with the X axis (safety distance, pass, excess stock, etc.).

# 3.

WORKING WITH OPERATIONS OR CYCLES  
Operation editing mode



CNC 8055  
CNC 8055i

.TC- OPTION  
(SOFT: V16.1x)

### 3.1.1 Definition of spindle conditions

**3.**  
WORKING WITH OPERATIONS OR CYCLES  
Operation editing mode

#### Work mode (RPM) or (CSS)

---

Place the cursor on the "RPM" or "CSS" icon. To do this, use the [CSS] key or the [↑] [↓] [←] [→] keys.

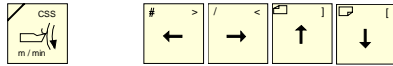

Once the data has been selected, press the [CSS] key or the two-color key to change the work mode.

#### Spindle range

---

Place the cursor on this data, key in the desired value and press [ENTER].

##### *In cycles using a live tool:*



Icon for selecting the spindle gear to be used for machining cycles where a live tool is used. The possible values are:

- 0 value: Gear corresponding to the S value
- Value of 1: Gear 1
- Value of 2: Gear 2
- Value of 3: Gear 3
- Value of 4: Gear 4

#### Maximum spindle speed (S) in rpm

---

Place the cursor on this data, key in the desired value and press [ENTER].

#### Spindle turning direction

---

There are two ways to select the spindle turning direction.



Place the cursor on this data and press the two-color key to change the icon.

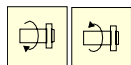

Start the spindle in the desired direction with the JOG keys. The CNC starts the spindle and assumes that turning direction as spindle turning data for the cycle.

#### Coolant

---

There are two ways to turn the coolant on or off.



Place the cursor on this data and press the two-color key to change the icon.



Turns the coolant on. The CNC sends the M8 function to the PLC.



Turns the coolant off. The CNC sends the M9 function to the PLC.

Once the operation or cycle has ended, or the part-program it belongs to, the CNC sends the M9 function to the PLC.

### 3.1.2 Definition of machining conditions

Some operations keep the machining conditions throughout the execution (positioning cycles, drilling cycle, etc.). Other operations use some machining conditions for roughing and others for finishing (turning cycle, rounding cycle, etc.).

This section describes how to define all this data.

#### **Selecting the roughing operation.**

Place the cursor on the roughing checkbox, select or de-select the roughing operation pressing the [TWO-COLOR] key and press [ENTER]. When de-selecting the roughing, all its data will stay in gray.

The data "side finishing stock" of the finishing portion is turned on/off using the roughing checkbox

#### **Selecting the finishing operation.**

Place the cursor on the finishing checkbox, select or de-select the finishing operation pressing the [TWO-COLOR] key and press [ENTER]. When de-selecting the finishing, all its data will stay in gray.

#### **Axis feedrate (F).**



Place the cursor on this data, key in the desired value and press [ENTER].

#### **Spindle speed (S).**



Place the cursor on this data, key in the desired value and press [ENTER].

#### **Machining tool (T).**

Place the cursor on this data, key in the desired value and press [ENTER].

The CNC updates the associated offset (D) and refreshes the associated icon showing the graphics for the location code (shape) of the new tool.



It is also possible to access the tool calibration mode to check or modify the data for the selected tool. To do that, place the cursor on the "T" and press the key associated with tool calibration.

Press [ESC] to quit the tool calibration mode and return to the cycle

#### **Tool offset number (D).**

Place the cursor on this data, key in the desired value and press [ENTER].



#### **Pocket machining direction.**

Icon to set the machining direction of the roughing tool.

3.

WORKING WITH OPERATIONS OR CYCLES  
Operation editing mode

### Machining direction.

It is possible to select the machining direction (turning direction or facing direction) in certain cycles.

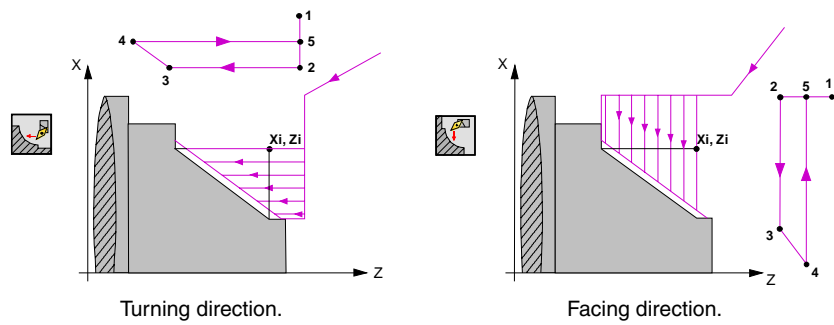

Place the cursor on this icon and press the two-color key. The icon changes and the help graphics are refreshed.

### Roughing pass ( $\Delta$ ).

Place the cursor on this data, key in the desired value and press [ENTER]. The roughing pass is always defined in radius.



### Finishing stock ( $\delta$ ).

The roughing pass is always defined in radius. Place the cursor on this data, key in the desired value and press [ENTER].



### Sideways penetration angle ( $\beta, \theta$ ).

Sideways penetration angle. If programmed with a value smaller than or equal to  $0^\circ$ , or greater than  $90^\circ$ , it issues the corresponding error message. If not programmed, it assumes  $90^\circ$ .

### Auxiliary (miscellaneous) "M" functions.

There is a window for setting up to 4 auxiliary M functions in the roughing and finishing operations. The functions will be executed in the same order they are inserted on the list.

Select the corresponding window with the [←][→] keys Use the [↑][↓] keys to move around the window.

To delete a function, select it and press [CLEAR]



The availability of "M" functions in the cycles is determined with g.m.p. "CODISET (P147)".

**3.**  
WORKING WITH OPERATIONS OR CYCLES  
Operation editing mode



CNC 8055  
CNC 8055i

-TC- OPTION  
(SOFT: V16.1X)

### 3.1.3 Cycle level

All the cycles have several editing levels. Each level has its own screen and the main window of the cycle indicates, with tabs, the available levels and which one is selected.

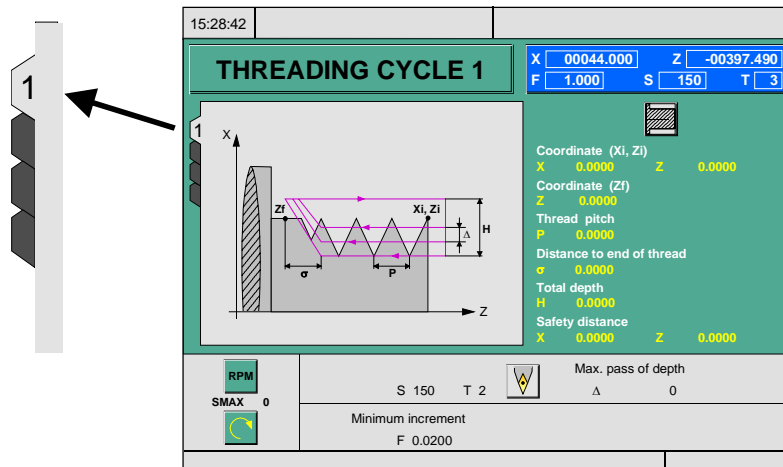

LEVEL CYCLE

To change levels, use the [LEVEL CYCLE] key or the [page up] and [page down] keys to scroll up and down through the various levels.

3.

WORKING WITH OPERATIONS OR CYCLES  
Operation editing mode

### 3.2 Simulating and executing the operation

All the operations or cycles have 2 work modes; execution and editing.

- Press [ESC] to switch from editing mode to execution mode.
- Press [ESC] to switch from executing mode to editing mode.

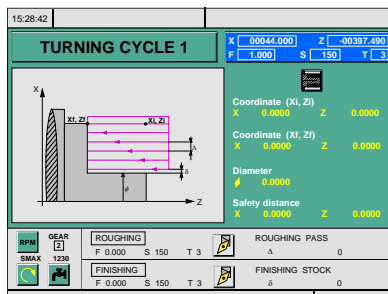
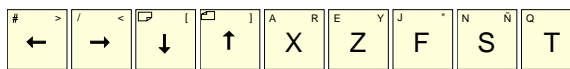

Editing mode

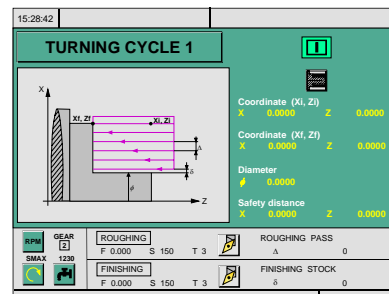

Execution mode



The operation or cycle may be simulated in either mode. To do that, press the [GRAPHICS] key.



To execute the operation or cycle, select the execution mode and press [START].

For further information on simulating and executing cycles, see the chapter **"7 Execution and simulation"**.

**3.** WORKING WITH OPERATIONS OR CYCLES  
Simulating and executing the operation



CNC 8055  
CNC 8055i

.TC- OPTION  
(SOFT: V16.1X)



### 3.2.1 Background cycle editing

It is possible to edit an operation or cycle while executing a program or part (background editing). The new operation edited may be saved as part of a part-program other than the one being executed.

The operation being edited in background cannot be executed or simulated, and the current position of the machine cannot be assigned to a coordinate.

Use the following keys to inspect or change a tool while editing in background.



Interrupts the execution and goes on editing in background.



To quit background editing.



To access tool inspection.

Pressing the [T] key without quitting background editing selects the T field of the operation or of the canned cycle being edited.



*Background editing is not possible while executing an independent operation or cycle. It can only be done while executing a program or part.*

3.

**WORKING WITH OPERATIONS OR CYCLES**  
 Simulating and executing the operation



CNC 8055  
 CNC 8055i

.TC- OPTION  
 (SOFT: V16.1X)

### 3.3 Positioning cycle



This key accesses the positioning operation.

This cycle may be defined in two ways:

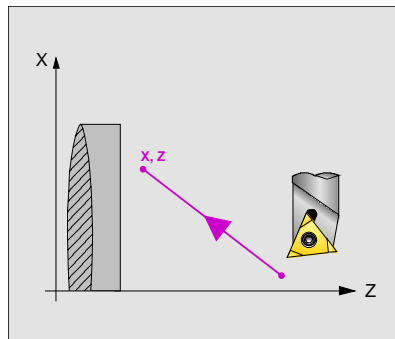

#### Level 1.

The following data must be defined:

- Coordinates of the target point.
- How the movement is to be carried out.
- The type of feed; in rapid or at the programming feedrate.

#### Level 2.

The following data must be defined:

- Coordinates of the target point.
- How the movement is to be carried out.
- The type of feed; in rapid or at the programming feedrate.
- The auxiliary functions that will be executed before and after the movement.

# 3.

WORKING WITH OPERATIONS OR CYCLES  
Positioning cycle



CNC 8055  
CNC 8055i

-TC- OPTION  
(SOFT: V16.1X)

### 3.3.1 Definition of data

#### Order in which the axes move.



To select the moving order, place the cursor over this icon and press the two-color key.



All two axes at the same time.



First X and then Z.



First Z and then X.

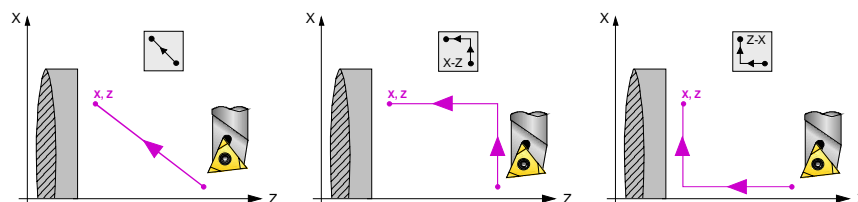

#### Type of feedrate.



To select the type of feedrate, place the cursor over this icon and press the two-color key.



Programmed feedrate.



Rapid traverse.

#### Coordinates of the target point (X, Z).

The coordinates are defined one by one. After placing the cursor on the coordinates of the axes to be defined, the value is entered in one of the following ways.

- Entering the value manually. Key in the desired value and press [ENTER].
- Assign the current machine position.

Jog the axis with the handwheel or the JOG keys up to the desired point. Press [RECALL] so the selected data assumes the value shown in the top right window and press [ENTER].

The top right window shows the tool position at all times.

#### Auxiliary (miscellaneous) "M" functions.

Auxiliary "M" functions are those set by the manufacturer for governing various devices of the machine. Some auxiliary "M" functions are used to interrupt the program, to select the spindle turning direction, to control the coolant, the spindle gear box, etc.

The programming manual describes how to program these functions and the installation manual describes how to set up the system to use them.

To define the auxiliary functions, select the corresponding window with the [←][→] keys. Use the [↑][↓] keys to move around the window. To delete a function, select it and press [CLEAR]

The functions will be executed in the same order they are inserted on the list.

3.

WORKING WITH OPERATIONS OR CYCLES  
Positioning cycle

FAGOR 

CNC 8055  
CNC 8055i

.TC- OPTION  
(SOFT: V16.1X)

## 3.4 Turning cycle



This key accesses the turning cycle.

This cycle may be defined in several ways:

# 3.

WORKING WITH OPERATIONS OR CYCLES  
Turning cycle

### Turning levels 1 and 2

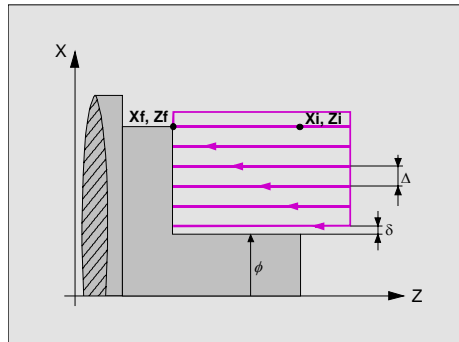

#### Level 1.

The following data must be defined:

- Coordinates of the starting point.
- Coordinates of the last point.
- The final diameter.
- The safety distance.

#### Level 2.

The following data must be defined:

- Coordinates of the starting point.
- Coordinates of the last point.
- The final diameter.
- The type of machining at each corner.
- The safety distance.



CNC 8055  
CNC 8055i

-TC- OPTION  
(SOFT: V16.1X)

## Turning levels 3, 4 and 5

### Level 3. Rectangular pocket on the cylindrical side of the part.

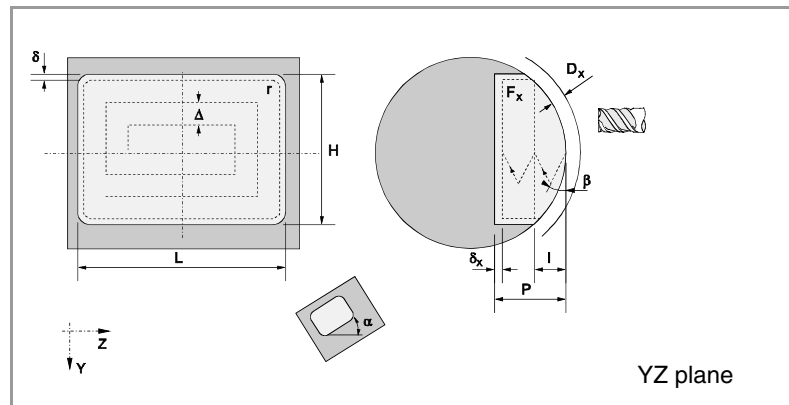
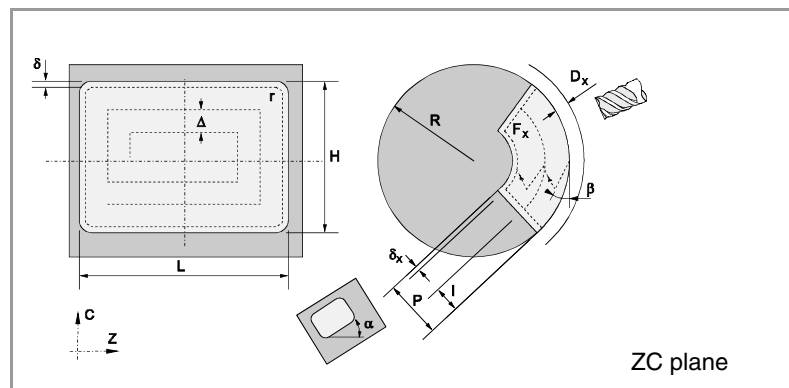

### Level 4. Circular pocket on the cylindrical side of the part.

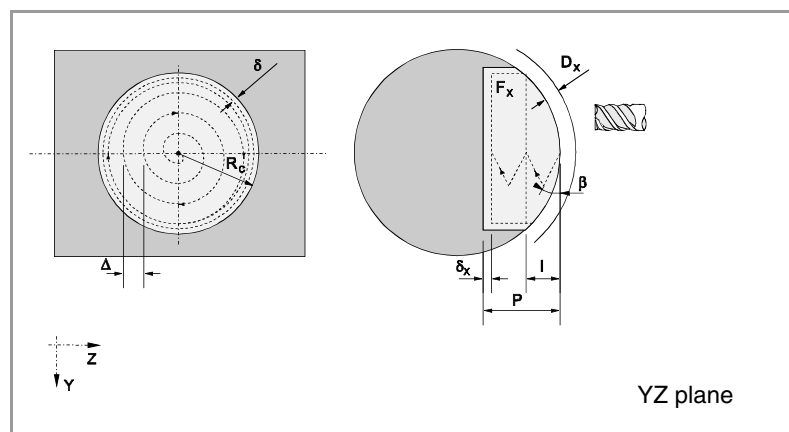
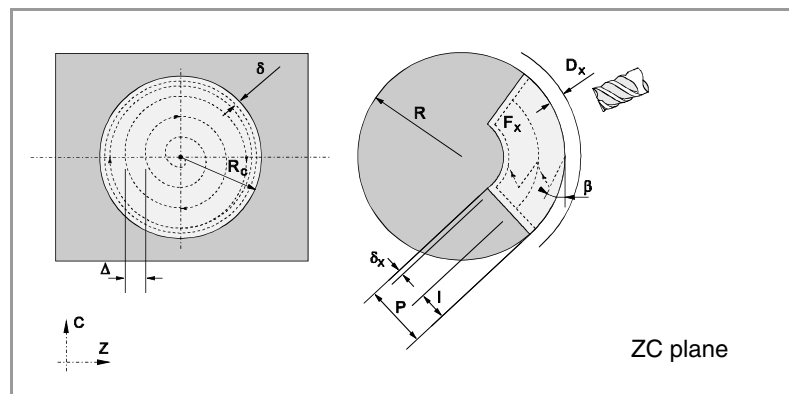

3.

WORKING WITH OPERATIONS OR CYCLES  
Turning cycle

FAGOR

CNC 8055  
CNC 8055i

-TC- OPTION  
(SOFT: V16.1X)

Level 5. ZC / YC profile cycle.

**3.**

WORKING WITH OPERATIONS OR CYCLES  
Turning cycle

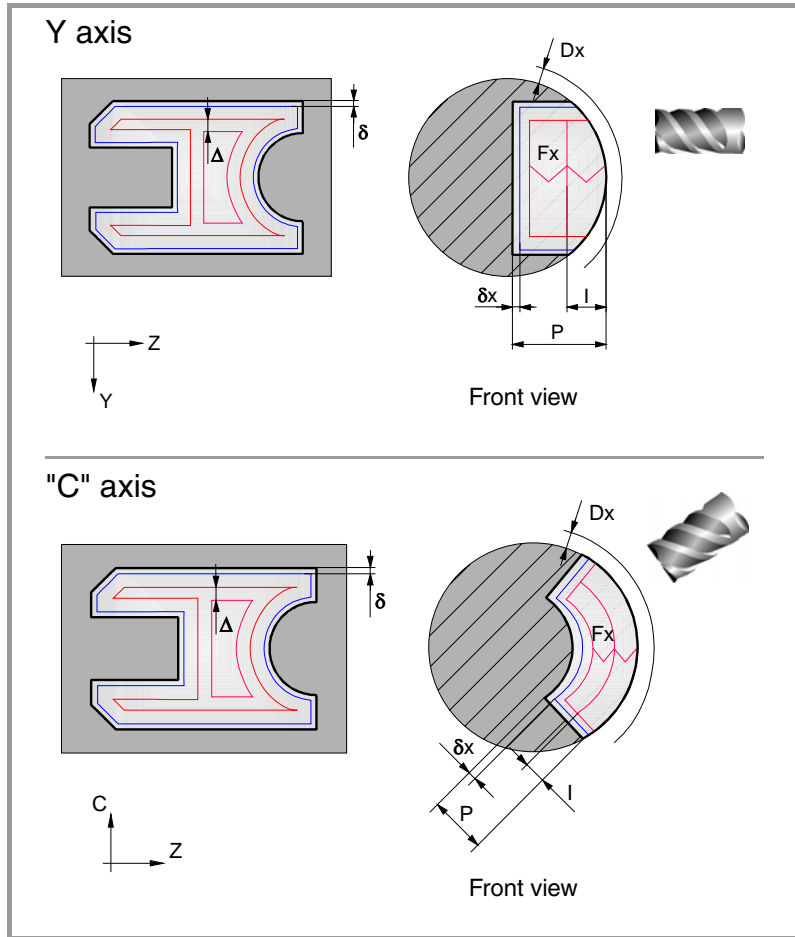

CNC 8055  
CNC 8055i

.TC. OPTION  
(SOFT: V16.1X)

### 3.4.1 Data definition (levels 1 and 2)

#### Type of turning operation.



To select the type of turning operation, place the cursor over this icon and press the two-color key.



Inside turning.



Outside turning.

When changing the type of turning operation, the CNC changes the icon and shows the corresponding help screen.

#### Coordinates of the first point ( $X_i, Z_i$ ) and of the last point ( $X_f, Z_f$ ).

The coordinates are defined one by one. After placing the cursor on the coordinates of the axes to be defined, the value is entered in one of the following ways.

- Entering the value manually. Key in the desired value and press [ENTER].
- Assign the current machine position.

Jog the axis with the handwheel or the JOG keys up to the desired point. Press [RECALL] so the selected data assumes the value shown in the top right window and press [ENTER].

The top right window shows the tool position at all times.

#### Final diameter ( $\phi$ ).

Place the cursor on this data, key in the desired value and press [ENTER].

#### Safety distance.

A part approach point may be set to prevent the tool from colliding with the part. The safety distance indicates the position of the approach point referred to the starting point ( $X_i, Z_i$ ).

To change one of these values, place the cursor on the corresponding data, key in the desired value and press [ENTER].

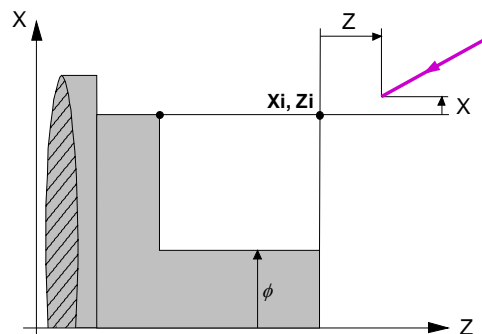

The safety distance in X is always defined in radius.

# 3.

WORKING WITH OPERATIONS OR CYCLES  
Turning cycle



CNC 8055  
CNC 8055i

.TC- OPTION  
(SOFT: V16.1X)

**Type of machining for each corner.**



To select the type of corner, place the cursor over this icon and press the two-color key.

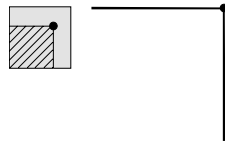

Square corner.

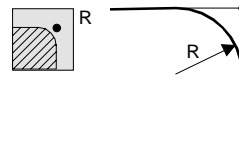

Rounded corner.

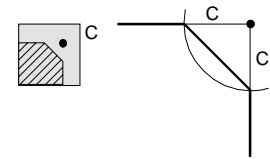

Chamfered corner.

For a rounded corner, define the rounding radius (R); for a chamfer, define the distance from the theoretical corner to the chamfer point (C).

**Finishing stocks in X-Z.**

2 different residual stocks may be defined, one for each axis (X, Z). To define these residual stocks, place the cursor on the corresponding data, key in the desired value and press [ENTER].

**3.**

WORKING WITH OPERATIONS OR CYCLES  
Turning cycle



CNC 8055  
CNC 8055i

.TC· OPTION  
(SOFT: V16.1X)



### 3.4.2 Data definition (levels 3, 4 and 5)

#### Level 3:



Icon for selecting the ZC or YZ plane.



Icon to select the position of the starting point.

**Z,C /  
Z,Y:**

Coordinates of the starting point.

**L, H:** Pocket dimensions.

**$\alpha$ :** Inclination angle of the rectangular pocket.

**W:** Angular position of the spindle (in degrees) where the pocket will be milled in the YZ plane.



Icon for selecting the vertex type in the pocket corners:

- Normal vertex
- Rounded vertex
- Chamfered vertex

**r / c:** Value of the corner rounding or chamfering radius in the rectangular pocket.

**Dx:** Safety distance on the longitudinal axis (cylindrical side).

**Dz:** Safety distance on the longitudinal axis (face).

**X:** Part plane.

**P:** Total rectangular pocket depth. When programmed with a 0 value, it generates the corresponding error.

**I:** Penetration step (pass) when roughing:

- If programmed with a positive value, the actual step (pass) will be the one closest to this value so all passes will be identical.
- If programmed with a negative value, the actual pass will be the one programmed and the last pass will be adjusted to the final (remaining) depth.
- If not programmed, it assumes 0.

**Fx:** Penetration feedrate for roughing and finishing. If not programmed, it assumes 0.

#### Level 4:



Icon to select the ZC or YZ plane.

**Zc, Cc /  
Zc, Yc:** Center coordinates of the circular pocket.

**Rc:** Circular pocket radius.

**W:** Angular position of the spindle (in degrees) where the pocket will be milled in the YZ plane.

**Dx:** Safety distance on the longitudinal axis (cylindrical side).

**Dz:** Safety distance on the longitudinal axis (face).

**R / X:**

- Cylinder radius when it is the ZC plane.
- X coordinate of the part surface when it is the ZY plane.

**P:** Total circular pocket depth. When programmed with a 0 value, it generates the corresponding error.

3.

WORKING WITH OPERATIONS OR CYCLES  
Turning cycle

**FAGOR** 

**CNC 8055  
CNC 8055i**

-TC- OPTION  
(SOFT: V16.1X)

# 3.

WORKING WITH OPERATIONS OR CYCLES  
Turning cycle

- I:** Penetration step (pass) when roughing:
- If programmed with a positive value, the actual step (pass) will be the one closest to this value and all the passes will be identical.
  - If programmed with a negative value, the actual pass will be the one programmed and the last pass will be adjusted to the final (remaining) depth.
  - If not programmed, it assumes 0.
- Fx:** Penetration feedrate for roughing and finishing. If not programmed, it assumes F/2.

**Level 5:**

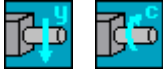

Icon for selecting the machining plane (ZC plane or YZ plane).

**Profile program:** Number of the part-program where the pocket is defined.

- Dx:** Safety distance on the longitudinal axis.
- X:** X coordinate of the part surface when it is the YZ plane.
- R:** Part radius when it is the ZC plane.
- P:** Total profile pocket depth. If not programmed or programmed with a 0 value, the CNC will display the corresponding error message.
- I:** Maximum roughing pass. If not programmed or if programmed with a 0 value, it assumes the value of 75% of the diameter of the roughing tool.
- Fx:** Machining feedrate along the X axis. If not programmed or programmed with a 0 value, the CNC assumes the roughing F value for the penetration in roughing and the finishing F for the penetration in finishing.
- W:** Angular position of the spindle (in degrees) where the profile will be machined in the YZ plane (in degrees).



Spindle turning direction



CNC 8055  
CNC 8055i

.TC- OPTION  
(SOFT: V16.1X)

### 3.4.3 Basic operation (levels 1 and 2)

The machining steps for this cycle are:

1. If the roughing operation has been programmed with another tool, the CNC will change the tool and will move to the change position if so required by the machine.
2. The spindle starts at the selected speed and in the indicated direction.
3. The tool approaches in rapid to the starting point ( $X_i, Z_i$ ) keeping the selected safety distance in X and Z.

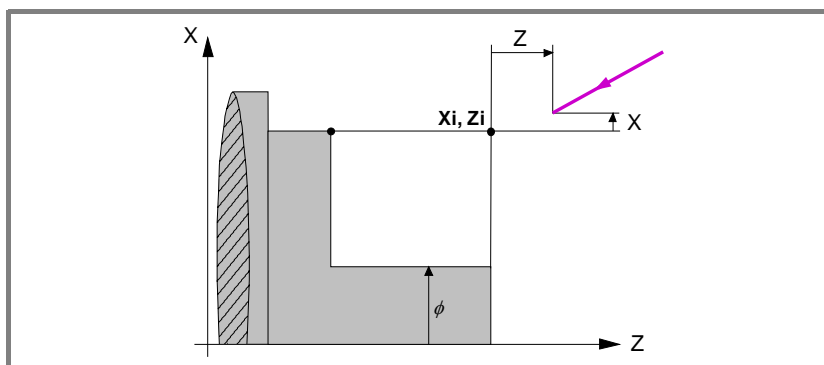

4. Roughing operation, with successive turning passes, up to a distance from the selected final diameter equal to the finishing stock.

This operation is carried out with the conditions set for the roughing operations; however, the CNC calculates the actual (real) pass so all the turning passes are identical. This pass will be equal to or smaller than the one defined  $\Delta$ .

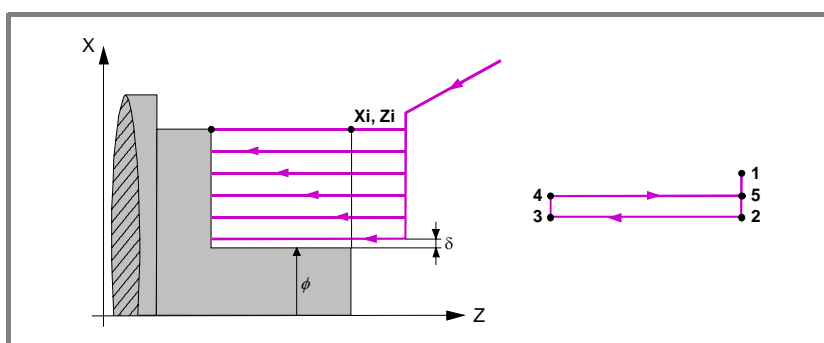

Each turning pass is done as shown in the figure, starting at point "1" and after going through points "2", "3" and "4", ending at point "5".

5. Finishing operation.  
If the finishing operation has been programmed with another tool, the CNC will change the tool and will move to the change position if so required by the machine.  
The finishing of the part is carried out with the machining conditions set for finishing; feedrate of the axes (F), spindle speed (S) and turning direction.
6. Once the operation or cycle has ended, the tool will return to the position it occupied when calling the cycle; i.e. to the point where [START] was pressed.  
When executing an entire part, combination of operations or cycles, the tool does not return to that point after executing each cycle.
7. The CNC stops the spindle, but it keeps the machining conditions set for finishing; tool (T), feedrate of the axes (F) and spindle speed (S).

3.

WORKING WITH OPERATIONS OR CYCLES  
Turning cycle



CNC 8055  
CNC 8055i

.TC- OPTION  
(SOFT: V16.1X)

## Considerations

### How to leave out the roughing or finishing operations.

By selecting T0 as the roughing tool, the cycle does not execute the roughing operation. In other words, after the approach movement, it will carry out the finishing operation.

By selecting T0 as the finishing tool, the cycle does not execute the finishing operation. In other words, after the roughing operation, the tool will move to the approach point maintaining the safety distance from the starting point (Xi, Zi).

### Different Xi and Xf coordinates.

When the surface to be machined is not totally cylindrical (different Xi and Xf coordinates), the CNC analyzes both coordinates and takes as the X coordinate of the starting point the one farthest away from the final diameter.

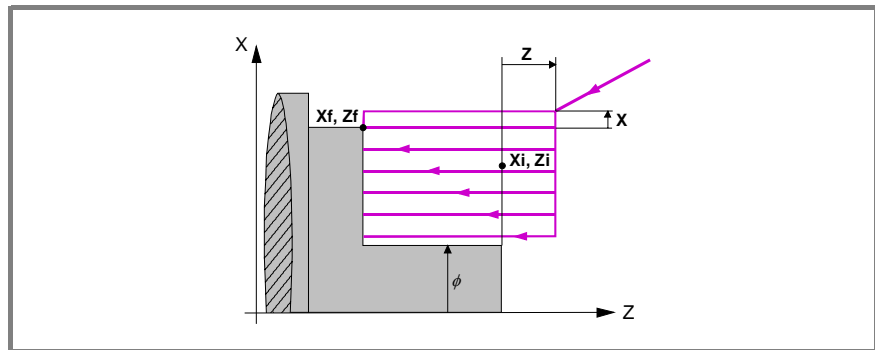

# 3.

WORKING WITH OPERATIONS OR CYCLES  
Turning cycle



CNC 8055  
CNC 8055i

-TC- OPTION  
(SOFT: V16.1X)

## 3.5 Facing cycle



This key accesses the facing cycle.

This cycle may be defined in several ways:

### Facing levels 1 and 2

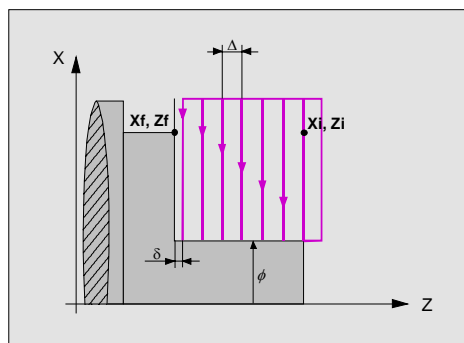

#### Level 1.

The following data must be defined:

- Coordinates of the starting point.
- Coordinates of the last point.
- The final diameter.
- The safety distance.

#### Level 2.

The following data must be defined:

- Coordinates of the starting point.
- Coordinates of the last point.
- The final diameter.
- The type of machining at each corner.
- The safety distance.

3.

WORKING WITH OPERATIONS OR CYCLES  
Facing cycle

FAGOR 

CNC 8055  
CNC 8055i

.TC- OPTION  
(SOFT: V16.1X)

### Facing levels 3, 4 and 5

#### Level 3. Rectangular pocket on the face of the part.

**3.**

WORKING WITH OPERATIONS OR CYCLES  
Facing cycle

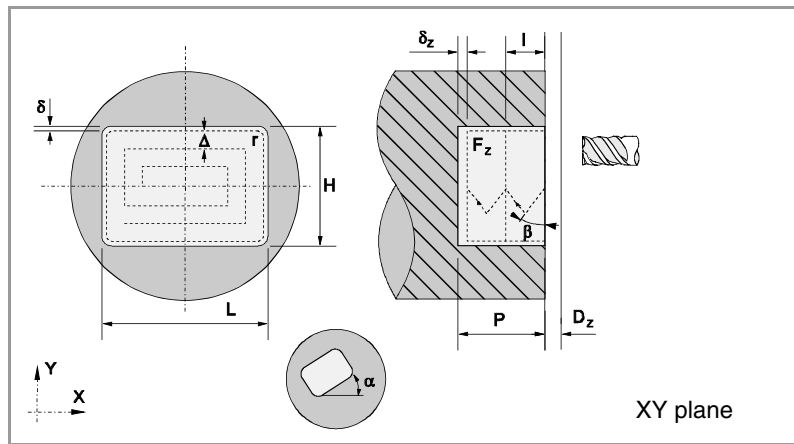
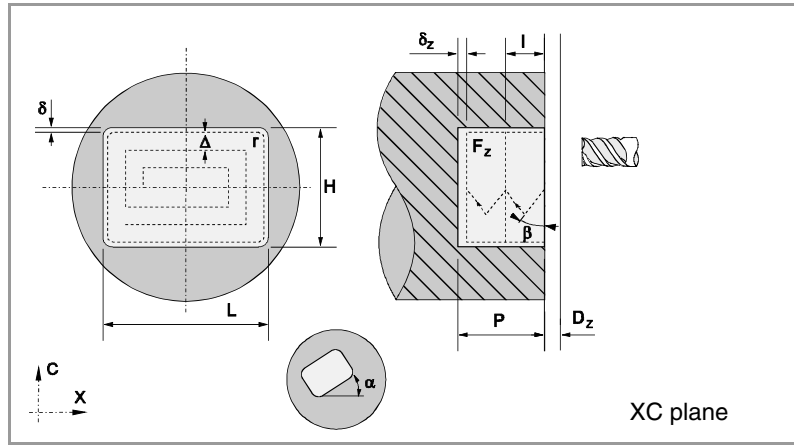

#### Level 4. Circular pocket on the face of the part.

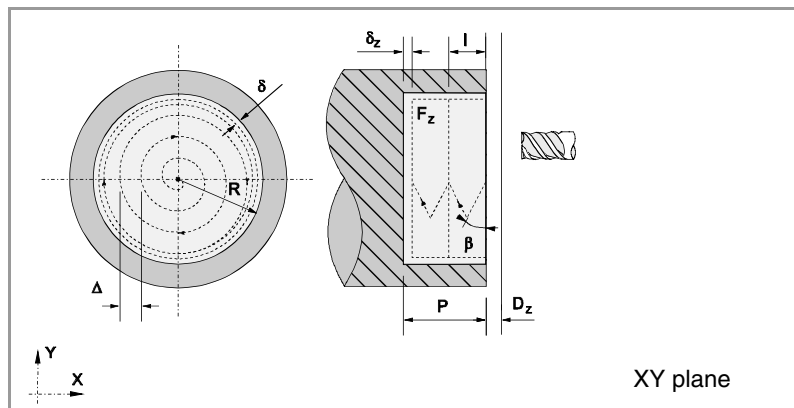
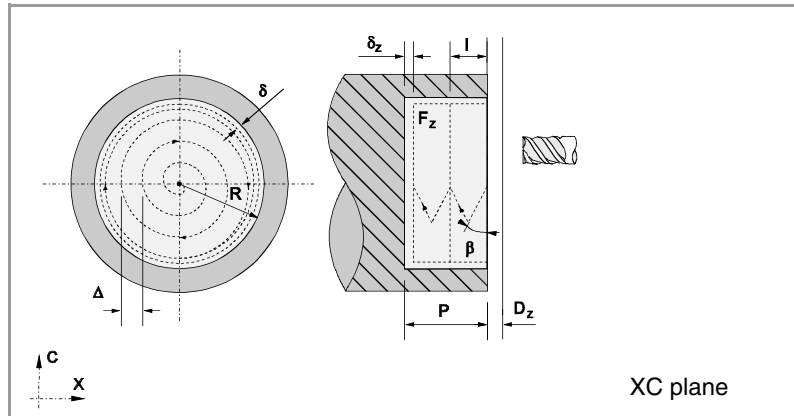

CNC 8055  
CNC 8055i

-TC- OPTION  
(SOFT: V16.1X)

Level 5. XC / XY profile cycle.

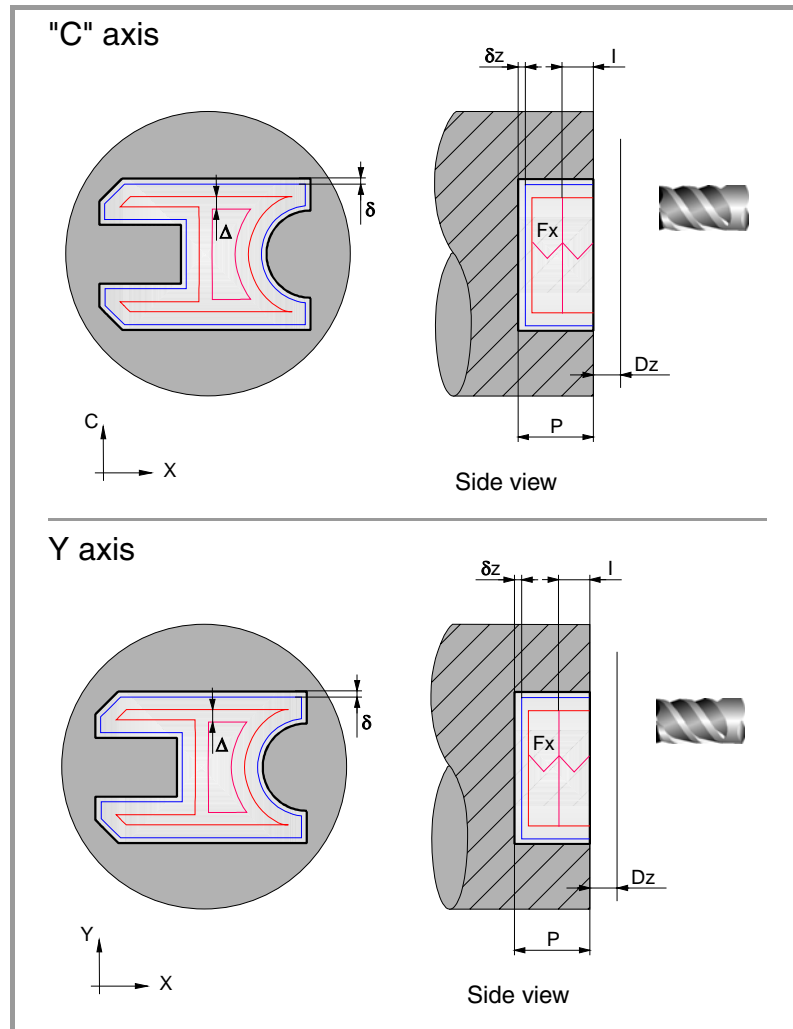

**3.**

WORKING WITH OPERATIONS OR CYCLES  
Facing cycle



CNC 8055  
CNC 8055i

.TC- OPTION  
(SOFT: V16.1X)

### 3.5.1 Data definition (levels 1 and 2)

#### Coordinates of the first point ( $X_i, Z_i$ ) and of the last point ( $X_f, Z_f$ ).

The coordinates are defined one by one. After placing the cursor on the coordinates of the axes to be defined, the value is entered in one of the following ways.

- Entering the value manually. Key in the desired value and press [ENTER].
- Assign the current machine position.

Jog the axis with the handwheel or the JOG keys up to the desired point. Press [RECALL] so the selected data assumes the value shown in the top right window and press [ENTER].

The top right window shows the tool position at all times.

#### Final diameter ( $\phi$ ).

Place the cursor on this data, key in the desired value and press [ENTER].

#### Type of machining for each corner.

To select the type of corner, place the cursor over this icon and press the two-color key.

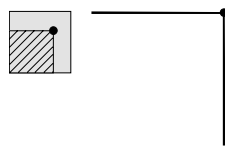

Square corner.

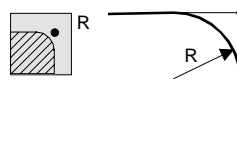

Rounded corner.

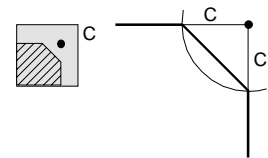

Chamfered corner.

For a rounded corner, define the rounding radius (R); for a chamfer, define the distance from the theoretical corner to the chamfer point (C).

#### Safety distance.

A part approach point may be set to prevent the tool from colliding with the part. The safety distance indicates the position of the approach point referred to the starting point ( $X_i, Z_i$ ).

To change one of these values, place the cursor on the corresponding data, key in the desired value and press [ENTER].

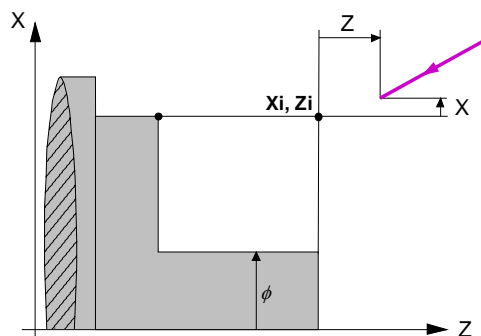

The safety distance in X is always defined in radius.

#### Finishing stocks in X-Z.

2 different residual stocks may be defined, one for each axis (X, Z). To define these residual stocks, place the cursor on the corresponding data, key in the desired value and press [ENTER].

3. WORKING WITH OPERATIONS OR CYCLES Facing cycle



CNC 8055  
CNC 8055i

-TC- OPTION  
(SOFT: V16.1X)



### 3.5.2 Data definition (levels 3, 4 and 5)

#### Level 3:



Icon for selecting the ZC or YZ plane.



Icon to select the position of the starting point.

**Z,C /  
Z,Y:**

Coordinates of the starting point.

**L, H:**

Pocket dimensions.

**α:**

Inclination angle of the rectangular pocket.

**W:**

Angular position of the spindle (in degrees) where the pocket will be milled in the YZ plane.



Icon for selecting the vertex type in the pocket corners:

- Normal vertex
- Rounded vertex
- Chamfered vertex

**r / c:**

Value of the corner rounding or chamfering radius in the rectangular pocket.

**Dx:**

Safety distance on the longitudinal axis (cylindrical side).

**Dz:**

Safety distance on the longitudinal axis (face).

**X:**

Part plane.

**P:**

Total rectangular pocket depth. When programmed with a 0 value, it generates the corresponding error.

**I:**

Penetration step (pass) when roughing:

- If programmed with a positive value, the actual step (pass) will be the one closest to this value so all passes will be identical.
- If programmed with a negative value, the actual pass will be the one programmed and the last pass will be adjusted to the final (remaining) depth.
- If not programmed, it assumes 0.

**Fx:**

Penetration feedrate for roughing and finishing. If not programmed, it assumes 0.

#### Level 4:



Icon to select the ZC or YZ plane.

**Zc, Cc /  
Zc, Yc:**

Center coordinates of the circular pocket.

**Rc:**

Circular pocket radius.

**W:**

Angular position of the spindle (in degrees) where the pocket will be milled in the YZ plane.

**Dx:**

Safety distance on the longitudinal axis (cylindrical side).

**Dz:**

Safety distance on the longitudinal axis (face).

**R / X:**

- Cylinder radius when it is the ZC plane.
- X coordinate of the part surface when it is the ZY plane.

**P:**

Total circular pocket depth. When programmed with a 0 value, it generates the corresponding error.

3.

WORKING WITH OPERATIONS OR CYCLES  
Facing cycle

**FAGOR** 

**CNC 8055  
CNC 8055i**

-TC- OPTION  
(SOFT: V16.1X)

# 3.

WORKING WITH OPERATIONS OR CYCLES

Facing cycle

- I:** Penetration step (pass) when roughing:
  - If programmed with a positive value, the actual step (pass) will be the one closest to this value and all the passes will be identical.
  - If programmed with a negative value, the actual pass will be the one programmed and the last pass will be adjusted to the final (remaining) depth.
  - If not programmed, it assumes 0.
- Fx:** Penetration feedrate for roughing and finishing. If not programmed, it assumes F/2.

## Level 5:



Icon for selecting the machining plane (XC plane or XY plane).

## Profile program:

Number of the part-program where the pocket is defined.

- Dz:** Safety distance on the longitudinal axis.
- Z:** Z Defines the Z coordinate of the part surface.
- P:** Total profile pocket depth. If not programmed or programmed with a 0 value, the CNC will display the corresponding error message.
- I:** Maximum roughing pass. If not programmed or if programmed with a 0 value, it assumes the value of 75% of the diameter of the roughing tool.
- Fz:** Machining feedrate along the Z axis. If not programmed or programmed with a 0 value, the CNC assumes the roughing F value for the penetration in roughing and the finishing F for the penetration in finishing.
- W:** Angular position of the spindle (in degrees) where the profile will be machined in the XY plane (in degrees).



Spindle turning direction



CNC 8055  
CNC 8055i

.TC- OPTION  
(SOFT: V16.1X)

### 3.5.3 Basic operation (levels 1 and 2)

The machining steps for this cycle are:

1. If the roughing operation has been programmed with another tool, the CNC will change the tool and will move to the change position if so required by the machine.
2. The spindle starts at the selected speed and in the indicated direction.
3. The tool approaches in rapid to the starting point ( $X_i, Z_i$ ) keeping the selected safety distance in X and Z.

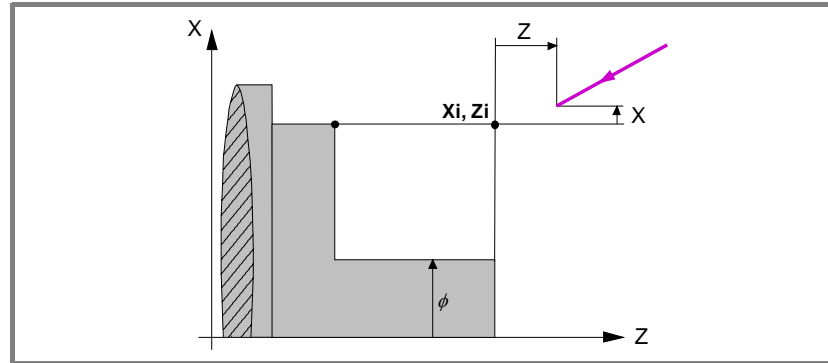

4. Roughing operation, with successive facing passes, up to a distance from the selected final Z coordinate ( $Z_f$ ) equal to the finishing stock.

This operation is carried out with the conditions set for the roughing operations; however, the CNC calculates the actual (real) pass so all the facing passes are identical. This pass will be equal to or smaller than the one defined  $\Delta$ .

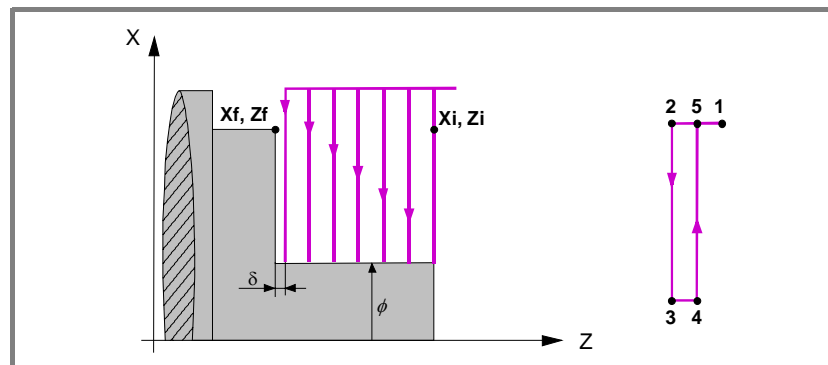

Each facing pass is done as shown in the figure, starting at point "1" and after going through points "2", "3" and "4", ending at point "5".

5. Finishing operation.  
If the finishing operation has been programmed with another tool, the CNC will change the tool and will move to the change position if so required by the machine.  
The finishing of the part is carried out with the machining conditions set for finishing; feedrate of the axes (F), spindle speed (S) and turning direction.
6. Once the operation or cycle has ended, the tool will return to the position it occupied when calling the cycle; i.e. to the point where [START] was pressed.  
When executing an entire part, combination of operations or cycles, the tool does not return to that point after executing each cycle.
7. The CNC stops the spindle, but it keeps the machining conditions set for finishing; tool (T), feedrate of the axes (F) and spindle speed (S).

3.

WORKING WITH OPERATIONS OR CYCLES  
Facing cycle



CNC 8055  
CNC 8055i

.TC- OPTION  
(SOFT: V16.1X)

## Considerations

### How to leave out the roughing or finishing operations.

By selecting T0 as the roughing tool, the cycle does not execute the roughing operation. In other words, after the approach movement, it will carry out the finishing operation.

By selecting T0 as the finishing tool, the cycle does not execute the finishing operation. In other words, after the roughing operation, the tool will move to the approach point maintaining the safety distance from the starting point ( $X_i, Z_i$ ).

### Different $X_i$ and $X_f$ coordinates.

When the surface to be machined is not totally cylindrical (different  $X_i$  and  $X_f$  coordinates), the CNC analyzes both coordinates and takes as the X coordinate of the starting point the one farthest away from the final diameter.

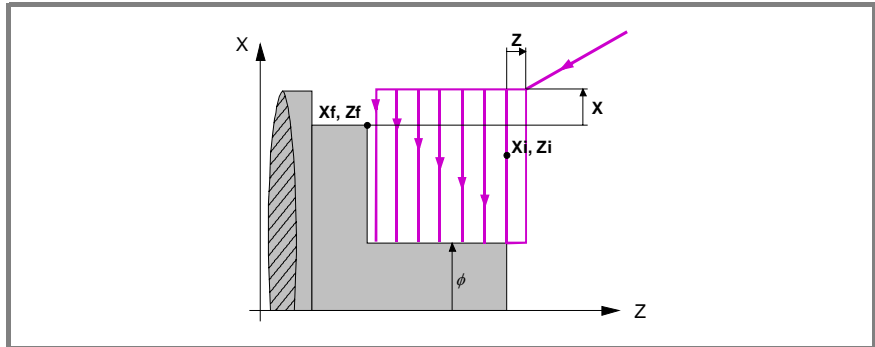

# 3.

WORKING WITH OPERATIONS OR CYCLES  
Facing cycle



CNC 8055  
CNC 8055i

-TC- OPTION  
(SOFT: V16.1x)

## 3.6 Taper turning cycle



This key accesses the taper turning cycles.

This cycle may be defined in two ways:

### Level 1.

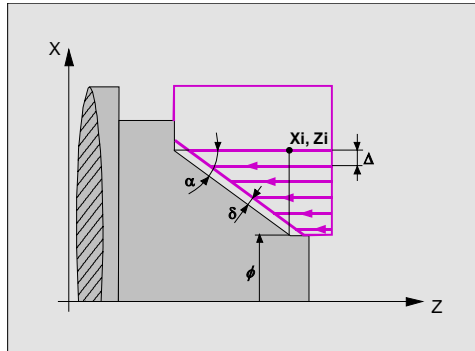

The following data must be defined:

- The coordinates of the theoretical corner.
- The inclination angle and the final diameter.

### Level 2.

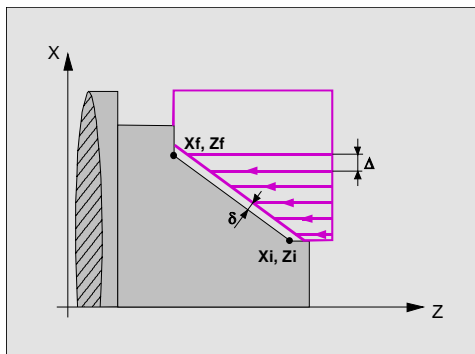

The following data must be defined:

- Coordinates of the starting point.
- Coordinates of the last point.

### Level 3.

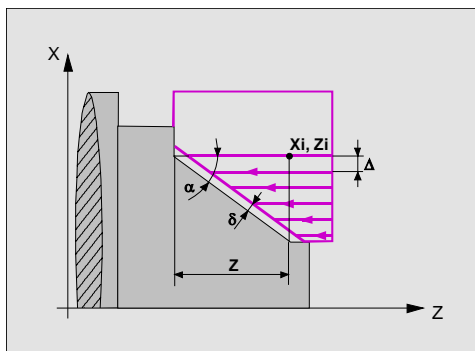

The following data must be defined:

- The coordinates of the theoretical corner.
- The taper angle and the distance in Z.

3.

WORKING WITH OPERATIONS OR CYCLES  
Taper turning cycle

FAGOR 

CNC 8055  
CNC 8055i

-TC- OPTION  
(SOFT: V16.1X)

### 3.6.1 Definition of data

#### Type of taper.



To select the type of taper turning operation, place the cursor over this icon and press the two-color key.



Inside taper.



Outside taper.

When changing the type of taper turning operation, the CNC changes the icon and shows the corresponding help screen.

#### Shape of the part before and after the taper section.



The type of section before and after the taper section is defined with the following icons. To select the desired type, place the cursor over this icon and press the two-color key.

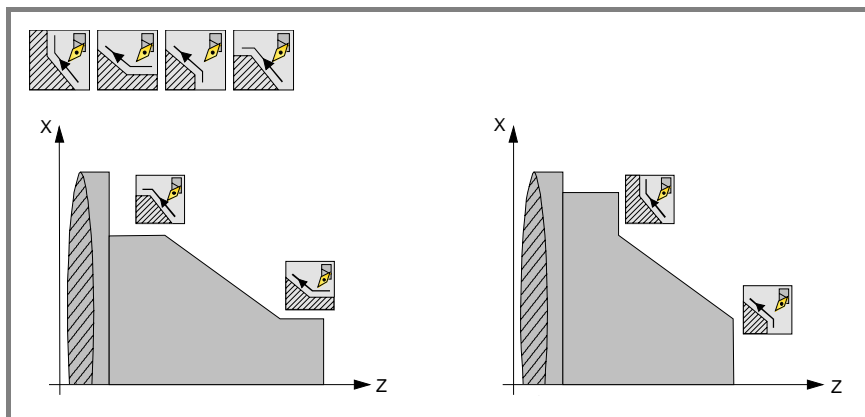

When changing the type of section, the CNC changes the icon and shows the corresponding help screen.

#### Work quadrant.



The work quadrant is defined with the following icons: To select the desired type, place the cursor over this icon and press the two-color key.

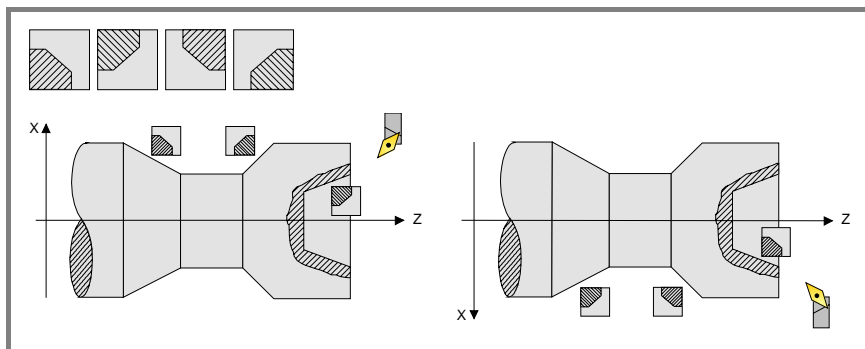

CNC 8055  
CNC 8055i

.TC- OPTION  
(SOFT: V16.1X)

**Coordinates of the theoretical corner, of the first point ( $X_i, Z_i$ ) and of the last point ( $X_f, Z_f$ ).**

The coordinates are defined one by one. After placing the cursor on the coordinates of the axes to be defined, the value is entered in one of the following ways.

- Entering the value manually. Key in the desired value and press [ENTER].
- Assign the current machine position.  
Jog the axis with the handwheel or the JOG keys up to the desired point. Press [RECALL] so the selected data assumes the value shown in the top right window and press [ENTER].

The top right window shows the tool position at all times.

**Final diameter ( $\Phi$ ).**

Place the cursor on this data, key in the desired value and press [ENTER].

**Angle ( $\alpha$ ).**

Place the cursor on this data, key in the desired value and press [ENTER].

**Chamfer (Z).**

Length of the taper, measured along the abscissa axis. Place the cursor on this data, key in the desired value and press [ENTER].

**Safety distance.**

A part approach point may be set to prevent the tool from colliding with the part. The safety distance indicates the position of the approach point referred to the theoretical corner.

To change one of these values, place the cursor on the corresponding data, key in the desired value and press [ENTER].

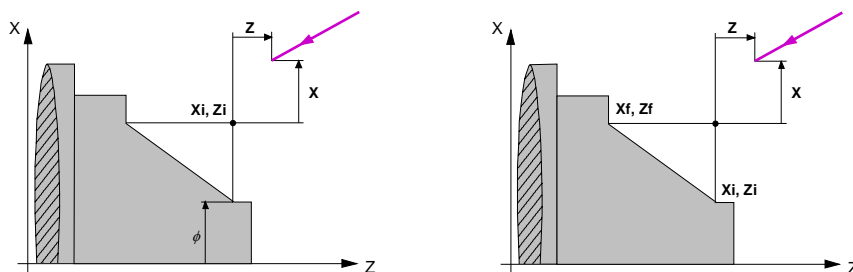

The safety distance in X is always defined in radius.

3.

WORKING WITH OPERATIONS OR CYCLES  
Taper turning cycle



CNC 8055  
CNC 8055i

.TC. OPTION  
(SOFT: V16.1X)

# 3.

WORKING WITH OPERATIONS OR CYCLES  
Taper turning cycle

## Machining direction.



The machining direction (turning direction or facing direction) is defined with the following icons. To select the desired type, place the cursor over this icon and press the two-color key.

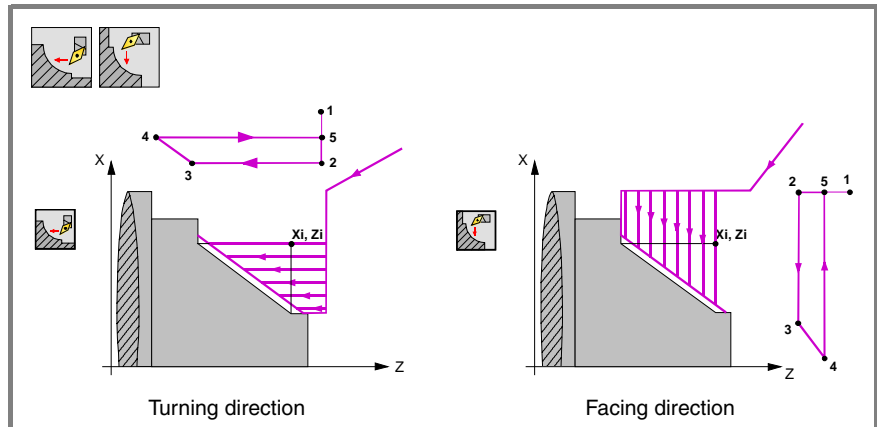

When changing the machining direction, the CNC changes the icon and shows the corresponding help screen.

## Finishing stocks in X-Z.

Either a single residual stock may be defined that is applied depending on the cutter's edge or 2 different ones, one for each axis (X, Z). It is selected with the following icon located in the finishing area.

- The figure on the left applies a finishing stock depending on the cutter's edge. The finishing stock is measured on the tool's cutting edge.
- The figure on the right lets define 2 finishing stocks, one per axis, regardless of the type of tool used.

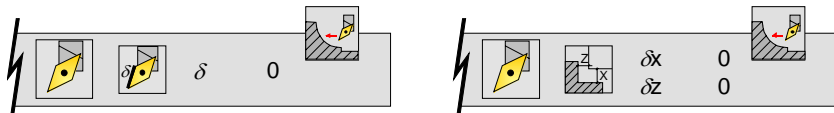

To select the type of finishing stocks, place the cursor over this icon and press the two-color key. To define these residual stocks, place the cursor on the corresponding data, key in the desired value and press [ENTER].



CNC 8055  
CNC 8055i

-TC- OPTION  
(SOFT: V16.1X)



### 3.6.2 Basic operation

The machining steps for this cycle are:

1. If the roughing operation has been programmed with another tool, the CNC will change the tool and will move to the change position if so required by the machine.
2. The spindle starts at the selected speed and in the indicated direction.
3. The tool approaches in rapid to the theoretical corner keeping the selected safety distance in X and Z.

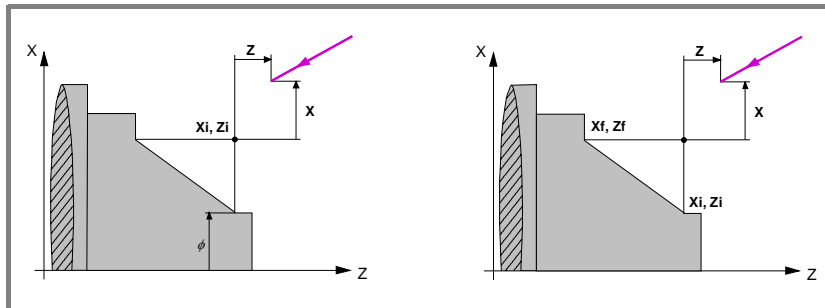

4. Roughing operation, with successive passes, up to a distance from the selected profile equal to the finishing stock.

This operation is carried out with the conditions set for the roughing operations; however, the CNC calculates the actual (real) pass so all the facing passes are identical. This pass will be equal to or smaller than the one defined  $\Delta$ .

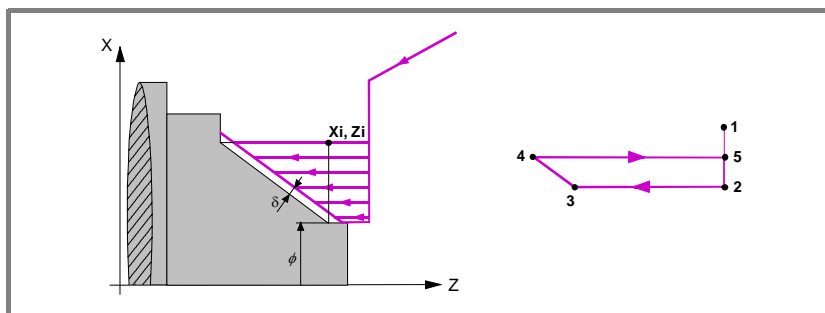

Each machining pass is done as shown in the figure, starting at point "1" and after going through points "2", "3" and "4", ending at point "5".

5. Finishing operation.

If the finishing operation has been programmed with another tool, the CNC will change the tool and will move to the change position if so required by the machine.

The finishing of the part is carried out with the machining conditions set for finishing; feedrate of the axes (F), spindle speed (S) and turning direction.

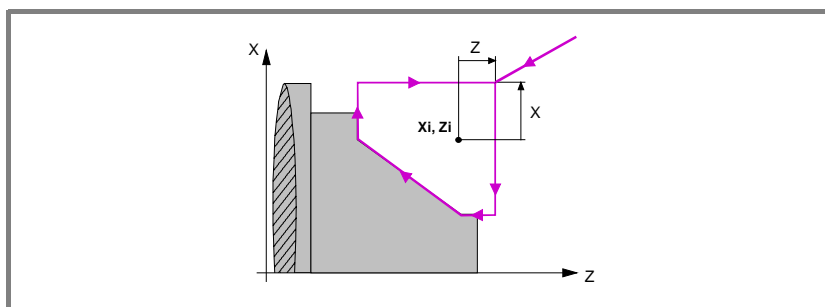

6. Once the operation or cycle has ended, the tool will return to the position it occupied when calling the cycle; i.e. to the point where [START] was pressed.

When executing an entire part, combination of operations or cycles, the tool does not return to that point after executing each cycle.

7. The CNC stops the spindle, but it keeps the machining conditions set for finishing; tool (T), feedrate of the axes (F) and spindle speed (S).

3.

WORKING WITH OPERATIONS OR CYCLES  
Taper turning cycle



CNC 8055  
CNC 8055i

.TC- OPTION  
(SOFT: V16.1X)

## Considerations

---

### How to leave out the roughing or finishing operations.

By selecting T0 as the roughing tool, the cycle does not execute the roughing operation. In other words, after the approach movement, it will carry out the finishing operation.

By selecting T0 as the finishing tool, the cycle does not execute the finishing operation. In other words, after the roughing operation, the tool will move to the approach point maintaining the safety distance from the theoretical corner.

3.

WORKING WITH OPERATIONS OR CYCLES  
Taper turning cycle



CNC 8055  
CNC 8055i

-TC- OPTION  
(SOFT: V16.1X)

## 3.7 Rounding cycle



This key accesses the rounding cycles.

This cycle may be defined in two ways:

### Level 1.

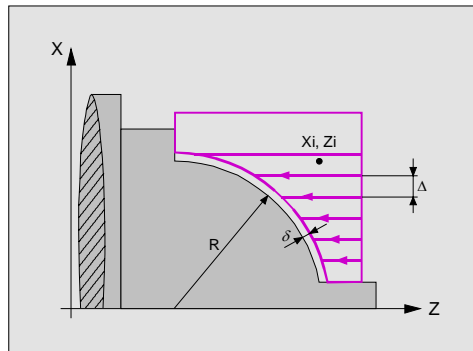

The following data must be defined:

- The coordinates of the theoretical corner.
- The rounding radius.

### Level 2.

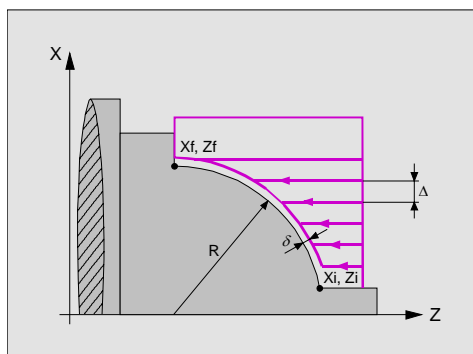

The following data must be defined:

- Coordinates of the starting point.
- Coordinates of the last point.
- The rounding radius.

3.

WORKING WITH OPERATIONS OR CYCLES  
Rounding cycle

FAGOR 

CNC 8055  
CNC 8055i

.TC- OPTION  
(SoFT: V16.1x)

### 3.7.1 Definition of geometry

#### Type of rounding.



To select the type of rounding, place the cursor over this icon and press the two-color key.



Inside rounding.



Outside rounding.

When changing the type of rounding, the CNC changes the icon and shows the corresponding help screen.

#### Concave and convex rounding.



The type of section before and after the rounding section is defined with the following icons. To select the desired type, place the cursor over this icon and press the two-color key.

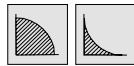

Convex rounding / concave rounding.

When changing one of them, the CNC changes the icon and shows the corresponding help screen.

#### Shape of the part before and after the rounded section.



The type of section before and after the rounding section is defined with the following icons. To select the desired type, place the cursor over this icon and press the two-color key.

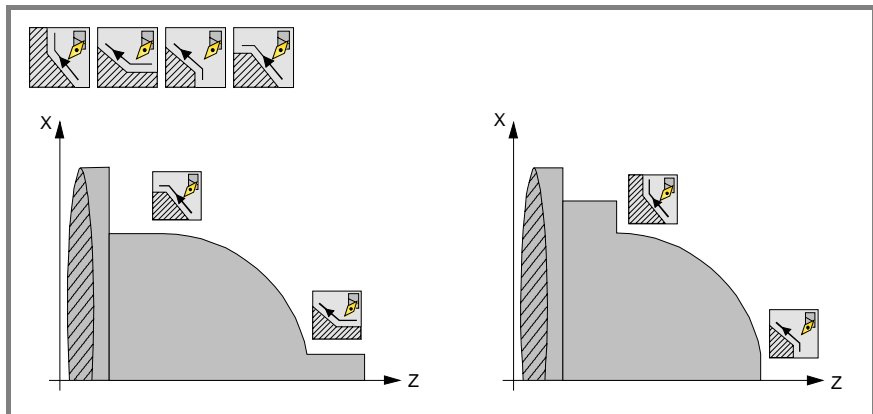

When changing the type of section, the CNC changes the icon and shows the corresponding help screen.

3.

WORKING WITH OPERATIONS OR CYCLES  
Rounding cycle



CNC 8055  
CNC 8055i

-TC- OPTION  
(SOFT: V16.1X)

### Work quadrant.



The work quadrant is defined with the following icons: To select the desired type, place the cursor over this icon and press the two-color key.

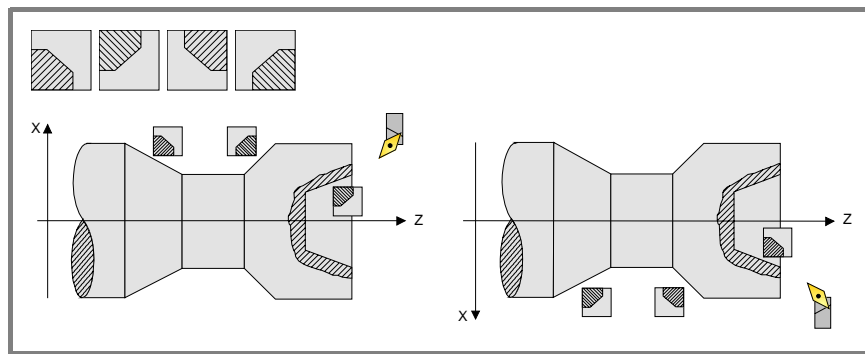

### Coordinates of the theoretical corner or coordinates of the first point ( $X_i, Z_i$ ) and of the last point ( $X_f, Z_f$ ).

The coordinates are defined one by one. After placing the cursor on the coordinates of the axes to be defined, the value is entered in one of the following ways.

- Entering the value manually. Key in the desired value and press [ENTER].
- Assign the current machine position.

Jog the axis with the handwheel or the JOG keys up to the desired point. Press [RECALL] so the selected data assumes the value shown in the top right window and press [ENTER].

The top right window shows the tool position at all times.

### Rounding radius (R).

Place the cursor on this data, key in the desired value and press [ENTER].

### Safety distance.

A part approach point may be set to prevent the tool from colliding with the part. The safety distance indicates the position of the approach point referred to the theoretical corner.

To change one of these values, place the cursor on the corresponding data, key in the desired value and press [ENTER].

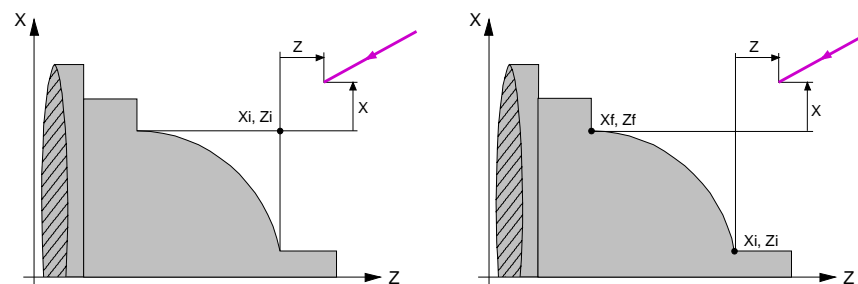

The safety distance in X is always defined in radius.

# 3.

WORKING WITH OPERATIONS OR CYCLES  
Rounding cycle



CNC 8055  
CNC 8055i

.TC- OPTION  
(SOFT: V16.1X)

# 3.

WORKING WITH OPERATIONS OR CYCLES

Rounding cycle

### Machining direction.



The machining direction (turning direction or facing direction) is defined with the following icons. To select the desired type, place the cursor over this icon and press the two-color key.

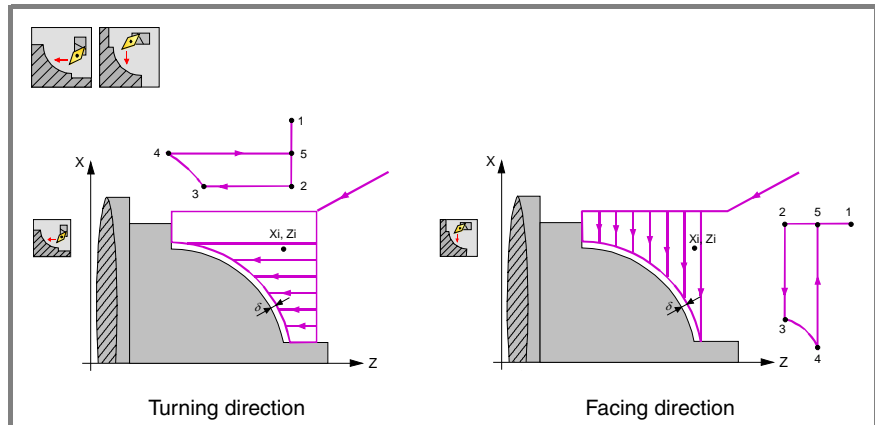

When changing the machining direction, the CNC changes the icon and shows the corresponding help screen.

### Finishing stocks in X-Z.

Either a single residual stock may be defined that is applied depending on the cutter's edge or 2 different ones, one for each axis (X, Z). It is selected with the following icon located in the finishing area.

- The figure on the left applies a finishing stock depending on the cutter's edge. The finishing stock is measured on the tool's cutting edge.
- The figure on the right lets define 2 finishing stocks, one per axis, regardless of the type of tool used.

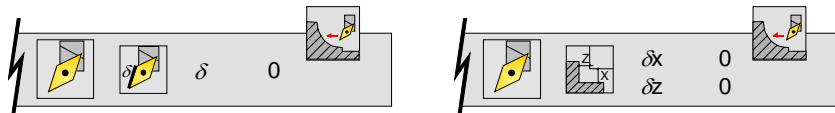

To select the type of finishing stocks, place the cursor over this icon and press the two-color key. To define these residual stocks, place the cursor on the corresponding data, key in the desired value and press [ENTER].



CNC 8055  
CNC 8055i

.TC- OPTION  
(SOFT: V16.1X)

### 3.7.2 Basic operation

The machining steps for this cycle are:

1. If the roughing operation has been programmed with another tool, the CNC will change the tool and will move to the change position if so required by the machine.
2. The spindle starts at the selected speed and in the indicated direction.
3. The tool approaches in rapid to the theoretical corner keeping the selected safety distance in X and Z.

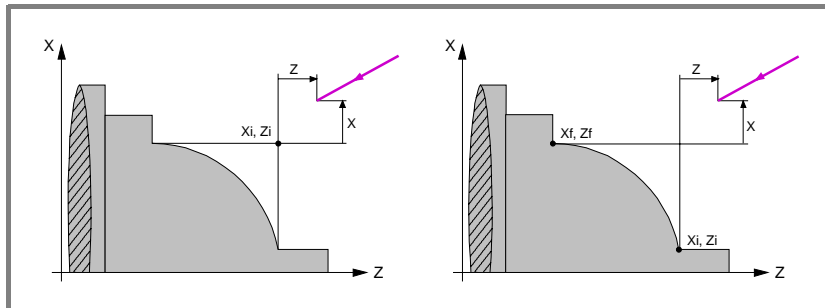

4. Roughing operation, with successive passes, up to a distance from the selected profile equal to the finishing stock.

This operation is carried out with the conditions set for the roughing operations; however, the CNC calculates the actual (real) pass so all the facing passes are identical. This pass will be equal to or smaller than the one defined  $\Delta$ .

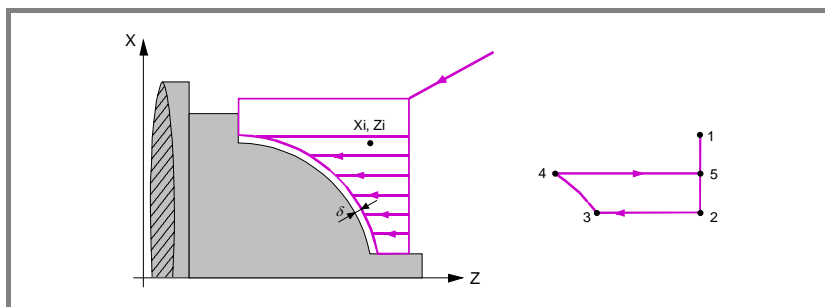

Each machining pass is done as shown in the figure, starting at point "1" and after going through points "2", "3" and "4", ending at point "5".

5. Finishing operation.

If the finishing operation has been programmed with another tool, the CNC will change the tool and will move to the change position if so required by the machine.

The finishing of the part is carried out with the machining conditions set for finishing; feedrate of the axes (F), spindle speed (S) and turning direction.

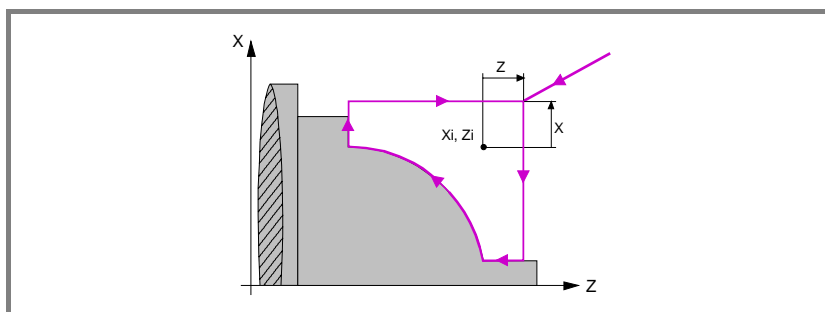

6. Once the operation or cycle has ended, the tool will return to the position it occupied when calling the cycle; i.e. to the point where [START] was pressed.

When executing an entire part, combination of operations or cycles, the tool does not return to that point after executing each cycle.

7. The CNC stops the spindle, but it keeps the machining conditions set for finishing; tool (T), feedrate of the axes (F) and spindle speed (S).

3.

WORKING WITH OPERATIONS OR CYCLES  
Rounding cycle

FAGOR

CNC 8055  
CNC 8055i

.TC- OPTION  
(SOFT: V16.1X)

## Considerations

---

### How to leave out the roughing or finishing operations.

By selecting T0 as the roughing tool, the cycle does not execute the roughing operation. In other words, after the approach movement, it will carry out the finishing operation.

By selecting T0 as the finishing tool, the cycle does not execute the finishing operation. In other words, after the roughing operation, the tool will move to the approach point maintaining the safety distance from the theoretical corner.

3.

WORKING WITH OPERATIONS OR CYCLES  
Rounding cycle



CNC 8055  
CNC 8055i

.TC· OPTION  
(SOFT: V16.1X)



### 3.8 Threading cycle



This key accesses the threading cycles.

This cycle may be defined in several ways:

#### Level 1. Longitudinal threadcutting.

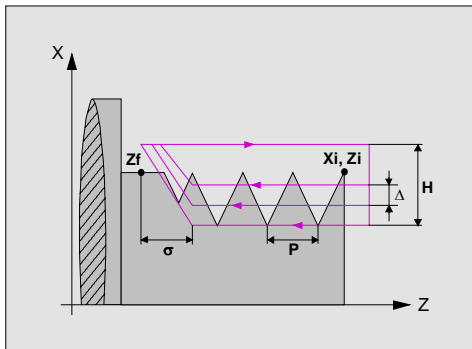

The following data must be defined:

- Coordinates of the starting point.
- Z coordinate of the last point.
- The thread pitch.
- Thread type (variable pitch or fixed pitch).
- The distance to the end of the thread.
- The total depth.
- The spindle angular position.
- The distance to the end of the thread.

#### Level 2. Taper thread.

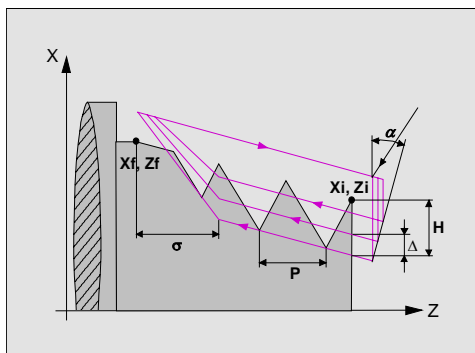

The following data must be defined:

- Coordinates of the starting point.
- Coordinates of the last point.
- The thread pitch.
- Thread type (variable pitch or fixed pitch).
- The distance to the end of the thread.
- The total depth.
- The spindle angular position.
- The distance to the end of the thread.

3.

WORKING WITH OPERATIONS OR CYCLES  
Threading cycle



CNC 8055  
CNC 8055i

.TC- OPTION  
(SOFT: V16.1x)

# 3.

WORKING WITH OPERATIONS OR CYCLES  
Threading cycle

### Level 3. Face tapping.

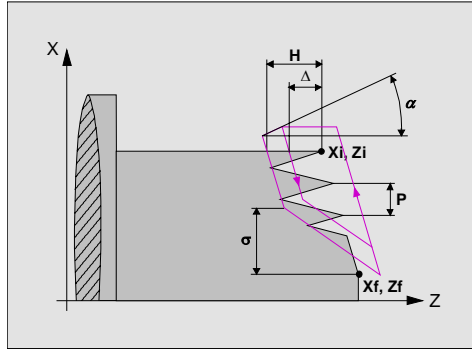

The following data must be defined:

- Coordinates of the starting point.
- Coordinates of the last point.
- The thread pitch.
- The distance to the end of the thread.
- The total depth.
- The spindle angular position.
- The distance to the end of the thread.

### Level 4. Thread repair.

Available when setting spindle machine parameter "M19TYPE (P43)=1".

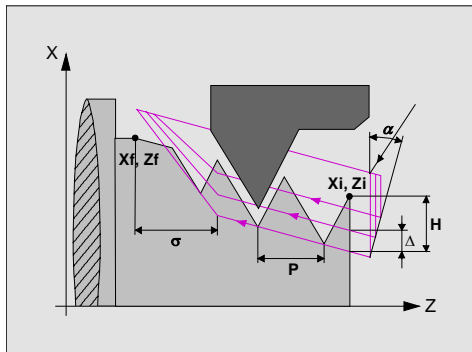

The following data must be defined:

- Coordinates of the starting point.
- Coordinates of the last point.
- The thread pitch.
- The distance to the end of the thread.
- The total depth.
- Z coordinate of the valley (root).
- The spindle angular position at the valley (root).
- The distance to the end of the thread.



CNC 8055  
CNC 8055i

-TC- OPTION  
(SOFT: V16.1X)

### Level 5. Threads with several entries.

Available when setting spindle machine parameter "M19TYPE (P43)=1".

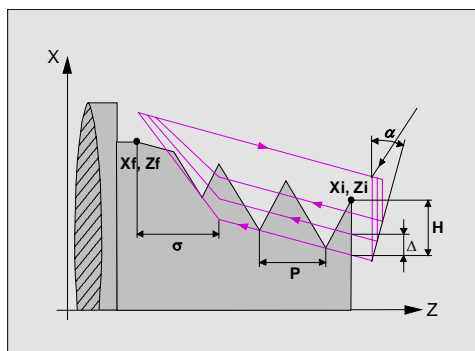

- Coordinates of the starting point.
- Coordinates of the last point.
- The thread pitch.
- Thread type (variable pitch or fixed pitch).
- The distance to the end of the thread.
- The total depth.
- Z coordinate of the valley (root).
- The spindle angular position at the valley (root).
- The number of thread entries.
- The distance to the end of the thread.

3.

WORKING WITH OPERATIONS OR CYCLES  
Threading cycle

FAGOR 

CNC 8055  
CNC 8055i

.TC· OPTION  
(SOFT: V16.1X)

### 3.8.1 Definition of geometry

#### **Type of tapping.**



To select the type of tapping, place the cursor over this icon and press the two-color key.



Inside threading.



Outside threading.

When changing the type of threading, the CNC changes the icon and shows the corresponding help screen.

#### **Coordinates of the first point (Xi, Zi) and of the last point (Xf, Zf).**

The coordinates are defined one by one. After placing the cursor on the coordinates of the axes to be defined, the value is entered in one of the following ways.

- Entering the value manually. Key in the desired value and press [ENTER].
- Assign the current machine position.

Jog the axis with the handwheel or the JOG keys up to the desired point. Press [RECALL] so the selected data assumes the value shown in the top right window and press [ENTER].

The top right window shows the tool position at all times.

#### **Standard threads.**

Up to 6 standard thread types may be selected. See "[3.8.2 Standard threads](#)" on page 100.

M (S.I.)	Regular pitch metric thread (international system).
M (S.I.F.)	Fine pitch metric thread (international system).
B.S.W. (W)	Regular pitch Whitworth thread.
B.S.F.	Fine pitch Whitworth thread.
U.N.C.	Regular pitch unified American thread.
U.N.F.	Fine pitch unified American thread.

When selecting one of them, the pitch and depth of the thread are calculated automatically; if none is selected, the pitch and depth of the thread must be defined.

#### **Defining the thread as number of threads per inch.**

In any threading cycle, the thread pitch may be entered as number of threads per inch. This may be done regardless of whether it is working in millimeters or in inches.

To define the thread as number of threads per inch, instead of selecting the standard thread, select a free thread and press [ENTER]. In the following data, use the [-] key, select "Threads/inch" and press [ENTER]. Then, place the cursor on the P data, key in the desired value and press [ENTER].

#### **Total depth of the thread (H).**

The total depth must be programmed in radius and with a positive value. To define that value, place the cursor on this data, key in the desired value and press [ENTER].

#### **Number of entries (N).**

To define that value, place the cursor on this data, key in the desired value and press [ENTER].

**3.**

WORKING WITH OPERATIONS OR CYCLES  
Threading cycle



CNC 8055  
CNC 8055i

.TC- OPTION  
(SOFT: V16.1X)

### Thread pitch (P).

The thread pitch may be defined along the inclination of the thread or along the associated axis. In either case, parameter "P" is used, but with a different sign.

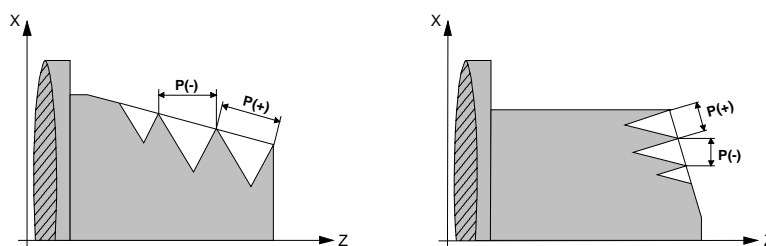

- "P" with a positive sign to program the pitch is programmed along the inclination of the thread.
- "P" with a negative sign to program the pitch along the associated axis.

To define the pitch, place the cursor on this data, key in the desired value and press [ENTER].



### Thread type

Icon to select the type of thread to make (with constant pitch or with variable pitch)

### Increment/decrement of thread pitch ( $\Delta P$ )

It defines the thread pitch increment or decrement per spindle revolution.



*It must be borne in mind that if a thread pitch decrement is programmed and the pitch reaches 0 before the end of the thread cutting operation, the CNC will display the corresponding error message.*

### Distance to the end of the thread ( $\sigma$ ).

This parameter indicates at what distance from the end of the thread the tool starts exiting it. It keeps threading during this exit movement. Place the cursor on this data, key in the desired value and press [ENTER].

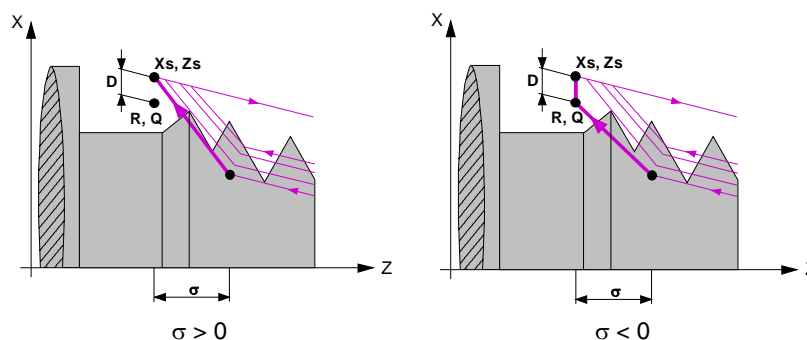

- If programmed with a positive value, the tool exits the thread without going through the final point ( $X_f, Z_f$ ).
- If programmed with a negative value, the tool exits the thread going through the final point ( $X_f, Z_f$ ).

3.

WORKING WITH OPERATIONS OR CYCLES  
Threading cycle



CNC 8055  
CNC 8055i

.TC- OPTION  
(SOFT: V16.1X)

# 3.

WORKING WITH OPERATIONS OR CYCLES  
Threading cycle

- If not programmed, a value of 0 is assumed (blind thread).

The third set of gains and accelerations for the axes and the spindle may be used to improve the adjustment and the machining of the exit from blind threads. If the thread exit is a short distance, any acceleration set may be used or even remove the acceleration without getting the error "insufficient acceleration while threading".

We recommend to use low or no acceleration.

### Safety distance.

A part approach point may be set to prevent the tool from colliding with the part. The safety distance indicates the position of the approach point referred to the theoretical corner.

To change one of these values, place the cursor on the corresponding data, key in the desired value and press [ENTER].

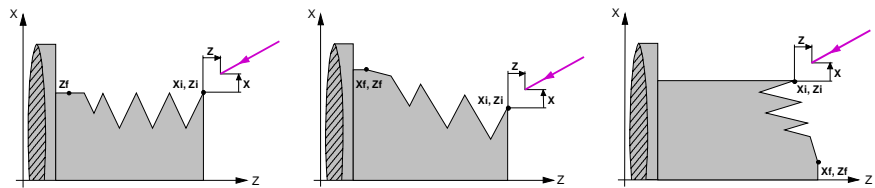

The safety distance in X is always defined in radius.

### Spindle angular position.

In the thread repair cycle, this parameter indicates the angular position of the spindle at the root (valley) and must be programmed together with the "Z coordinate of the valley (root)" as described later on.

On the rest of the levels, programming this data is optional and it indicates the angular position of the spindle or angle with respect to the reference mark where the threading must begin. It may be used to make multi-entry threads without having to back off the starting point.



To select whether the entry angle must be defined or not, place the cursor over this icon and press the two-color key.



Threading without programming the entry angle.



W 0.0000

Threading programming the entry angle.



CNC 8055  
CNC 8055i

.TC. OPTION  
(SOFT: V16.1X)

### Depth of the successive threading passes ( $\Delta$ ).



The  $\Delta$  data sets the maximum penetration pass and the following icons define how the successive machining passes are run. To select the type of pass depth, place the cursor over this icon and press the two-color key.



The depth of each pass will depend on the number of the corresponding pass. The penetrations are  $\Delta$ ,  $\Delta\sqrt{2}$ ,  $\Delta\sqrt{3}$ ,  $\Delta\sqrt{4}$ , etc.

If the penetration increment (different between penetrations) calculated by the CNC is smaller than the minimum penetration increment, the CNC assumes this last value.



The penetration increment is kept constant between passes with a value equal to the one programmed  $\Delta$ .

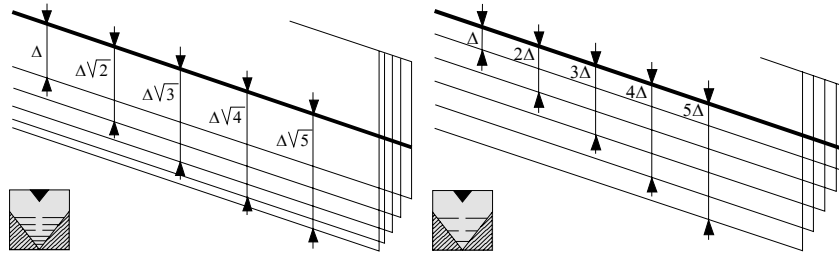

For the level 1 threading cycle, the depth of each pass depends on the corresponding pass number ( $\Delta$ ,  $\Delta\sqrt{2}$ ,  $\Delta\sqrt{3}$ ,  $\Delta\sqrt{4}$ , etc.).

### Type of tool penetration.



To select the type of tool penetration, place the cursor over this icon and press the two-color key.



Radial penetration.



Flank penetration.



Zig-zag penetration.

When selecting the flank type penetration or in zig-zag, the CNC will request the cutter's penetration angle ( $\alpha$ ).

For the level 1 threading cycle, the type of penetration is always radial.

### Repeat the last threading pass.



To select whether to repeat the last pass or not, place the cursor over this icon and press the two-color key.



Do not repeat the last pass.



Repeat the last pass.

# 3.

WORKING WITH OPERATIONS OR CYCLES  
Threading cycle



CNC 8055  
CNC 8055i

.TC- OPTION  
(SOFT: V16.1X)

### 3.8.2 Standard threads

At all the levels except in face threading, the diameter value may be entered so the CNC calculates the relevant pitch and depths.

A new field (window) may be used to select the type of standard thread; if none is selected, the pitch and depth of the thread must be defined.

The available thread types are:

M (S.I.)	Regular pitch metric thread (international system).
M (S.I.F.)	Fine pitch metric thread (international system).
B.S.W. (W)	Regular pitch Whitworth thread.
B.S.F.	Fine pitch Whitworth thread.
U.N.C.	Regular pitch unified American thread.
U.N.F.	Fine pitch unified American thread.

**3.**

**WORKING WITH OPERATIONS OR CYCLES**  
Threading cycle



CNC 8055  
CNC 8055i

-TC- OPTION  
(SOFT: V16.1X)



### Regular pitch metric thread: M (S.I.)

Diameter		Pitch		Depth (mm)	
(mm)	(inches)	(mm)	(inches)	Internal	External
0,3000	0,0118	0,0750	0,0030	0,0406	0,0460
0,4000	0,0157	0,1000	0,0039	0,0541	0,0613
0,5000	0,0197	0,1250	0,0049	0,0677	0,0767
0,6000	0,0236	0,1500	0,0059	0,0812	0,0920
0,8000	0,0315	0,2000	0,0079	0,1083	0,1227
1,0000	0,0394	0,2500	0,0098	0,1353	0,1534
1,2000	0,0472	0,2500	0,0098	0,1353	0,1534
1,4000	0,0551	0,3000	0,0118	0,1624	0,1840
1,6000	0,0630	0,3500	0,0138	0,1895	0,2147
1,7000	0,0669	0,3500	0,0138	0,1895	0,2147
1,8000	0,0709	0,3500	0,0138	0,1895	0,2147
2,0000	0,0787	0,4000	0,0157	0,2165	0,2454
2,2000	0,0866	0,4500	0,0177	0,2436	0,2760
2,3000	0,0906	0,4000	0,0157	0,2165	0,2454
2,5000	0,0984	0,4500	0,0177	0,2436	0,2760
2,6000	0,1024	0,4500	0,0177	0,2436	0,2760
3,0000	0,1181	0,5000	0,0197	0,2707	0,3067
3,5000	0,1378	0,6000	0,0236	0,3248	0,3680
4,0000	0,1575	0,7000	0,0276	0,3789	0,4294
4,5000	0,1772	0,7500	0,0295	0,4060	0,4601
5,0000	0,1969	0,8000	0,0315	0,4330	0,4907
5,5000	0,2165	0,9000	0,0354	0,4872	0,5521
6,0000	0,2362	1,0000	0,0394	0,5413	0,6134
7,0000	0,2756	1,0000	0,0394	0,5413	0,6134
8,0000	0,3150	1,2500	0,0492	0,6766	0,7668
9,0000	0,3543	1,2500	0,0492	0,6766	0,7668
10,0000	0,3937	1,5000	0,0591	0,8120	0,9201
11,0000	0,4331	1,5000	0,0591	0,8120	0,9201
12,0000	0,4724	1,7500	0,0689	0,9473	1,0735
14,0000	0,5512	2,0000	0,0787	1,0826	1,2268
16,0000	0,6299	2,0000	0,0787	1,0826	1,2268
18,0000	0,7087	2,5000	0,0984	1,3533	1,5335
20,0000	0,7874	2,5000	0,0984	1,3533	1,5335
22,0000	0,8661	2,5000	0,0984	1,3533	1,5335
24,0000	0,9449	3,0000	0,1181	1,6239	1,8402
27,0000	1,0630	3,0000	0,1181	1,6239	1,8402
30,0000	1,1811	3,5000	0,1378	1,8946	2,1469
33,0000	1,2992	3,5000	0,1378	1,8946	2,1469
36,0000	1,4173	4,0000	0,1575	2,1652	2,4536
39,0000	1,5354	4,0000	0,1575	2,1652	2,4536
42,0000	1,6535	4,5000	0,1772	2,4359	2,7603
45,0000	1,7717	4,5000	0,1772	2,4359	2,7603
48,0000	1,8898	5,0000	0,1969	2,7065	3,0670
52,0000	2,0472	5,0000	0,1969	2,7065	3,0670
56,0000	2,2047	5,5000	0,2165	2,9772	3,3737
60,0000	2,3622	5,5000	0,2165	2,9772	3,3737
64,0000	2,5197	6,0000	0,2362	3,2478	3,6804
68,0000	2,6772	6,0000	0,2362	3,2478	3,6804
72,0000	2,8346	6,0000	0,2362	3,2478	3,6804
76,0000	2,9921	6,0000	0,2362	3,2478	3,6804
80,0000	3,1496	6,0000	0,2362	3,2478	3,6804

Depth in internal threads = 0.5413 x Pitch

Depth in external threads = 0.6134 x Pitch

# 3.

WORKING WITH OPERATIONS OR CYCLES  
Threading cycle



CNC 8055  
CNC 8055i

.TC- OPTION  
(Soft: V16.1x)

**Fine pitch metric thread: M (S.I.F.)**

**3.**

**WORKING WITH OPERATIONS OR CYCLES**  
Threading cycle

Diameter		Pitch		Depth (mm)	
(mm)	(inches)	(mm)	(inches)	Internal	External
1,000	0,0394	0,2000	0,0079	0,1083	0,1227
1,200	0,0472	0,2000	0,0079	0,1083	0,1227
1,400	0,0551	0,2000	0,0079	0,1083	0,1227
1,700	0,0669	0,2000	0,0079	0,1083	0,1227
2,000	0,0787	0,2500	0,0098	0,1353	0,1534
2,300	0,0906	0,2500	0,0098	0,1353	0,1534
2,500	0,0984	0,3500	0,0138	0,1895	0,2147
2,600	0,1024	0,3500	0,0138	0,1895	0,2147
3,000	0,1181	0,3500	0,0138	0,1895	0,2147
3,500	0,1378	0,3500	0,0138	0,1895	0,2147
4,000	0,1575	0,5000	0,0197	0,2707	0,3067
4,500	0,1772	0,5000	0,0197	0,2707	0,3067
5,000	0,1969	0,5000	0,0197	0,2707	0,3067
6,000	0,2362	0,7500	0,0295	0,4060	0,4601
7,000	0,2756	0,7500	0,0295	0,4060	0,4601
8,000	0,3150	1,0000	0,0394	0,5413	0,6134
9,000	0,3543	1,0000	0,0394	0,5413	0,6134
10,000	0,3937	1,0000	0,0394	0,5413	0,6134
12,000	0,4724	1,2500	0,0492	0,6766	0,7668
13,000	0,5118	1,5000	0,0591	0,8120	0,9201
14,000	0,5512	1,5000	0,0591	0,8120	0,9201
16,000	0,6299	1,5000	0,0591	0,8120	0,9201
18,000	0,7087	1,5000	0,0591	0,8120	0,9201
20,000	0,7874	1,5000	0,0591	0,8120	0,9201
22,000	0,8661	1,5000	0,0591	0,8120	0,9201
24,000	0,9449	2,0000	0,0787	1,0826	1,2268
27,000	1,0630	2,0000	0,0787	1,0826	1,2268
30,000	1,1811	2,0000	0,0787	1,0826	1,2268
33,000	1,2992	2,0000	0,0787	1,0826	1,2268
36,000	1,4173	3,0000	0,1181	1,6239	1,8402
39,000	1,5354	3,0000	0,1181	1,6239	1,8402
42,000	1,6535	3,0000	0,1181	1,6239	1,8402
45,000	1,7717	3,0000	0,1181	1,6239	1,8402
48,000	1,8898	3,0000	0,1181	1,6239	1,8402
52,000	2,0472	3,0000	0,1181	1,6239	1,8402
56,000	2,2047	4,0000	0,1575	2,1652	2,4536
60,000	2,3622	4,0000	0,1575	2,1652	2,4536
64,000	2,5197	4,0000	0,1575	2,1652	2,4536
68,000	2,6772	4,0000	0,1575	2,1652	2,4536
72,000	2,8346	4,0000	0,1575	2,1652	2,4536
76,000	2,9921	4,0000	0,1575	2,1652	2,4536
80,000	3,1496	4,0000	0,1575	2,1652	2,4536

Depth in internal threads = 0.5413 x Pitch

Depth in external threads = 0.6134 x Pitch



CNC 8055  
CNC 8055i

.TC- OPTION  
(SoFT: V16.1x)

### Whitworth thread with normal pitch: B.S.W. (W)

	Thread		Edges	Pitch		Depth (mm)	
	(mm)	(inches)		(mm)	(inches)	Internal	External
1/16	1,5875	0,0625	60	0,4233	0,0167	0,2710	0,2710
3/32	2,3812	0,0937	48	0,5292	0,0208	0,3388	0,3388
1/8	3,1750	0,1250	40	0,6350	0,0250	0,4066	0,4066
5/32	3,9687	0,1562	32	0,7938	0,0313	0,5083	0,5083
3/16	4,7625	0,1875	24	1,0583	0,0417	0,6776	0,6776
7/32	5,5562	0,2187	24	1,0583	0,0417	0,6776	0,6776
1/4	6,3500	0,2500	20	1,2700	0,0500	0,8132	0,8132
5/16	7,9375	0,3125	18	1,4111	0,0556	0,9035	0,9035
3/8	9,5250	0,3750	16	1,5875	0,0625	1,0165	1,0165
7/16	11,1125	0,4375	14	1,8143	0,0714	1,1617	1,1617
1/2	12,7000	0,5000	12	2,1167	0,0833	1,3553	1,3553
9/16	14,2875	0,5625	12	2,1167	0,0833	1,3553	1,3553
5/8	15,8750	0,6250	11	2,3091	0,0909	1,4785	1,4785
3/4	19,0500	0,7500	10	2,5400	0,1000	1,6264	1,6264
7/8	22,2250	0,8750	9	2,8222	0,1111	1,8071	1,8071
1	25,4000	1,0000	8	3,1750	0,1250	2,0330	2,0330
1 1/8	28,5750	1,1250	7	3,6286	0,1429	2,3234	2,3234
1 1/4	31,7500	1,2500	7	3,6286	0,1429	2,3234	2,3234
1 3/8	34,9250	1,3750	6	4,2333	0,1667	2,7106	2,7106
1 1/2	38,1000	1,5000	6	4,2333	0,1667	2,7106	2,7106
1 5/8	41,2750	1,6250	5	5,0800	0,2000	3,2527	3,2527
1 3/4	44,4500	1,7500	5	5,0800	0,2000	3,2527	3,2527
1 7/8	47,6250	1,8750	5	5,6444	0,2222	3,6141	3,6141
2	50,8000	2,0000	5	5,6444	0,2222	3,6141	3,6141
2 1/8	53,9750	2,1250	5	5,6444	0,2222	3,6141	3,6141
2 1/4	57,1500	2,2500	4	6,3500	0,2500	4,0659	4,0659
2 3/8	60,3250	2,3750	4	6,3500	0,2500	4,0659	4,0659
2 1/2	63,5000	2,5000	4	6,3500	0,2500	4,0659	4,0659
2 5/8	66,6750	2,6250	4	6,3500	0,2500	4,0659	4,0659
2 3/4	69,8500	2,7500	4	7,2571	0,2857	4,6467	4,6467
2 7/8	73,0250	2,8750	4	7,2571	0,2857	4,6467	4,6467
3	76,2000	3,0000	4	7,2571	0,2857	4,6467	4,6467
3 1/4	82,5500	3,2500	3	7,8154	0,3077	5,0042	5,0042
3 1/2	88,9000	3,5000	3	7,8154	0,3077	5,0042	5,0042
3 3/4	95,2500	3,7500	3	8,4667	0,3333	5,4212	5,4212
4	101,6000	4,0000	3	8,4667	0,3333	5,4212	5,4212
4 1/4	107,9500	4,2500	3	8,8348	0,3478	5,6569	5,6569
4 1/2	114,3000	4,5000	3	8,8348	0,3478	5,6569	5,6569
4 3/4	120,6500	4,7500	3	9,2364	0,3636	5,9141	5,9141
5	127,0000	5,0000	3	9,2364	0,3636	5,9141	5,9141

The threads must be defined in mm or inches. For example, to define a Whitworth thread with a 1/16 pitch, enter 1.5875 mm or 0.0625 inches.

The CNC calculates the pitch and the depth with the formulae:

Pitch in mm = 25.4 / number of edges

Pitch in inches = 1 / number of edges

Depth in internal threads = 0.6403 x Pitch

Depth in external threads = 0.6403 x Pitch

# 3.

WORKING WITH OPERATIONS OR CYCLES  
Threading cycle



CNC 8055  
CNC 8055i

.TC- OPTION  
(SOFT: V16.1x)

### Whitworth thread with fine pitch: B.S.F

# 3.

**WORKING WITH OPERATIONS OR CYCLES**  
 Threading cycle

	Thread		Edges	Pitch		Depth (mm)	
	(mm)	(inches)		(mm)	(inches)	Internal	External
3/16	4,7625	0,1875	32	0,7937	0,0312	0,5082	0,5082
7/32	5,5562	0,2187	28	0,9071	0,0357	0,5808	0,5808
1/4	6,3500	0,2500	26	0,9769	0,0385	0,6255	0,6255
9/32	7,1437	0,2812	26	0,9769	0,0385	0,6255	0,6255
5/16	7,9375	0,3125	22	1,1545	0,0455	0,7392	0,7392
3/8	9,5250	0,3750	20	1,2700	0,0500	0,8132	0,8132
7/16	11,1125	0,4375	18	1,4111	0,0556	0,9035	0,9035
1/2	12,7000	0,5000	16	1,5875	0,0625	1,0165	1,0165
9/16	14,2875	0,5625	16	1,5875	0,0625	1,0165	1,0165
5/8	15,8750	0,6250	14	1,8143	0,0714	1,1617	1,1617
11/16	17,4625	0,6875	14	1,8143	0,0714	1,1617	1,1617
3/4	19,0500	0,7500	12	2,1167	0,0833	1,3553	1,3553
13/16	20,6375	0,8125	12	2,1167	0,0833	1,3553	1,3553
7/8	22,2250	0,8750	11	2,3091	0,0909	1,4785	1,4785
1	25,4000	1,0000	10	2,5400	0,1000	1,6264	1,6264
1 1/8	28,5750	1,1250	9	2,8222	0,1111	1,8071	1,8071
1 1/4	31,7500	1,2500	9	2,8222	0,1111	1,8071	1,8071
1 3/8	34,9250	1,3750	8	3,1750	0,1250	2,0330	2,0330
1 1/2	38,1000	1,5000	8	3,1750	0,1250	2,0330	2,0330
1 5/8	41,2750	1,6250	8	3,1750	0,1250	2,0330	2,0330
1 3/4	44,4500	1,7500	7	3,6286	0,1429	2,3234	2,3234
2	50,8000	2,0000	7	3,6286	0,1429	2,3234	2,3234
2 1/4	57,1500	2,2500	6	4,2333	0,1667	2,7106	2,7106
2 1/2	63,5000	2,5000	6	4,2333	0,1667	2,7106	2,7106
2 3/4	69,8500	2,7500	6	4,2333	0,1667	2,7106	2,7106
3	76,2000	3,0000	5	5,0800	0,2000	3,2527	3,2527

The threads must be defined in mm or inches. For example, to define a Whitworth thread with a 3/16 pitch, enter 4.7625 mm or 0.1875 inches.

The CNC calculates the pitch and the depth with the formulae:

Pitch in mm = 25.4 / number of edges

Pitch in inches = 1 / number of edges

Depth in internal threads = 0.6403 x Pitch

Depth in external threads = 0.6403 x Pitch



CNC 8055  
CNC 8055i

-TC- OPTION  
(SOFT: V16.1x)

## Regular pitch unified American thread: UNC (NC,USS)

	Thread		Edges	Pitch		Depth (mm)	
	(mm)	(inches)		(mm)	(inches)	Internal	External
0,0730	1,8542	0,0730	64	0,3969	0,0156	0,2148	0,2435
0,0860	2,1844	0,0860	56	0,4536	0,0179	0,2455	0,2782
0,0990	2,5146	0,0990	48	0,5292	0,0208	0,2865	0,3246
0,1120	2,8448	0,1120	40	0,6350	0,0250	0,3437	0,3895
0,1250	3,1750	0,1250	40	0,6350	0,0250	0,3437	0,3895
0,1380	3,5052	0,1380	32	0,7938	0,0313	0,4297	0,4869
0,1640	4,1656	0,1640	32	0,7938	0,0313	0,4297	0,4869
0,1900	4,8260	0,1900	24	1,0583	0,0417	0,5729	0,6492
0,2160	5,4864	0,2160	24	1,0583	0,0417	0,5729	0,6492
1/4	6,3500	0,2500	20	1,2700	0,0500	0,6875	0,7790
5/16	7,9375	0,3125	18	1,4111	0,0556	0,7638	0,8656
3/8	9,5250	0,3750	16	1,5875	0,0625	0,8593	0,9738
7/16	11,1125	0,4375	14	1,8143	0,0714	0,9821	1,1129
1/2	12,7000	0,5000	13	1,9538	0,0769	1,0576	1,1985
9/16	14,2875	0,5625	12	2,1167	0,0833	1,1458	1,2984
5/8	15,8750	0,6250	11	2,3091	0,0909	1,2499	1,4164
3/4	19,0500	0,7500	10	2,5400	0,1000	1,3749	1,5580
7/8	22,2250	0,8750	9	2,8222	0,1111	1,5277	1,7311
1	25,4000	1,0000	8	3,1750	0,1250	1,7186	1,9475
1 1/8	28,5750	1,1250	7	3,6286	0,1429	1,9642	2,2258
1 1/4	31,7500	1,2500	7	3,6286	0,1429	1,9642	2,2258
1 3/8	34,9250	1,3750	6	4,2333	0,1667	2,2915	2,5967
1 1/2	38,1000	1,5000	6	4,2333	0,1667	2,2915	2,5967
1 5/8	41,2750	1,6250	5	5,0800	0,2000	2,7498	3,1161
1 3/4	44,4500	1,7500	5	5,0800	0,2000	2,7498	3,1161
2	50,8000	2,0000	5	5,6444	0,2222	3,0553	3,4623
2 1/4	57,1500	2,2500	5	5,6444	0,2222	3,0553	3,4623
2 1/2	63,5000	2,5000	4	6,3500	0,2500	3,4373	3,8951
2 3/4	69,8500	2,7500	4	6,3500	0,2500	3,4373	3,8951
3	76,2000	3,0000	4	6,3500	0,2500	3,4373	3,8951

The threads must be defined in mm or inches. For example, to define an American thread with a 1/4 pitch, enter 6.3500 mm or 0.2500 inches.

The CNC calculates the pitch and the depth with the formulae:

Pitch in mm = 25.4 / number of edges

Pitch in inches = 1 / number of edges

Depth in internal threads = 0.5413 x Pitch

Depth in external threads = 0.6134 x Pitch

# 3.

WORKING WITH OPERATIONS OR CYCLES

Threading cycle



**CNC 8055**  
**CNC 8055i**

-TC- OPTION  
(Soft: V16.1x)

**Fine pitch unified American thread: UNF (NF,SAE)**

**3.**

**WORKING WITH OPERATIONS OR CYCLES**  
Threading cycle

	Thread		Edges	Pitch		Depth (mm)	
	(mm)	(inches)		(mm)	(inches)	Internal	External
0,0600	1,5240	0,0600	80	0,3175	0,0125	0,1719	0,1948
0,0730	1,8542	0,0730	72	0,3528	0,0139	0,1910	0,2164
0,0860	2,1844	0,0860	64	0,3969	0,0156	0,2148	0,2435
0,0990	2,5146	0,0990	56	0,4536	0,0179	0,2455	0,2782
0,1120	2,8448	0,1120	48	0,5292	0,0208	0,2865	0,3246
0,1250	3,1750	0,1250	44	0,5773	0,0227	0,3125	0,3541
0,1380	3,5052	0,1380	40	0,6350	0,0250	0,3437	0,3895
0,1640	4,1656	0,1640	36	0,7056	0,0278	0,3819	0,4328
0,1900	4,8260	0,1900	32	0,7937	0,0312	0,4296	0,4869
19/88	5,4864	0,2160	28	0,9071	0,0357	0,4910	0,5564
1/4	6,3500	0,2500	28	0,9071	0,0357	0,4910	0,5564
5/16	7,9375	0,3125	24	1,0583	0,0417	0,5729	0,6492
3/8	9,5250	0,3750	24	1,0583	0,0417	0,5729	0,6492
7/16	11,1125	0,4375	20	1,2700	0,0500	0,6875	0,7790
1/2	12,7000	0,5000	20	1,2700	0,0500	0,6875	0,7790
9/16	14,2875	0,5625	18	1,4111	0,0556	0,7638	0,8656
5/8	15,8750	0,6250	18	1,4111	0,0556	0,7638	0,8656
3/4	19,0500	0,7500	16	1,5875	0,0625	0,8593	0,9738
7/8	22,2250	0,8750	14	1,8143	0,0714	0,9821	1,1129
1	25,4000	1,0000	12	2,1167	0,0833	1,1458	1,2984
1 1/8	28,5750	1,1250	12	2,1167	0,0833	1,1458	1,2984
1 1/4	31,7500	1,2500	12	2,1167	0,0833	1,1458	1,2984
1 1/2	38,1000	1,5000	12	2,1167	0,0833	1,1458	1,2984

The threads must be defined in mm or inches. For example, to define an American thread with a 1/4 pitch, enter 6.3500 mm or 0.2500 inches.

The CNC calculates the pitch and the depth with the formulae:

Pitch in mm = 25.4 / number of edges

Pitch in inches = 1 / number of edges

Depth in internal threads = 0.5413 x Pitch

Depth in external threads = 0.6134 x Pitch



CNC 8055  
CNC 8055i

-TC- OPTION  
(SOFT: V16.1x)

### 3.8.3 Basic operation. Longitudinal threadcutting

The machining steps for this cycle are:

1. If the operation has been programmed with another tool, the CNC will change the tool and will move to the change position if so required by the machine.
2. The spindle starts at the selected speed and in the indicated direction. Depending on the spindle turning direction, the thread will be clockwise or counterclockwise.
3. The tool approaches in rapid to the theoretical corner keeping the selected safety distance in X and Z.

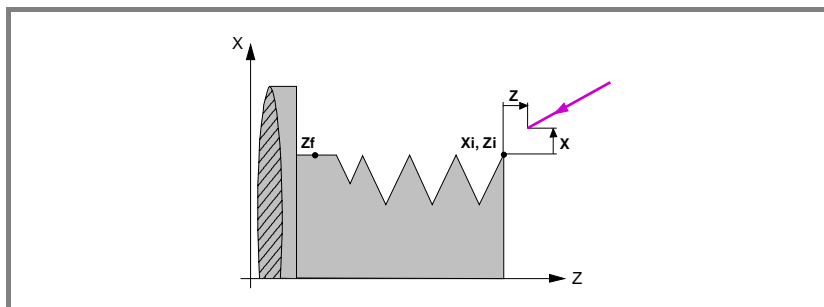

4. The threading is done with radial penetration and in successive passes until the total depth is reached. The depth of each pass depends on the corresponding pass number  $\Delta$ ,  $\Delta\sqrt{2}$ ,  $\Delta\sqrt{3}$ ,  $\Delta\sqrt{4}$ , etc.

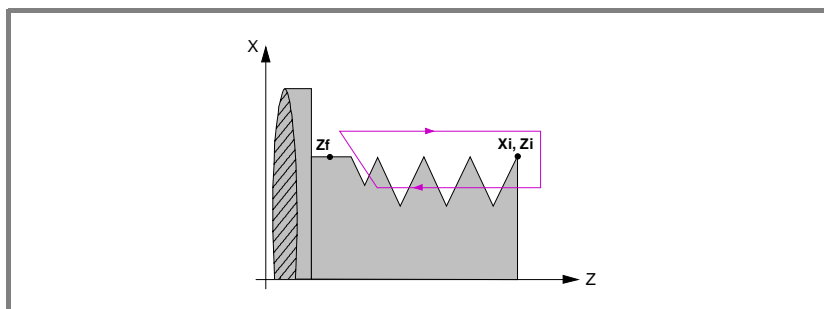

Each threading step is carried out as follows:

- Rapid move to the corresponding programmed depth.
  - Threading of the programmed section, first along the Z up to the distance from the end of the thread ( $\sigma$ ) and then exit threading up to the final coordinate. The feedrate F cannot be varied with the feedrate override switch while threading; it will stay at 100%. At the beginning of the machining operation on large lathes, when cutting long threads, the spindle speed may be overridden in the first passes to prevent the part from bending.
  - Withdrawal in rapid to the approach point.
5. Once the operation or cycle has ended, the tool will return to the position it occupied when calling the cycle; i.e. to the point where [START] was pressed.  
When executing an entire part, combination of operations or cycles, the tool does not return to that point after executing each cycle.
  6. The CNC stops the spindle, but it keeps the machining conditions set; tool (T), feedrate of the axes (F) and spindle speed (S).

3.

WORKING WITH OPERATIONS OR CYCLES  
Threading cycle



CNC 8055  
CNC 8055i

.TC- OPTION  
(SOFT: V16.1X)

### 3.8.4 Basic operation. Taper thread

The machining steps for this cycle are:

1. If the operation has been programmed with another tool, the CNC will change the tool and will move to the change position if so required by the machine.
2. The spindle starts at the selected speed and in the indicated direction. Depending on the spindle turning direction, the thread will be clockwise or counterclockwise.
3. The tool approaches in rapid to the theoretical corner keeping the selected safety distance in X and Z.

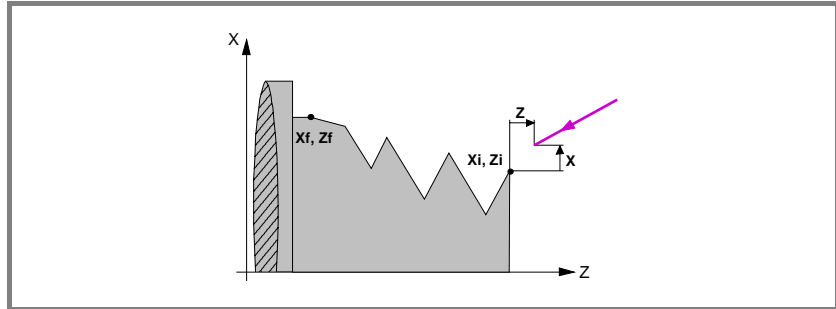

4. The threading is done in successive passes until the total depth is reached. The depth of each pass will depend on the selected model.
  - Depth depending on the pass number  $\Delta$ ,  $\Delta\sqrt{2}$ ,  $\Delta\sqrt{3}$ ,  $\Delta\sqrt{4}$ , etc.
  - Depth keeping the increment between passes  $\Delta$  constant.

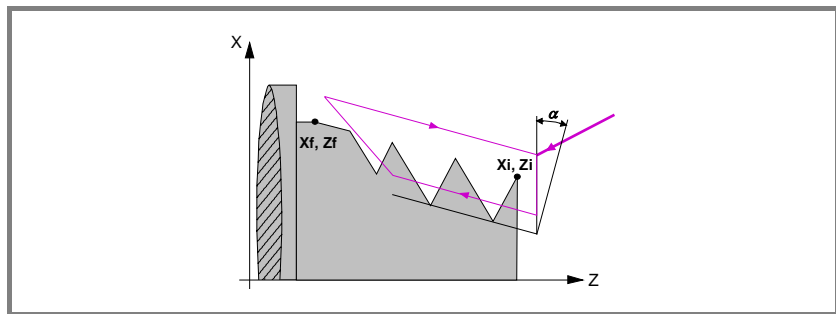

Each threading step is carried out as follows:

- Rapid move to the corresponding programmed depth. This move will be made according to the penetration angle ( $\alpha$ ) of the selected tool.
  - Threading of the programmed section, first along the defined profile up to the distance from the end of the thread ( $\sigma$ ) and then exit threading up to the final coordinate. The feedrate F cannot be varied with the feedrate override switch while threading; it will stay at 100%. At the beginning of the machining operation on large lathes, when cutting long threads, the spindle speed may be overridden in the first passes to prevent the part from bending.
  - Withdrawal in rapid to the approach point.
5. Once the operation or cycle has ended, the tool will return to the position it occupied when calling the cycle; i.e. to the point where [START] was pressed.  
When executing an entire part, combination of operations or cycles, the tool does not return to that point after executing each cycle.
  6. The CNC stops the spindle, but it keeps the machining conditions set; tool (T), feedrate of the axes (F) and spindle speed (S).

3.

WORKING WITH OPERATIONS OR CYCLES  
Threading cycle



CNC 8055  
CNC 8055i

-TC- OPTION  
(SOFT: V16.1X)



### 3.8.5 Basic operation. Face tapping

The machining steps for this cycle are:

1. If the operation has been programmed with another tool, the CNC will change the tool and will move to the change position if so required by the machine.
2. The spindle starts at the selected speed and in the indicated direction. Depending on the spindle turning direction, the thread will be clockwise or counterclockwise.
3. The tool approaches in rapid to the theoretical corner keeping the selected safety distance in X and Z.

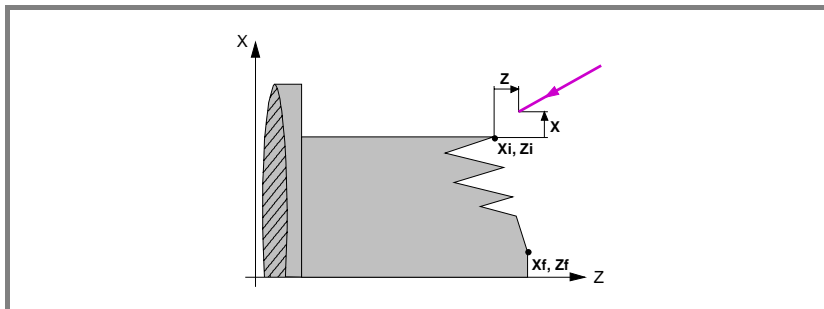

4. The threading is done in successive passes until the total depth is reached. The depth of each pass will depend on the selected model.
  - Depth depending on the pass number  $\Delta, \Delta\sqrt{2}, \Delta\sqrt{3}, \Delta\sqrt{4}$ , etc.
  - Depth keeping the increment between passes  $\Delta$  constant.

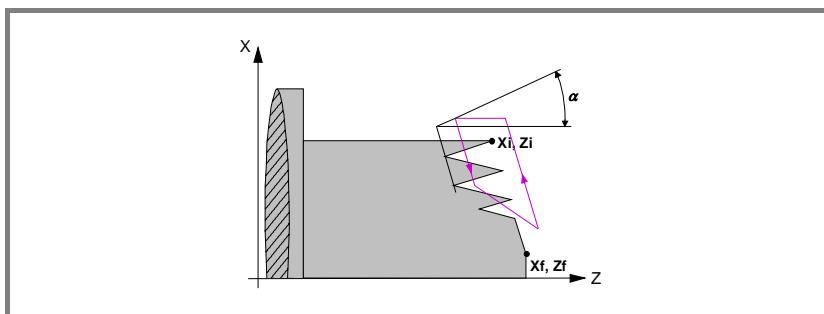

Each threading step is carried out as follows:

- Rapid move to the corresponding programmed depth. This move will be made according to the penetration angle ( $\alpha$ ) of the selected tool.
  - Threading of the programmed section, first along the defined profile up to the distance from the end of the thread ( $\sigma$ ) and then exit threading up to the final coordinate. The feedrate  $F$  cannot be varied with the feedrate override switch while threading; it will stay at 100%. At the beginning of the machining operation on large lathes, when cutting long threads, the spindle speed may be overridden in the first passes to prevent the part from bending.
  - Withdrawal in rapid to the approach point.
5. Once the operation or cycle has ended, the tool will return to the position it occupied when calling the cycle; i.e. to the point where [START] was pressed.  
When executing an entire part, combination of operations or cycles, the tool does not return to that point after executing each cycle.
  6. The CNC stops the spindle, but it keeps the machining conditions set; tool (T), feedrate of the axes (F) and spindle speed (S).

3.

WORKING WITH OPERATIONS OR CYCLES  
Threading cycle

FAGOR

CNC 8055  
CNC 8055i

.TC- OPTION  
(SOFT: V16.1X)

### 3.8.6 Basic operation. Thread repair

#### Cycle definition

Define the dimensions of the thread like in the rest of the level and the coordinates for one of the valleys (roots).



To define the coordinates of the root, the CNC must know the position of the spindle. The spindle must be oriented in order for the CNC to know the spindle position. On CNC power-up, it's enough to do this once.

Keeping the spindle stopped, move to thread repairing tool to one of the roots of the thread. Once there, take these 2 values:

- Z coordinate of the valley (root).  
Place the focus on the data and press [RECALL] [ENTER].
- Spindle angular position at the valley (root).  
Place the focus on the data and press [RECALL] [ENTER].

The CNC assumes these 2 data needed for thread repair.

#### Machining steps

The machining steps for this cycle are identical to those for taper threading described earlier. The CNC will make a new thread over the existing one, maintaining the roots and inclinations of the current thread.

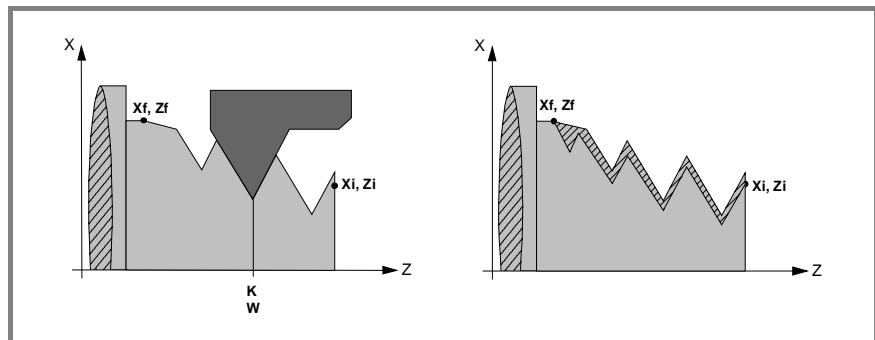

To do a thread repair, proceed as follows:

1. The spindle must have been oriented (M19) at least once since the CNC was turned on.
2. Take the values (teach-in) of the Z coordinate and the angular position of the spindle at the root, parameters K W, while the tool is positioned in one of the roots of the thread to be repaired.
3. Define the cycle for thread repair.
4. Execute the cycle.



CNC 8055  
CNC 8055i

.TC- OPTION  
(SOFT: V16.1X)

3. WORKING WITH OPERATIONS OR CYCLES Threading cycle

### 3.9 Grooving cycle



This key accesses the grooving cycles.

This cycle may be used to groove on the cylindrical side of the part or on its face, all of them with vertical walls or incline walls.

#### Level 1. Grooving on the cylindrical side.

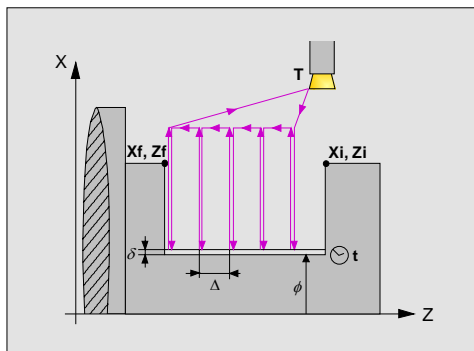

The following data must be defined:

- The coordinates of the first and last points.
- The final diameter.
- The dwell at the bottom.
- Number of grooves and offset.

#### Level 2. Face grooving.

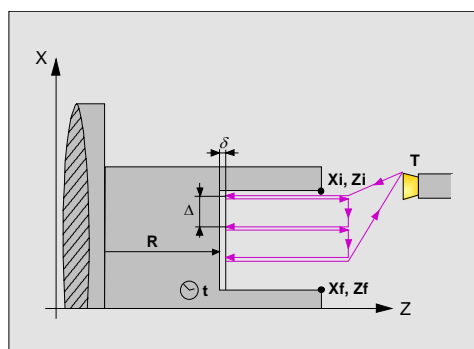

The following data must be defined:

- The coordinates of the first and last points.
- The coordinate of the bottom of the groove.
- The dwell at the bottom.
- Number of grooves and offset.

3.

WORKING WITH OPERATIONS OR CYCLES  
Grooving cycle



CNC 8055  
CNC 8055i

.TC- OPTION  
(SOFT: V16.1X)

# 3.

WORKING WITH OPERATIONS OR CYCLES  
Grooving cycle

### Level 3. Grooving on the side of the cylinder with incline walls.

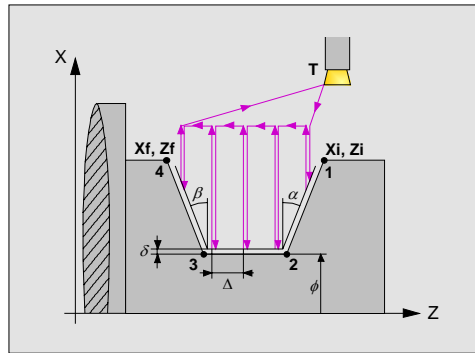

The following data must be defined:

- The coordinates of the first and last points.
- The final diameter.
- The Inclination angles of the incline walls.
- Number of grooves and offset.

### Level 4. Face grooving with incline walls.

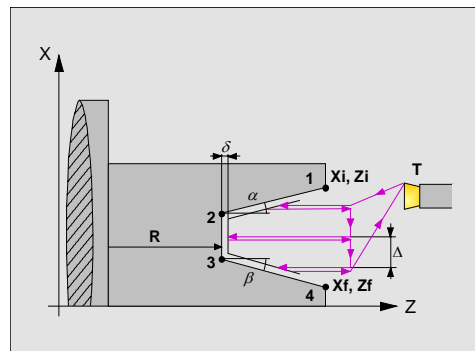

The following data must be defined:

- The coordinates of the first and last points.
- The coordinate of the bottom of the groove.
- The Inclination angles of the incline walls.
- Number of grooves and offset.

### Level 5. Cut-off.

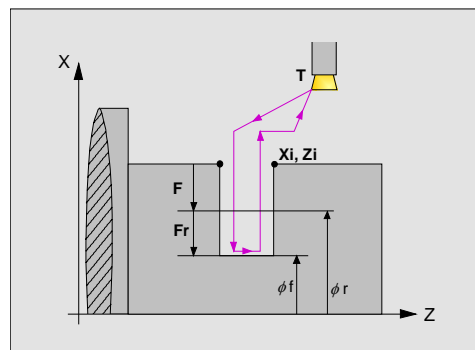

The following data must be defined:

- Coordinates of the starting point.
- The final diameter of the cut-off.
- The intermediate diameter to decrease the feedrate.
- The cut-off feedrate.



CNC 8055  
CNC 8055i

.TC- OPTION  
(SOFT: V16.1X)

### 3.9.1 Calibration of the grooving tool

When calibrating the grooving tool, you must properly indicate the location code for the corner that has been calibrated. Thus, the same tool may be calibrated in three different ways, as shown next:

- Location code F3. It calibrates the left corner of the cutter.

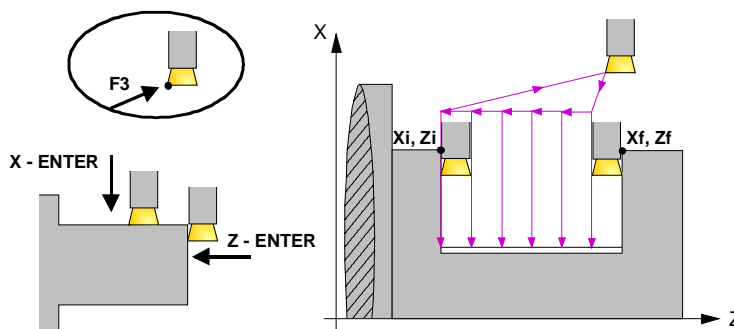

- Location code F1. It calibrates the right corner of the cutter.

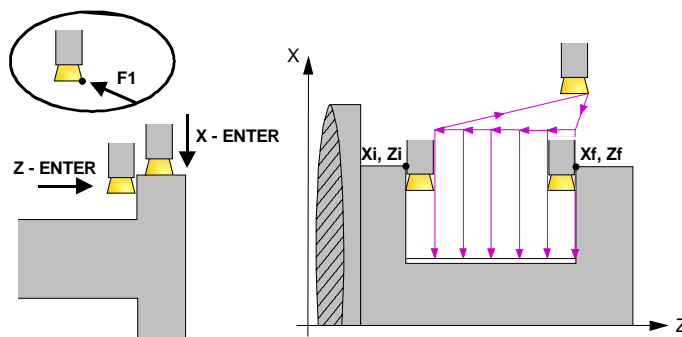

- Location code F2. The CNC only calibrates along the X axis and it assumes the center of the cutter as the calibrated point.

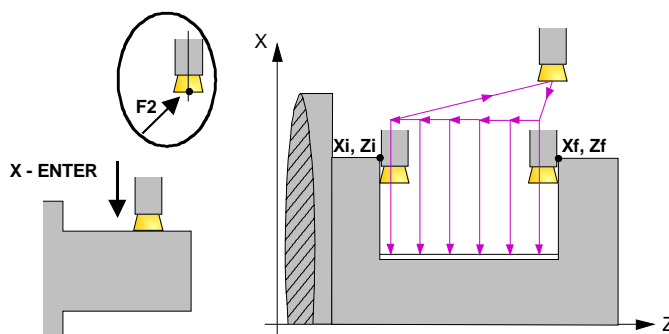

3.

WORKING WITH OPERATIONS OR CYCLES  
Grooving cycle

FAGOR

CNC 8055  
CNC 8055i

.TC- OPTION  
(SOFT: V16.1X)

### 3.9.2 Definition of geometry

#### Type of grooving.



To select the type of grooving, place the cursor over this icon and press the two-color key.



Inside grooving.



Outside grooving.

When changing the type of grooving, the CNC changes the icon and shows the corresponding help screen.

#### Coordinates of the first point ( $X_i, Z_i$ ) and of the last point ( $X_f, Z_f$ ).

The coordinates are defined one by one. After placing the cursor on the coordinates of the axes to be defined, the value is entered in one of the following ways.

- Entering the value manually. Key in the desired value and press [ENTER].
- Assign the current machine position.

Jog the axis with the handwheel or the JOG keys up to the desired point. Press [RECALL] so the selected data assumes the value shown in the top right window and press [ENTER].

The top right window shows the tool position at all times.

#### Intermediate diameter ( $\Phi_r$ ) and final diameter ( $\Phi_f$ ).

For the cut-off operation, you must define the final diameter and an intermediate diameter where start decreasing the feedrate (slowing down). To define these data, key in the desired value and press [ENTER].

#### Inclination angles ( $\alpha, \beta$ ).

These data must be defined when grooving with incline walls. To do this, place the cursor on the data, key in the desired value and press [ENTER].

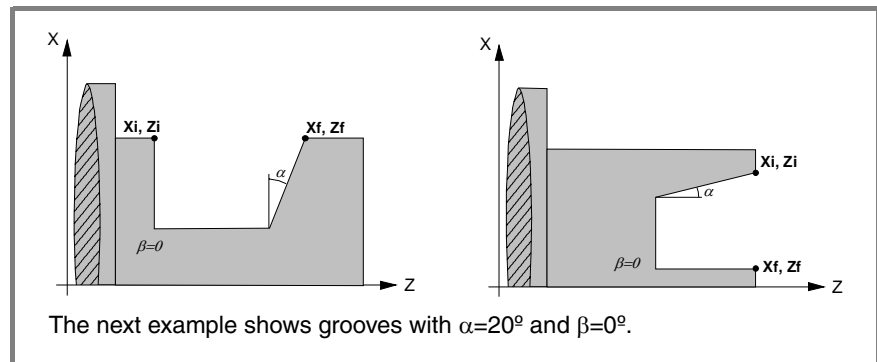
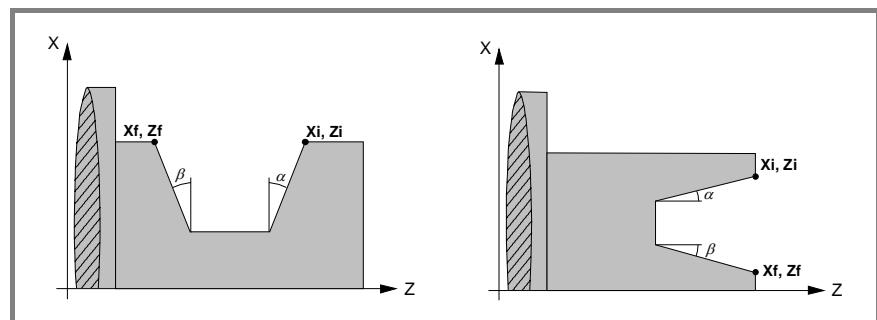

3. WORKING WITH OPERATIONS OR CYCLES Grooving cycle



CNC 8055  
CNC 8055i

-TC- OPTION  
(SOFT: V16.1X)

**Type of machining for each corner.**



To select the type of corner, place the cursor over this icon and press the two-color key.

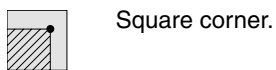

Square corner.

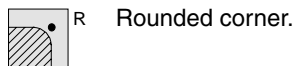

Rounded corner.

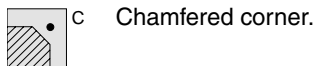

Chamfered corner.

These data must be defined when grooving with incline walls. The type of machining to perform must be defined in all four corners of the groove.

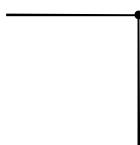

Square corner.

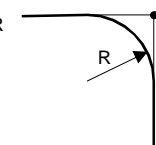

Rounded corner.

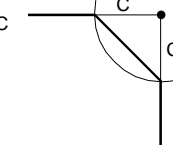

Chamfered corner.

For a rounded corner, define the rounding radius (R); for a chamfer, define the distance from the theoretical corner to the chamfer point (C). For cut-off, it is possible to also define the chamfer angle.

**Dwell at the bottom (t).**

Defines the dwell, in seconds, after each penetration until the withdrawal begins. To define it, place the cursor on this data, key in the desired value and press [ENTER].

**Safety distance.**

A part approach point may be set to prevent the tool from colliding with the part. The safety distance indicates the position of the approach point referred to the starting corner.

To change one of these values, place the cursor on the corresponding data, key in the desired value and press [ENTER].

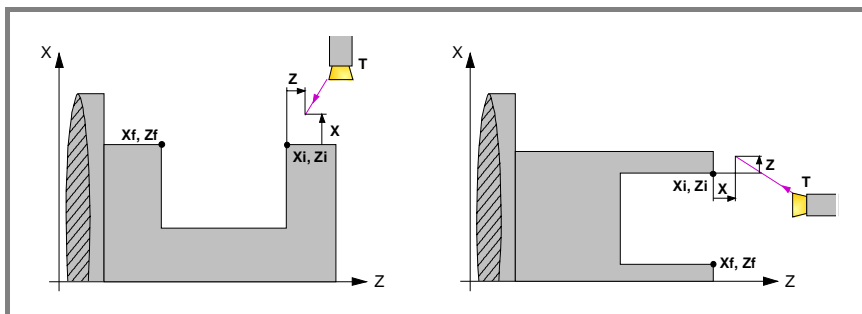

The safety distance in X is always defined in radius.

3.

WORKING WITH OPERATIONS OR CYCLES  
Grooving cycle



CNC 8055  
CNC 8055i

.TC- OPTION  
(SOFT: V16.1X)

# 3.

WORKING WITH OPERATIONS OR CYCLES  
Grooving cycle

### Type of machining for the roughing pass.



To select the type of grooving, place the cursor over this icon and press the two-color key.

Selection of the starting point of the grooving operation in the center of the groove:



The roughing process of the grooving starts at the center and goes on in the direction of the starting point. Once the starting point has been reached, it returns to the center and goes on in the direction of the final point until the end of the roughing operation.

Selection of the penetration step (pass) P and dwell t (in seconds) for chip removal in the first grooving pass:



Selection of the penetration step (pass) to keep the tool from overheating and dwell for chip removal after each pass.

This penetration in steps takes place during the first penetration and it is valid regardless of the selected starting point (center or corner).

### Type of machining for the finishing pass.



This data must be defined when grooving with incline walls. To select the type of machining, place the cursor over this icon and press the two-color key.

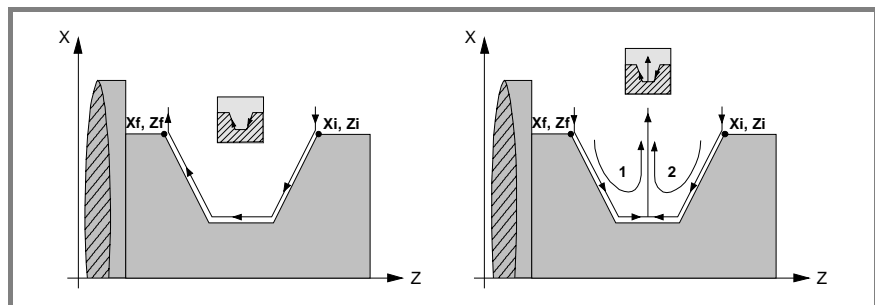

### Groove repetition.

The "number of grooves" and "offset" data may be used to repeat a groove several times along the Z axis in cylindrical grooving or along the X axis in face grooving.

If the first groove is tapered, Xi different from Xf, that taper is maintained for the rest of the grooves.

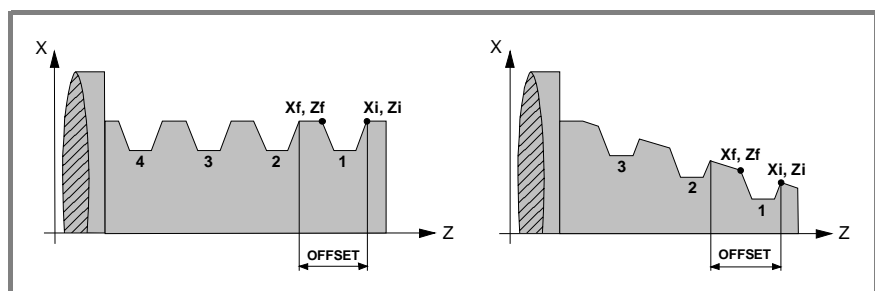

If the number of grooves is defined with a value of 0 or 1, it only makes one groove.

### Intermediate diameter ( $\Phi r$ ) and feedrate ( $Fr$ ).

For the cut-off operation, you must define an intermediate diameter where to start machining at low feedrate ( $Fr$ ) until the end of the cut-off operation. To define these data, key in the desired value and press [ENTER].



CNC 8055  
CNC 8055i

.TC- OPTION  
(SOFT: V16.1X)



### 3.9.3 Basic operation. Slot milling

The machining steps for this cycle are:

1. If the operation has been programmed with another tool, the CNC will change the tool and will move to the change position if so required by the machine.
2. The spindle starts at the selected speed and in the indicated direction.
3. The tool approaches in rapid to the starting point ( $X_i, Z_i$ ) keeping the selected safety distance in X and Z.

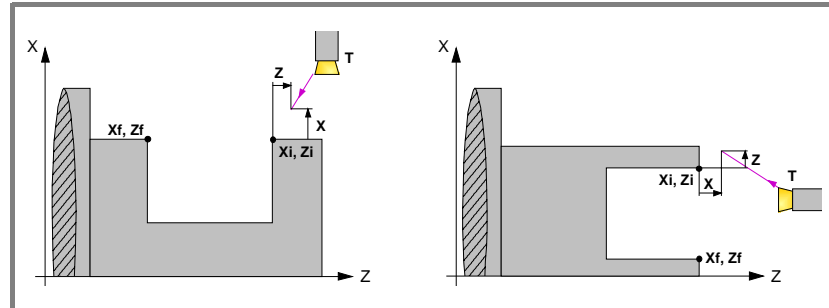

4. Roughing operation, with successive grooving passes, up to a distance from the final depth equal to the finishing stock.

This operation is carried out with the conditions set for the roughing operations; however, the CNC calculates the actual (real) pass so all the facing passes are identical. This pass will be equal to or smaller than the one defined  $\Delta$ .

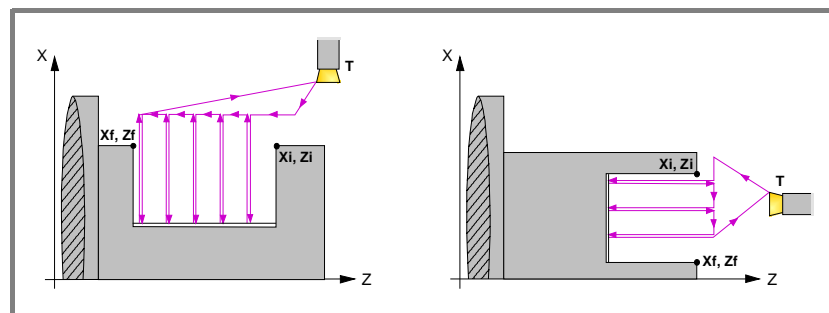

Each machining pass is done as shown in the figure, starting at point "1" and after going through points "2", "3" and "4", ending at point "5".

5. Finishing operation.

If the finishing operation has been programmed with another tool, the CNC will change the tool and will move to the change position if so required by the machine.

The finishing of the part is carried out with the machining conditions set for finishing; feedrate of the axes (F), spindle speed (S) and turning direction.

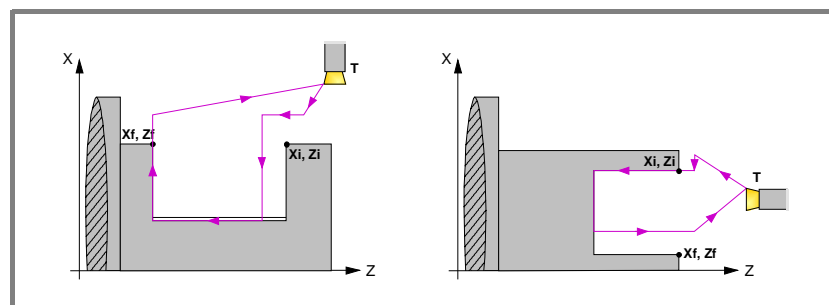

6. Once the operation or cycle has ended, the tool will return to the position it occupied when calling the cycle; i.e. to the point where [START] was pressed.

When executing an entire part, combination of operations or cycles, the tool does not return to that point after executing each cycle.

7. The CNC stops the spindle, but it keeps the machining conditions set; tool (T), feedrate of the axes (F) and spindle speed (S).

# 3.

WORKING WITH OPERATIONS OR CYCLES  
Grooving cycle



CNC 8055  
CNC 8055i

-TC- OPTION  
(SOFT: V16.1X)

## Considerations

### How to leave out the roughing or finishing operations.

By selecting T0 as the roughing tool, the cycle does not execute the roughing operation. In other words, after the approach movement, it will carry out the finishing operation.

By selecting T0 as the finishing tool, the cycle does not execute the finishing operation. In other words, after the roughing operation, the tool will move to the approach point maintaining the safety distance from the starting point ( $X_i, Z_i$ ).

### Different $X_i$ and $X_f$ coordinates.

When the surface to be machined is not totally cylindrical (different  $X_i$  and  $X_f$  coordinates), the CNC analyzes both coordinates and takes as the X coordinate of the starting point the one farthest away from the final depth.

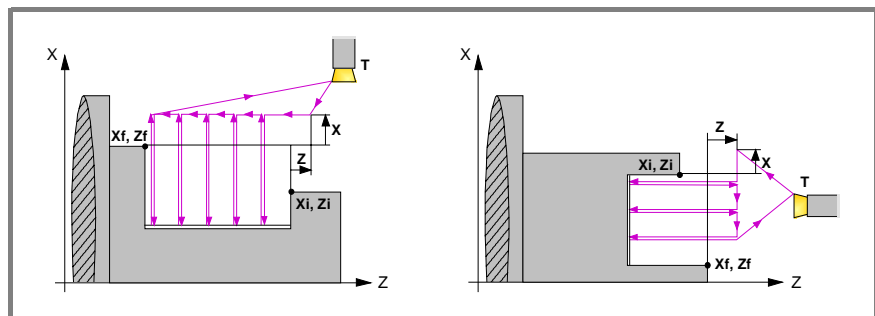

# 3.

WORKING WITH OPERATIONS OR CYCLES  
Grooving cycle



CNC 8055  
CNC 8055i

-TC- OPTION  
(SOFT: V16.1X)

### 3.9.4 Basic operation. Cut-off

The machining steps for this cycle are:

1. If the operation has been programmed with another tool, the CNC will change the tool and will move to the change position if so required by the machine.
2. The spindle starts at the selected speed and in the indicated direction.
3. The tool approaches in rapid to the starting point (Xi, Zi) keeping the selected safety distance in X and Z.
4. Cut-off operation, at feedrate F, up to the intermediate diameter. From this point on, the cut-off operation continues at feedrate F up to the final diameter.
5. Once the operation or cycle has ended, the tool will return to the position it occupied when calling the cycle; i.e. to the point where [START] was pressed.  
When executing an entire part, combination of operations or cycles, the tool does not return to that point after executing each cycle.
6. The CNC stops the spindle, but it keeps the machining conditions set; tool (T), feedrate of the axes (Fr) and spindle speed (S).

**3.**

**WORKING WITH OPERATIONS OR CYCLES**  
Grooving cycle



**CNC 8055  
CNC 8055i**

.TC· OPTION  
(SOFT: V16.1X)

### 3.10 Drilling and tapping cycles



This key accesses the drilling and tapping cycles.

There may be up to 5 cycles available depending on the type of machine and how the CNC machine parameters have been set:

- Drilling cycle.
- Multiple drilling cycle.
- Tapping cycle.
- Multiple threading cycle.
- Multiple slot milling cycle.

The drilling and tapping cycles are always available. The multiple drilling, multiple threading and multiple slot milling cycles are available when the machine has a live tool and spindle orientation.

#### Level 1. Drilling cycle.

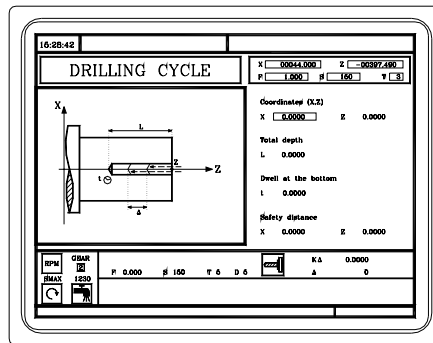

The following data must be defined:

- Coordinates of the drilling point.
- The total depth.
- The dwell at the bottom.

#### Level 2. Tapping cycle.

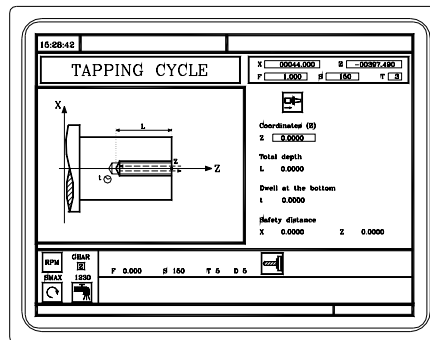

The following data must be defined:

- Z coordinate of the tapping point.
- The total depth.
- The dwell at the bottom.

**3.**  
WORKING WITH OPERATIONS OR CYCLES  
Drilling and tapping cycles



CNC 8055  
CNC 8055i

.TC- OPTION  
(SOFT: V16.1X)

### Level 3. Multiple drilling cycle.

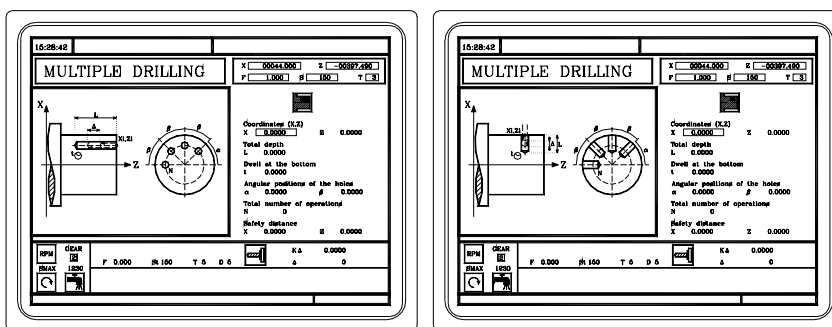

Multiple drilling can be done on the cylindrical side of the part or on its face. The following data must be defined:

- The coordinates of the starting point.
- The total depth.
- The dwell at the bottom.
- The angular position of the holes.
- The total number of holes.

### Level 4. Multiple threading cycle.

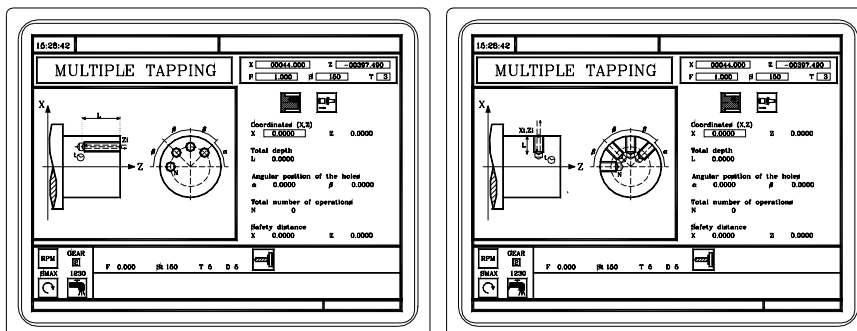

Multiple threading can be done on the cylindrical side of the part or on its face. The following data must be defined:

- The coordinates of the starting point.
- The total depth.
- The angular position of the threads.
- The total number of threads.

### Level 5. Multiple slot milling cycle.

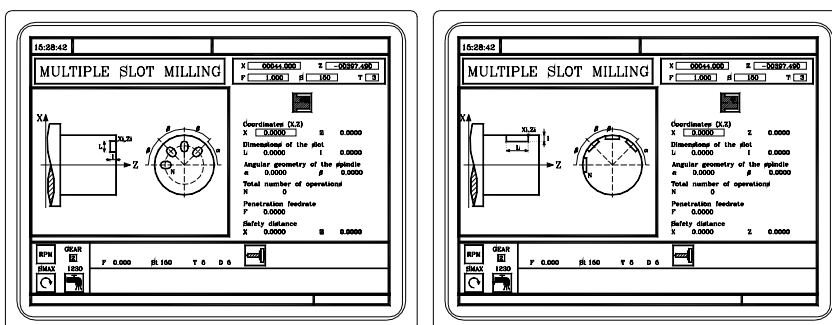

Multiple slot milling can be done on the cylindrical side of the part or on its face. The following data must be defined:

- The coordinates of the starting point.
- The dimensions of the slot.
- The angular position of the slots.
- The total number of slots.

# 3.

WORKING WITH OPERATIONS OR CYCLES  
Drilling and tapping cycles



CNC 8055  
CNC 8055i

-TC- OPTION  
(SOFT: V16.1x)

### 3.10.1 Geometry definition



**Machining on the face of the part or on its side.**

To select the type of machining, place the cursor over this icon and press the two-color key.



Machining on the face of the part.



Machining on the cylindrical side of the part.

When changing the type of machining, the CNC changes the icon and shows the corresponding help screen.

**Coordinates of the starting point (X, Z).**

The coordinates are defined one by one. After placing the cursor on the coordinates of the axes to be defined, the value is entered in one of the following ways.

- Entering the value manually. Key in the desired value and press [ENTER].
- Assign the current machine position.

Jog the axis with the handwheel or the JOG keys up to the desired point. Press [RECALL] so the selected data assumes the value shown in the top right window and press [ENTER].

The top right window shows the tool position at all times.

Tapping must always be axial, at the rotation center (X0). For drilling, although usually done at the rotation center, it is possible to define X with a value other than X0.

**Total depth (L).**

Place the cursor on this data, key in the desired value and press [ENTER].

**Withdrawal distance (H) and approach distance (C).**

Parameter H defines the distance for the tool to withdraw after each drilling peck. Parameter C defines the distance from the previous drilling peck where the tool approaches in rapid. To define these parameters, key in the desired value and press [ENTER].

**Dwell at the bottom (t).**

Defines the dwell, in seconds, after the drilling or threading until the withdrawal begins. To define it, place the cursor on this data, key in the desired value and press [ENTER].

**Angular position of the machining operations ( $\alpha$ ,  $\beta$ ).**

The  $\alpha$  data indicates the angular position of the first machining operation and the  $\beta$  data the angular step between machining operations. To define them, place the cursor on the corresponding data, key in the desired value and press [ENTER].

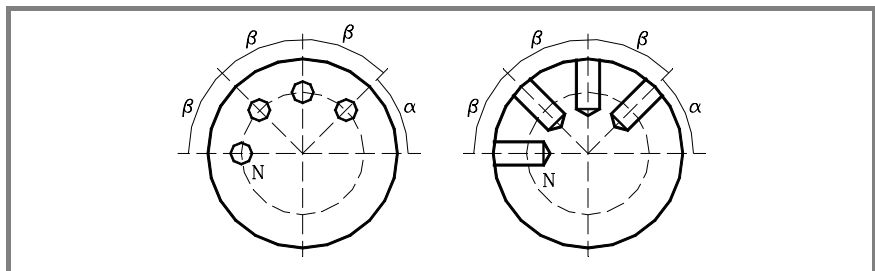

**Number of operations (N).**

Place the cursor on this data, key in the desired value and press [ENTER].

**3.**

WORKING WITH OPERATIONS OR CYCLES  
Drilling and tapping cycles



CNC 8055  
CNC 8055i

.TC- OPTION  
(SOFT: V16.1X)

**Dimensions of the slot (L, I).**

"L" indicates the length of the slot and "I" its depth. To define them, place the cursor on the corresponding data, key in the desired value and press [ENTER].

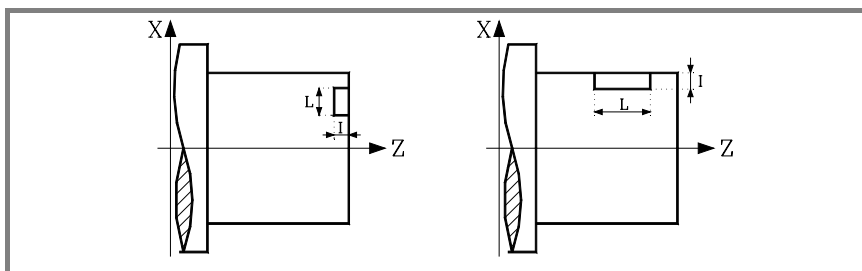

**Penetrating feedrate (F).**

Place the cursor on this data, key in the desired value and press [ENTER].

**Safety distance.**

A part approach point may be set to prevent the tool from colliding with the part. The safety distance indicates the position of the approach point referred to the drilling or threading point.

To change one of these values, place the cursor on the corresponding data, key in the desired value and press [ENTER].

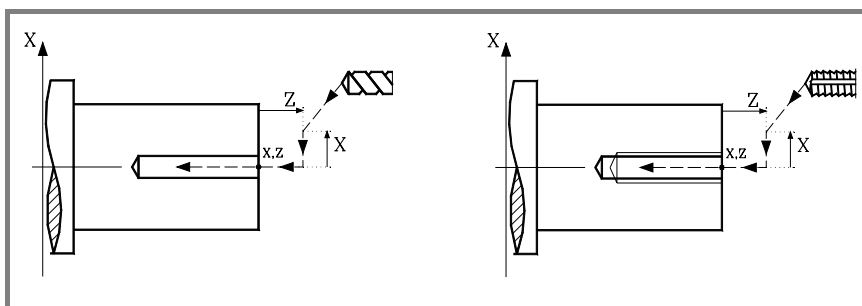

The safety distance in X is always defined in radius.

3.

WORKING WITH OPERATIONS OR CYCLES  
Drilling and tapping cycles



CNC 8055  
CNC 8055i

.TC- OPTION  
(SOFT: V16.1X)

### 3.10.2 Drilling cycle. Basic operation

The machining steps for this cycle are:

1. If the operation has been programmed with another tool, the CNC will change the tool and will move to the change position if so required by the machine.
2. The spindle starts at the selected speed and in the indicated direction.
3. The tool approaches in rapid to the starting point ( $X_i, Z_i$ ) keeping the selected safety distance in X and Z.

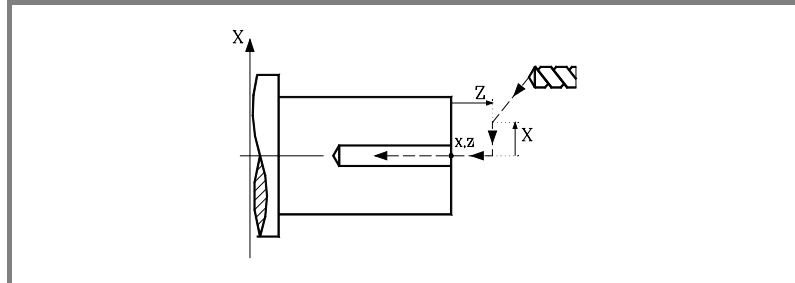

4. Drilling loop. The following steps are repeated, penetrating each time the amount indicated by  $K\Delta$  and  $\Delta$  until reaching the L depth.  $\Delta$  defines the drilling peck and  $K\Delta$  the reduction factor of that peck.
  - The first drilling peck will be  $\Delta$ , the second one " $K\Delta \Delta$ ", The third one " $K\Delta (K\Delta \Delta)$ " and so on; in other words, from the second peck on, the new peck will be the product of the  $K\Delta$  factor times the previous peck.
  - After each drilling peck, the tool withdraws a distance "H". Then, it approaches in rapid up to a "C" distance from the previous penetration; if "C" has not been defined, the tool approaches up to 1 mm from the previous penetration.
  - Drilling down to the next penetration.
  - Withdrawal in rapid to the approach point.
5. Dwell "t" at the bottom of the hole.
6. Withdrawal in rapid to the approach point.
7. Once the operation or cycle has ended, the tool will return to the position it occupied when calling the cycle; i.e. to the point where [START] was pressed.  
When executing an entire part, combination of operations or cycles, the tool does not return to that point after executing each cycle.
8. The CNC stops the spindle, but it keeps the machining conditions set; tool (T), feedrate of the axes (F) and spindle speed (S).

3.  
**WORKING WITH OPERATIONS OR CYCLES**  
 Drilling and tapping cycles



CNC 8055  
CNC 8055i

-TC- OPTION  
(SOFT: V16.1X)



### 3.10.3 Tapping cycle. Basic operation

The machining steps for this cycle are:

1. If the operation has been programmed with another tool, the CNC will change the tool and will move to the change position if so required by the machine.
2. The spindle starts at the selected speed and in the indicated direction.
3. The tool approaches in rapid to the starting point (Xi, Zi) keeping the selected safety distance in X and Z.

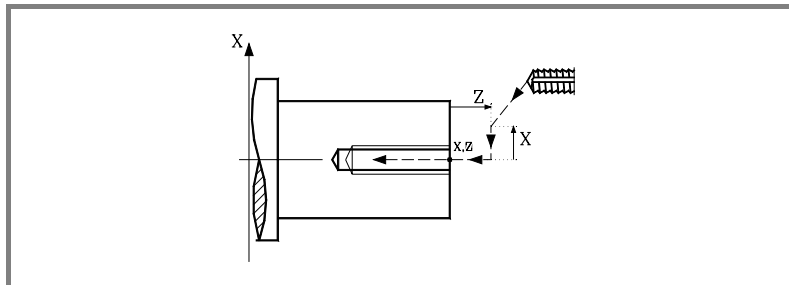

4. Threading of the part at work feedrate F up to the "L" depth.



Tapping (with a clutch).



Rigid tapping. The spindle must have a motor-drive-encoder system.

5. Reverse the spindle turning direction.

If a dwell has been defined for the bottom of the hole, the spindle stops and after the programmed dwell has elapsed, the spindle starts turning in the other way.

6. Withdrawal in work feedrate to the approach point.
7. Once the operation or cycle has ended, the tool will return to the position it occupied when calling the cycle; i.e. to the point where [START] was pressed.

When executing an entire part, combination of operations or cycles, the tool does not return to that point after executing each cycle.

8. The CNC stops the spindle, but it keeps the machining conditions set; tool (T), feedrate of the axes (F) and spindle speed (S).

General logic output "TAPPING" (M5517) stays active while executing the cycle.

3.

WORKING WITH OPERATIONS OR CYCLES  
Drilling and tapping cycles

**FAGOR** 

CNC 8055  
CNC 8055i

.TC- OPTION  
(SOFT: V16.1x)

### 3.10.4 Multiple drilling cycle. Basic operation

The machining steps for this cycle are:

1. If the spindle was working in open loop (RPM or CSS mode) the CNC stops the spindle and homes the spindle.
2. If the operation has been programmed with another tool, the CNC will change the tool and will move to the change position if so required by the machine.
3. The CNC starts the live tool at the selected speed and in the indicated direction.
4. Orients the spindle at the angular position for the first hole (indicated by  $\alpha$ ).

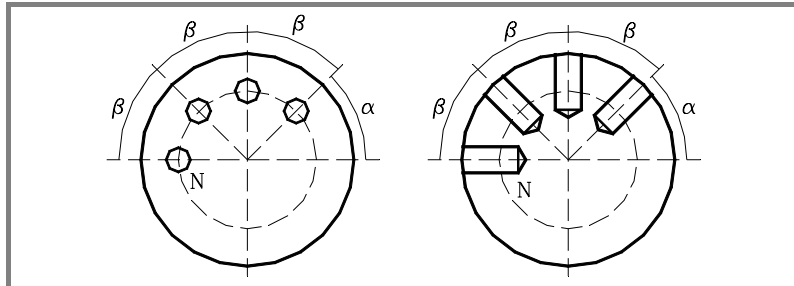

5. The tool approaches in rapid to the starting point keeping the selected safety distance in X and Z.

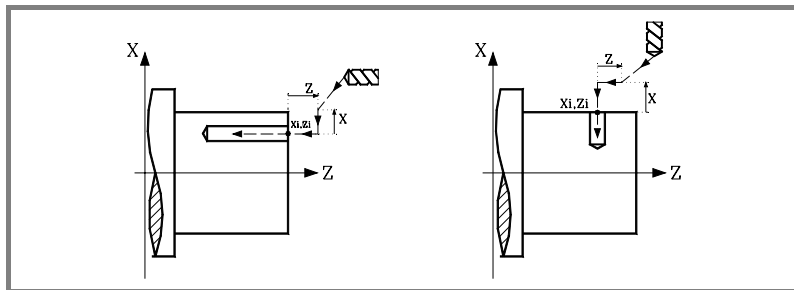

6. Drilling loop. The following steps are repeated, penetrating each time the amount indicated by  $K\Delta$  and  $\Delta$  until reaching the L depth.  $\Delta$  defines the drilling peck and  $K\Delta$  the reduction factor of that peck.
  - The first drilling peck will be  $\Delta$ , the second one " $K\Delta$ ", The third one " $K\Delta (K\Delta \Delta)$ " and so on; in other words, from the second peck on, the new peck will be the product of the  $K\Delta$  factor times the previous peck.
  - After each drilling peck, the tool withdraws a distance "H". Then, it approaches in rapid up to a "C" distance from the previous penetration; if "C" has not been defined, the tool approaches up to 1 mm from the previous penetration.
  - Drilling down to the next penetration.
  - Withdrawal in rapid to the approach point.
7. Dwell "t" at the bottom of the hole.
8. Withdrawal in rapid to the approach point.
9. Depending on the value assigned to parameter N (number of holes), the CNC repeats the following steps N times.
  - The spindle moves to the next drilling point (angular increment  $\beta$ ).
  - Repeats the drilling movements indicated in steps 6, 7 and 8.
10. Once the operation or cycle has ended, the tool will return to the position it occupied when calling the cycle; i.e. to the point where [START] was pressed.
 

When executing an entire part, combination of operations or cycles, the tool does not return to that point after executing each cycle.
11. The CNC stops the spindle, but it keeps the machining conditions set; tool (T), feedrate of the axes (F) and spindle speed (S).

# 3.

WORKING WITH OPERATIONS OR CYCLES  
Drilling and tapping cycles



CNC 8055  
CNC 8055i

-TC- OPTION  
(SOFT: V16.1X)

### 3.10.5 Multiple threading cycle. Basic operation

The machining steps for this cycle are:

1. If the spindle was working in open loop (RPM or CSS mode) the CNC stops the spindle and homes the spindle.
2. If the operation has been programmed with another tool, the CNC will change the tool and will move to the change position if so required by the machine.
3. The CNC starts the live tool at the selected speed and in the indicated direction.
4. Orients the spindle at the angular position for the first hole (indicated by  $\alpha$ ).

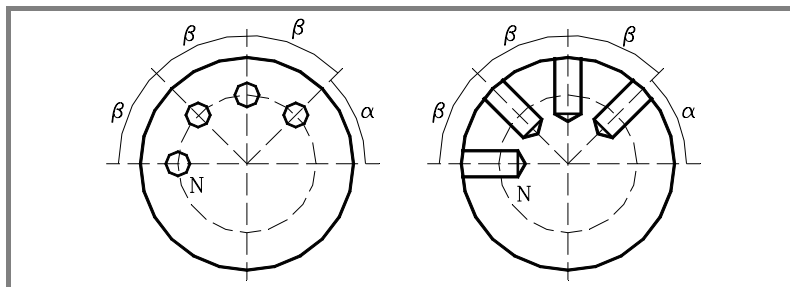

5. The tool approaches in rapid to the starting point keeping the selected safety distance in X and Z.

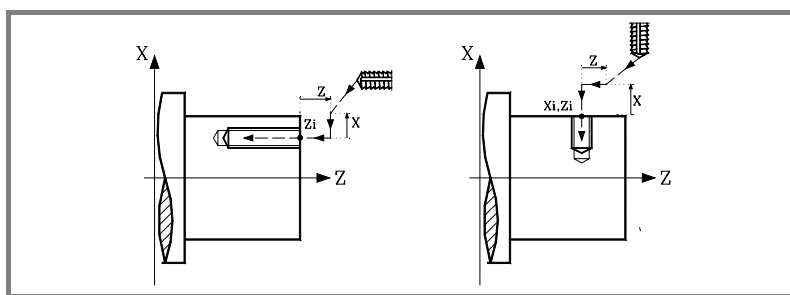

6. Threading of the part at work feedrate F up to the "L" depth.



Tapping (with a clutch).



Rigid tapping. The spindle must have a motor-drive-encoder system.

7. Reversal of the turning direction of the live tool.
8. Withdrawal in work feedrate to the approach point.
9. Depending on the value assigned to parameter N (number of holes), the CNC repeats the following steps N times.
  - The spindle moves to the next drilling point (angular increment  $\beta$ ).
  - Repeats the drilling movements indicated in steps 6, 7 and 8.
10. Once the operation or cycle has ended, the tool will return to the position it occupied when calling the cycle; i.e. to the point where [START] was pressed.
 

When executing an entire part, combination of operations or cycles, the tool does not return to that point after executing each cycle.
11. The CNC stops the spindle, but it keeps the machining conditions set; tool (T), feedrate of the axes (F) and spindle speed (S).

General logic output "TAPPING" (M5517) stays active while executing the cycle.

3.

WORKING WITH OPERATIONS OR CYCLES  
Drilling and tapping cycles



CNC 8055  
CNC 8055i

.TC- OPTION  
(SOFT: V16.1x)

### 3.10.6 Multiple slot milling cycle. Basic operation

The machining steps for this cycle are:

1. If the spindle was working in open loop (RPM or CSS mode) the CNC stops the spindle and homes the spindle.
2. If the operation has been programmed with another tool, the CNC will change the tool and will move to the change position if so required by the machine.
3. The CNC starts the live tool at the selected speed and in the indicated direction.
4. Orients the spindle at the angular position for the first hole (indicated by  $\alpha$ ).

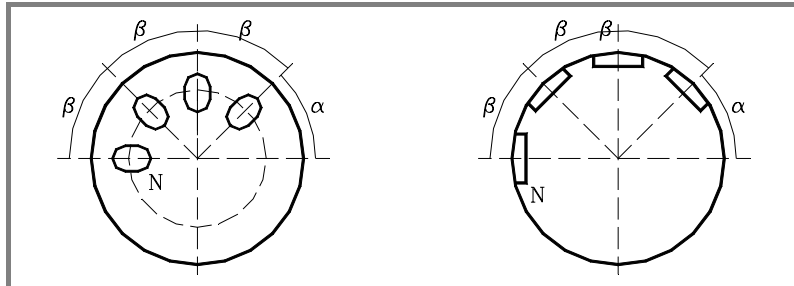

5. The tool approaches in rapid to the starting point keeping the selected safety distance in X and Z.

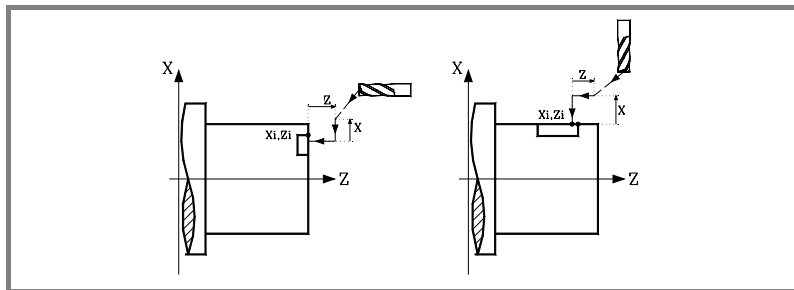

6. Milling of the slot by following these steps:

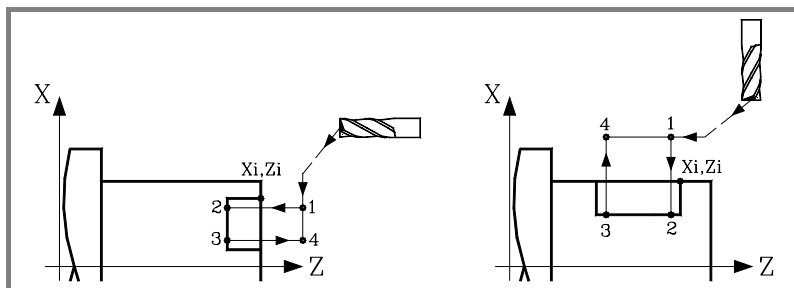

- Penetration at programmed feedrate  $F$  to the bottom of the slot (section 1-2).
  - It mills the slot by moving the X or Z axis (accordingly) at the programmed " $F$ " feedrate (section 2-3).
  - Withdrawal to the approach point (sections 3-4 and 4-1).
7. Depending on the value assigned to parameter  $N$  (number of holes), the CNC repeats the following steps  $N$  times.
    - The spindle moves to the next drilling point (angular increment  $\beta$ ).
    - Repeats the drilling movements indicated at the step 6.
  8. Once the operation or cycle has ended, the tool will return to the position it occupied when calling the cycle; i.e. to the point where [START] was pressed.  
When executing an entire part, combination of operations or cycles, the tool does not return to that point after executing each cycle.
  9. The CNC stops the spindle, but it keeps the machining conditions set; tool (T), feedrate of the axes (F) and spindle speed (S).

# 3.

WORKING WITH OPERATIONS OR CYCLES  
Drilling and tapping cycles



CNC 8055  
CNC 8055i

-TC- OPTION  
(SOFT: V16.1X)

### 3.11 Profiling cycle



This key accesses the profiling cycles.

This cycle may be defined in several ways.

#### Level 1. Defining all the points of the profile.

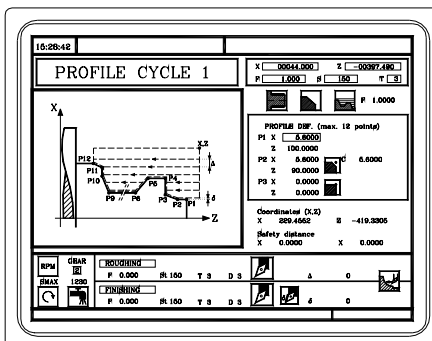

#### Level 2. Using a part-program that contains a profile.

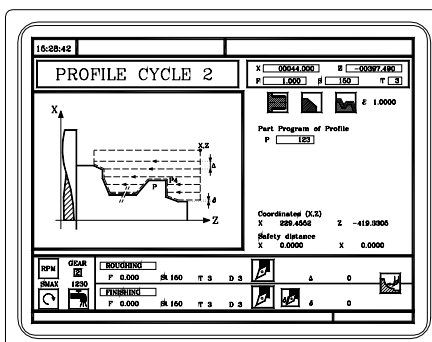

#### Level 3. ZC profile. Available when having a "C" axis.

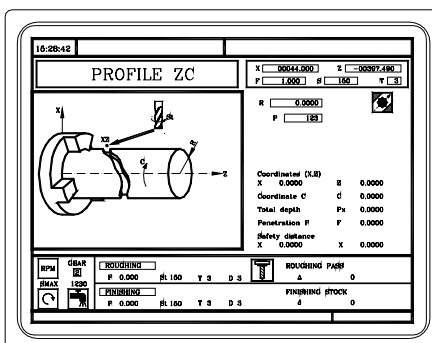

#### Level 4. XC profile. Available when having a "C" axis.

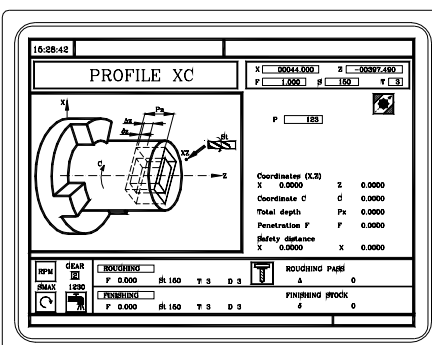

3.

WORKING WITH OPERATIONS OR CYCLES  
Profiling cycle



CNC 8055  
CNC 8055i

-TC- OPTION  
(SOFT: V16.1x)

### 3.11.1 Level 1. Profile definition

This mode may be used to define the profile by describing its theoretical corners. Up to 12 points may be used in the cycle to define those corners. Point P1 is the starting point of the profile. The rest of the points must be sequential.

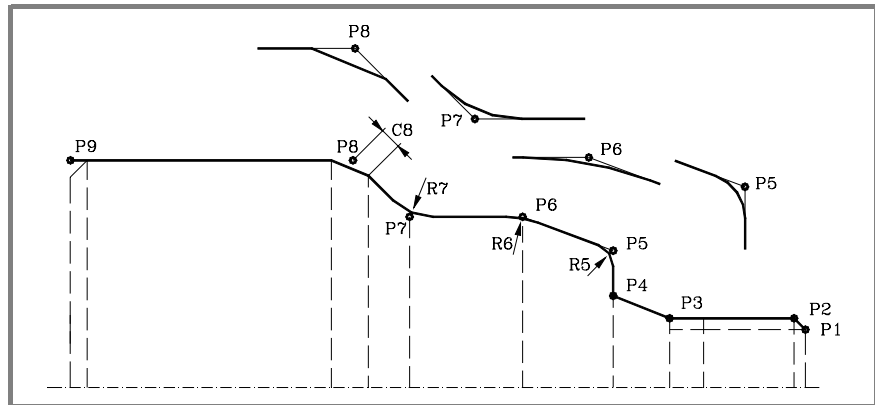

Use the [↓] [↑] keys to select and exit the window that contains the profile defining points and the [←] [→] keys to define those points.

#### Coordinates of the first and last points.

The coordinates of each point are defined one by one. After placing the cursor on the coordinate to be defined, the value is entered in one of the following ways.

- Entering the value manually. Key in the desired value and press [ENTER].
- Assign the current machine position.

Jog the axis with the handwheel or the JOG keys up to the desired point. Press [RECALL] so the selected data assumes the value shown in the top right window and press [ENTER].

The top right window shows the tool position at all times.

#### Intermediate points.

The intermediate points are defined one by one. If a coordinate is left blank, the cycle will assume that it is the same as that of the previous one. When not using all 12 definition points, the following conditions must be met:

- The CNC ignores the machining type of the last point of the profile.
- The first unused point must be defined with the same coordinates as the last point of the profile. P10 must be set equal to P9 in the example of the figure above.

If defined...	The CNC assumes...
X1 25.323    Z1 26.557	Point: X1 25.323    Z1 26.557
X2            Z2 78.998	Point: X2 25.323    Z2 78.998
X3 67.441    Z3 83.231	Point: X3 67.441    Z3 83.231
X4            Z4	Point: X4 67.441    Z4 83.231
X5            Z5	There are no more points, it is a repetition of the previous point.

The coordinates of each point may also be defined incrementally. To do that, select the desired coordinate with the cursor and press the two-color key. Both coordinates of the selected point will be shown preceded by the "Δ" icon that indicates the incremental value with respect to the previous point.



The type of machining to perform at the corner must be defined in all the intermediate points of the profile. To select the type of corner, place the cursor over this icon and press the two-color key.

# 3.

WORKING WITH OPERATIONS OR CYCLES  
Profiling cycle



CNC 8055  
CNC 8055i

.TC- OPTION  
(SOFT: V16.1X)

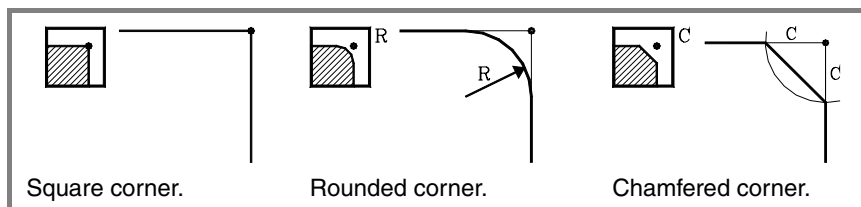

For a rounded corner, define the rounding radius (R); for a chamfer, define the distance from the theoretical corner to the chamfer point (C).

**Deleting all the points of a profile.**

Once all the desired points have been programmed, they may all be erased at once. To delete all the programmed points at the same time, proceed as follows:

- Place the cursor on the text "DEF. PROFILE (max 12 points)" of the window where the points are edited.
- In the instant the cursor is placed in this position, the text changes to: "CLEAR - Delete all the points".
- At this moment, pressing [CLEAR] displays a window requesting confirmation to delete all the points: Press the [ENTER] to delete all the points or [ESC] not to delete them.

**3.**

**WORKING WITH OPERATIONS OR CYCLES**  
Profiling cycle



CNC 8055  
CNC 8055i

.TC- OPTION  
(SOFT: V16.1X)

### 3.11.2 Levels 2, 3 and 4. Profile definition

# 3.

WORKING WITH OPERATIONS OR CYCLES

Profiling cycle

#### ***Defining the profile program.***

The profile program may be defined as follows.

- Key in the profile program number directly.  
If the "profile program" is known, key in the program number and press [ENTER].
- Access the "profile programs" to select one of them.  
Press the [↓] key. The canned cycle will show a window with the profile programs currently defined. Use the [↑] and [↓] keys to move around this window. After positioning the cursor on the desired program, press [ENTER].  
To exit this window without selecting any program, use the [←] y [→] keys.

#### ***Editing a new profile program.***

To edit a new profile program, key in the program number (between 0 and 999) and press [RECALL]. The CNC will show the window for the profile editor (see operation manual).

Once the profile has been edited, the CNC requests the comment to be associated with the profile program being edited. Enter the desired comment and press [ENTER]. If no comment is desired, press [ESC].

#### ***Copying a profile program.***

Press the [↓] key. The canned cycle will show the profile programs currently defined. Place the cursor on the profile program to be copied and press [P.PROG]. The CNC requests the number of the new profile and it allows changing its comment. If the number entered is the same as that of an existing profile, the CNC requests confirmation to replace it.

#### ***Modifying an existing profile program.***

To modify a profile program, key in the program number and press [RECALL]. The CNC will show, in the window for the profile editor, the profile that is currently defined.

With this profile, the following actions are possible:

- Adding new elements at the end of the current profile.
- Modifying the data of any element.
- Modifying or including chamfers, rounding, etc.
- Deleting elements of the profile.

#### ***Deleting an existing profile program.***

Press the [↓] key. The canned cycle will show the profile programs currently defined. Place the cursor on the profile program to be deleted and press [CLEAR]. The CNC requests confirmation.



CNC 8055  
CNC 8055i

-TC- OPTION  
(SOFT: V16.1X)



## Notes

---

The profile programs can also be accessed in the "T" mode because the CNC saves them internally as:

P998xxx (ZX profile, level 2).

Profile program 11 is saved as P998011.

P997xxx (ZC profile, level 3).

Profile program 22 is saved as P997022.

P996xxx (XC profile, level 4).

Profile program 33 is saved as P996033.

When saving a part-program that contains a profile cycle into an external device, also save its associated profile cycle (P998xxx, P997xxx, P996xxx).

**3.**

**WORKING WITH OPERATIONS OR CYCLES**  
Profiling cycle

**FAGOR** 

**CNC 8055  
CNC 8055i**

.TC- OPTION  
(SOFT: V16.1X)

### 3.11.3 Level 2. Optimizing the machining of a profile

If only the desired profile is defined, the CNC assumes that the original stock is cylindrical and machines it as shown on the left.

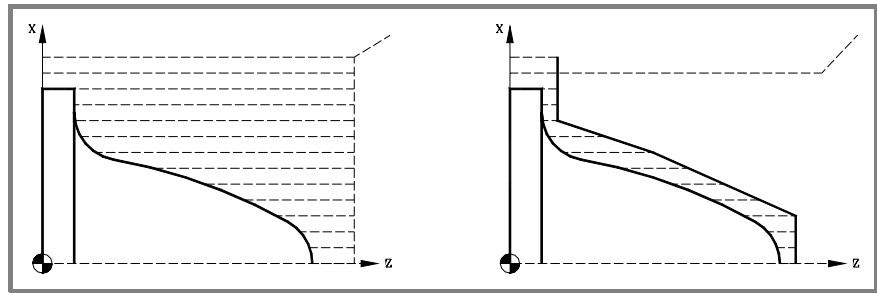

When the stock profile is known, it is recommended to define both profiles: The profile of the original stock and the desired final profile. The machining operation is much faster because only the stock delimited by both profiles is removed.

Follow this order to define both profiles:

1. Access the profile editor.
2. Edit the desired final profile.
3. Press the softkey for a new profile.
4. Edit the profile of the original stock.
5. Quit the profile editor saving the profile.

Remember that the desired final profile must be defined first and then the profile of the original stock.

## 3.

WORKING WITH OPERATIONS OR CYCLES  
Profiling cycle



CNC 8055  
CNC 8055i

.TC- OPTION  
(SOFT: V16.1X)

### 3.11.4 Definition of geometry levels 1 and 2. ZX profile

#### Outside or inside profile.



To select the type of profile, place the cursor over this icon and press the two-color key.



Inside profile.



Outside profile.

When changing the type of profile, the CNC changes the icon and shows the corresponding help screen.

#### Work quadrant.



The work quadrant is defined with the following icons: To select the desired type, place the cursor over this icon and press the two-color key.

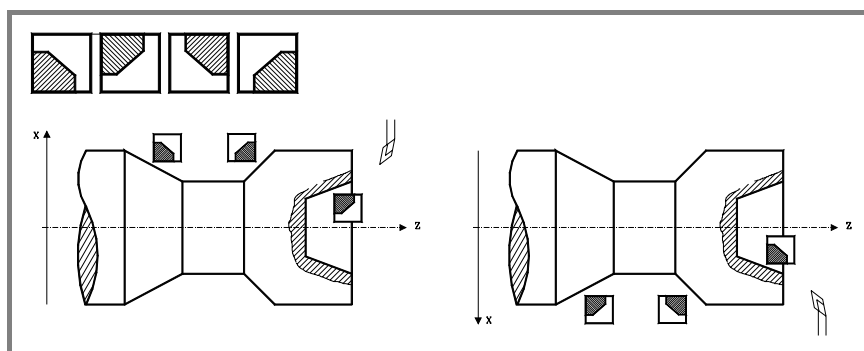

#### Tool of machining.



The type of machining is defined with the following icons: To select the desired type, place the cursor over this icon and press the two-color key.



F 1.0000 Paraxial machining (one axis at a time).



$\epsilon$  1.0000 Machining following the profile

When changing the type of machining, the CNC changes the icon and shows the corresponding help screen.

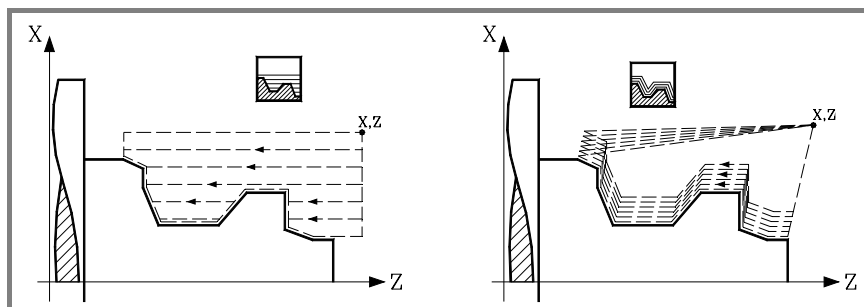

In paraxial machining you must define the feedrate (F) for the tool to penetrate into the valleys. The machining feedrate will be the one indicated in the roughing and finishing windows.

In pattern repeat, the amount of stock to be removed from the original stock ( $\epsilon$ ) must be defined. That value is defined in radius.

3.

WORKING WITH OPERATIONS OR CYCLES  
Profiling cycle



CNC 8055  
CNC 8055i

.TC- OPTION  
(SOFT: V16.1X)

# 3.

WORKING WITH OPERATIONS OR CYCLES  
Profiling cycle

### Coordinates of the starting point (X, Z).

The coordinates are defined one by one. After placing the cursor on the coordinates of the axes to be defined, the value is entered in one of the following ways.

- Entering the value manually. Key in the desired value and press [ENTER].
- Assign the current machine position.

Jog the axis with the handwheel or the JOG keys up to the desired point. Press [RECALL] so the selected data assumes the value shown in the top right window and press [ENTER].

The top right window shows the tool position at all times.

### Safety distance.

A part approach point may be set to prevent the tool from colliding with the part. The safety distance indicates the position of the approach point referred to the starting corner.

To change one of these values, place the cursor on the corresponding data, key in the desired value and press [ENTER].

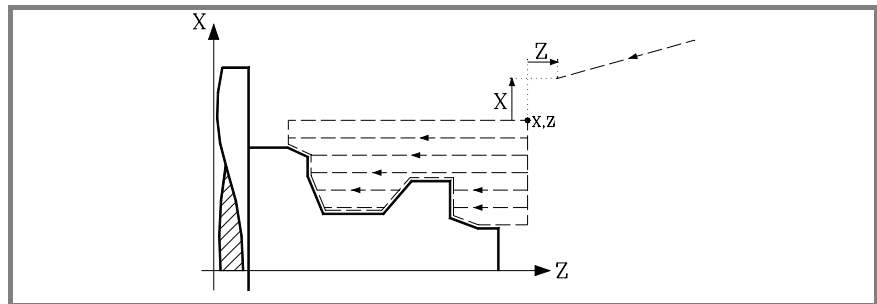

### Withdrawal distance at 45° (Ds).

The tool can withdraw to a safety distance after each pass. If the "Ds" data is validated, the display graphic changes and there is a withdrawal. This withdrawal is done at 45° (left figure).

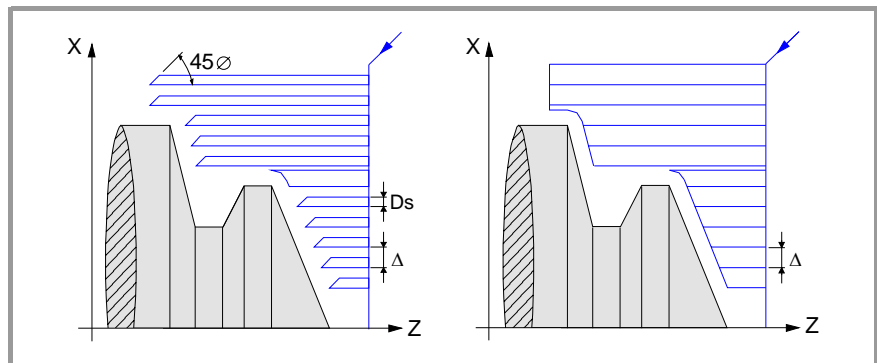

CNC 8055  
CNC 8055i

-TC- OPTION  
(SOFT: V16.1X)

### Machining direction.



The machining direction (turning direction or facing direction) is defined with the following icons. To select the desired type, place the cursor over this icon and press the two-color key.

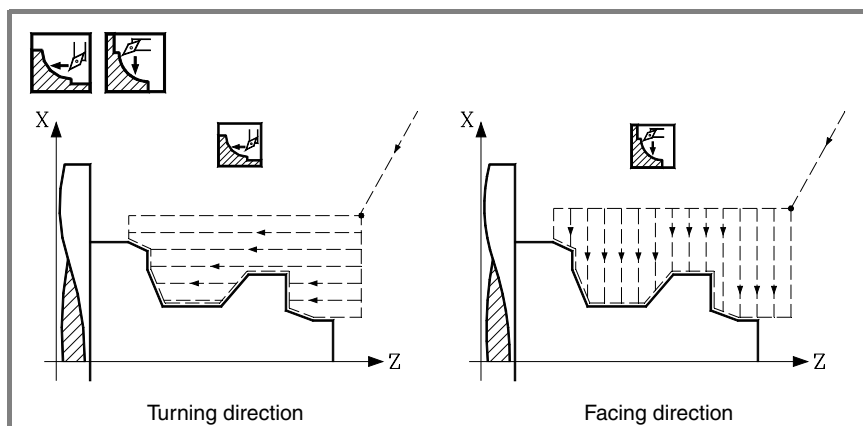

When changing the machining direction, the CNC changes the icon and shows the corresponding help screen.

### Finishing stocks in X-Z.

Either a single residual stock may be defined that is applied depending on the cutter's edge or 2 different ones, one for each axis (X, Z). It is selected with the following icon located in the finishing area.

- The figure on the left applies a finishing stock depending on the cutter's edge. The finishing stock is measured on the tool's cutting edge.
- The figure on the right lets define 2 finishing stocks, one per axis, regardless of the type of tool used.

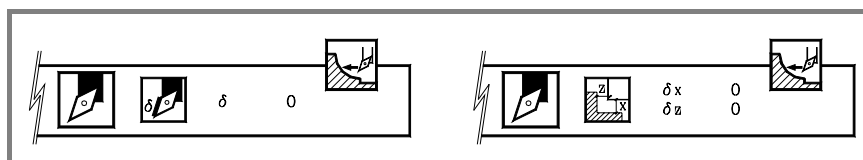

To select the type of finishing stocks, place the cursor over this icon and press the two-color key. To define these residual stocks, place the cursor on the corresponding data, key in the desired value and press [ENTER].

3.

WORKING WITH OPERATIONS OR CYCLES  
Profiling cycle

### 3.11.5 Definition of geometry at levels 3 and 4. XC, ZC profiles



**Milling with or without tool radius compensation.**

To select the type of compensation, place the cursor over this icon and press the two-color key.



Without compensation.



With lefthand tool radius compensation.



With righthand tool radius compensation.

When changing the type of profile, the CNC changes the icon and shows the corresponding help screen.

**Radius.**

It indicates the outside radius of the part. Place the cursor on this data, key in the desired value and press [ENTER].

**Total depth (Px).**

The total depth is programmed in radius and with a positive value (ZC profile). To define that value, place the cursor on this data, key in the desired value and press [ENTER].

**Penetrating feedrate (F).**

Place the cursor on this data, key in the desired value and press [ENTER].

**Safety distance.**

A part approach point may be set to prevent the tool from colliding with the part. The safety distance indicates the position of the approach point referred to the starting point.

To change one of these values, place the cursor on the corresponding data, key in the desired value and press [ENTER].

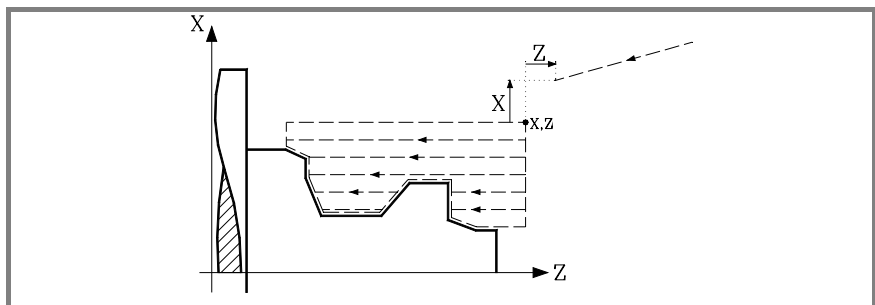

**Finishing stock at the bottom ( $\delta x$ ,  $\delta z$ ).**

The finishing stock at the bottom may be defined when working with tool radius compensation. To define these residual stocks, place the cursor on the corresponding data, key in the desired value and press [ENTER].

**Side stock ( $\delta$ ) and number of passes (N) to remove it.**

The side stock may be defined when working with tool radius compensation. To define these residual stocks, place the cursor on the corresponding data, key in the desired value and press [ENTER].

3.

WORKING WITH OPERATIONS OR CYCLES  
Profiling cycle



CNC 8055  
CNC 8055i

.TC- OPTION  
(SOFT: V16.1X)

### 3.11.6 Basic operation at levels 1 and 2. ZX profile

The machining steps for this cycle are:

1. If the operation has been programmed with another tool, the CNC will change the tool and will move to the change position if so required by the machine.
2. The spindle starts at the selected speed and in the indicated direction.
3. The tool approaches in rapid to the starting point (X, Z) keeping the selected safety distance in X and Z.

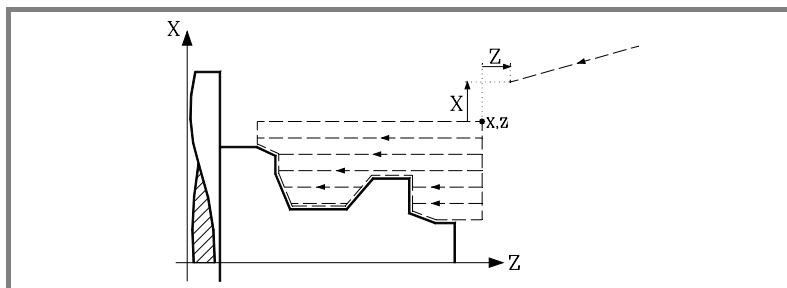

4. Roughing operation, with successive passes, up to a distance from the profile equal to the finishing stock.  
This operation is carried out under the conditions set for the roughing operation.
5. Finishing operation.  
If the finishing operation has been programmed with another tool, the CNC will change the tool and will move to the change position if so required by the machine.  
The finishing of the part is carried out with the machining conditions set for finishing; feedrate of the axes (F), spindle speed (S) and turning direction.
6. Once the operation or cycle has ended, the tool will return to the position it occupied when calling the cycle; i.e. to the point where [START] was pressed.  
When executing an entire part, combination of operations or cycles, the tool does not return to that point after executing each cycle.
7. The CNC stops the spindle, but it keeps the machining conditions set; tool (T), feedrate of the axes (F) and spindle speed (S).

#### Considerations

##### How to leave out the roughing or finishing operations.

By selecting T0 as the roughing tool, the cycle does not execute the roughing operation. In other words, after the approach movement, it will carry out the finishing operation.

By selecting T0 as the finishing tool, the cycle does not execute the finishing operation. In other words, after the roughing operation, the tool will move to the approach point maintaining the safety distance from the starting point (X, Z).

3.

WORKING WITH OPERATIONS OR CYCLES  
Profiling cycle

FAGOR 

CNC 8055  
CNC 8055i

.TC- OPTION  
(SOFT: V16.1X)

### 3.11.7 Basic operation at levels 3 and 4. XC, ZC profiles

The machining steps for this cycle are:

1. If the operation has been programmed with another tool, the CNC will change the tool and will move to the change position if so required by the machine.
2. The tool approaches in rapid to the starting point (X, Z) keeping the selected safety distance in X and Z.
3. Spindle orientation up to the indicated "C" position.
4. Roughing operation, with successive passes, up to a distance from the profile equal to the finishing stock.
5. Finishing operation.

If the finishing operation has been programmed with another tool, the CNC will change the tool and will move to the change position if so required by the machine.

Finishing of the bottom of the profile removing the bottom excess stock ( $\delta x$  or  $\delta z$ ). Then finishing of the side wall, removing the excess stock in successive passes.

The finishing of the part is carried out with the machining conditions set for finishing; feedrate of the axes (F), speed of the live tool.

6. Once the operation or cycle has ended, the tool will return to the position it occupied when calling the cycle; i.e. to the point where [START] was pressed.

When executing an entire part, combination of operations or cycles, the tool does not return to that point after executing each cycle.

3.

WORKING WITH OPERATIONS OR CYCLES  
Profiling cycle



CNC 8055  
CNC 8055i



.TC. OPTION  
(SOFT: V16.1X)



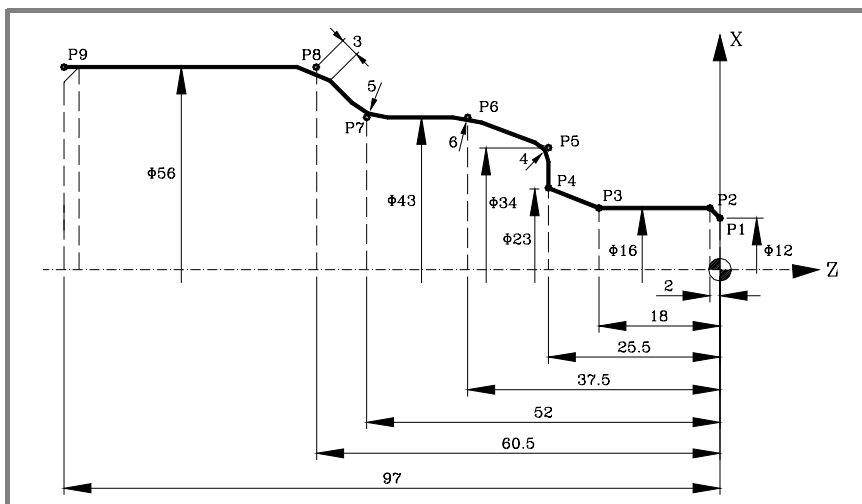







### 3.11.8 Example. Level 1



#### Geometry definition.

-  Outside profile.
-  Tool of machining.
-  Work quadrant.

#### Profile definition.

P1	X 12.0000		P6	X 43.0000	 R 6.0000
	Z -0.0000			Z -37.5000	
P2	X 16.0000		P7	X 43.0000	 R 5.0000
	Z -2.0000			Z -52.0000	
P3	X 16.0000		P8	X 56.0000	 C 3.0000
	Z -18.0000			Z -60.5000	
P4	X 23.0000		P9	X 56.0000	
	Z -25.5000			Z -97.0000	
P5	X 34.0000	 R 4.0000	P10	X 56.0000	
	Z -25.5000			Z -97.0000	

#### Coordinates (X, Z).

X 80.0000 Z 10.0000

#### Safety distance.

X 0.0000 Z 0.0000

#### Roughing.

F 1.000 S 1000 T 3 Δ 2



#### Finishing.

F 0.800 S 1000 T 3 δ 0.25

#### Spindle.

RPM 

3.

WORKING WITH OPERATIONS OR CYCLES  
Profiling cycle

FAGOR 

CNC 8055  
CNC 8055i

-TC- OPTION  
(SOFT: V16.1X)



### 3.11.9 Examples. Level 2

# 3.

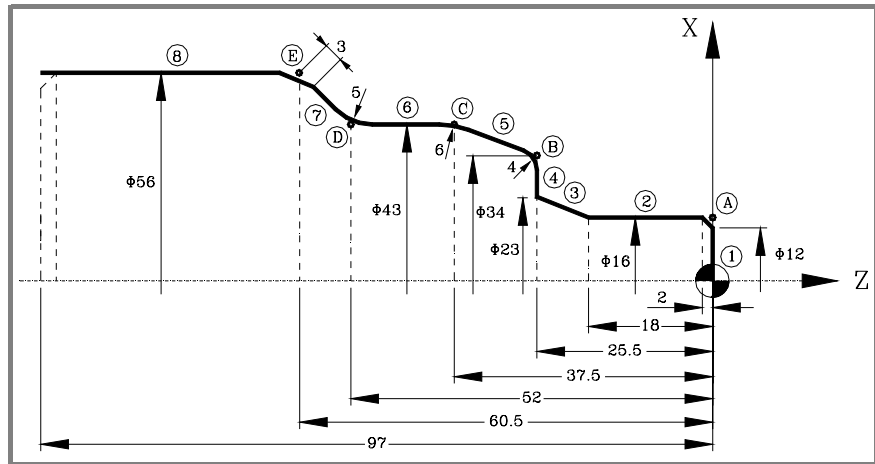
WORKING WITH OPERATIONS OR CYCLES  
Profiling cycle



#### Geometry definition.

-  Outside profile.
-  Tool of machining.
-  Work quadrant.

#### Profile definition.

Abscissa and ordinate of the starting point.		Z = 0	X = 0
Section 1	Straight	Z = 0	X = 16
Section 2	Straight	Z = -18	X = 16
Section 3	Straight	Z = -25.5	X = 23
Section 4	Straight	Z = -25.5	X = 34
Section 5	Straight	Z = -37.5	X = 43
Section 6	Straight	Z = -52	X = 43
Section 7	Straight	Z = -60.5	X = 56
Section 8	Straight	Z = -97	X = 56

#### Modify.

Chamfer	Select point "A". Press [ENTER] and assign to it Radius = 2.
Rounding	Select point "B". Press [ENTER] and assign to it Radius = 4.
Rounding	Select point "C". Press [ENTER] and assign to it Radius = 6.
Rounding	Select point "D". Press [ENTER] and assign to it Radius = 5.
Chamfer	Select point "E". Press [ENTER] and assign to it Radius = 3.

#### Coordinates (X, Z).

X 65.0000 Z 10.0000

#### Safety distance.

X 0.0000 Z 0.0000



CNC 8055  
CNC 8055i

.TC- OPTION  
(SOFT: V16.1X)

**Roughing.**

F 1.000 S 1000 T 3 Δ 2



**Finishing.**

F 0.800 S 1000 T 3 δ 0.25

**Spindle.**

RPM



**3.**

**WORKING WITH OPERATIONS OR CYCLES**  
Profiling cycle



CNC 8055  
CNC 8055i



.TC- OPTION  
(SOFT: V16.1X)

# 3.

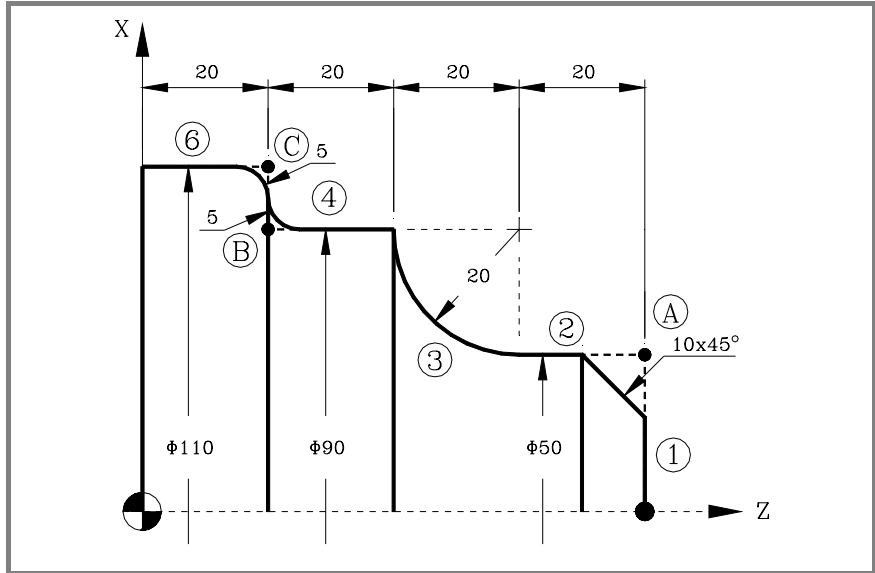
WORKING WITH OPERATIONS OR CYCLES  
Profiling cycle



**Geometry definition.**

-  Outside profile.
-  Tool of machining.
-  Work quadrant.

**Profile definition.**

Abscissa and ordinate of the starting point.		Z = 80	X = 0
Section 1	Straight	Z = 80	X = 50
Section 2	Straight	Z = 60	X = 50
Section 3	Clockwise arc	Z = 40	X = 90    Zc = 60    Xc = 90    R = 20
Section 4	Straight	Z = 20	X = 90
Section 5	Straight	Z = 20	X = 110
Section 6	Straight	Z = 0	X = 110

Modify.

Chamfer	Select point "A". Press [ENTER] and assign to it Radius = 10.
Rounding	Select point "B". Press [ENTER] and assign to it Radius = 5.
Rounding	Select point "C". Press [ENTER] and assign to it Radius = 5.

**Coordinates (X, Z).**

X 120.0000    Z 90.0000

**Safety distance.**

X 0.0000    Z 0.0000



CNC 8055  
CNC 8055i

-TC- OPTION  
(SOFT: V16.1X)

**Roughing.**

F 1.000    S 1000    T 3    Δ 2



**Finishing.**

F 0.800    S 1000    T 3    δ 0.25

**Spindle.**

RPM



**3.**

**WORKING WITH OPERATIONS OR CYCLES**  
Profiling cycle



**CNC 8055  
CNC 8055i**

.TC- OPTION  
(SOFT: V16.1X)



# 3.

WORKING WITH OPERATIONS OR CYCLES

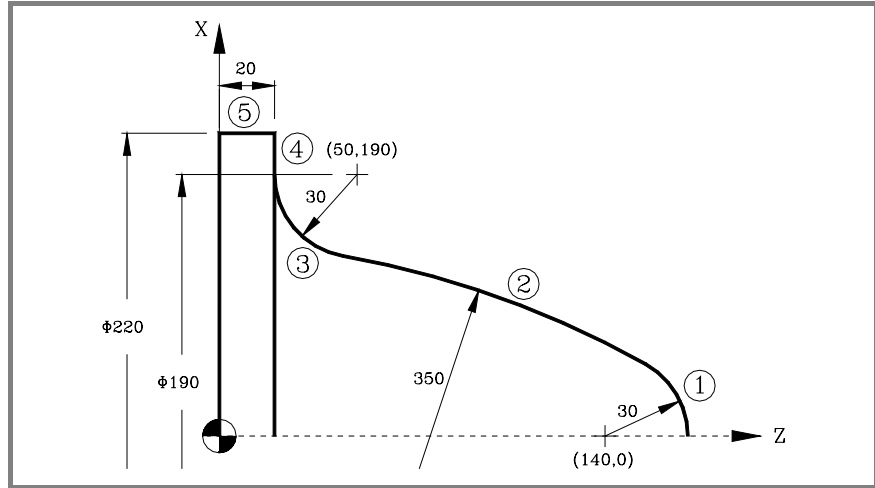
Profiling cycle



**Geometry definition.**

-  Outside profile.
-  Tool of machining.
-  Work quadrant.

**Profile definition.**

Abscissa and ordinate of the starting point.		Z = 170	X = 0
Section 1	Counterclockwise arc	Zc = 140	Xc= 0 R = 30
Section 2	Counterclockwise arc		R = 350 Tangent = Yes
The CNC displays the possible options for section 2. Select the right one.			
Section 4	Straight	Z = 20	X = 220 Tangent = Yes
The CNC shows the possible options between sections 3 and 4. Select the correct one.			
Section 5	Straight	Z = 0	X = 220

**Coordinates (X, Z).**

X 230.0000 Z 180.0000

**Safety distance.**

X 0.0000 Z 0.0000

**Roughing.**

F 1.000 S 1000 T 3 Δ 2



**Finishing.**

F 0.800 S 1000 T 3 δ 0.25

**Spindle.**

RPM



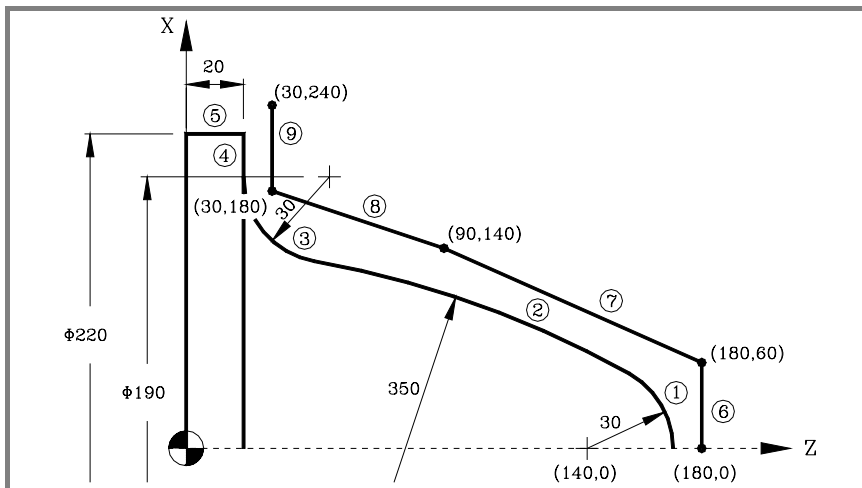

CNC 8055  
CNC 8055i

-TC- OPTION  
(SOFT: V16.1X)



**Geometry definition.**

-  Outside profile.
-  Tool of machining.
-  Work quadrant.

**Profile definition.**

Abscissa and ordinate of the starting point.		Z = 170	X = 0
Section 1	Counterclockwise arc	Zc = 140	Xc = 0 R = 30
Section 2	Counterclockwise arc	R = 350	Tangent = Yes
Section 3	Clockwise arc	Zc = 50	Xc = 190 R = 30
The CNC displays the possible options for section 2. Select the right one.			
Section 4	Straight	Z = 20	X = 220
The CNC shows the possible options between sections 3 and 4. Select the correct one.			
Section 5	Straight	Z = 0	X = 220

**Definition of the profile of the original stock (new profile).**

Abscissa and ordinate of the starting point.		Z = 180	X = 0
Section 6	Straight	Z = 180	X = 60
Section 7	Straight	Z = 90	X = 140
Section 8	Straight	Z = 30	X = 180
Section 9	Straight	Z = 30	X = 240

**Coordinates (X, Z).**

X 230.0000 Z 180.0000

**Safety distance.**

X 0.0000 Z 0.0000

**3.**

WORKING WITH OPERATIONS OR CYCLES  
Profiling cycle



CNC 8055  
CNC 8055i

.TC. OPTION  
(SOFT: V16.1x)

# 3.

## WORKING WITH OPERATIONS OR CYCLES Profiling cycle

### **Roughing.**

F 1.000    S 1000    T 3    Δ 2



### **Finishing.**

F 0.800    S 1000    T 3    δ 0.25

### **Spindle.**

RPM





CNC 8055  
CNC 8055i

-TC- OPTION  
(SOFT: V16.1X)

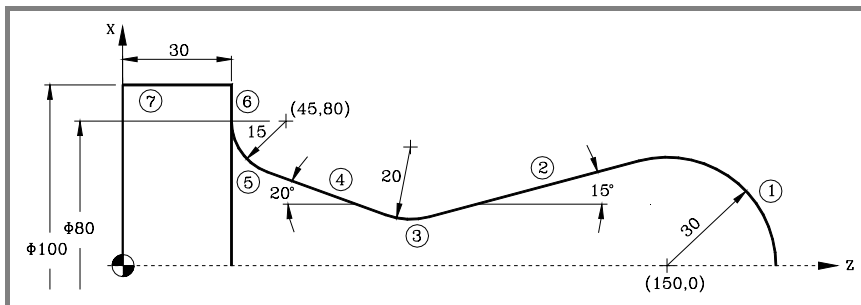



**Geometry definition.**

-  Outside profile.
-  Tool of machining.
-  Work quadrant.

**Profile definition.**

Abscissa and ordinate of the starting point. $Z = 180$ $X = 0$				
Section 1	Counterclockwise arc	$Zc = 150$	$Xc = 0$	$R = 30$
Section 2	Straight	Angle = 195		Tangent = Yes
The CNC shows the possible options between sections 1-2. Select the correct one.				
Section 3	Clockwise arc	$R = 20$		Tangent = Yes
Section 4	Straight	Angle = 160		Tangent = Yes
Section 5	Clockwise arc	$Z = 30$	$Zc = 45$	$R = 15$ Tangent = Yes
		$X = 80$	$Xc = 80$	
The CNC shows the possible options between sections 4-5. Select the correct one.				
The CNC displays the possible options for section 3. Select the right one				
Section 6	Straight	$Z = 30$	$X = 100$	
Section 7	Straight	$Z = 0$	$X = 100$	

**Coordinates (X, Z).**

X 110.0000 Z 190.0000

**Safety distance.**

X 0.0000 Z 0.0000

**Roughing.**

F 1.000 S 1000 T 3 Δ 2



**Finishing.**

F 0.800 S 1000 T 3 δ 0.25

**Spindle.**

RPM



**3.**

WORKING WITH OPERATIONS OR CYCLES  
Profiling cycle



CNC 8055  
CNC 8055i

.TC- OPTION  
(SOFT: V16.1X)



# 3.

WORKING WITH OPERATIONS OR CYCLES

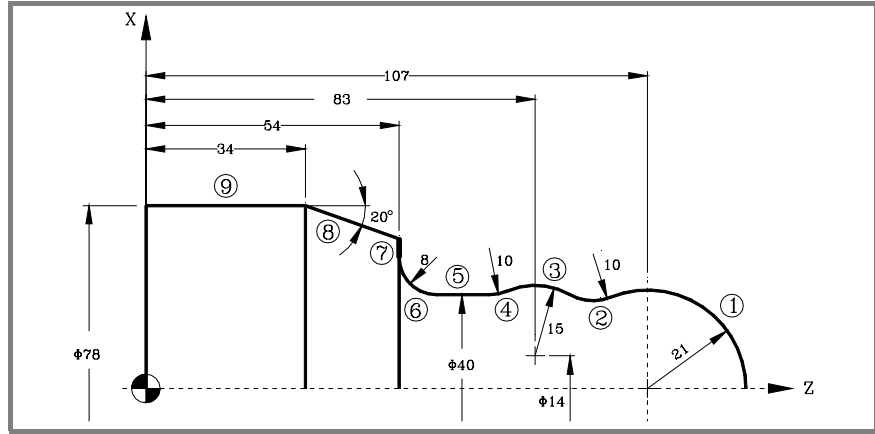
Profiling cycle



**Geometry definition.**

-  Outside profile.
-  Tool of machining.
-  Work quadrant.

**Profile definition.**

Abscissa and ordinate of the starting point.		Z = 128	X = 0
Section 1	Counterclockwise arc	Zc = 107	Xc = 0 R = 21
Section 2	Clockwise arc	R = 10	Tangent = Yes
The CNC displays the possible options for section 2. Select the right one			
Section 4	Clockwise arc	R = 10	Tangent = Yes
Section 5	Straight	X = 40	Angle = 180 Tangent = Yes
The CNC displays the possible options for section 4. Select the right one			
Section 6	Clockwise arc	Z = 54	
X = 56	Zc = 62		
Xc = 56	R = 8		Tangent = Yes
Section 7	Straight	Z = 54	Angle = 90 Tangent = Yes
Section 8	Straight	Z = 34	X = 78 Angle = 160
Section 9	Straight	Z = 0	X = 78

**Coordinates (X, Z).**

X 85.0000 Z 135.0000

**Safety distance.**

X 0.0000 Z 0.0000

**Roughing.**

F 1.000 S 1000 T 3 Δ 2



**Finishing.**

F 0.800 S 1000 T 3 δ 0.25



CNC 8055  
CNC 8055i

-TC- OPTION  
(SOFT: V16.1X)

**Spindle.**

RPM



**3.**

**WORKING WITH OPERATIONS OR CYCLES**  
Profiling cycle



**CNC 8055**  
**CNC 8055i**

.TC- OPTION  
(SOFT: V16.1X)

# 3.

## WORKING WITH OPERATIONS OR CYCLES

Profiling cycle



CNC 8055  
CNC 8055i

.TC. OPTION  
(SOFT: V16.1X)

Without the Y axis option, the Y axis will only be available without cycles, calibration or Y axis compensation.

Both for programming and displaying, the Y axis format will always be determined as radius, not as diameter.

## 4.1 Profiling cycles with Y axis

Profile cycles in YZ and XY may be accessed with their relevant icons from either of the two levels of profile cycles ZC and XC respectively.

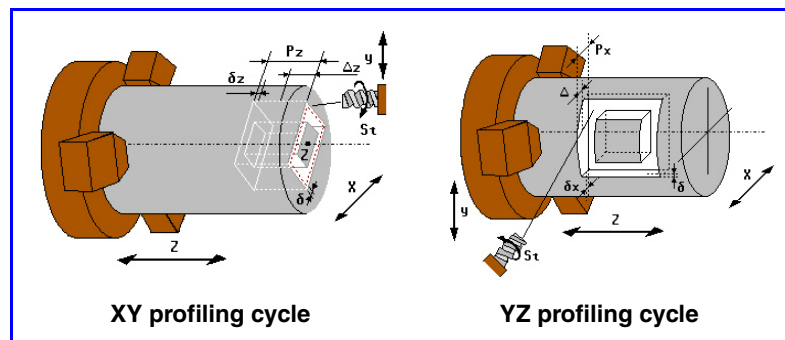

This icon selects the planes of the Y axis (YZ, XY). Selecting a plane of the Y axis changes the graphics on the screen.

The parameters of the cycles in the Y axis planes are equivalent to those in the C plane (ZC, XC), except for the radius (R) of the ZC profile that is not used in the YZ plane and it uses the X coordinate, instead.

A data is added in the two cycles that use the Y axis to indicate the starting angle of the spindle (W).

## 4.2 Graphics: XY and ZY plane selection

The XY and ZY planes may be selected using the relevant softkeys shown in the <graphics> window similar to that of the C axis planes, XC and ZC.

## 4.3 Tool calibration

There are three tool calibration levels in conversational TC mode managing the Y axis:

► **Level 1: Manual tool calibration and with a probe.**

Selecting the manual tool calibration using a known part shows, with Y axis, the following screen:

**4.**  
Y AXIS  
Tool calibration

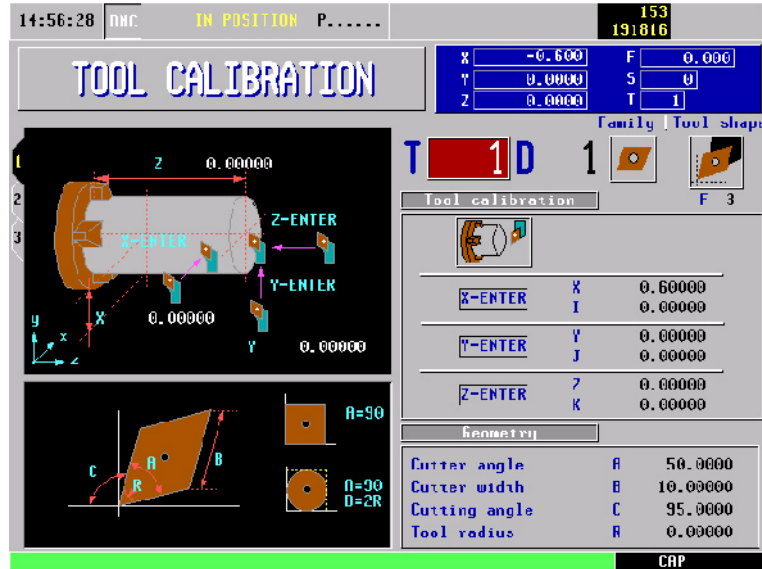

Observe that the <tool calibration> area of this window shows the label "Y-ENTER" and the "Y" and "J" fields.

To make the measurement, once the tool has been moved manually until touching the part and [ENTER] is pressed inside the Y field, the CNC calculates the new length and assigns it to the field of the active tool offset. Parameter J is set to 0.

Selecting the manual tool calibration using a probe shows, with Y axis, the following screen:

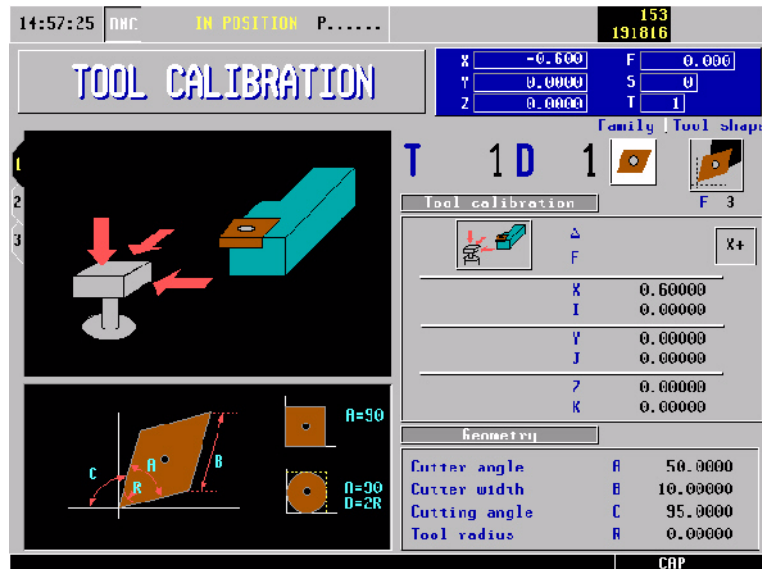

When having a Y axis, just like with the rest of the axes, it is possible to enter the approach distance "Δ", the approach feedrate "F" and the side of the probe being probed "Y+" or "Y-". If no value is entered for "Δ", it takes the value of g.m.p. PRBMODE. Likewise, if no value is entered for "F", it takes the value of a.m.p. PRBFEEED.

Observe that the <tool calibration> area of this window shows the "Y" and "J" fields and the icon "Y+", "Y-".

When done probing, the CNC calculates the new length that is updated in the Y field on the screen. Parameter J is set to 0.



CNC 8055  
CNC 8055i

-TC- OPTION  
(SOFT: V16.1X)

► **Level 2: Tool calibration with probing cycles.**

Selecting the tool calibration using probing cycles shows, with Y axis, the following screen:

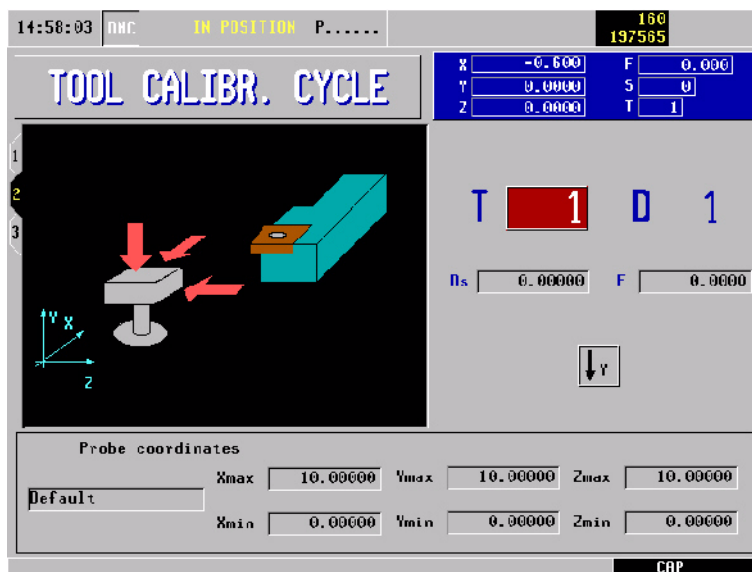

The < ↓ Y > icon turns on or off the display of the probe's Y coordinates at the bottom of the screen. When selecting "display the Y axis", the calibration is also carried out on this axes. The Y axis coordinates will be displayed by default.

► **Level 3: Probe calibration.**

Selecting the probe calibration shows, with Y axis, the following screen:

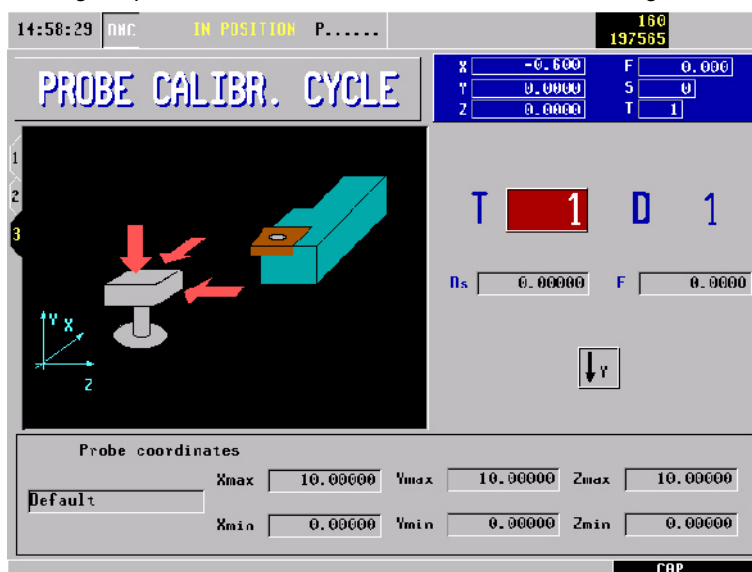

The < ↓ Y > icon turns on or off the display of the probe's Y coordinates at the bottom of the screen. The Y axis coordinates will be displayed by default.

**4.**  
Y AXIS  
Tool calibration



CNC 8055  
CNC 8055i

.TC- OPTION  
(SOFT: V16.1X)

# 4.

## Y AXIS

Tool calibration



CNC 8055  
CNC 8055i

.TC. OPTION  
(SOFT: V16.1x)



The ISO mode is accessed with the [ISO] key.

- When operating with operations or cycles, press the [ISO] key once.
- When operating in jog mode, press the [ISO] key twice; the first time to access the MDI mode and the second time to access the ISO mode. See ["2.11 ISO management"](#) on page 51.

## Cycle levels

The ISO mode offers several editing levels. Each level has its own screen and the main window of the cycle indicates, with tabs, the available levels and which one is selected.

LEVEL  
CYCLE

To change levels, use the [LEVEL CYCLE] key or the [page up] and [page down] keys to scroll up and down through the various levels.

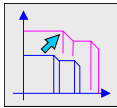
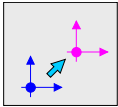
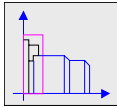
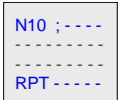
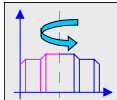
	Block editing		Scaling factor
	Zero offsets and presets		Work zones
	Place labels and repetitions from label to label		Mirror image

## Simulating, executing or saving ISO cycles

Once the cycle data or the blocks have been edited, press [ESC]. The upper right side of the screen will show the "start" symbol. From this moment on, the edited blocks may be simulated, executed or saved like any operation or cycle.



- To simulate the blocks, press the [GRAPHICS] key.
- To execute the blocks, press the [START] key.
- To save the edited blocks, press the [P.PROG] key.

It is possible to combine ISO-coded blocks with standard and/or user machining cycles to create part-programs. See chapter ["6 Saving programs"](#).

## 5.1 Editing blocks in ISO mode

When accessing the ISO mode, the CNC displays a special screen for editing up to 6 program blocks either in ISO code or in high level language. After editing a block, press [ENTER] to validate it.

**Example:**

ISO	
G95 G96 S120 M3	
G0 Z100	
G1 X30 F0.1	

Once the block or blocks have been edited, press [ESC]. The upper right side of the screen will show the "start" symbol. From this moment one, the edited blocks may be simulated, executed or saved like any operation or cycle.

# 5.

**OPERATING IN ISO MODE**  
Editing blocks in ISO mode



CNC 8055  
CNC 8055i

.TC. OPTION  
(SOFT: V16.1X)

## 5.2 Programming assistance

### 5.2.1 Zero offsets and presets

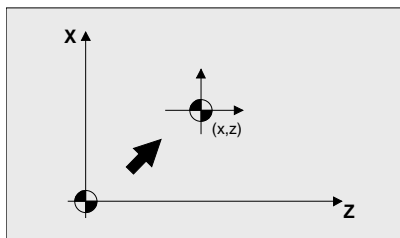

The icon may be used to select the following options:

- Machine zero. It cancels any zero offset and assumes the machine zero (home) as reference.
- Absolute zero offset. It permits defining, enabling or defining + enabling the absolute zero offsets (G54 ... G57, G159N7 ... G159N20).
- The zero offset is selected with an icon.
- Incremental offset: It permits defining, enabling or defining + enabling the incremental zero offsets (G58 or G59). The zero offset to be activated is selected with an icon.
- Preset: The preset value for the active axes may be edited on the screen. If any of them is not to be preset, leave its field empty.

The cycle internally generates a block with function G53, G54...G59, G159N7...G159N20 or G92.

Pressing the [ZERO] key accesses the zero offset table.

### 5.2.2 Work zones

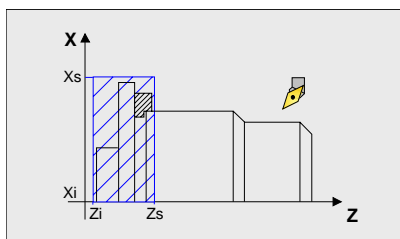

The icons may be used to defined the following options:

- Select the work zone to act upon. Up to five different zones may be defined.
- Type of action to carry out with the zone. A zone may be defined, enabled, defined+enabled or disabled.
- Define the type of zone. Each one of them may be defined either as a no-entry or no-exit zone.

The numeric fields permit editing the lower and upper limits of the zone. The limits are defined on the X, Z axes. To only define either the upper or the lower limit, leave the values of the other limit blank.

The cycle internally generates up to three blocks with functions G20, G21 and G22.

### 5.2.3 Place labels and repetitions from label to label

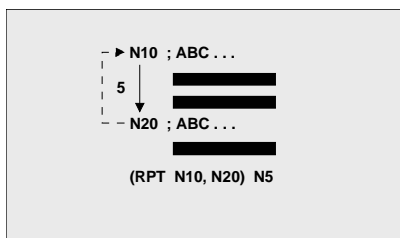

This cycle permits editing labels and repetition blocks between two labels. It is selected with an icon.

- Edit labels. There is a field to enter the block number and another one to add a comment.

The cycle generates this type of a block: N10; -> Comment

- Block repetition. The repetition takes place between the first and final labels programmed, the number of times that is indicated.

The cycle internally generates an RPT block.

5.

OPERATING IN ISO MODE  
Programming assistance

FAGOR

CNC 8055  
CNC 8055i

.TC- OPTION  
(SOFT: V16.1X)

## 5.2.4 Mirror image

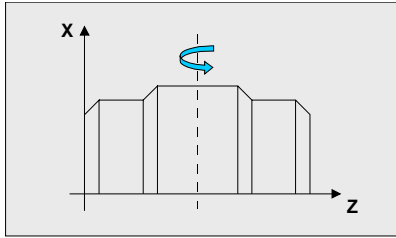

The icons may be used to select the following options:

- Select the action to be carried out. It is possible to cancel the active mirror image, define a new one canceling the previous ones or define a new one and add it to the one that is currently active.
- Select the axes upon which mirror image is applied. This icon is not displayed if mirror image cancellation has been selected.

The cycle internally generates an ISO block that contains a combination of functions G10, G11 and G12.

## 5.2.5 Scaling factor

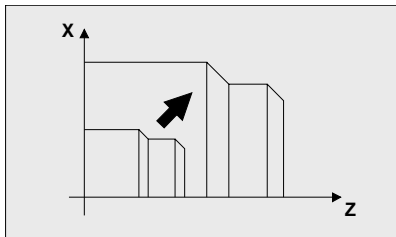

An icon is used to indicate whether to cancel the existing scaling factor or activate a new one. In the latter case, a numeric field is displayed to define the value of the scaling factor.

The cycle internally generates a block with function G72.

5.

OPERATING IN ISO MODE  
Programming assistance



CNC 8055  
CNC 8055i

-TC- OPTION  
(SOFT: V16.1X)

Part-programs may be edited, simulated and executed.

Each one of these programs is made up by concatenating simple operations or cycles and/or blocks edited in ISO code. Chapter **"3 Working with operations or cycles"** describes how to edit or define those operations or cycles.

This chapter indicates how to operate with those part-programs through the following sections and sub-sections.

- List of saved programs.
- Seeing the contents of a program.
- Editing a new part-program.
- Saving an ISO block or a cycle.
- Deleting a new part program.
- Copying a part-program into another one.
- Modifying a part-program.
- Managing programs using the explorer

## 6.1 List of saved programs



Press [P.PROG] to access the list of saved part-programs.

It is not possible to access the list of part-programs directly if the "Tool calibration" mode is selected. First, quit this mode; in other words, first press [ESC] and then [P.PROG].

The CNC will display the following information:

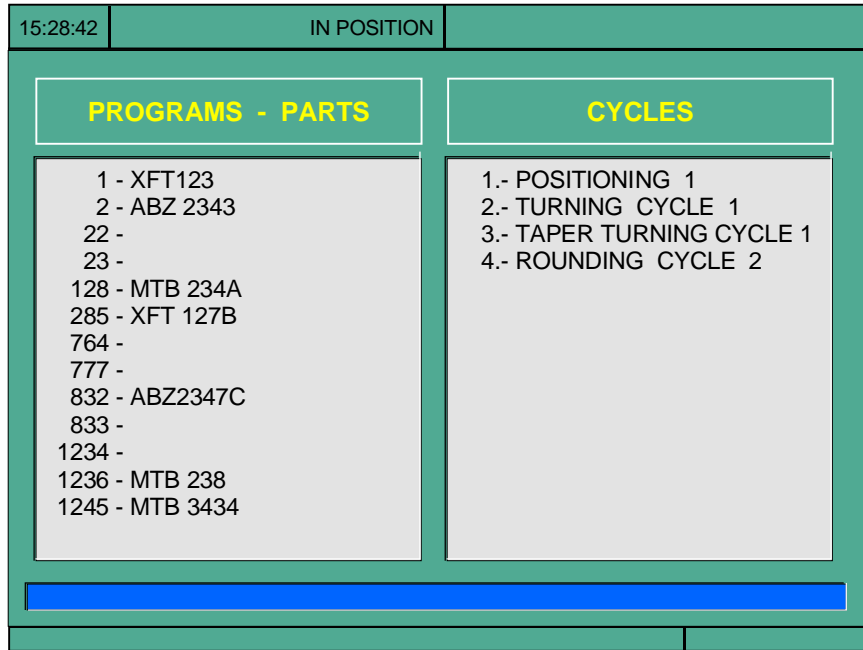

Press one of these keys to exit the directory or list of part-programs:

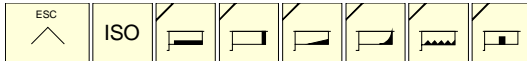

### List of part-programs.

The left side shows the list of part-programs that are saved in the CNC's memory. Use the [↑][↓] keys to move the pointer over the list of programs. Use the [SHIFT][↑] y [SHIFT][↓] keys to scroll a page at a time.

It is possible to select the program by typing its number directly. If the desired program does not exist, the cursor will go to the nearest previous one. For example, to find program number 123, press the keystroke sequence [1], [2] and [3]. The time interval between keystrokes must be shorter than 1.5 seconds. A longer interval starts a new sequence.

### Cycles that make up the part-program.

The right column shows the cycles and/or blocks edited in ISO code that make up the part. Once the list of programs has been selected, the following operations are possible:

- Creating a new part-program.
- Seeing the contents of a part-program.
- Deleting a new part program.
- Copying a part-program into another one.
- Modifying a part-program.

**6.**  
**SAVING PROGRAMS**  
 List of saved programs



CNC 8055  
 CNC 8055i

.TC- OPTION  
 (SOFT: V16.1X)

## 6.2 See the contents of a program

To see the contents of a part-program, select it on the left column using the pointer. To do that, use the [↑][↓] keys. The right column shows the cycles that make up the part.



When pressing [ENTER] or one of the [←][→] keys, the pointer switches to the right column. Now, the [↑][↓] keys may be used to move the pointer over the blocks or cycles that make up the part.



*So, use the [↑][↓] keys to move up and down on each column and [←][→] keys to switch columns.*

Once an operation has been selected, the following is possible:

- To see the operation in detail.
- To delete the operation.
- To move the operation to another position.
- To modify the operation.

### 6.2.1 Seeing one of the operations in detail



Once the desired operation has been selected using the pointer, press [RECALL]. The CNC will show all the data for that operation.

In this moment it is possible to:

- Simulate the operation. See chapter "[7 Execution and simulation](#)".
- Execute the operation. See chapter "[7 Execution and simulation](#)".
- To modify the operation.
- Save the operation. Replacing the previous one or inserting it as a new one.

6.

**SAVING PROGRAMS**  
See the contents of a program

**FAGOR**

CNC 8055  
CNC 8055i

-TC- OPTION  
(SOFT: V16.1X)

## 6.3 Edit a new part-program

To edit a new program, proceed as follows:



1. Press [P.PROG] to access the list of part-programs stored.
2. Select, with the pointer, the option "Creating new part" on the left column.
3. Press the [P.PROG] key. The bottom of the screen will request the number to be assigned to the new part-program and it will offer the first one available.



4. Enter the number of the desired program and press [ENTER].  
It must be a number between 1 and 899999, both included.
5. The CNC requests the comment to be associated with the part-program.  
It is not necessary to associate a comment.



6. Press the [ENTER] or [ESC].  
The CNC includes the new part-program in the list (left column).

From this moment on, all the desired operations may be saved in the desired order.

# 6.

**SAVING PROGRAMS**  
Edit a new part-program



CNC 8055  
CNC 8055i

-TC- OPTION  
(SOFT: V16.1X)



## 6.4 Saving an ISO block or a cycle

The block or cycle may be added at the end of the program, after the last operation or insert it between 2 existing operations.

To save the block or cycle, proceed as follows:

1. Define the desired block or cycle assigning the relevant data to it.
2. Press [P.PROG] to access the list of part-programs stored.
3. Select, with the pointer, the desired program number on the left column and switch over to the right column.
4. Place the pointer on the operation after which the block or cycle is to be saved and press [ENTER].

Example:

Current program	Desired program
Positioning cycle 2	Positioning cycle 2
Facing cycle	Facing cycle
Taper turning cycle 2	Taper turning cycle 2
	Turning cycle
Rounding cycle 2	Rounding cycle 2
Taper turning cycle 1	Taper turning cycle 1
	Threading cycle 1

To insert the "turning cycle" operation, once the operation has been defined, place the pointer on the "taper turning cycle 2" operation and press [ENTER].

To insert the "threading cycle 1" operation, once the operation has been defined, place the pointer on the last "taper turning cycle 1" operation and press [ENTER].

# 6.

**SAVING PROGRAMS**  
Saving an ISO block or a cycle



CNC 8055  
CNC 8055i

.TC- OPTION  
(SOFT: V16.1X)

## 6.5 Delete a new part program

To delete a part-program, proceed as follows:

1. Press [P.PROG] to access the list of part-programs stored.
2. Select, with the pointer, the part-program to be deleted from the left column.
3. Press [CLEAR].



The bottom of the screen will show a message requesting confirmation of the deleting operation.

- If [ENTER] is pressed, the CNC will delete the selected program and will update the list of saved programs.
- If [ESC] is pressed, the program will not be deleted and it will quit deleting operation.

6.

**SAVING PROGRAMS**

Delete a new part program



CNC 8055  
CNC 8055i

-TC- OPTION  
(SOFT: V16.1X)

## 6.6 Copying a part-program into another one

To copy a part-program into another one, proceed as follows:

1. Press [P.PROG] to access the list of part-programs stored.
2. Select, with the pointer, the part-program to be copied from the left column.
3. Press the [P.PROG] key.  
The bottom of the screen will show a message requesting the number to be assigned to the copy.
4. Enter the number of the desired program and press [ENTER].  
It must be a number between 1 and 899999, both included.
5. If there is already a part-program with that number, the bottom of the screen will show a message asking to either replace it or cancel the operation?  
If [ENTER] is pressed, the CNC will request a new program. If [ESC] is pressed, the CNC will not delete the current program and will copy the program.
6. The CNC requests the comment to be associated with the new part-program (the copy).  
It is not necessary to associate a comment.
7. Press the [ENTER] or [ESC]. The CNC updates the list of saved part-programs.

# 6.

## SAVING PROGRAMS

Copying a part-program into another one

**FAGOR** 

CNC 8055  
CNC 8055i

.TC- OPTION  
(SOFT: V16.1X)

## 6.7 Modify a part-program

**6.**  
**SAVING PROGRAMS**  
 Modify a part-program

To modify a part-program, proceed as follows:

1. Press [P.PROG] to access the list of part-programs stored.
2. Select, with the pointer, the part-program to be modified from the left column.

Once the program has been selected, the following operations are possible:

- To delete an operation.
- To move an operation to another position.
- To add or insert a new operation.
- To modify an existing operation.

### 6.7.1 Delete an operation

To delete an operation, proceed as follows:

1. Select, with the pointer, the operation to be deleted from the right column.
2. Press [CLEAR].

The bottom of the screen will show a message requesting confirmation of the deleting operation.

- If [ENTER] is pressed, the CNC will delete the selected operation and will update the right column.
- If [ESC] is pressed, the operation will not be deleted and it will quit deleting operation.

### 6.7.2 Add or insert a new operation

To add or insert an operation follow the same steps as for saving an operation.

1. Define the desired block or cycle assigning the relevant data to it.
2. Press [P.PROG] to access the list of part-programs stored.
3. Place the pointer on the operation after which the block or cycle is to be saved and press [ENTER].



CNC 8055  
 CNC 8055i

.TC- OPTION  
 (SOFT: V16.1X)

### 6.7.3 Move an operation to another position

To move an operation to another position, proceed as follows:

1. Select, with the pointer, the operation to be moved from the right column.
2. Press the two-color key.  
The CNC will highlight that operation.
3. Place the cursor on the operation after which the operation is to be placed and press [ENTER].



Example:

Current program	Desired program
Positioning cycle 2	Positioning cycle 2
Facing cycle	Taper turning cycle 2
Taper turning cycle 2	Turning cycle
Turning cycle	Rounding cycle 2
Rounding cycle 2	Taper turning cycle 1
Taper turning cycle 1	Facing cycle
Threading cycle 1	Threading cycle 1

Select the "facing cycle" operation and press the two-color key. Then position the cursor on the "taper turning cycle 1" operation and press [ENTER].

## 6.

**SAVING PROGRAMS**  
Modify a part-program



CNC 8055  
CNC 8055i

.TC- OPTION  
(SOFT: V16.1X)

## 6.7.4 Modify an existing operation

To modify an operation, proceed as follows:

1. Select, with the pointer, the block or cycle to be modified from the right column.
2. Press the [RECALL] key.  
The CNC will show the editing page for that operation.
3. Modify all the desired data.

To save the modified operation, proceed as follows:

1. Press [P.PROG] to access the list of part-programs stored.  
The CNC shows the pointer on the same operation. To select another position, use the [↑][↓] keys. The new operation will be inserted after the selected operation.
2. Press the [ENTER] key.

To place the modified operation in its previous location, the CNC will show a message asking to either replace the previous operation or keep it inserting the new one after it.

The following example modifies the "facing cycle" operation:

Current program	Option "Replace"	Option "Insert"
1.- Facing cycle	1.- Facing cycle	1.- Facing cycle
2.- Taper turning cycle 2	2.- Taper turning cycle 2	2.- Facing cycle
		3.- Taper turning cycle 2



*It is possible to select an existing operation, modify it and then insert it in another position and even in another part-program.*

**6.**  
**SAVING PROGRAMS**  
Modify a part-program



CNC 8055  
CNC 8055i

.TC- OPTION  
(SOFT: V16.1X)

## 6.8 Managing programs using the explorer

Windows Explorer may be accessed from the PPROG screen by placing the cursor in the "user programs" area and pressing [RECALL]. Pressing the [ESC] key returns to the PPROG screen.

Accessing the explorer displays a window divided in two areas (left panel and right panel) as shown in the next figure:

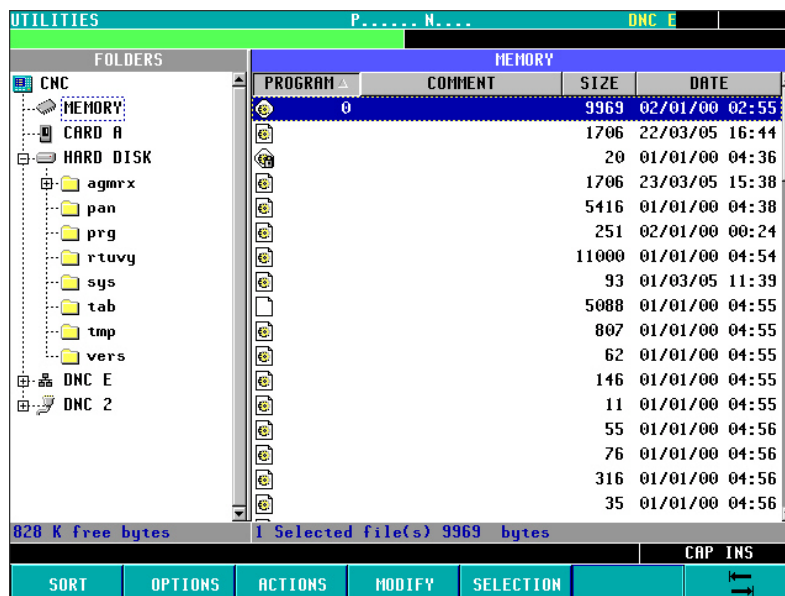

Once in the explorer, it will be possible to select any program of the Ram memory or hard disk (KeyCF) to edit it or execute it. When selecting the hard disk (KeyCF), the CNC will select the PRG folder automatically because it is the only folder where programs may be executed.



*When selecting programs of the hard disk (KeyCF), only programs from the PRG folder may be selected.*

When returning from the explorer to the PPROG screen with a different device, the CNC will display a message warning that the device has been changed and requesting confirmation.

Once out of the explorer, the CNC will show an indicator of the device that has been selected. This indicator will appear to the left of the selected program.



*The subroutines and profiles defined in the profile cycles (the profiles defined in the cycle as well as the associated profile programs) must be in user RAM memory although the call to the cycle may be in a program of the hard disk (KeyCF).*

*Programs contained in MemKeyCard, hard disk module, USB or in DNC (infinite program) can be neither edited nor executed.*

*The selected device will be maintained even after turning the CNC off or after a Shift/Reset.*

# 6.

## SAVING PROGRAMS

Managing programs using the explorer



CNC 8055  
CNC 8055i

.TC- OPTION  
(SOFT: V16.1X)

# 6.

## SAVING PROGRAMS

Managing programs using the explorer



CNC 8055  
CNC 8055i

.TC. OPTION  
(SOFT: V16.1X)



# EXECUTION AND SIMULATION

# 7

The simulation may be used to graphically show a part-program or an operation with the data used to define it. This way, the simulation may be used to check the part-program or the operation before executing it or saving it and, therefore, correct or modify its data.



It is possible to execute or simulate a part-program or any operation. The simulation or execution may be done from beginning to end or step by step by pressing the [SINGLE] key.

It is possible to simulate or execute:

- An operation or Cycle.
- A part-program.
- An operation saved as part of a part-program.

## Selecting a program for simulation or execution

When selecting a part-program or operation saved as part of a part-program for simulation or execution, the CNC selects that part-program and shows it highlighted next to the green "start" symbol in the top center window.

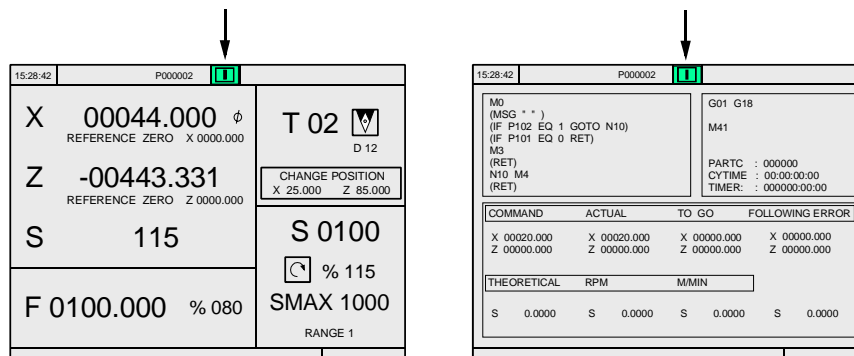

When the top center window shows the part-program selected next to the green "start" symbol, the CNC acts as follows:

- If [START] is pressed, the CNC executes the part-program that is selected.
- If [CLEAR] is pressed, the CNC de-selects the part-program and removes it from the top center window.



CNC 8055  
CNC 8055i

.TC- OPTION  
(SOFT: V16.1X)

## 7.1 Simulating or executing an operation or cycle

All the operations or cycles have 2 work modes; execution and editing.

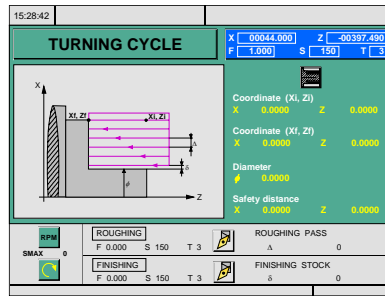

Editing mode

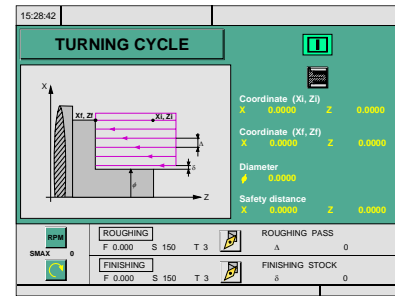

Execution mode

# 7.

EXECUTION AND SIMULATION  
Simulating or executing an operation or cycle

### Simulation



The operation or cycle may be simulated in both work modes. To do that, press the [GRAPHICS] key. The CNC shows the graphic screen of the T model.

### Execution

An operation or cycle can only be executed in the cycle execution mode.

The operation or cycle cannot be executed when the cycle editing mode is selected. Press [ESC] to quit the editing mode and switch to execution mode.



Press [START] to execute an operation or cycle.



CNC 8055  
CNC 8055i

.TC· OPTION  
(SOFT: V16.1X)

## 7.2 Simulating or executing a part-program

Proceed as follows to simulate or execute a part-program:

1. Press [P.PROG] to access the list of part-programs stored.
2. Select on the left column the program to be simulated or executed.

Press [GRAPHICS] to simulate the part-program and [START] to execute it. When executing a program, the CNC executes the initial subroutine 9998 and the final subroutine 9999.

If an error occurs in a cycle during simulation or execution, when accessing the list of programs again, the cursor will be placed on the cycle that came up with the error. When program 999998 is displayed on the screen or the error is not an execution error, the cursor will go to the beginning or to the end of the program depending on its length.

### 7.2.1 Simulating or executing a portion of a part-program

Proceed as follows to simulate or execute a portion of a part-program:

1. Press [P.PROG] to access the list of part-programs stored.
2. Select the program from the left column and the operation (on the right column) from which to begin executing or simulating the part program.

Press [GRAPHICS] to simulate the selected portion and [START] to execute it. When executing a portion of a program, the CNC does not execute the initial subroutine 9998, but it executes the final subroutine 9999. If the program is executed from the first operation on, it executes both subroutines.

7.

EXECUTION AND SIMULATION  
Simulating or executing a part-program

**FAGOR** 

CNC 8055  
CNC 8055i

.TC· OPTION  
(SOFT: V16.1X)

## 7.3 Simulating or executing an operation that has been saved

Proceed as follows to simulate or execute an operation that has been saved as a part of program:

1. Press [P.PROG] to access the list of part-programs stored.
2. Select the program that contains it from the left column and the operation to be simulated or executed from the right column.
3. Press the [RECALL] key.

Press [GRAPHICS] to simulate the operation and [START] to execute it.

7.

**EXECUTION AND SIMULATION**

Simulating or executing an operation that has been saved



CNC 8055  
CNC 8055i

.TC· OPTION  
(SOFT: V16.1X)

## 7.4 Execution mode



When pressing [START] to execute an operation or part-program, the CNC shows the standard screen of the TC mode.

15:28:42		P000002		
X	00044.000	$\phi$	T 02	
	REFERENCE ZERO	X 0000.000		D 12
Z	-00443.331		CHANGE POSITION	
	REFERENCE ZERO	Z 0000.000	X 25.000	Z 85.000
S	115		S 0100	
				% 115
F	0100.000	% 080	SMAX 1000	
			RANGE 1	



When pressing the two-color key, the CNC shows the special screen of the TC mode.

15:28:42		P000002		
M0 (MSG " " ) (IF P102 EQ 1 GOTO N10) (IF P101 EQ 0 RET) M3 (RET) N10 M4 (RET)		G01 G18  M41  PARTC : 000000 CYTIME : 00:00:00:00 TIMER: : 000000:00:00		
COMMAND	ACTUAL	TO GO	FOLLOWING ERROR	
X 00020.000	X 00020.000	X 00000.000	X 00000.000	
Z 00000.000	Z 00000.000	Z 00000.000	Z 00000.000	
THEORETICAL	RPM	M/MIN		
S	0.0000	S	0.0000	S 0.0000

During execution, both screens show (in the top center window) the number of the program and the number of the cycle being executed. However, when detecting an RPT or GOTO instruction, the cycle number will disappear.



Once the operation or part has been selected, it may be executed as often as desired; to do that, once the execution has finished, pressed the [START] again.



To interrupt the execution, press [STOP]. Once the execution has been interrupted, a tool change may be done. See ["7.4.1 Tool inspection"](#) on page 178.



While executing an operation or a part, the [GRAPHICS] key may be pressed to access the graphics display mode.

7.

EXECUTION AND SIMULATION  
Execution mode

FAGOR

CNC 8055  
CNC 8055i

.TC- OPTION  
(SOFT: V16.1X)

## 7.4.1 Tool inspection

# 7.

EXECUTION AND SIMULATION  
Execution mode



The PLC mark M5050 "TOOLINSP" determines when tool inspection is enabled.

TOOLINSP=0 Tool inspection is possible after pressing [STOP].

TOOLINSP=1 Pressing [STOP] interrupts the execution of the program. To move the axes and do a tool inspection, press the [T] key once the execution of the program has been interrupted.

Once tool inspection has been selected, it is possible:

- To move the axes to the tool change point.
- To select another tool.
- To modify the tool values.
- To resume program execution.

### **To move the axes to the tool change point.**

To move the axes with the handwheels or the jog keypad to the point where the tool will be changed.

### **To select another tool.**

The standard screen of the TC mode must be selected in order to be able to make a tool change.

Press the [T] key. The CNC highlights the tool number.



Type in the number of the tool to be selected and press [START] so the CNC selects the new tool. The CNC will manage the tool change.

### **Modifying the tool values (dimensions and geometry).**



Press the key associated with tool calibration. The CNC shows the screen for tool calibration.

It is possible to modify the dimensions of the tool (offsets I, K to compensate for wear) or the values for tool geometry.

Press the [ESC] key to exit this screen and go back to the previous one (still in tool inspection).

### **Resuming program execution.**



Press the [START] key to resume program execution. The CNC will reposition the tool by moving it to the point where tool inspection began.

There may be 2 cases; either only one axis moved or several did.

- Only one axis moved.  
The CNC repositions it and resumes the execution.



CNC 8055  
CNC 8055i

.TC- OPTION  
(SOFT: V16.1X)

- Both axes moved.

The CNC will show a window with the following options to choose the order the axes will be repositioned.

PLANE	The axes of the X-Y plane move at the same time.
Z-X	When moving the axes of the plane, the Z axis moves first and then the X.
X-Z	When moving the axes of the plane, the X axis moves first and then the Z.

# 7.

## EXECUTION AND SIMULATION Execution mode



CNC 8055  
CNC 8055i

.TC- OPTION  
(SOFT: V16.1X)

## 7.5 Graphic representation



When pressing the [GRAPHICS] key, the CNC shows the graphics screen of the T model. To quit the graphics mode, press either [GRAPHICS] or [ESC].

During simulation, the top center window shows the number of the program and the number of the cycle being executed. However, when detecting an RPT or GOTO instruction, the cycle number will disappear.

The operation manual, T model, "Graphics" section of the "Execution / Simulation" chapter describes how to use the graphics display. However, here is a brief description of the softkeys.

### Type of graphic

The graphics may be "X-Z", "X-C", "Z-C", "Solid X-Z", "Solid X-C" or "Solid Z-C".

The "X-Z", "X-C" and "Z-C" graphics are line graphics that describe the tool tip movement with color lines.

The graphics start from a three-dimensional block and the tool removes material during the execution or simulation showing the shape of the resulting part.

### Display area

XZ, XC, ZC                      They draw the part in the selected plane.

SOLID                              It shows a three-dimensional block that will be "machined" as the part-program is being run.

With this option it is possible to re-define the display area by defining the maximum and minimum values for each axis.

Use the [↑][↓] keys to select the maximum and minimum values. Once all the data has been defined, press [ENTER].

When selecting a new display area, the CNC clears the screen and shows the axes or the part unmachined.



The display area cannot be changed while executing or simulating the part. If it is, interrupt the execution or simulation by pressing the [STOP] key.

### Zoom

With this option, it is possible to enlarge or reduce the graphics display area.

It shows a window superimposed on the current graphics and another one over the drawing at the lower right-hand side of the screen. These new windows indicate the new display area being selected.

Use the [←][→][↑][↓] keys to move the window around, the softkeys "ZOOM+" "ZOOM-" to enlarge or shrink its size and press [ENTER] for those new values to be assumed.

# 7.

EXECUTION AND SIMULATION  
Graphic representation



CNC 8055  
CNC 8055i

.TC- OPTION  
(SOFT: V16.1X)



Every time a new display area is selected, the CNC keeps the current graphic representation. It does not delete it.



When pressing [START] to resume or re-start the execution or simulation, it deletes the current graphic representation and starts a new one with the new values.



The zoom function cannot be used while executing or simulating the part. If it is, interrupt the execution or simulation by pressing the [STOP] key.

## Graphic parameters

- Simulation speed.  
Select on the top right side of the screen the percentage of simulation speed to be applied.  
Use the [←][→] keys to select the percentage and press [ENTER] for the CNC to assume that value.
- Tool path colors.  
It only makes sense in line graphics (not in solid ones). It lets you choose the colors to represent rapid traverse, the tool path without compensation, the tool path with compensation and threading.  
Use the [↑][↓] keys to select, on the right side of the screen, the type of path and use the [←][→] keys to select the color to be applied.  
Press [ENTER] for the CNC to assume those values.
- Colors of solid.  
It only makes sense in solid graphics (not in line graphics). It lets you use the colors to represent the cutter, the part, the axes and the clamps.  
Use the [←][→] keys to select, on the right side of the screen, the type of path and use the [↑][↓] keys to select the color to be applied.  
Press [ENTER] for the CNC to assume those values.

## Clear screen

When selecting this option, the CNC clears the screen and shows the axes or the part unmachined.



The screen cannot be cleared while executing or simulating the part. If it is, interrupt the simulation by pressing the [STOP] key.

## Starting graphic simulation



Once the type of graphics, the display area, the graphic parameters, etc have been selected, press the [START] key to start graphic simulation.

During graphic simulation, the CNC takes into account the simulation speed and the position of the feedrate override switch (FEED 0%-120%).

When selecting a new simulation speed, the CNC applies 100% of it regardless of the position of the switch. Once the switch is turned, the CNC begins to apply the selected %.

To interrupt the simulation, press [STOP].

To quit the simulation mode, press either [GRAPHICS] or [ESC].



# 7.

EXECUTION AND SIMULATION  
Graphic representation



CNC 8055  
CNC 8055i

-TC- OPTION  
(SOFT: V16.1X)

## ISO

In the conversational mode of the CNC, it is possible to generate an ISO-coded program with some basic G functions as well as M and T functions from an operation (cycle) or on a part-program.

To enable this feature, set general machine parameter ISOSIMUL (P183) with a value other than zero. This parameter identifies the number of the ISO program generated in user RAM memory.

The program generated from the conversational program is an ISO-coded program created in RAM memory. This program may be later edited, copied or executed at the CNC itself.

To generate the ISO program, use the simulation in conversational mode through the "GRAPHICS" key. This can be done in a whole program on the PPROG screen or in any of the particular TC or MC cycles.

Once inside the graphic simulation screen, the ISO generation maybe selected using the <ISO> softkey. Then, pressing [CYCLE START] will generate the program defined by machine parameter ISOSIMUL (that will only contain ISO instructions) while it simulates it graphically.

When generating that program, parametric programming, rounding (G36), tangential entry (G37), tangential output (G38), chamfer (G39) and path tangent to previous path (G8) are resolved and generated only using G1, G2 and G3 blocks.

If the program already exists, it will be deleted without requesting confirmation. If the generated program exceeds the available user memory, the CNC will issue the corresponding error message, but it will keep in memory the portion of the ISO program generated so far.

### Description of the functions used to generate an ISO-coded program:

The ISO-coded program is mainly generated to control axes. It provides information of the moving conditions and indications on feedrate using the following set of functions

- **G functions:** Motion preparatory functions to determe the geometry and work conditions.

Function	Meaning
G2 (G3) G6 X Y I J	In the circular interpolation, the center will be programmed with respect to the origin, not referred to the starting point of the circle.

Rigid tapping cycles G84 (mill) and G86 (lathe) only generate the equivalent ISO block.

- **"F" and "S" functions:** Functions to control the feedrate of the axes and the spindle turning speed.
- **T and D functions:** Tool control functions.

If the T function has an associated subroutine, the blocks of this subroutine are ignored when generating the program set by g.m.p. ISOSIMUL (P183).

- **M function:** Complementary or auxiliary functions.

If the M functions have an associated subroutine, the blocks of this subroutine are ignored when generating the program set by g.m.p. ISOSIMUL (P183).



CNC 8055  
CNC 8055i

.TC- OPTION  
(SOFT: V16.1X)



**7.**



**CNC 8055  
CNC 8055i**

.TC- OPTION  
(SOFT: V16.1X)

