

# CONTENT

Foundation plan	P1
Description	P2
Operation	P3
Service and maintenance	P4
Lubrication and lubricants	P5
Routine maintenance program	P6
Trouble shooting	P7
Threads and feeds indicator	P9
Wiring diagram	P11
Headstock	P12
Headstock gear shift	P15
Gear box	P17
Gear box gear shift	P19
Apron	P21
Saddle and top-slide	P24
Tailstock	P29
Bed	P32
Gear train	P38
Steady/follow rest and bed micro stop set	P40

# FOUNDATION PLAN

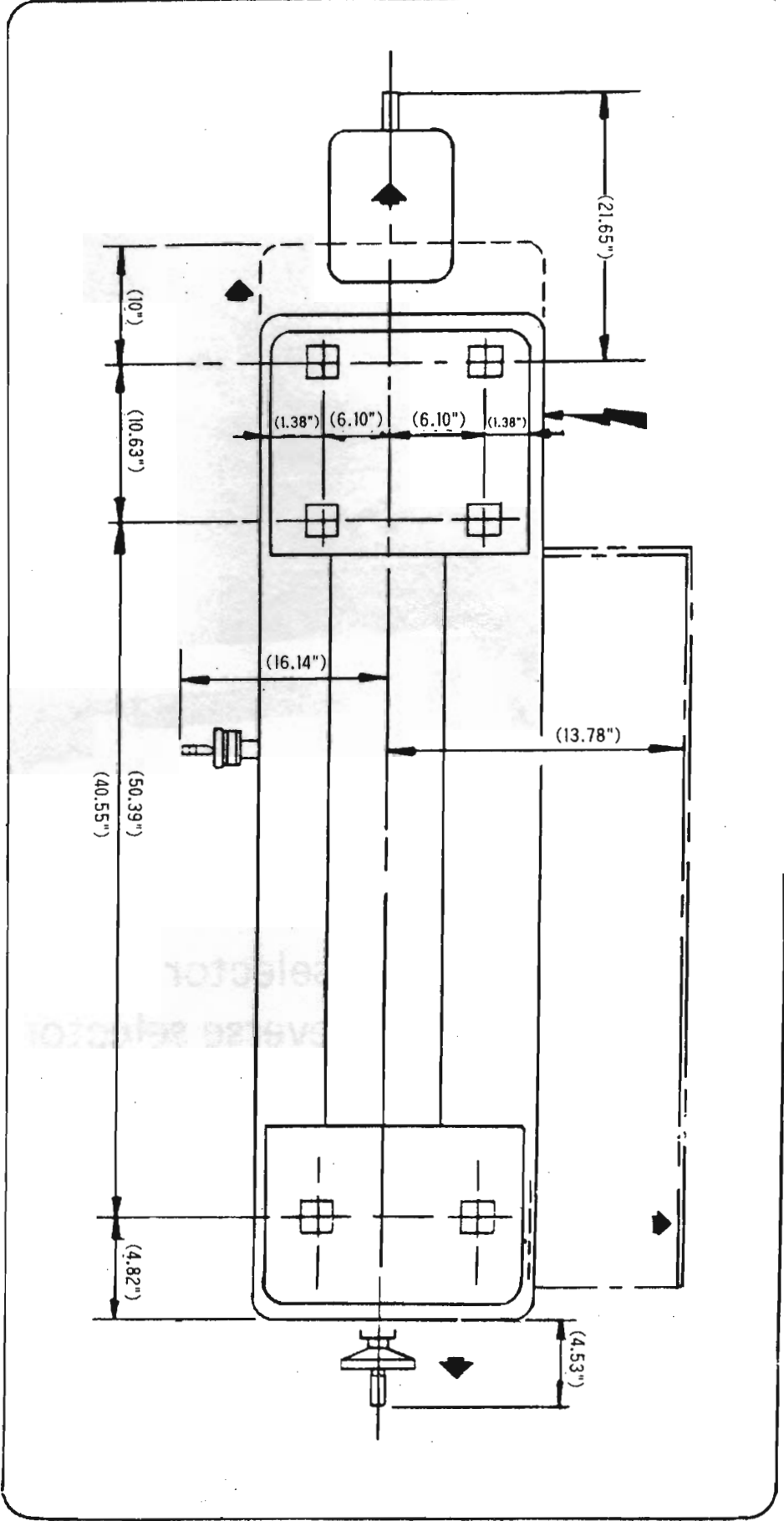

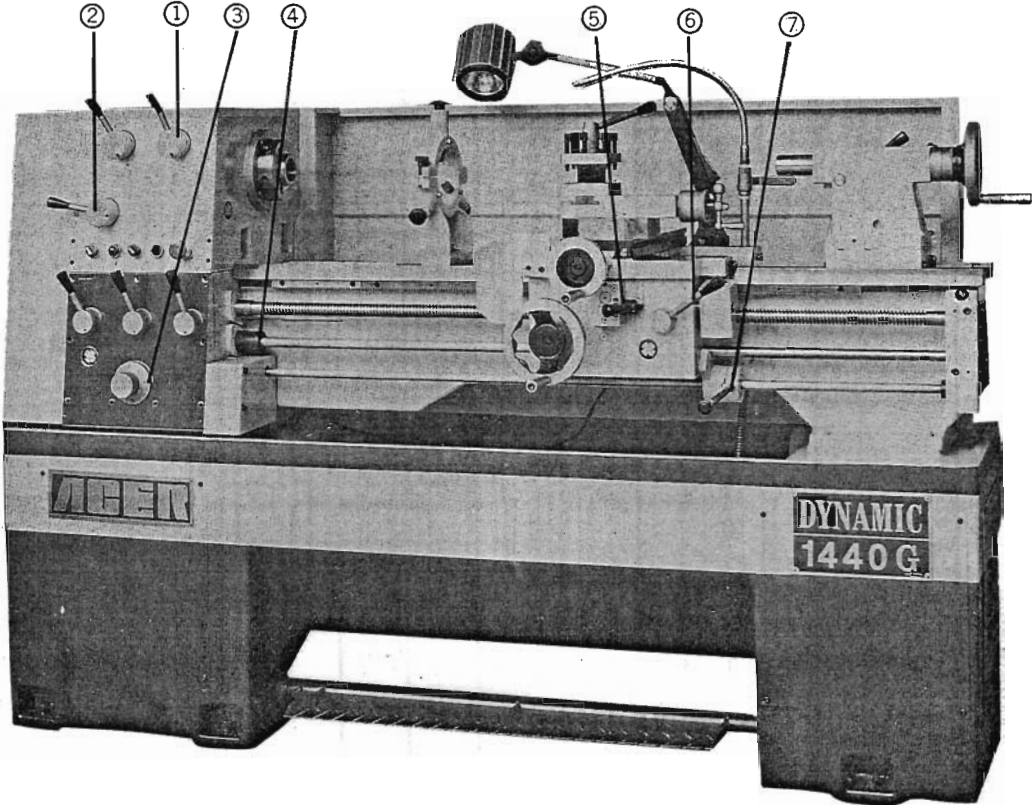

**DESCRIPTION:**

1. Spindle speed selector.
2. Forward and reverse selector.
3. Threads and feed selector.
4. Safety equipment.
5. Cross or longitudinal feed selector.
6. Threading clutch lever.
7. Starting lever.

# OPERATION CHUCKS AND CHUCK MOUNTING

**WARNING: USE ONLY HIGH-SPEED CHUCKS WITH THESE MACHINES.**

When fitting chucks or faceplates, first ensure that spindle and chuck tapers are scrupulously clean that all comes lock in the correct positions; see Fig. 9, It may be necessary to re-set the camlock studs (A) when mounting a new chuck. To do this, remove the cap-head locking screws (B) and set each stud so that the scribed ring (C) is flush with the rear face of the chuck-with the slot-lining up with the locking screw hole see Fig. 8.

Now mount the chuck or faceplate on the spindle nose and tighten the six cams in turn. When fully tightened, the cam lock line on each cam should be between the V marks on the spindle nose.

If any of the cams do not tighten fully within these limit marks, remove the chuck or faceplate and re-adjust the stud as indicated in the illustration. Fit and tighten the locking screw (B) at each stud before remounting the chuck for work. A reference mark should be made on each correctly fitted chuck or faceplate to coincide with the reference mark scribed on the spindle nose.

This will assist subsequent remounting. Do NOT INTERCHANGE CHUCKS OR FACE PLATES BETWEEN LATHES WITHOUT CHECKING FOR CORRECT CAM LOCKING.

**IMPORTANT:** Take careful note of speed limitations when using faceplates; 12in. or 10in. faceplates should not be run at speeds higher than 680 rev/min.

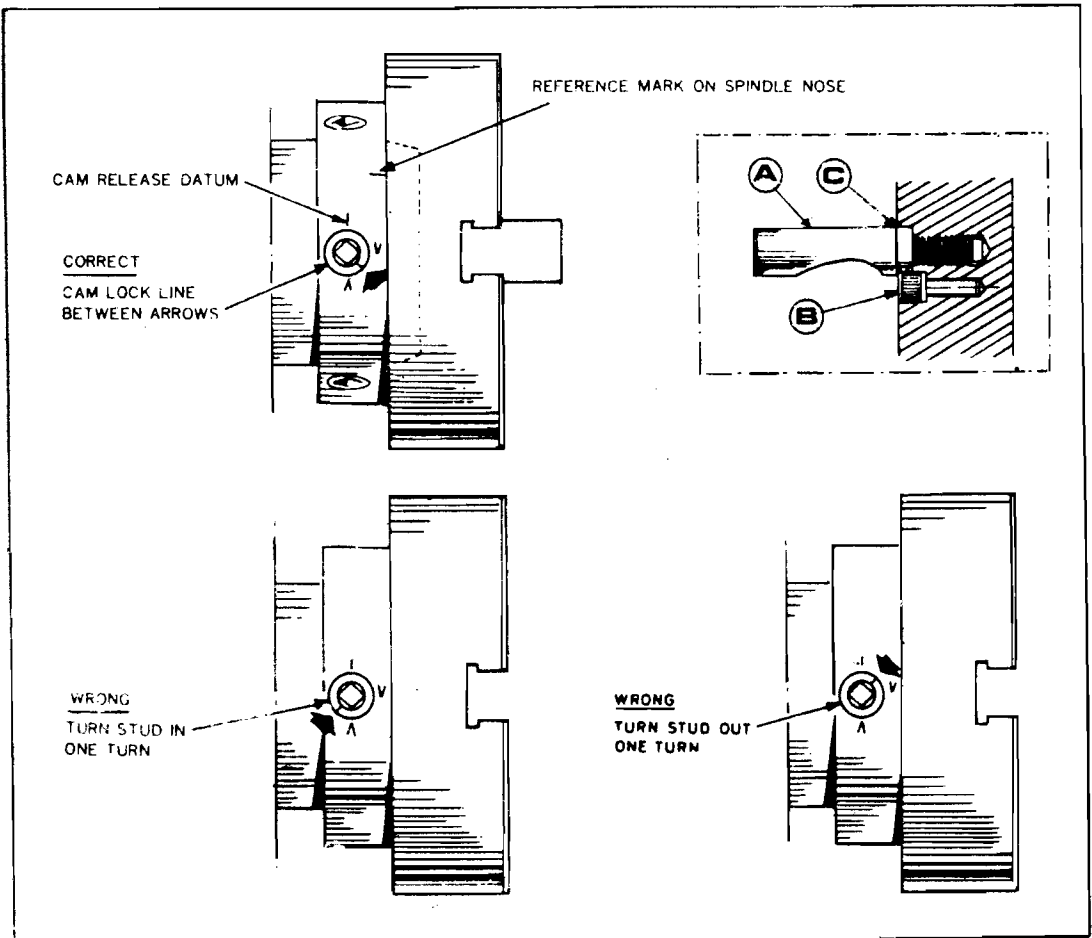



# SERVICE AND MAINTENANCE

## LATHE ALIGNMENT

With the lathe installed & running, we recommend a check on machine alignment before commencing work. Check levelling & machine alignment at regular periods to ensure continued lathe accuracy.

**HEADSTOCK CHECK:** Take a light cut with a keen tool over a 6" (150mm) long and 2" dia. (50mm) steel bar gripped in the chuck but not supported at the free end.

micrometer readings at each end of the turned length (at A & B of Fig.20) should be the same.

To correct a difference in readings, slacken the four headstock hold-down screws(J) shown in Fig. 21 and adjust the screws on the rib and rear beneath the headstock.

Tighten all screws after adjustment and repeat the test-cut/micrometer-reading sequence until micrometer readings are identical, i. e.

**TAILSTOCK CHECK:** Using a 12" (305mm) ground steel bar fitted between headstock and tailstock centers, check the alignment by fitting a dial-test indicator to the topslide and traversing the center line of the bar (lower sketch Fig.20) To correct error release the tailstock clamp lever and adjust the set over screws provided. Continue with checking and correction until the alignment is perfect.

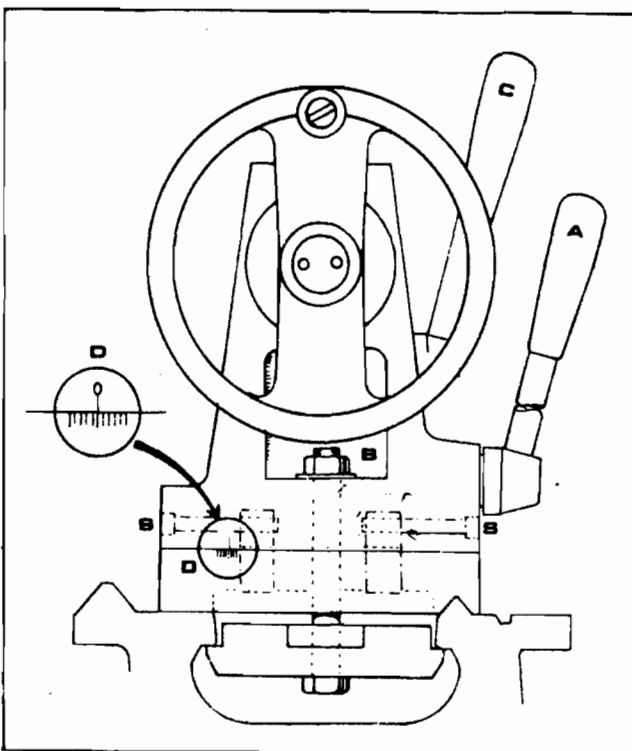
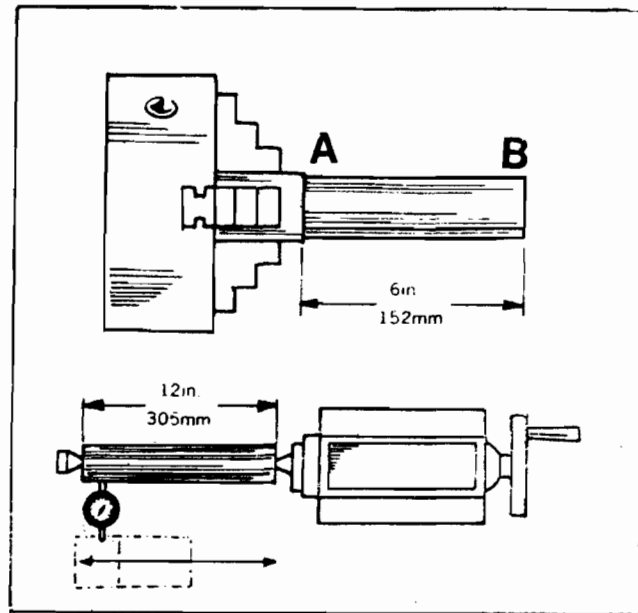

## TAILSTOCK

Can be freed for movement along the bed by unlocking the clamp lever (A).

Additional clamping may be obtained by tightening the large nut (B) located in a recess below the handwheel.

Release this clamping nut before attempting to move the tailstock and when in the need for extra clamping.

The tailstock barrel is locked by lever (C), see Fig. 18

The tailstock can be set-over for production of shallow tapers or for re-alignment.

Release the clamping lever and adjust screw (S) at each side of the base (Fig.19) to move tailstock laterally across the base, An indication of the set-over is given by the datum mark (D) at the tailstock end face, as shown in Fig. 19, Apply clamp lever after adjustment of set-over.

# LUBRICATION AND LUBRICANT

It is most important to lubricate lathe before operation. The operator should be responsible for the proper lubrication of the lathe. The grade and the quality of lubricants are given on the following oil lubrication chart. The instructions on this chart are essential to the proper oiling of the internal parts of the lathe. Oil levels should be strictly observed, for it is of primary importance for proper operation and long life that the oil bath for the headstock which always be completely filled.

Note: 1. Headstock and gear box are lubricated by and automatic oil system.

2. Isolate the machine before removing any cover and making adjustment.

3. For 1440G, apron is oil bathed and the saddle ways are lubricated by pumping oil through the oil nipples on top of the saddle.

No.	Lubricating Point	Oiling Method	Viscosity S.U.S.100F	Oil Recommended	Oil Replenishment or Filling
1	headstock feed gearbox	to open upper cap on headstock	160	SHELL(TELLUS)27 ESSO(TERESSO)43	two times a year (replenishment)
2	compound slides oiler(nipple)	by gun oiler	320	SHELL(TONNA)33 ESSO(TERESSO)52	once a day (filling)
3	apron & carriage	pull the pump- ing handle at apron bottom	320	SHELL(TONNA)33 ESSO(TERESSO)52	once a day (filling)
4	tailstock nipple	by gun oiler	320	SHELL(TONNA)33 ESSO(TERESSO)52	once a day (filling)
5	change gears nipple	by gun oiler	320	SHELL(TONNA)33 ESSO(TERESSO)52	once a day (filling)
6	leadscrew nipple	by gun oiler	320	SHELL(TONNA)33 ESSO(TERESSO)52	once a day (filling)
7	feed rod nipple	by gun oiler	320	SHELL(TONNA)33 ESSO(TERESSO)52	once a day (filling)
8	bedways	by gun oiler	320	SHELL(TONNA)33 ESSO(TERESSO)52	once a day (filling)

# ROUTINE MAINTENANCE PROGRAM

A regular program of preventative maintenance is recommended to keep the machine in good working order. This will reduce service calls and cost to you.

## Weekly Check

area	attachment	item check	method of check	permissible condition	action if required
headstock	bearings and gears	lubrication	visual	level indicated on oil sight	top use replace oil annually
tailstock		lubrication		lubricate weekly	see lubrication checks
topslide		lubrication		lubricate weekly	see lubrication checks
coolant		level	visual	50mm below top of tank	top up see coolant filling

## Half Year Checks

area	attachment	item check	method of check	permissible condition	action if required
headstock	spindle drive belts	tension	tension test tool	see belt tensioning tables	see belt tensioning section
saddle	taper gibs	slideway clearance	dial test indicator	see belt tensioning tables	see belt tensioning section
crossslide	taper gib strip	slideway clearance	dial test indicator	see belt tensioning tables	see gib adjustment section

## Annual Checks

area	attachment	item check	method of check	permissible condition	action if required
headstock	spindle	alignment	test bar	see accuracy chart	re-align by service engineer
tailstock		body setover	test bar and test indicator	see accuracy chart	re-align
		runout	dial test indicator		check by service engineer
		cleaning			see coolant system cleaning

# TROUBLE SHOOTING

## TROUBLE SHOOTING CHART

TROUBLE	PROBABLE CAUSE	CORRECTION
Vibration	<p>Loose leveling screws</p> <p>Torn or mismatched vee belts</p> <p>Work or chuck out of balance operating at high spindle speed motor out of balance</p>	<p>Set all screws so they bear evenly on leveling plates.</p> <p>Replace vee belts with matched set.</p> <p>Balance chuck or reduce spindle speed</p> <p>Contact local representative of motor manufacturer.</p>
Chatter	<p>Tool bit improperly ground or not on center</p> <p>Tool overhang too great</p> <p>Using improper surface feed</p> <p>Feed rate too higher too low</p> <p>Gibs of cross slide or compound rest loose</p> <p>Spindle bearings worn</p>	<p>Regrind tool bit or adjust tool holder so that area of contact between tool bit and work is decreased. Avoid extreme negative rake angle.</p> <p>Keep point of tool bit as close as possible to tool holder.</p> <p>Reduce or increase spindle speed.</p> <p>Reduce or increase feed.</p> <p>Adjust gibs.</p> <p>Adjust spindle bearings</p>
Chatter (cont'd)	<p>Work improperly supported</p> <p>Vibration</p> <p>Spindle bearing loose</p>	<p>Adjust tailstock center. Use steady rest or follow rest on long slender shafts. Minimize tailstock barrel extension.</p> <p>See "Vibration" trouble above.</p> <p>Adjust spindle bearings</p>

<p>Work not turn straight</p>	<p>Headstock and tailstock centers not aligned Work improperly supported  Bed not level  Tool not on center when using taper attachment</p>	<p>Align tailstock center.  Use steady rest or follow rest. Reduce overhang from chuck.  Reduce bed, using precision level.  Put tool on center.</p>
<p>Work out of round</p>	<p>Work loose between center or centers are excessively worn-work centers out of round Loose headstock spindle bearings</p>	<p>Adjust tailstock center. Regrind centers. Lap work centers.  Adjust headstock spindle bearings</p>

# THREADS AND FEEDS INDICATOR

4 T.P.I

## METRIC

## INCH

## FEED

METRIC						INCH						FEED	
XY			XY			112 NS4E	32 NR1F	9 MR2F	25	0.06 S4E	.002		
25 40	0.25	NS3E	25 40	1.5	MS1F	104 NS4F	28 NT4E	8 MR1F	40	0.08 S1E	.003		
35 40	0.35	NS3E	35 24	1.75	NR1F	96 NS3E	26 NT4F	7 MT4E		0.1 S2F	.004		
30 30	0.4	NS3E	25 40	2.0	MR3E	92 NS2E	24 NT3E	6 1/2 MT4F		0.15 R3E	.006		
30 40	0.45	NS1F	45 24	2.25	NR1F	88 NS1E	23 NT2E	6 MT3E		0.2 R2F	.008		
25 40	0.5	NR3E	25 32	2.5	MR3E	80 NS3F	22 NT1E	5 3/4 MT2E		0.25 T4E	.010		
35 40	0.7	NR3E	25 40	3.0	MR1F	72 NS2F	20 NT3F	5 1/2 MT1E		0.3 T3E	.012		
25 40	0.75	NR1F	35 24	3.5	NT1F	64 NS1F	18 NT2F	5 MT3F		0.4 T2F	.016		
30 30	0.8	NR3E	25 40	4.0	MT3E	56 NR4E	16 NT1F	4 1/2 MT2F		0.5 R2F	.020		
30 40	0.9	NR1F	45 24	4.5	NT1F	52 NR4F	14 MR4E	4 MT1F		0.6 R1F	.024		
25 40	1.0	MS3E	25 32	5.0	MT3E	48 NR3E	13 MR4F			0.7 T4F	.028		
25 32	1.25	MS3E	25 40	6.0	MT1F	46 NR2E	12 MR3E			0.8 T2E	.030		
						44 NR1E	11 1/2 MR2E			0.9 T3F	.035		
						40 NR3F	11 MR1E			1.0 T2F	.040		
						36 NR2F	10 MR3F						

PICTH  
6mm

## METRIC

## INCH



## FEED



METRIC						INCH						FEED	
XY			XY			112 NS4E	32 NR1F	9 MR2F	25	0.06 S4E	.002		
25 40	0.25	NS3E	25 40	1.5	MS1F	104 NS4F	28 NT4E	8 MR1F	40	0.08 S1E	.003		
35 40	0.35	NS3E	35 24	1.75	NR1F	96 NS3E	26 NT4F	7 MT4E		0.1 S2F	.004		
30 30	0.4	NS3E	25 40	2.0	MR3E	92 NS2E	24 NT3E	6 1/2 MT4F		0.15 R3E	.006		
30 40	0.45	NS1F	45 24	2.25	NR1F	88 NS1E	23 NT2E	6 MT3E		0.2 R2F	.008		
25 40	0.5	NR3E	25 32	2.5	MR3E	80 NS3F	22 NT1E	5 3/4 MT2E		0.25 T4E	.010		
35 40	0.7	NR3E	25 40	3.0	MR1F	72 NS2F	20 NT3F	5 1/2 MT1E		0.3 T3E	.012		
25 40	0.75	NR1F	35 24	3.5	NT1F	64 NS1F	18 NT2F	5 MT3F		0.4 T2F	.016		
30 30	0.8	NR3E	25 40	4.0	MT3E	56 NR4E	16 NT1F	4 1/2 MT2F		0.5 R2F	.020		
30 40	0.9	NR1F	45 24	4.5	NT1F	52 NR4F	14 MR4E	4 MT1F		0.6 R1F	.024		
25 40	1.0	MS3E	25 32	5.0	MT3E	48 NR3E	13 MR4F			0.7 T4F	.028		
25 32	1.25	MS3E	25 40	6.0	MT1F	46 NR2E	12 MR3E			0.8 T2E	.030		
						44 NR1E	11 1/2 MR2E			0.9 T3F	.035		
						40 NR3F	11 MR1E			1.0 T2F	.040		
						36 NR2F	10 MR3F						



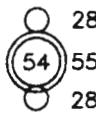

# THREADS AND FEEDS INDICATOR

## D.P. M.P. THREADS INDICATOR ( OPTIONAL )

											
D.P.											
112	NS4E	46	NR2E	18	NT2F	104	NS4F	44	NR1E	16	NT1F
96	NS3E	40	NR2F	14	MT4E	92	NS2E	36	NR2F	13	MT4F
88	NS1E	32	NR1F	12	MT3E	80	NS3F	28	NT4E	11½	MT2E
72	NS2F	26	NT4F	11	MT1E	64	NS1F	24	NT3E	10	MT3F
56	NR4E	23	NT2E	9	MT2F	52	NR4F	22	NT1E	8	MT1F
48	NR3E	20	NT3F								

											
M.P.											
X	Y	mod.		X	Y	mod.		X	Y	mod.	
25	40	0.25	NR3E	25	40	1	MR3E	35	40	0.35	NR3E
30	30	0.4	NR3E	25	32	1.25	MR3E	30	40	0.45	NR1F
25	40	0.5	MS3E	35	24	1.75	NT1F	25	40	0.7	MS3E
35	40	0.7	MS3E	25	40	2	MT3E	25	40	0.75	MS1F
25	40	0.75	MS1F	45	24	2.25	NT1F	30	30	0.8	NT3E
30	30	0.8	NT3E	25	32	2.5	MT3E	30	40	0.9	NT1F
30	40	0.9	NT1F								

PITCH			WORM	
0.5	1.25	2.5	20T	
4.0	5.0			
0.75	1.0	1.5	21T	
1.75	2.0	3.0		
3.5	6.0	7.0		

METRIC

INDICATOR TABLE					
T. P. I.	SCALE	T. P. I.	SCALE	T. P. I.	SCALE
4	1-4	12	1-4	38	$\frac{13}{24}$
4	$\frac{1}{2}$	13	1	40	1-8
4	$\frac{3}{4}$	14	$\frac{13}{24}$	44	1-4
5	1	16	1-8	48	1-8
5	$\frac{1}{2}$	18	$\frac{13}{24}$	52	1-4
6	$\frac{13}{24}$	19	1	56	1-8
6	$\frac{1}{2}$	20	1-4	64	1-8
7	1-4	22	$\frac{13}{24}$	72	1-8
8	1-8	24	1-8	76	1-4
9	1	26	$\frac{13}{24}$	80	1-8
9	$\frac{1}{2}$	28	1-4	96	1-8
10	$\frac{13}{24}$	32	1-8	104	1-8
11	1	36	$\frac{13}{24}$	112	1-8

INCH

# WIRING DIAGRAM

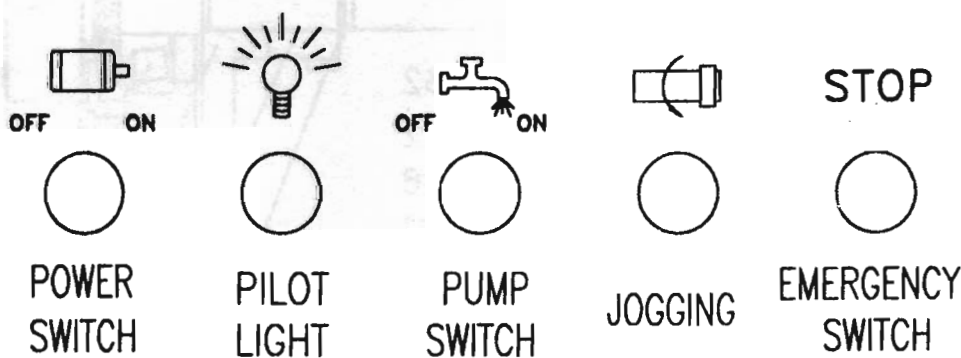
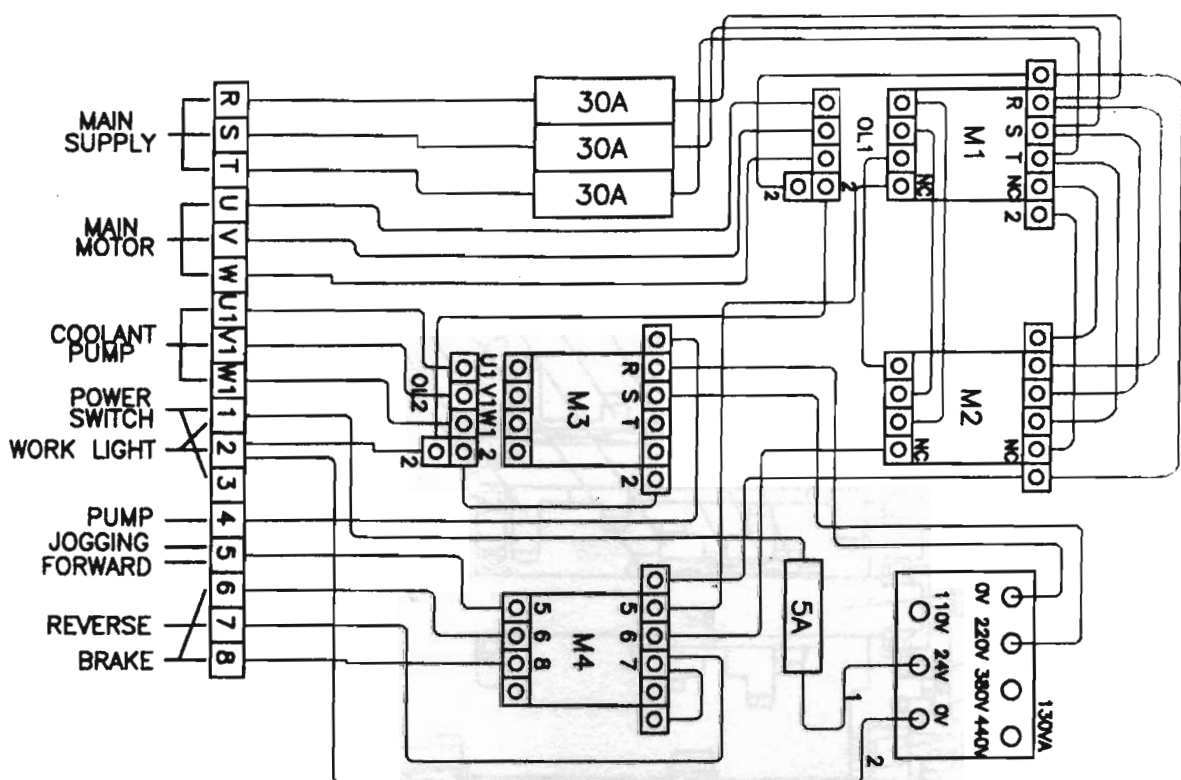

## ELECTRICAL CONTROL

with the exception of the lathe isolator, all electrical controls are fitted onto the front face of the headstock.

1. Press the RED button to stop the main motor and also electrical supply to ancillary services
2. Turn the button on. The indicator lamp A will glow whilst the electricity is supplied.
3. Coolant pump ON/OFF push buttons.
4. Press the GREEN button to start the main drive motor and the indicator lamp glows whilst the motor is running.
5. Emergency stop reset button.



# HEADSTOCK

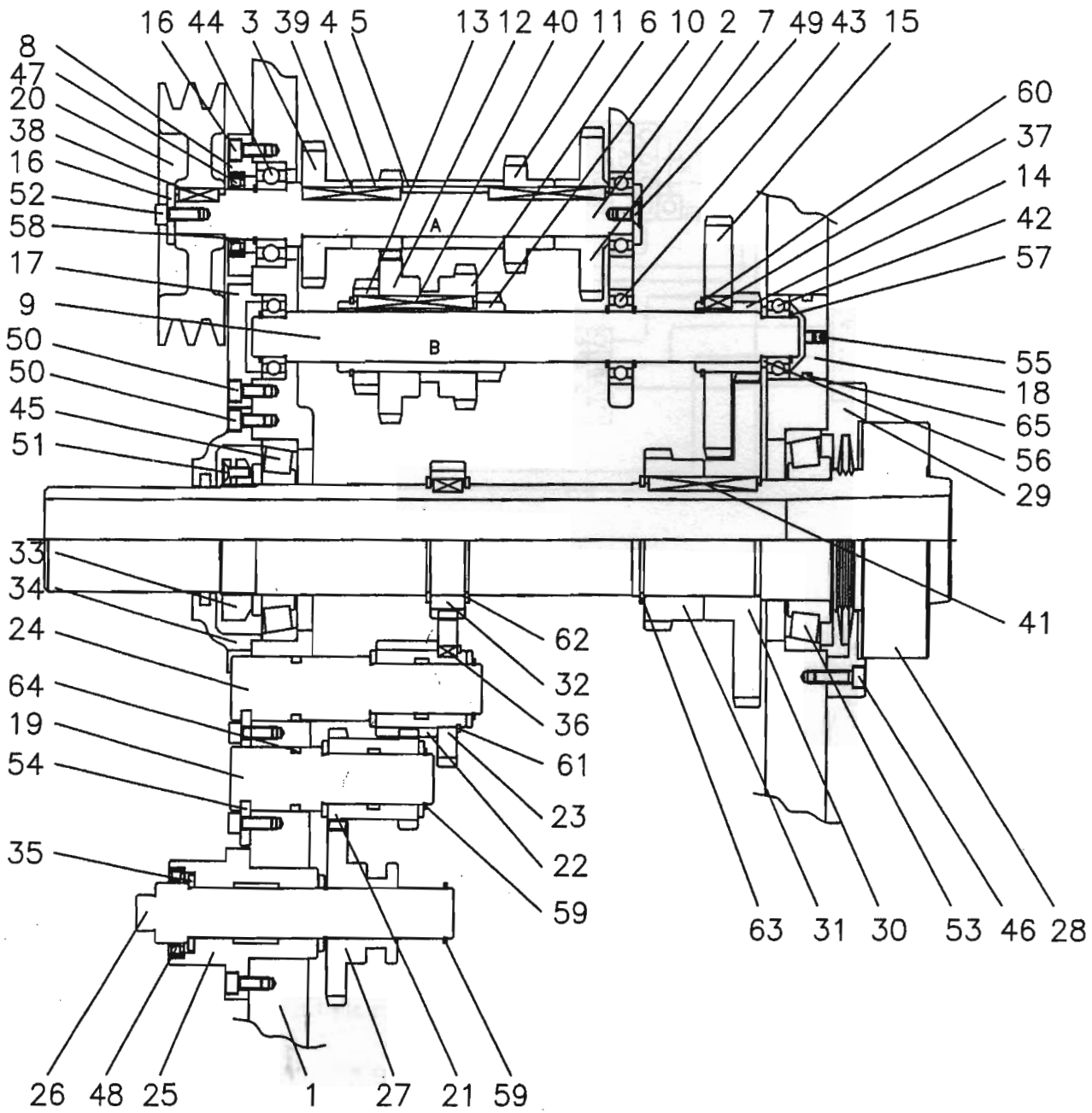



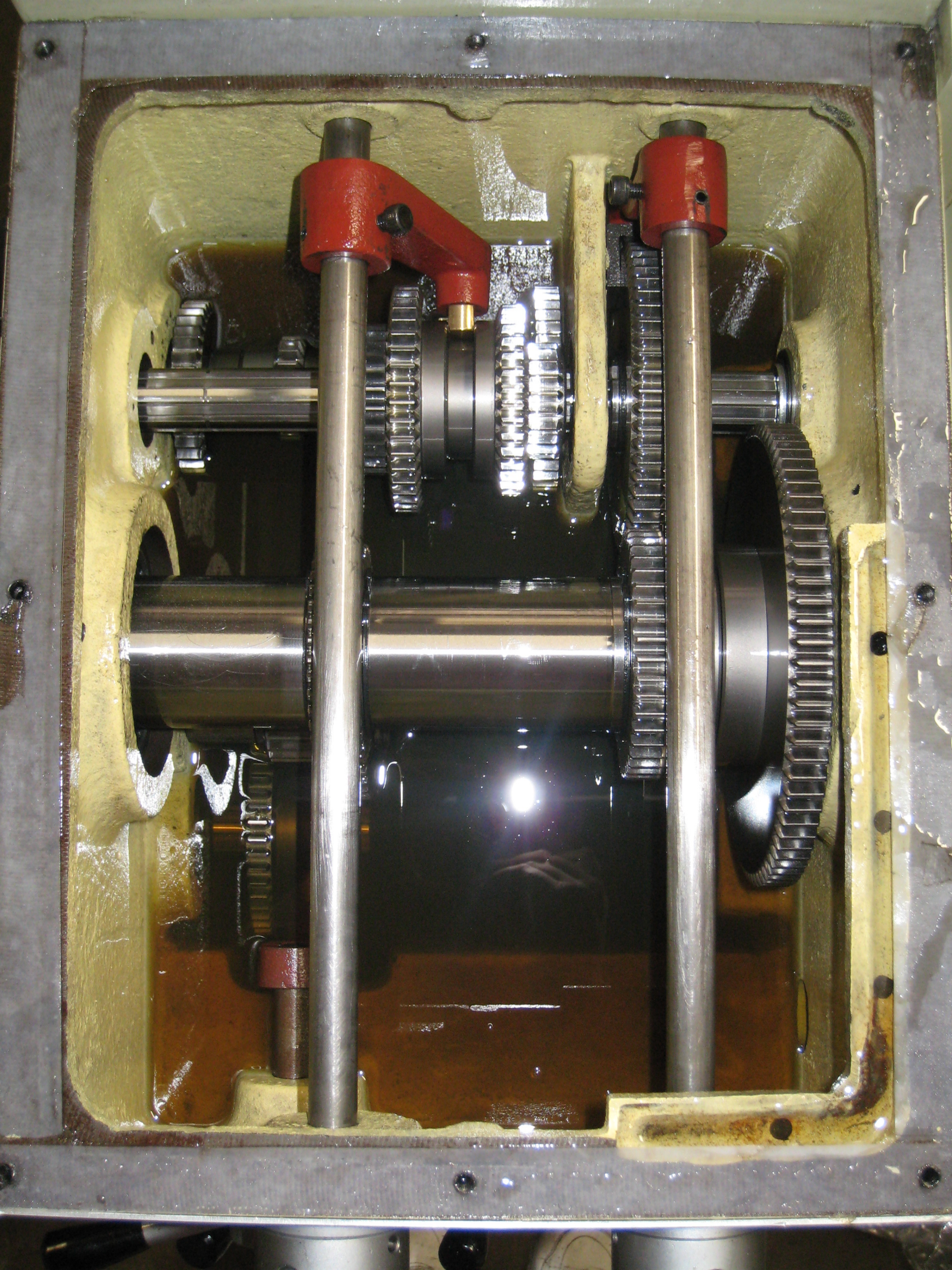



# HEADSTOCK

ITEM NO.	DESCRIPTION	PART NO.	NO.OFF	REMARK
1	CASTING	5101	1	
2	A SHAFT	7102	1	
3	GEAR	7103	1	
4	GEAR	7104	1	
5	COLLAR	7105	1	
6	GEAR	7106	1	
7	GEAR	7107	1	
8	COVER	7108	1	
9	B SHAFT	7109	1	
10	GEAR	7110	1	
11	GEAR	7111	1	
12	GEAR	7112	1	
13	GEAR	7113	1	
14	GEAR	7114	1	
15	GEAR	7115	1	
16	WASHER	7116	1	
17	COVER	7117	1	
18	PLUG	7118	1	
19	C SHAFT	7119	1	
20	PULLEY	7120	1	
21	GEAR	7121	1	
22	GEAR	7122	1	
23	GEAR	7123	1	
24	D SHAFT	7124	1	
25	KEEP ASSY	7125	1	
26	E SHAFT	7126	1	
27	GEAR	7127	1	
28	SPINDLE	7128	1	
29	COVER	7129	1	
30	GEAR	7130	1	
31	GEAR	7131	1	
32	GEAR	7132	1	
33	NUT	7133	1	
34	COVER	7134	1	
35	COLLAR	7135	6	
36	PARALLEL KEY		5*5*10	1

# HEADSTOCK

ITEM NO.	DESCRIPTION	PART NO.	NO.OFF	REMARK
37	PARALLEL KEY		6*6*15	2
38	PARALLEL KEY		6*6*20	1
39	PARALLEL KEY		6*6*50	2
40	PARALLEL KEY		6*6*60	1
41	PARALLEL KEY		8*7*55	1
42	BEARING		6004	3
43	BEARING		6005	1
44	BEARING		6205	1
45	BEARING		30211	1
46	BEARING		30212	1
47	OIL SEAL		TC24*42*08	1
48	OIL SEAL		TC30*45*08	1
49	SOCKET SCREW		M6*10	1
50	SOCKET SCREW		M6*12	6
51	SOCKET SCREW		M6*16	8
52	SOCKET SCREW		M6*20	1
53	SOCKET SCREW		M6*25	4
54	WASHER	7154		2
55	COLLAR	7155		1
56	WASHER	7156		1
57	CIRCLIP		S20	2
58	CIRCLIP		S24	1
59	CIRCLIP		S25	6
60	CIRCLIP		S35	2
61	CIRCLIP		S38	1
62	CIRCLIP		S55	2
63	CIRCLIP		S56	1
64	"O" RING		P26	2
65	"O" RING		P36	1
66	SET SCREW		M6*6	1

# HEADSTOCK GEAR SHIFT

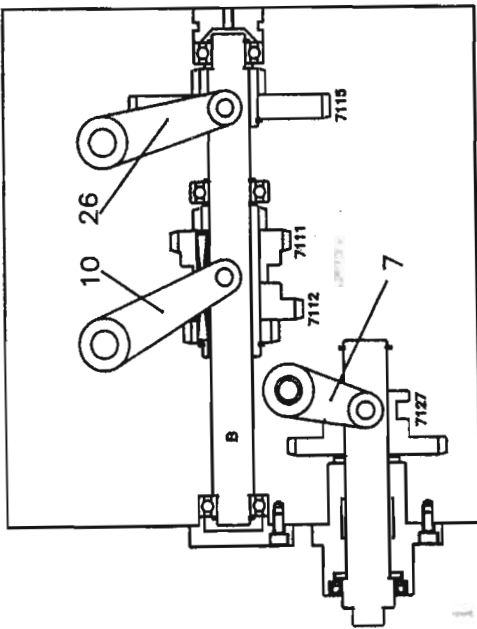
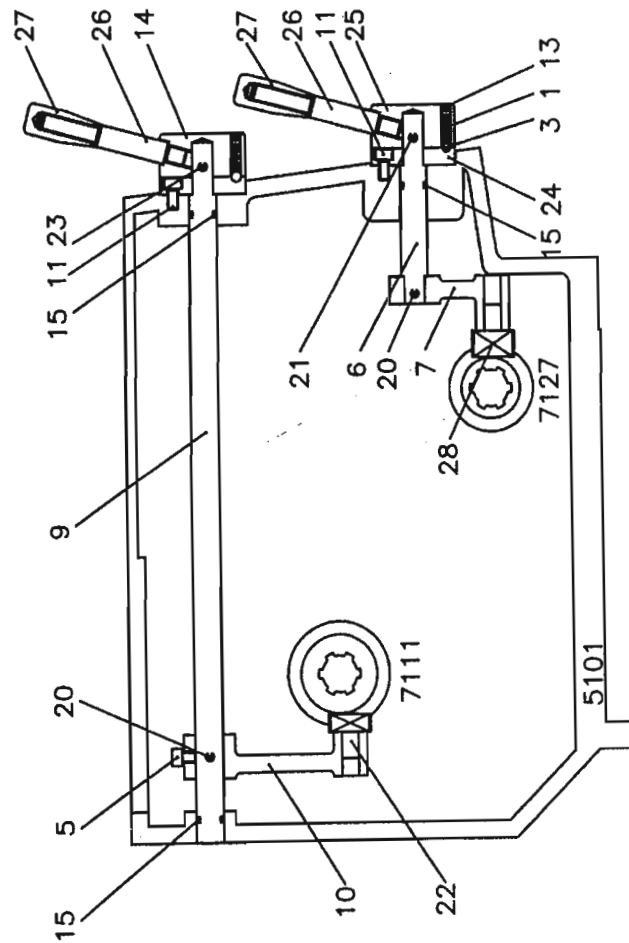
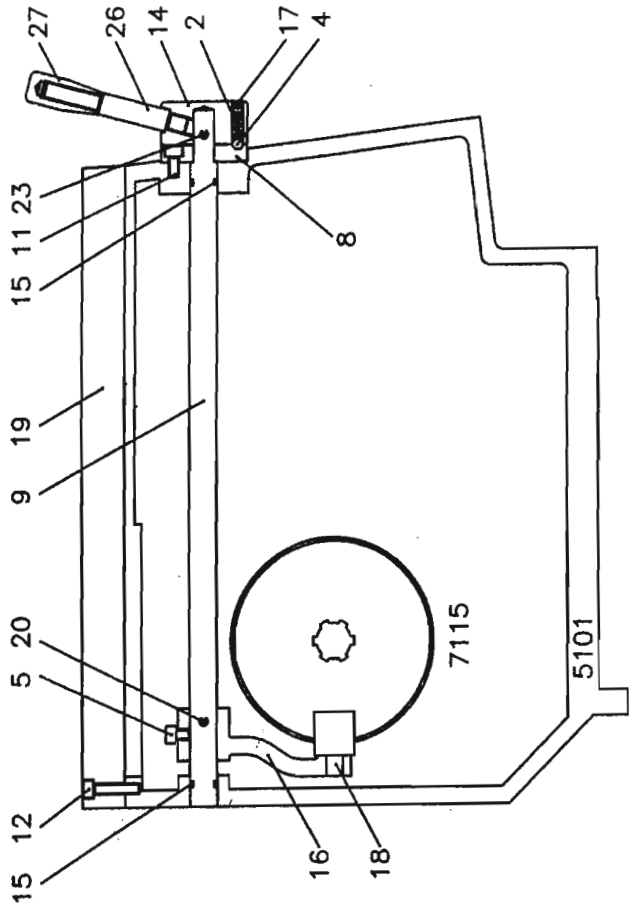

# HEADSTOCK GEAR SHIFT

ITEM NO.	DESCRIPTION	PART NO.	NO.OFF	REMARK
1	COMPRESSION SPRING		ψ4.0*d1.0 1	
2	COMPRESSION SPRING		ψ6.0*d1.0 2	
3	STEEL BALL		3/16" 1	
4	STEEL BALL		1/4" 2	
5	SOCKET SCREW		M6*8 2	
6	SHAFT	7136	1	
7	LEVER	7137	1	
8	WASHER	7138	2	
9	SHAFT	5103	2	
10	LEVER	7140	1	
11	SOCKET SCREW		M6*12 6	
12	SOCKET SCREW		M6*20 8	
13	SET SCREW		M6*6 1	
14	AXLE CAP	7144	2	
15	"O" RING		P12 5	
16	FORK	7146	1	
17	SET SCREW		M8*6 2	
18	FORK	7148	1	
19	COVER	5102	1	
20	SPRING PIN		ψ5*30 3	
21	SPRING PIN		ψ5*40 1	
22	FORK	7152	2	
23	SPRING PIN		ψ5*50 2	
24	WASHER	7244	1	
25	AXLE CAP	7245	1	
26	HANDLE	7246	3	
27	HANDLE	7263	3	
28	FORK	7152-1	1	

# GEAR BOX

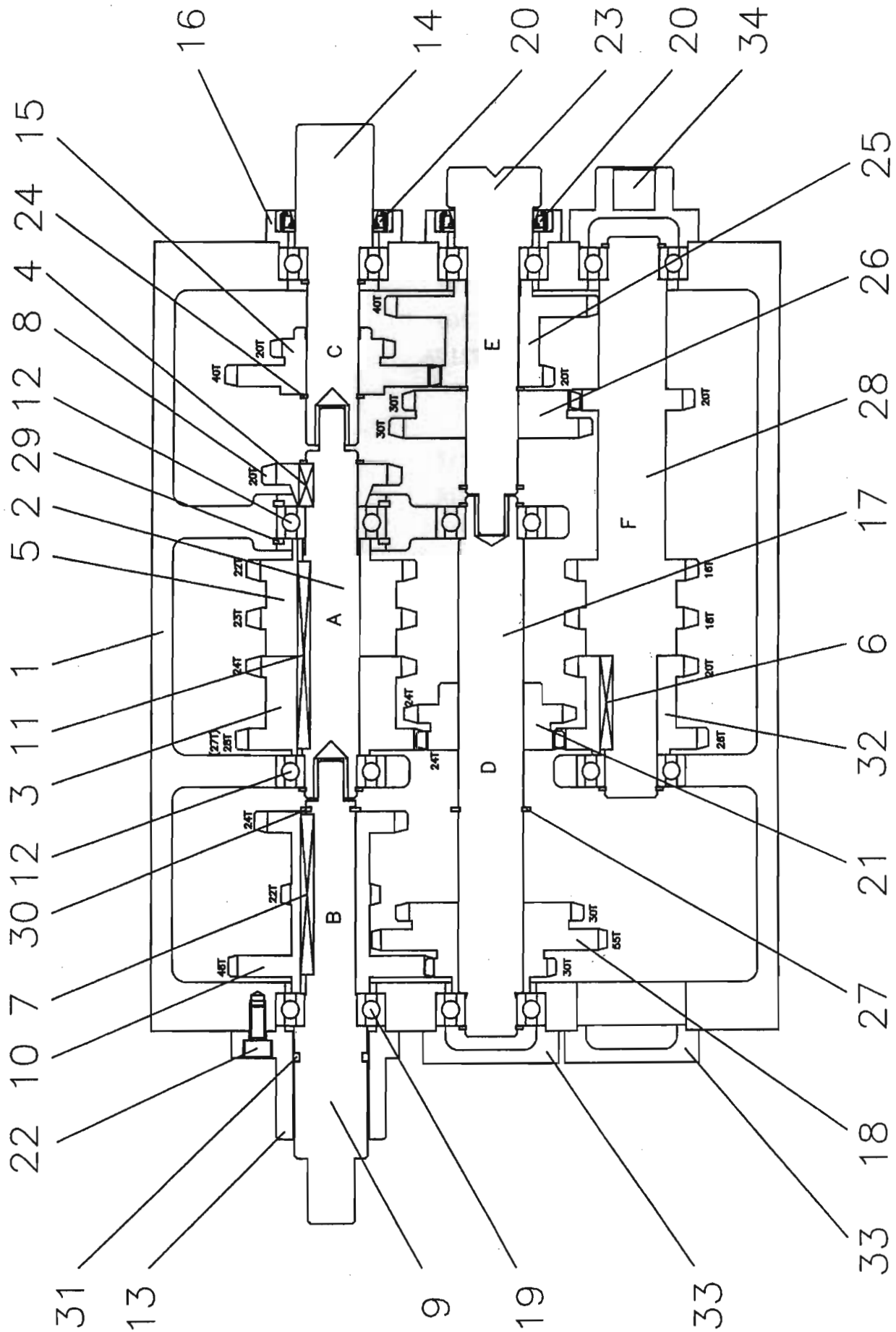



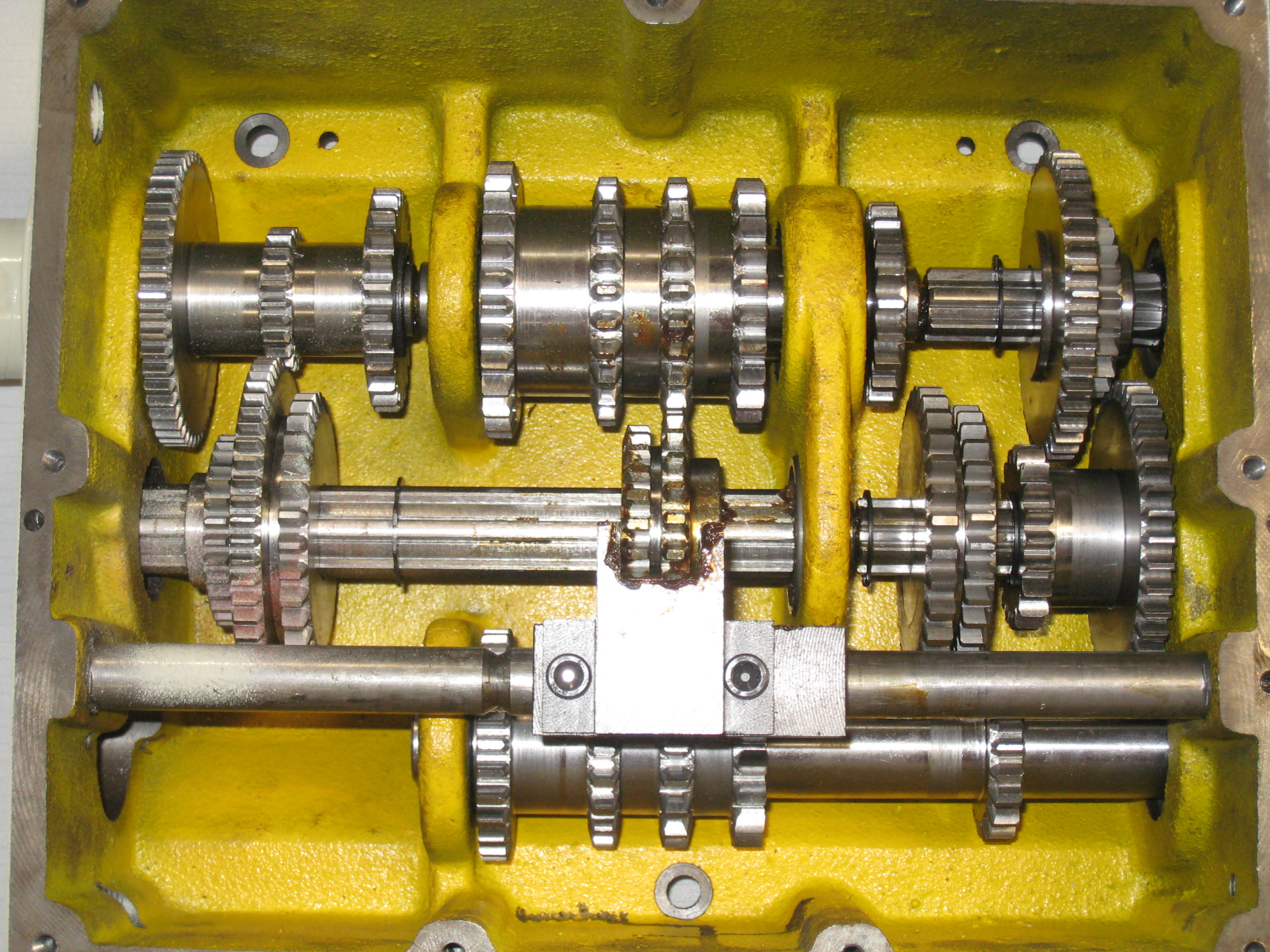



# GEAR BOX

ITEM NO.	DESCRIPTION	PART NO.	NO.OFF	REMARK
1	CASTING	7201	1	
2	A SHAFT	7202	1	
3	GEAR	7203A	1	
4	PARALLEL KEY		5*5*15	1
5	GEAR	7205A		1
6	PARALLEL KEY		5*5*35	1
7	PARALLEL KEY		5*5*60	1
8	GEAR	7208		1
9	B SHAFT	7209		1
10	GEAR	7210A		1
11	PARALLEL KEY		5*5*70	1
12	BEARING		6004	9
13	COVER	7213		1
14	C SHAFT	7214		1
15	GEAR	7215A		1
16	COVER	7216		2
17	D SHAFT	7217		1
18	GEAR	7218A		1
19	COVER	7261		1
20	OIL SEAL		TC30*45*08	2
21	GEAR	7221A		1
22	SOCKET SCREW		M6*16	13
23	E SHAFT	7223		1
24	CIRCLIP		S20	10
25	GEAR	7225A		1
26	GEAR	7226A		1
27	CIRCLIP		S25	1
28	F SHAFT	7228A		1
29	CIRCLIP		R42	2
30	CIRCLIP		E15	1
31	"O" RING		AS-119	1
32	GEAR	7233A		1
33	COVER	7235		1

# GEAR BOX GEAR SHIFT

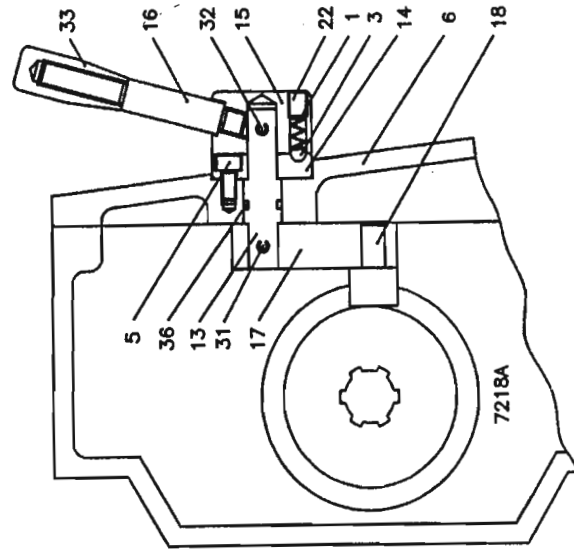
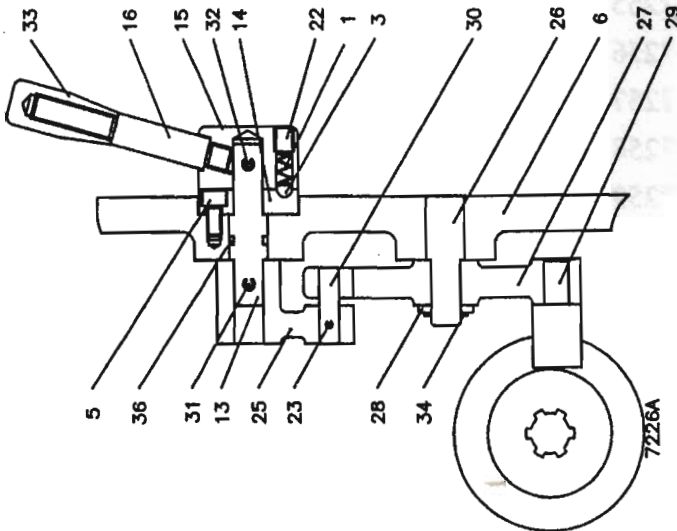
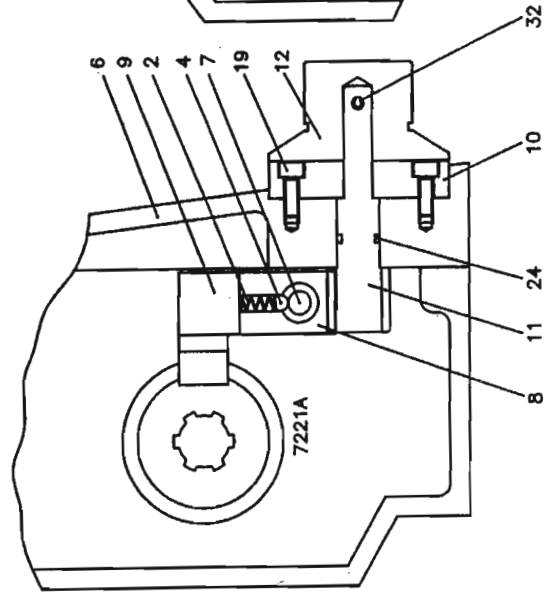
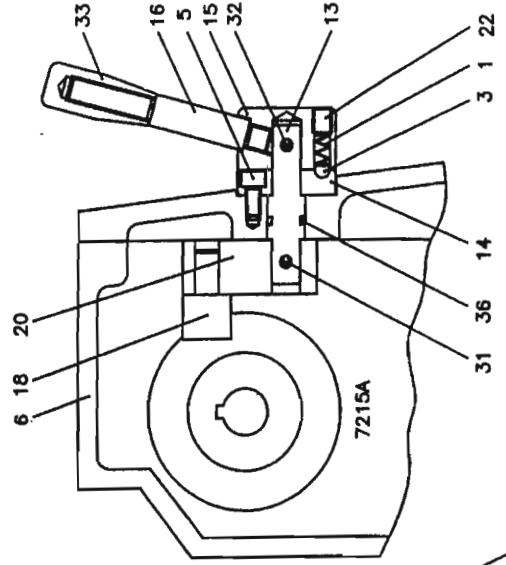
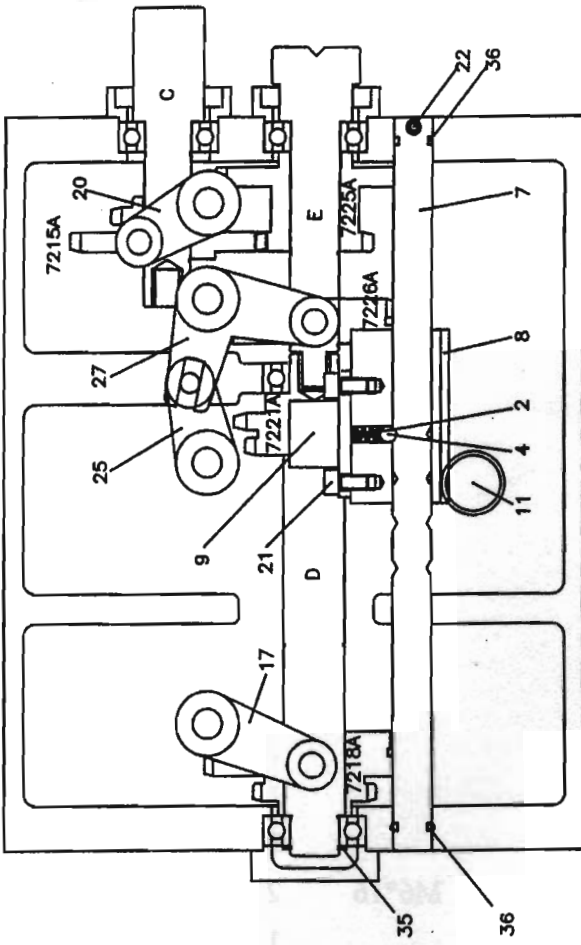



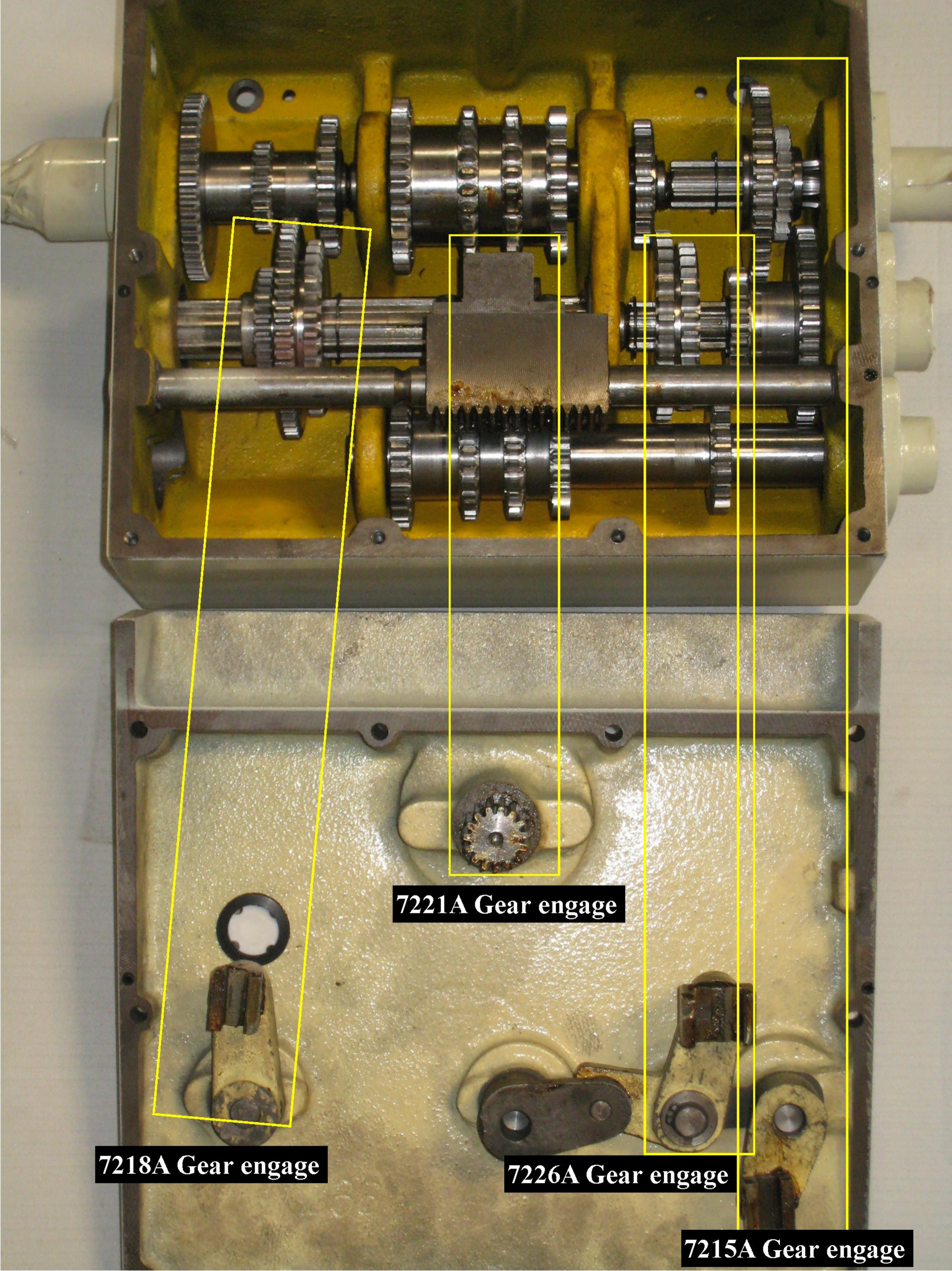

**7221A Gear engage**

**7218A Gear engage**

**7226A Gear engage**

**7215A Gear engage**



# GEAR BOX GEAR SHIFT

ITEM NO.	DESCRIPTION	PART NO.	NO.OFF	REMARK
1	COMPRESSION SPRING		ψ4.0*d1.0 3	
2	COMPRESSION SPING		ψ6.0*d1.0 1	
3	STEEL BALL		3/16" 3	
4	STEEL BALL		1/4" 1	
5	SOCKET SCREW		M6*12 8	
6	COVER	7236	1	
7	SHAFT	7237	1	
8	ROCK	7238	1	
9	FORK	7239	1	
10	WASHER	7240	1	
11	PINION	7241	1	
12	AXLE CAP	7242	1	
13	SHAFT	7243	3	
14	WASHER	7244	3	
15	AXLE CAP	7245	3	
16	HANDLE	7246	3	
17	LEVER	7247	1	
18	FORK	7248	2	
19	SOCKET SCREW		M6*16 2	
20	LEVER	7250	1	22L
21	"O" RING		P12 5	
22	SET SCREW		M6*6 4	
23	SPRING PIN		ψ3*20 1	
24	"O" RING		P14 1	
25	LEVER	7255	1	33L
26	SHAFT	7256	1	
27	LEVER	7257	1	
28	COLLAR	7258	1	
29	FORK	7259	1	
30	PIN	7260	1	
31	SPRING PIN		ψ5*30 3	
32	SPRING PIN		ψ5*40 4	
33	HANDLE	7263	3	
34	CIRCLIP		S12 1	

# APRON

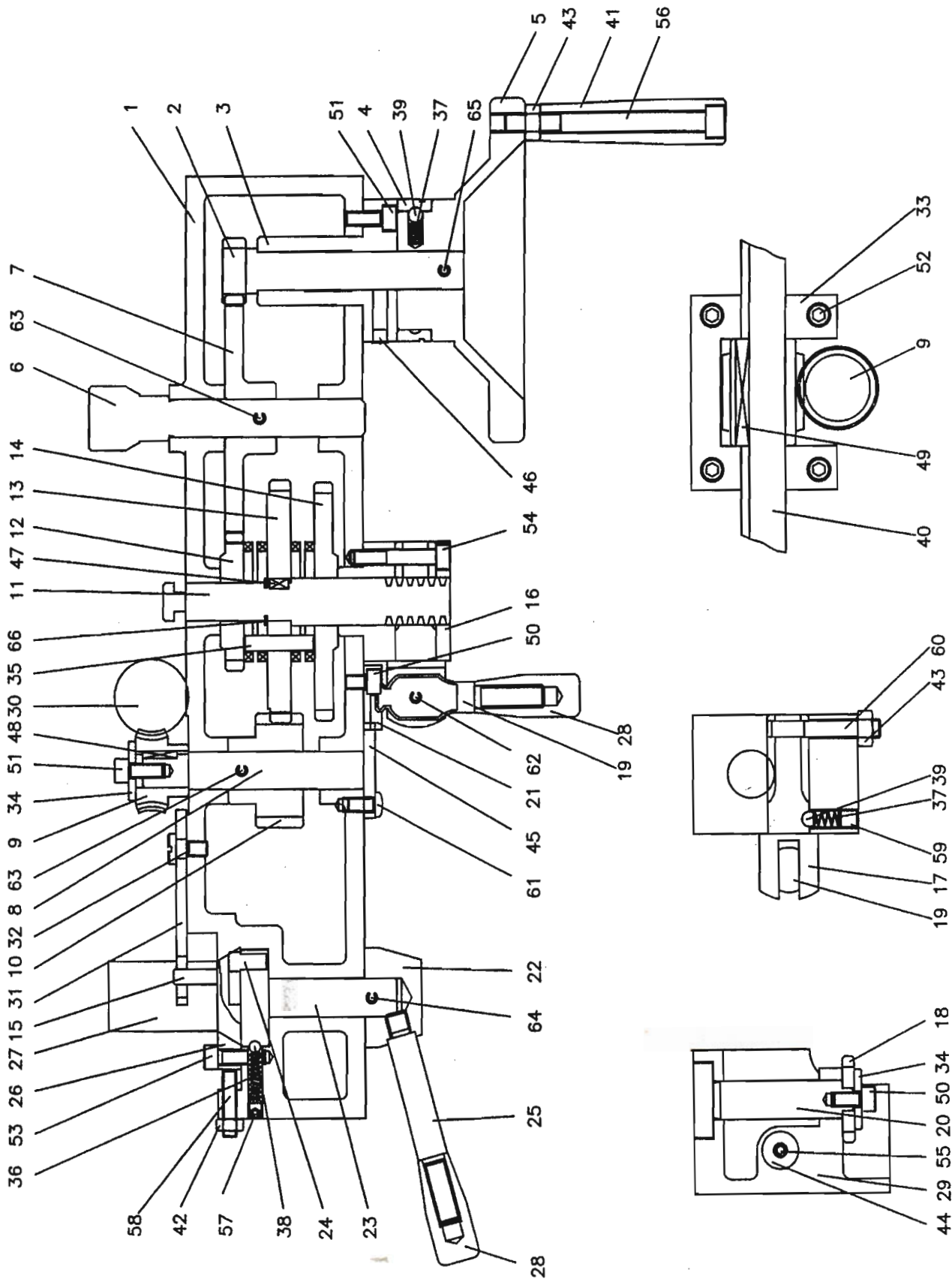











# APRON

ITEM NO.	DESCRIPTION	PART NO.	NO.OFF	REMARK
1	CASTING	7301	1	
2	GEAR	7302	1	
3	BUSH	7303	1	
4	DIAL	7304	1	
5	HAND WHEEL	7305	1	
6	PINION	7306	1	
7	GEAR	7307	1	
8	SHAFT	7308	1	
9	WORM GEAR	7309	1	
10	GEAR	7310	1	
11	GEAR	7311	1	
12	GEAR	7312	1	
13	GEAR	7313	1	
14	GEAR	7314	1	
15	PIN	7315	1	
16	KEEP ASSY	7316	1	
17	SHAFT	7317	1	
18	WORM GEAR	7318	1	
19	HANDLE	7319	1	
20	INDICATOR SHAFT	7320	1	
21	PLATE	7321	1	
22	KEEP ASSY	7322	1	
23	SHAFT	7323	1	
24	PIN	7324	2	
25	HANDLE	7325	1	7514
26	GIB	7326	1	
27	HALF-NUT	7327	1	
28	HANDLE	7263	2	3/18"-16NC
29	GUARD	7329	1	
30	WORM	7330	1	
31	PLATE	7331	1	
32	SCREW	7332	1	
33	SEAT FRAME	7333	2	
34	WASHER	7610	2	
35	PILLAR	7335	3	
36	COMPRESSION SPRING		1	ψ4.0*d1.0



# APRON

ITEM NO.	DESCRIPTION	PART NO.	NO.OFF	REMARK
37	COMPRESSION SPRING		ψ6.0*d1.0 2	
38	STEEL BALL		3/16"	1
39	STEEL BALL		1/4"	2
40	FEED ROD	7618		1
41	HANDLE	10305		1
42	NUT		M6	2
43	NUT		M8	1
44	WASHER	7344		1
45	WASHER	7345		1
46	OIL BALL		1/4"	2
47	PARALLEL KEY		1/4"-TP	1
48	PARALLEL KEY		4*4*15	1
49	PARALLEL KEY		5*5*40	1
50	SOCKET SCREW		M6*12	2
51	SOCKET SCREW		M6*16	3
52	SOCKET SCREW		M6*20	8
53	SOCKET SCREW		M5*12	1
54	SOCKET SCREW		M6*40	3
55	SOCKET SCREW		M6*70	1
56	SOCKET SCREW		M8*85	1
57	SET SCREW		M6*6	1
58	SET SCREW		M6*25	2
59	SET SCREW		M8*6	1
60	SET SCREW		M8*30	1
61	SOCKET BUT.		M6*12	2
62	SPRING PIN		ψ5*25L	1
63	SPRING PIN		ψ5*30L	2
64	SPRING PIN		ψ5*40L	1
65	SPRING PIN		ψ5*60L	1
66	CIRCLIP		E12	1
67	WASHER		1002055	1

# SADDLE AND TOP-SLIDE

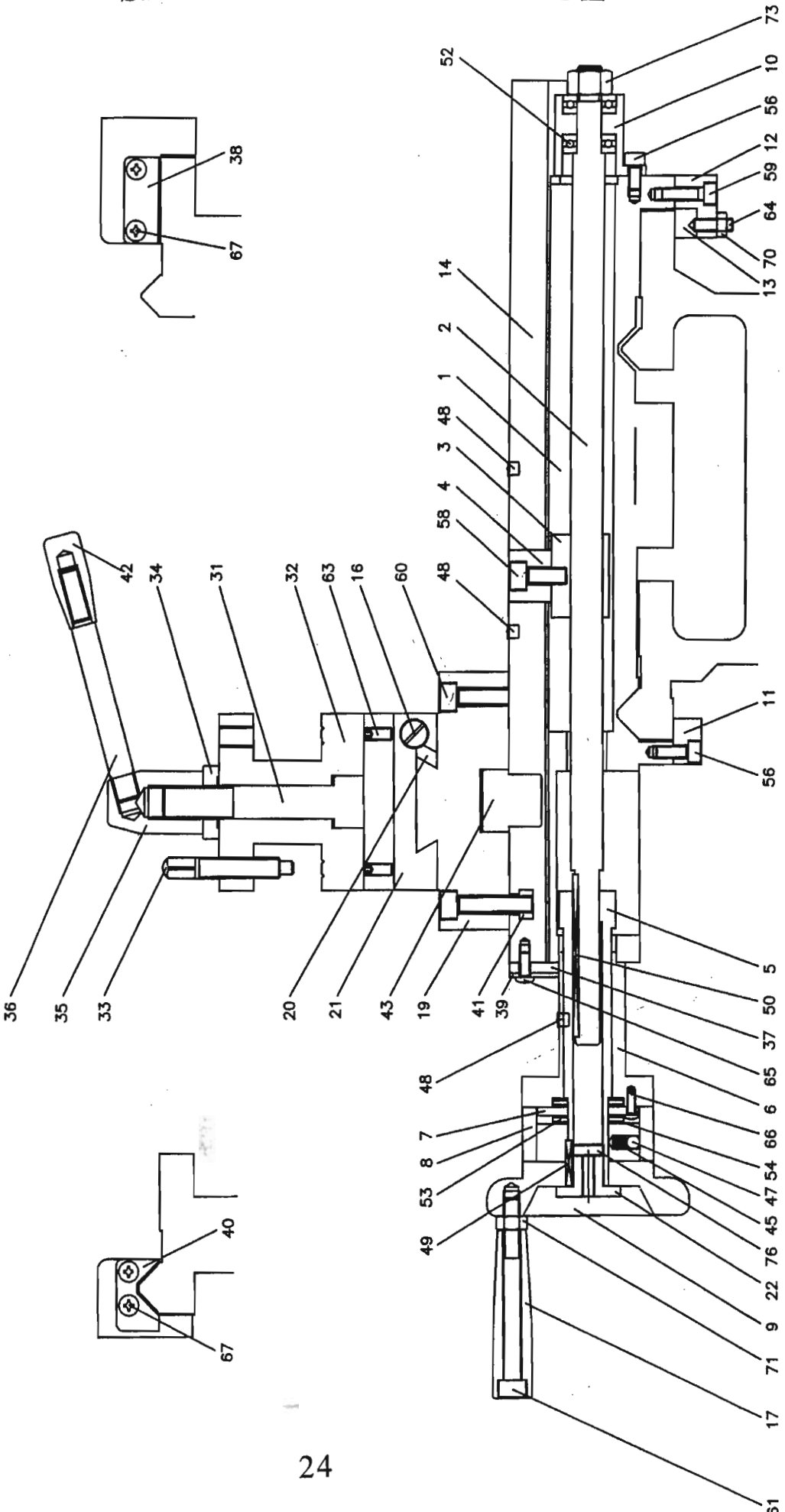

# SADDLE AND TOP-SLIDE

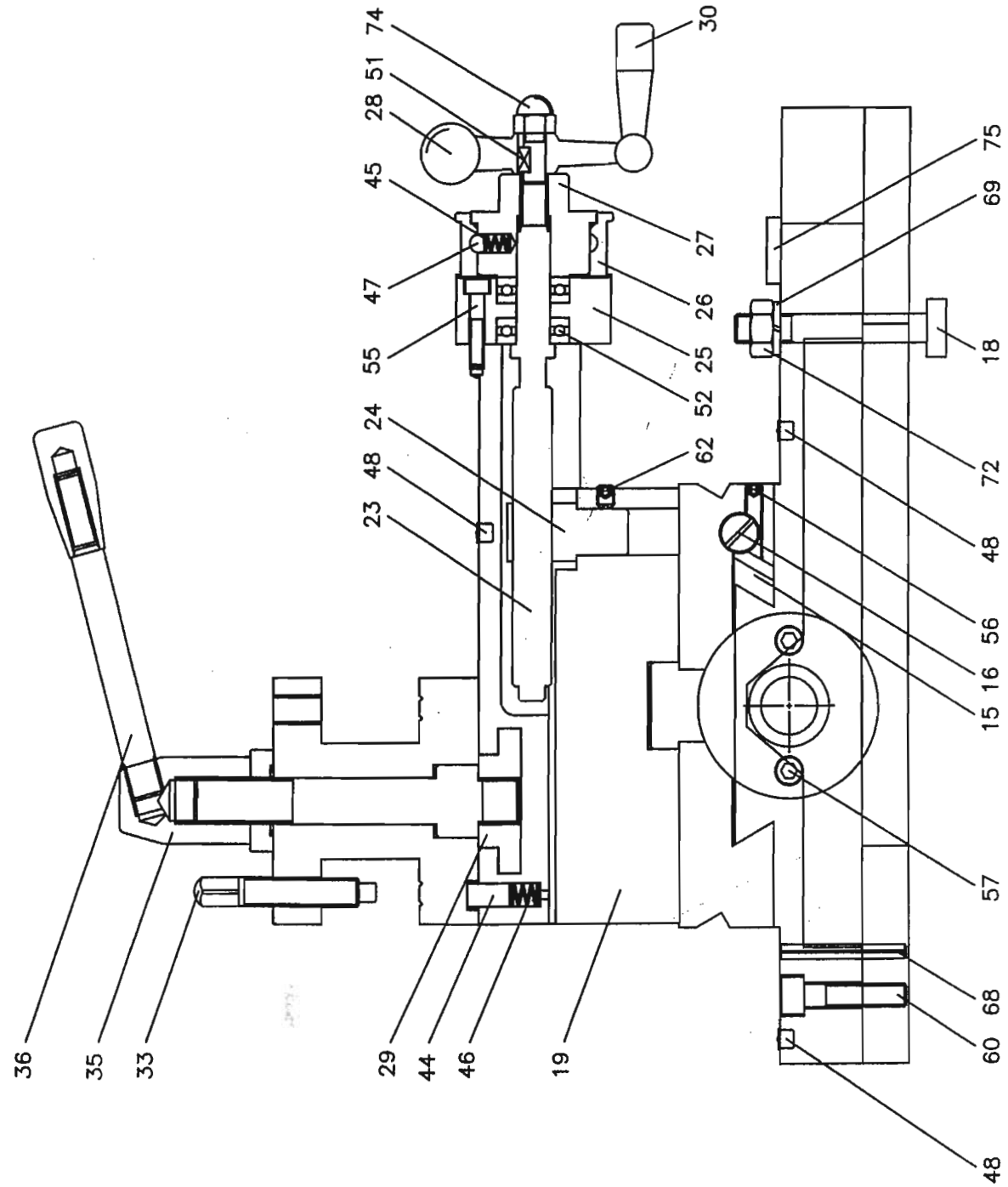

# SADDLE AND TOP-SLIDE

ITEM NO.	DESCRIPTION	PART NO.	NO.OFF	REMARK
1	CASTING	5105	1	
2	SCREW	5107	1	
3	NUT	7403	1	7446
4	NUT ASSY	7404	1	
5	PINION	5111	1	
6	KEEP ASSY	7406-1	1	
7	NUT	7407-1	1	
8	DIAL	7408-1	1	
9	HAND WHEEL	7409-1	1	
10	BRACKET	7410-1	1	
11	STRIP	7411	2	
12	STRIP	5109	1	
13	GIB	5110	1	
14	CROSS SLIDE	5106	1	
15	GIB	5108	1	
16	SCREW	7416	4	
17	HANDLE	10305	1	
18	BOLT	7418	1	
19	SWIVEL SLIDE	5113	1	
20	GIB	7420	1	
21	TOP SLIDE	7221	1	
22	NUT	8407-1	1	
23	SCREW	7423	1	
24	NUT	7424	1	
25	KEEP ASSY	7425	1	
26	DIAL	7426	1	
27	KEEP ASSY	7427	1	
28	HAND WHEEL	7428	1	
29	T-SLOTTED	7429	1	
30	HANDLE	7430	1	
31	SHAFT	7431	1	
32	TURRET BODY	7432	1	
33	SCREW	7433	8	
34	WASHER	7434	1	
35	NUT	7435	1	
36	HANDLE	7436	1	

# SADDLE AND TOP-SLIDE

ITEM NO.	DESCRIPTION	PART NO.	NO.OFF	REMARK
37	WIPER	5112	1	
38	WIPER	9439	1	
39	WIPER PROTECT	5112-1	1	
40	WIPER	7439	1	
41	BLOCK	7441	2	
42	HANDLE	7263	1	
43	PLUG	8440	1	
44	PILLAR	8442	1	
45	COMPRESSION SPRING	ψ6.0*d1.0	2	
46	COMPRESSION SPRING	ψ8.0*d1.0	1	
47	STEEL BALL	1/4"	2	
48	OIL BALL	1/4"	11	
49	PARALLEL KEY	3*3*20	1	
50	PARALLEL KEY	3*3*75	1	
51	PARALLEL KEY	4*4*8	1	
52	BEARING	51101	4	
53	BEARING	NTB2035	2	
54	BEARING	AS2035	4	
55	SOCKET SCREW	M5*30	2	
56	SOCKET SCREW	M6*16	6	
57	SOCKET SCREW	M6*75	2	
58	SOCKET SCREW	M8*20	2	
59	SOCKET SCREW	M8*30	3	
60	SOCKET SCREW	M8*35	4	
61	SOCKET SCREW	M8*85	1	
62	SET SCREW	M6*6	1	
63	SET SCREW	M6*16	3	
64	SET SCREW	M6*20	3	
65	SOCKET BUT.	M5*12	3	
66	COUNTERSUNK BOLT	3/16"*1/4"	2	
67	COUNTERSUNK BOLT	M5*12	8	
68	SPRING PIN	ψ5*36	1	
69	SPRING WASHER	M10	1	
70	NUT	M6	3	
71	NUT	M8	1	
72	NUT	M10	1	

# SADDLE AND TOP-SLIDE

ITEM NO.	DESCRIPTION	PART NO.	NO.OFF	REMARK
73	NUT	M12*P1.25	2	
74	CUP NUT	M8	1	
75	OIL COVER	5/8"-18NF	1	

# TAILSTOCK

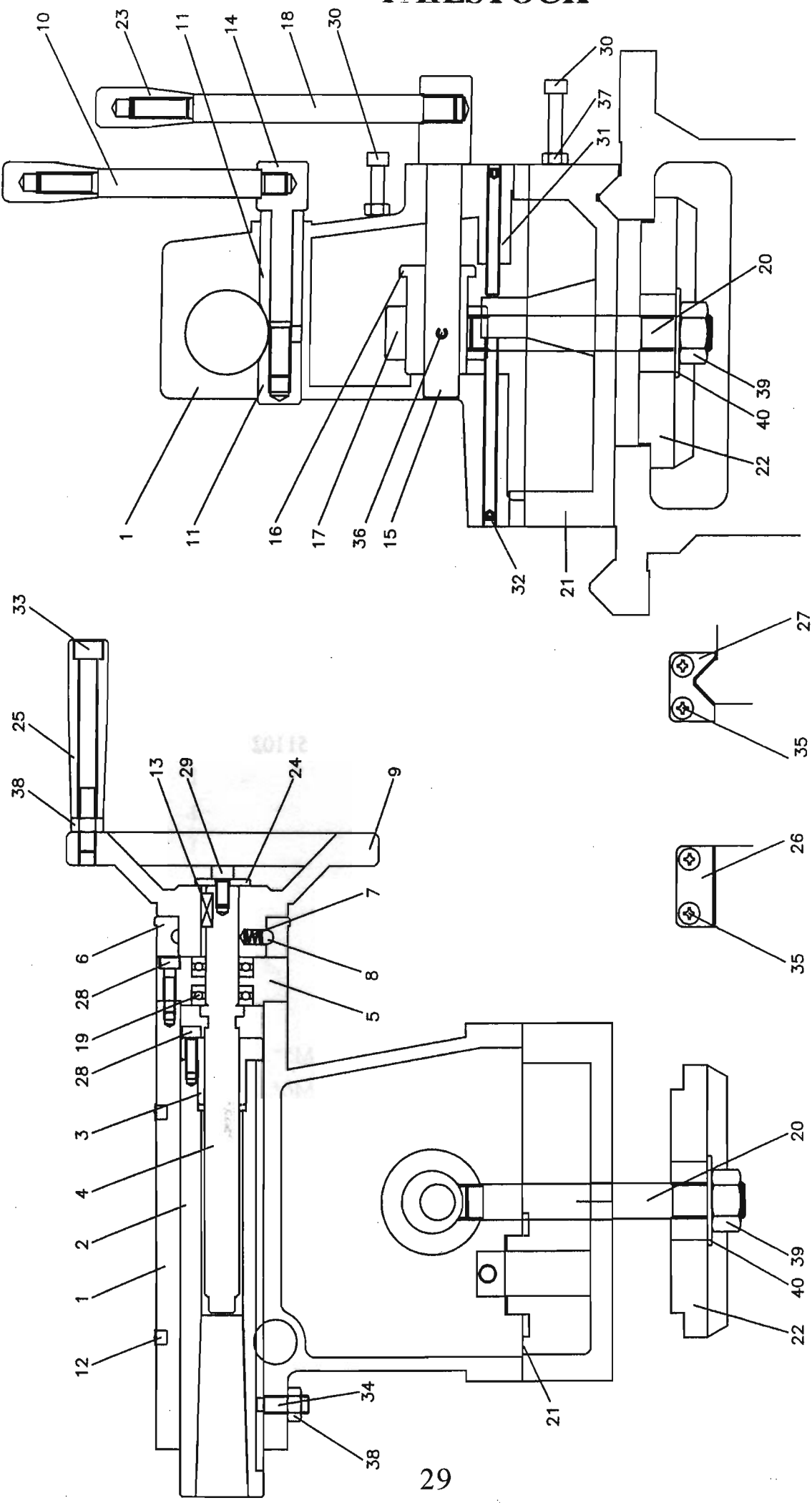

# TAILSTOCK

ITEM NO.	DESCRIPTION	PART NO.	NO.OFF	REMARK
1	CASTING	5114	1	
2	BARREL	7502	1	
3	NUT	7503	1	
4	SCREW	7504	1	
5	KEEP ASSY	7505	1	
6	DIAL	7506	1	
7	COMPRESSION SPRING		ψ6.0*d1.0	1
8	STEEL BALL		1/4"	1
9	HAND WHEEL	7509		1
10	SCREW	7510		1
11	NUT	5117		1
12	OIL BALL		1/4"	2
13	PARALLEL KEY		5*5*15	1
14	HANDLE	7514		1
15	SHAFT	7515		1
16	PIVOT BLOCK	7516		1
17	SLEEVE	7517		1
18	HANDLE	7518		1
19	BEARING		51102	2
20	BOLT	5116		1
21	BASE	5115		1
22	CLAMP PLATE	5132		1
23	HANDLE	7263		2
24	WASHER	7610		1
25	HANDLE	10305		1
26	WIPER	7053		2
27	WIPER	7439		2
28	SOCKET SCREW		M5*25	3
29	SOCKET SCREW		M6*12	1
30	SOCKET SCREW		M6*40	2
31	SOCKET SCREW		M8*85	1
32	SET SCREW		M6*45	1
33	SET SCREW		M6*65	1
34	SET SCREW		M8*20	1
35	COUNTERSUNK SCREW		M5*12	8
36	SPRING PIN		ψ5*25	1



# TAILSTOCK

ITEM NO.	DESCRIPTION	PART NO.	NO.OFF	REMARK
37	NUT		M6 2	
38	NUT		M8 2	
39	NUT		5/8"-11NC 1	
40	WASHER		5/8" 1	

# BED

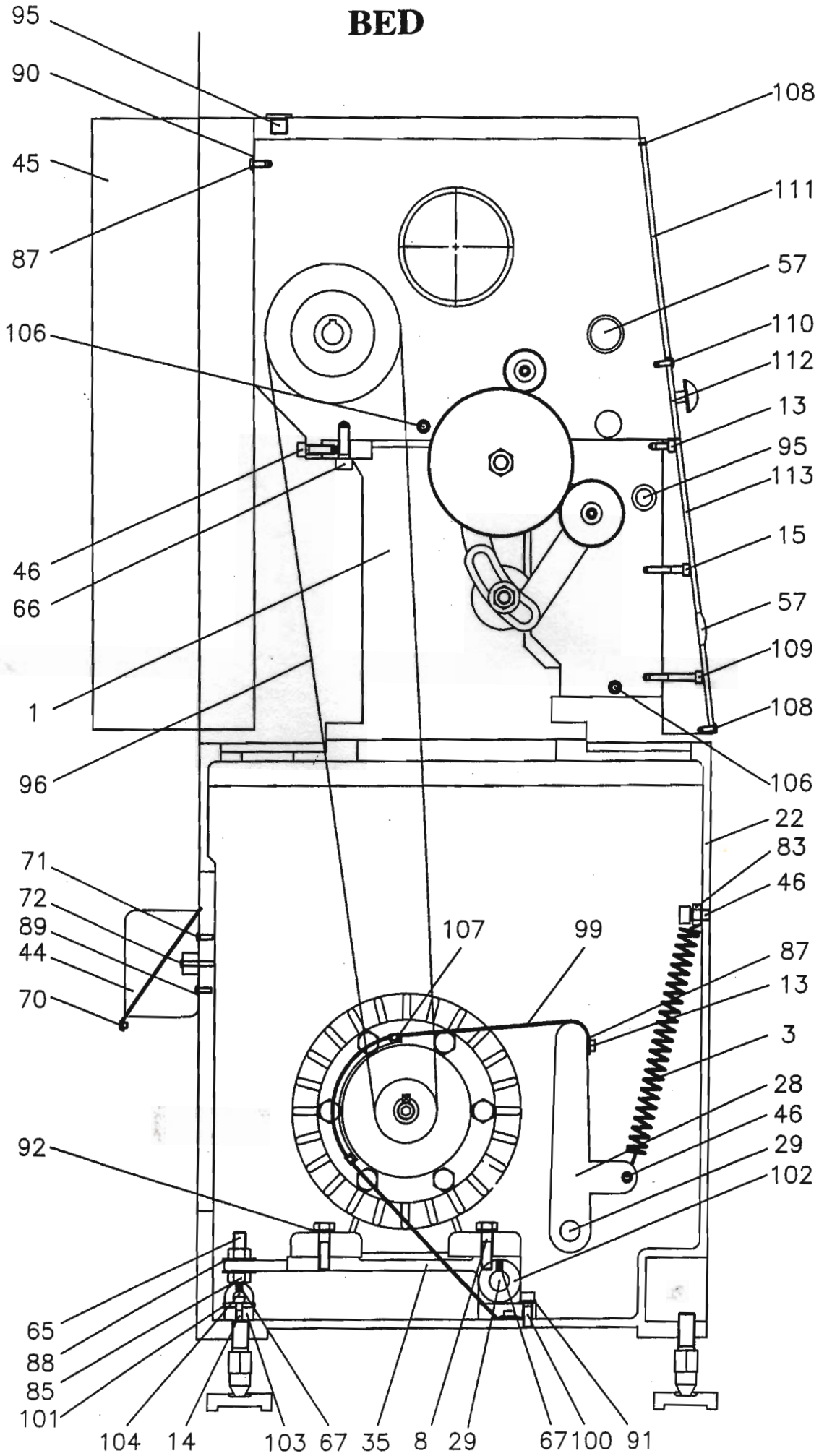

# BED

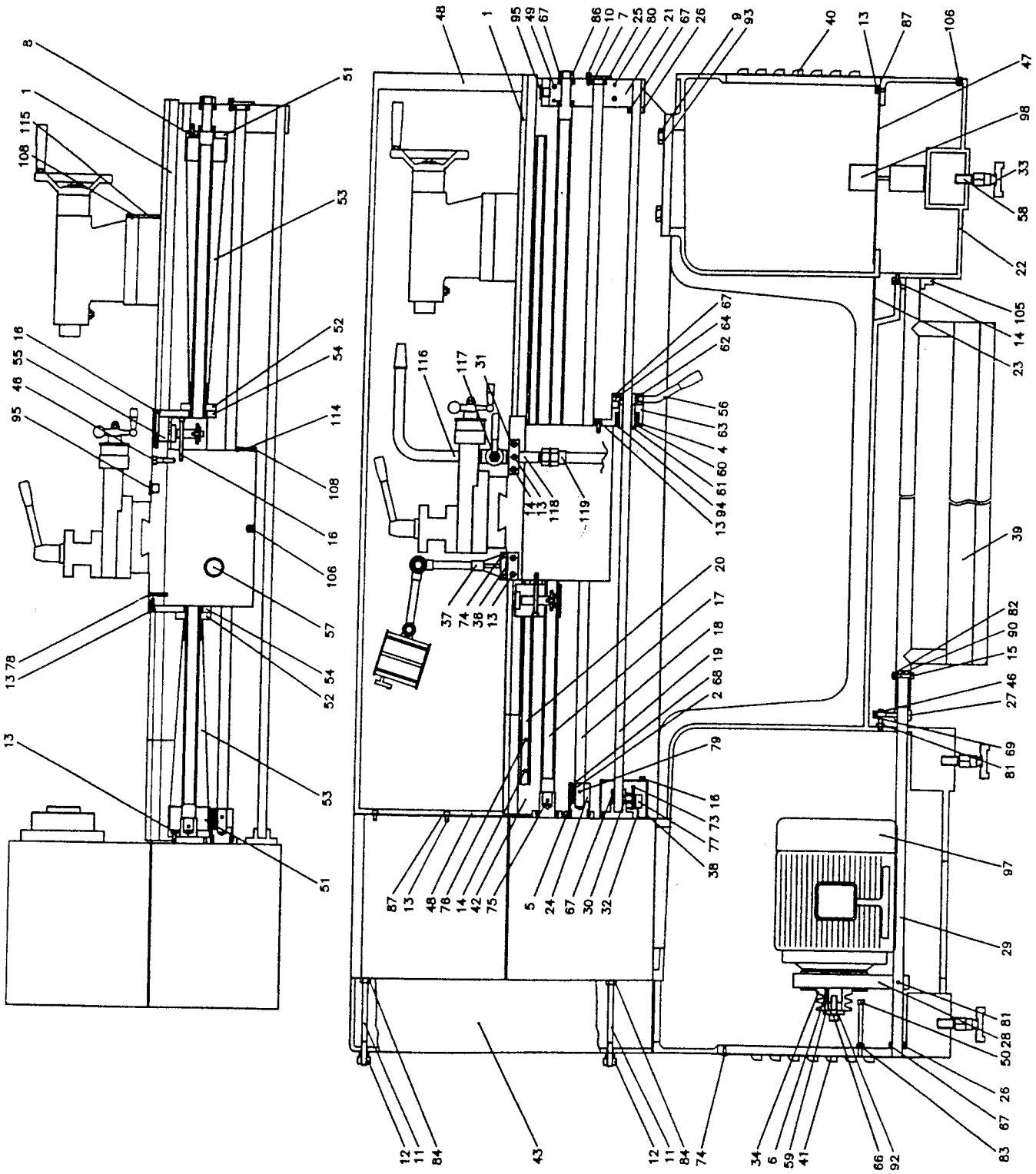

# BED

ITEM NO.	DESCRIPTION	PART NO.	NO.OFF	REMARK
1	BED	5118	1	
2	COMPRESSION SCREW		ψ6.0*d1.0 4	
3	COMPRESSION SCREW		ψ12*d2.0*100L 1	
4	COMPRESSION SCREW		ψ45*d5.0*20L 1	
5	STEEL BALL		1/4" 4	
6	PARALLEL KEY		7*7*70 1	
7	BEARING		51103 3	
8	HEX SCREW		M10*25 4	
9	HEX SCREW		1/2"*2" 8	
10	SOCKET		M5*12 2	
11	BOLT	7611	2	
12	NUT	7612	2	
13	SOCKET SCREW		M6*12 12	
14	SOCKET SCREW		M6*20 12	
15	SOCKET SCREW		M6*35 1	
16	SOCKET SCREW		M6*70 5	
17	LEAD SCREW	7617	1	
18	FEED ROD	7618	1	
19	THIRD-ROD	7619	1	
20	ROCK	7620	1	
21	BRACKET	7621	1	
22	FLOOR	5119	1	
23	OIL NET	5133	1	
24	SAFETY ASSY	7624	1	
25	COVER	7625	1	
26	BUSH	7626	1	
27	BUSH	7627	1	
28	LEVER	7628	1	
29	SHAFT	5123	1	
30	SELECTOR	7630	1	
31	BRACKET	7631	1	
32	BRACKET	7632	1	
33	BLOCK	7633	6	
34	PULLEY	7634	1	
35	MOTOR PLATE	5124	1	
36	FIXED RACK		1	

# BED

ITEM NO.	DESCRIPTION	PART NO.	NO.OFF	REMARK
37	HALOGEN LIGHT		1	
38	COVER	5134	1	
39	FOOT BRAKE	5122	1	
40	COVER	5120	2	
41	COVER	5121	2	
42	GAP	7642	1	
43	ENC COVER	5126	1	
44	BOX	7644	1	
45	ELECTRICAL BOX	5127	1	
46	SOCKET SCREW		M8*35	10
47	POMPU BOX	5125	1	
48	SPLASH GUARD	7648	1	
49	SOCKET SCREW		M8*55	2
50	SOCKET SCREW		M8*90	1
51	BLOCK	7651	1	
52	BLOCK	7652	1	
53	SPRING COVER	7653	2	
54	PLANK	7654	1	
55	BLOCK	7655	1	
56	HANDLE	7656	1	
57	FUEL LEVER		ψ29	3
58	SCREW	7658	1	
59	WASHER	8143	1	
60	WASHER	8618	1	
61	BUSH	8619	1	
62	KEEP ASSY	8620	1	
63	BRACKET	8621	1	
64	PLUG	8622	1	
65	SCREW	8635	1	
66	SOCKET SCREW		M10*35	5
67	SET SCREW		M6*6	9
68	SET SCREW		M8*6	4
69	SET SCREW		M8*30	2
70	COUNTERSUNK SCREW		3/16"*3/8"	1
71	COUNTERSUNK SCREW		3/16"*1/4"	2
72	COUNTERSUNK SCREW		3/16"*1/2"	2

# BED

ITEM NO.	DESCRIPTION	PART NO.	NO.OFF	REMARK
73	COUNTERSUNK SCREW		M4*40 2	
74	COUNTERSUNK SCREW		M6*12 16	
75	TAPER PIN		3#*32 1	
76	SPRING PIN		ψ5*20 7	
77	LIMIT SWICH		1	
78	SPRING PIN		ψ5*36 2	
79	SPRING PIN		ψ5*40 1	
80	SPRING PIN		ψ5*55 2	
81	SPRING PIN		ψ6*40 1	
82	NUT		M6 1	
83	NUT		M8 2	
84	NUT		3/8"-16NC 2	
85	NUT		1/2"-14NC 2	
86	NUT		5/8"-11NF 1	
87	WASHER		M6 9	
88	WASHER		ψ1/2" 2	
89	WASHER		ψ3/16" 1	
90	SPRING WASHER		M6 1	
91	SPRING WASHER		ψ8 3	
92	SPRING WASHER		M10 4	
93	SPRING WASHER		ψ1/2" 8	
94	CIRCLIP		S30 1	
95	OIL SEAL		3/8"-16NF 3	
96	V-BELT		A67 2	
97	MOTOR		1	
98	POMPU		1	
99	BRAKE LINING		1	
100	SOCKET SCREW		M8*25" 3	
101	WASHER	7116	4	
102	KEEP ASSY	8632	1	
103	KEEP ASSY	8634	2	
104	SHAFT	8636	2	
105	BRACKET	8617	1	
106	SET SCREW		PT1/2" 4	
107	SCREW		ψ5 2	
108	SCREW		ψ2 10	

# BED

ITEM NO.	DESCRIPTION	PART NO.	NO.OFF	REMARK
109	SOCKET		M6*45 3	
110	SOCKET SCREW		M5*8 10	
111	PLATE OF HEADSTOCK	7151	1	
112	PLATE OF ELECTRIC	7162	1	
113	PLATE OF GEAR BOX	7262	1	
114	PLATE OF APRON	7341	1	
115	PLATE OF TAILSTOCK	7527	1	
116	OIL PIPE		1	
117	OIL CONTROL VALVE		1	
118	DUCT		1	
119	PROTECT PIPE		1	

# GEAR TRAIN

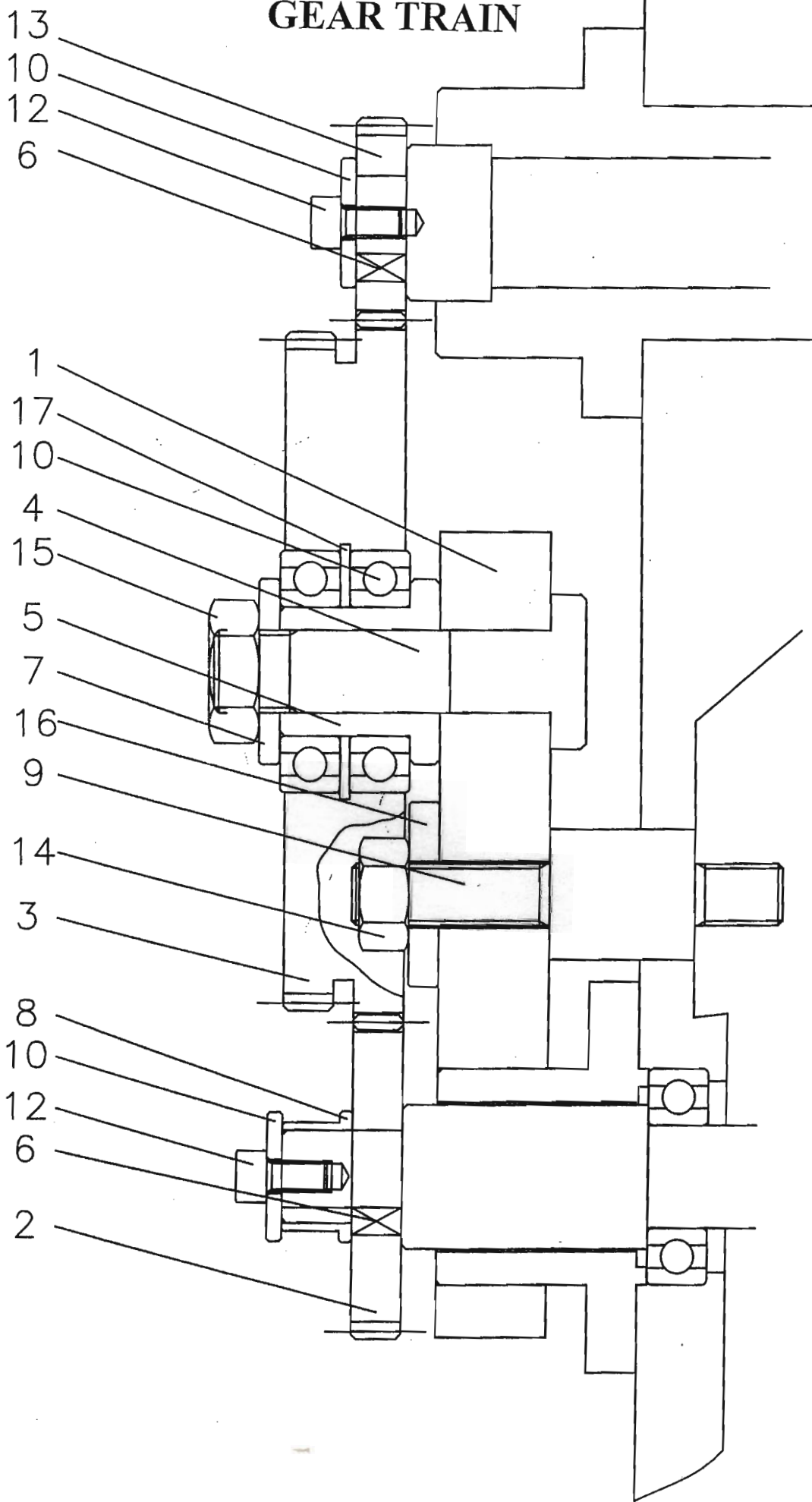



# GEAR TRAIN

ITEM NO.	DESCRIPTION	PART NO.	NO.OFF	REMARK
1	SWING FRAME	7616	1	
2	GEAR	7602	1	
3	GEAR	7603	1	
4	SHAFT	7604	1	
5	BUSH	7605	1	
6	PARALLEL KEY		5*5*10	2
7	WASHER	7607		1
8	COLLAR	7608		1
9	BOLT	7609		1
10	WASHER	7610		2
11	BEARING		6005ZZ	2
12	SOCKET SCREW		M6*16	2
13	GEAR		7613	1
14	NUT		1/2"-12NC	1
15	NUT		5/8"-11NC	1
16	WASHER		1/2"	1
17	CIRCLIP		R47	1

# STEADY/FOLLOW REST AND BED MICRO STOP SET

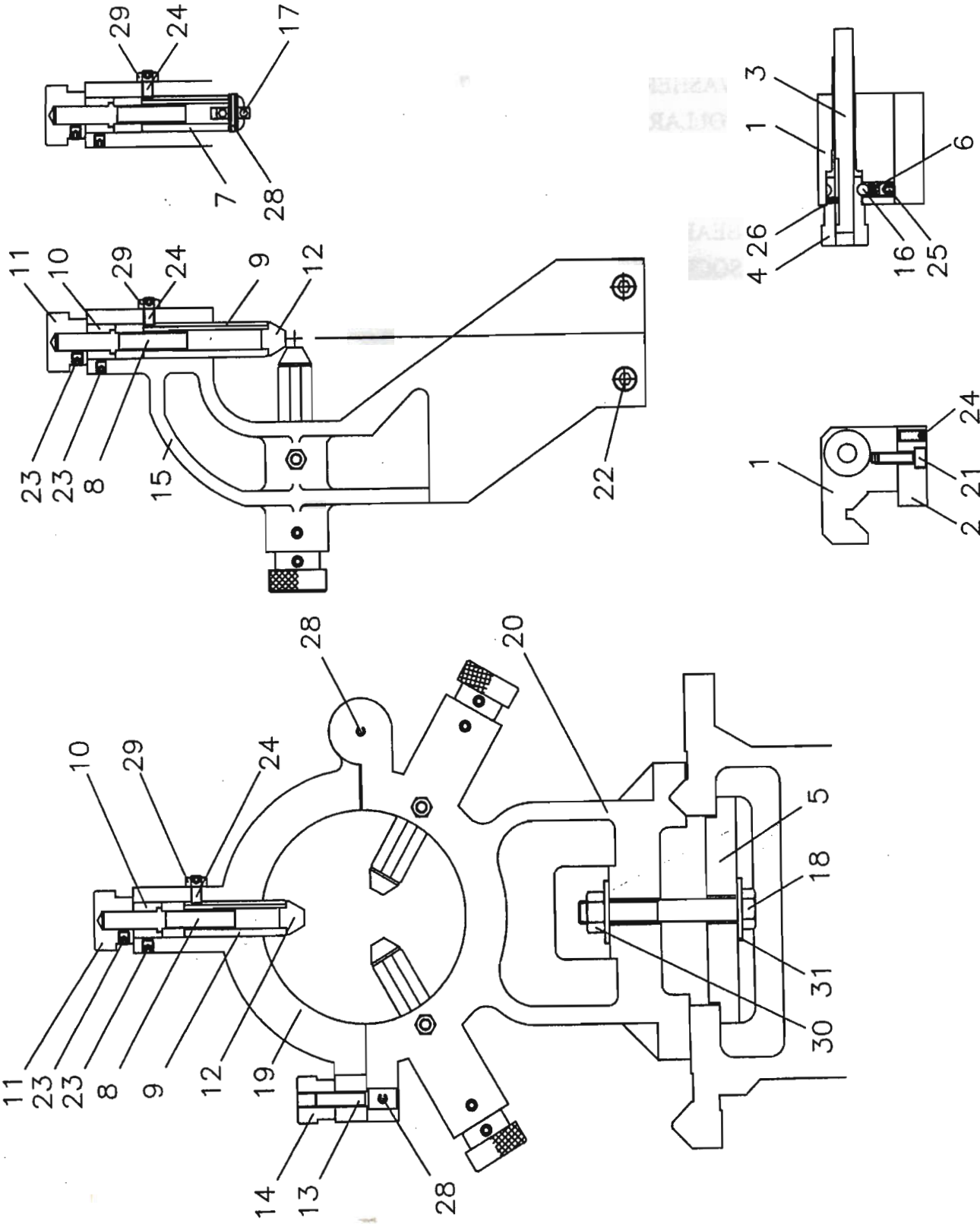

# STEADY/FOLLOW REST AND BED MICRO STOP SET

ITEM NO.	DESCRIPTION	PART NO.	NO.OFF	REMARK
1	BED MICRO STOP CASTING	7701	1	
2	PLANK	7702	1	
3	SCREW	7703	1	
4	DIAL	7704	1	
5	CLAMP PLATE	5132	1	
6	COMPRESSION SPRING	ψ6.0*d0.5	1	
7	SHAFT	7709-1	5	
8	SCREW	7708	5	
9	SHAFT	7709	5	
10	BUSH	7710	5	
11	HANDLE	7711	5	
12	PACKING	7712	5	
13	BOLT	7713	1	
14	NUT	7714	1	
15	FOLLOW REST CASTING	5130	1	
16	STEEL BALL	1/4"	1	
17	BEARING	635ZZ	5	
18	HEX SCREW	1/2"-12NC*3"	1	
19	STEADYREST TOP CASTING	5128	1	
20	STEADYREST SET CASTING	5129	1	
21	SOCKET SCREW	M6*25	2	
22	SOCKET SCREW	M8*35	2	
23	SET SCREW	M6*6	10	
24	SET SCREW	M6*16	7	
25	SET SCREW	M8*6	1	
26	SPRING PIN	ψ3*6	1	
27	SPRING PIN	ψ5*20	5	
28	SPRING PIN	ψ5*30	2	
29	NUT	M6	5	
30	NUT	1/2"-12NC	1	
31	WASHER	ψ1/2"	2	