

# CONTENTS

4-11 4-Position Automatic Feeding Stop Operation.....	18
4-12 Tailstock Operation.....	19
4-13 Rapid Traverse Operation (Optional device).....	20
<b>5. THREADING</b>	
5-1 Leadscrew Drive.....	21
5-2 Threading.....	21
5-3 Thread Dial Indicator.....	21
5-4 Thread & Feed Chart.....	23
5-5 Module & D.P. Thread Chart.....	26
<b>6. LUBRICATION</b>	
6-1 Headstock Lubrication.....	28
6-2 Gear Box & Apron Lubrication.....	28
6-3 Lubrication Charts.....	28
6-4 Lubrication Location.....	29
<b>7. MAINTENANCE &amp; ADJUSTMENT</b>	
7-1 Headstock.....	30
7-2 Apron & Saddle.....	31
7-3 Gear Box.....	32
7-4 Tailstock Center Line Adjustment.....	32
7-5 Belt Tension Adjustment.....	33
7-6 Brake Belt Adjustment.....	33
7-7 Brake & Micro Switch Adjustment.....	34
7-8 Leadscrew Backlash Adjustment.....	34
7-9 Cutting Coolant Repair.....	34
<b>8. PART LISTS.....</b>	<b>35</b>

# **CONTENTS**

<b>PREFACE.....</b>	<b>3</b>
<b>1. WH HIGH SPEED PRECISION LATHE</b>	
1-1 Machine Assembly.....	4
<b>2. UNPACKING &amp; MACHINE INSTALLATION</b>	
2-1 Unpacking.....	6
2-2 Lifting.....	6
2-3 Basic Foundation.....	7
2-4 Cleaning.....	7
2-5 Level Adjustment.....	8
<b>3. ELECTRICAL CIRCUIT CONTROL</b>	
3-1 Electrical Wiring.....	9
3-2 Electrical Equipment.....	9
3-3 Electrical Cautions.....	9
3-4 Circuit Diagram.....	10
<b>4. TESTING &amp; OPERATION</b>	
4-1 Operation Symbols.....	13
4-2 Transmission & Stop of Spindle.....	14
4-3 Spindle Speed Selection.....	14
4-4 Intermittent Operation of Spindle.....	15
4-5 The Importance and Methods of Spindle Leveling Adjustment.....	16
4-6 Transmission & Stop of Gear Box.....	17
4-7 Gear Box Operation.....	17
4-8 Manual Operation.....	17
4-9 Automatic Feeding Operation.....	18
4-10 Automatic Feeding Stop Operation.....	18

# 1. WH HIGH SPEED PRECISION LATHE

## 1-1 Machine Assembly

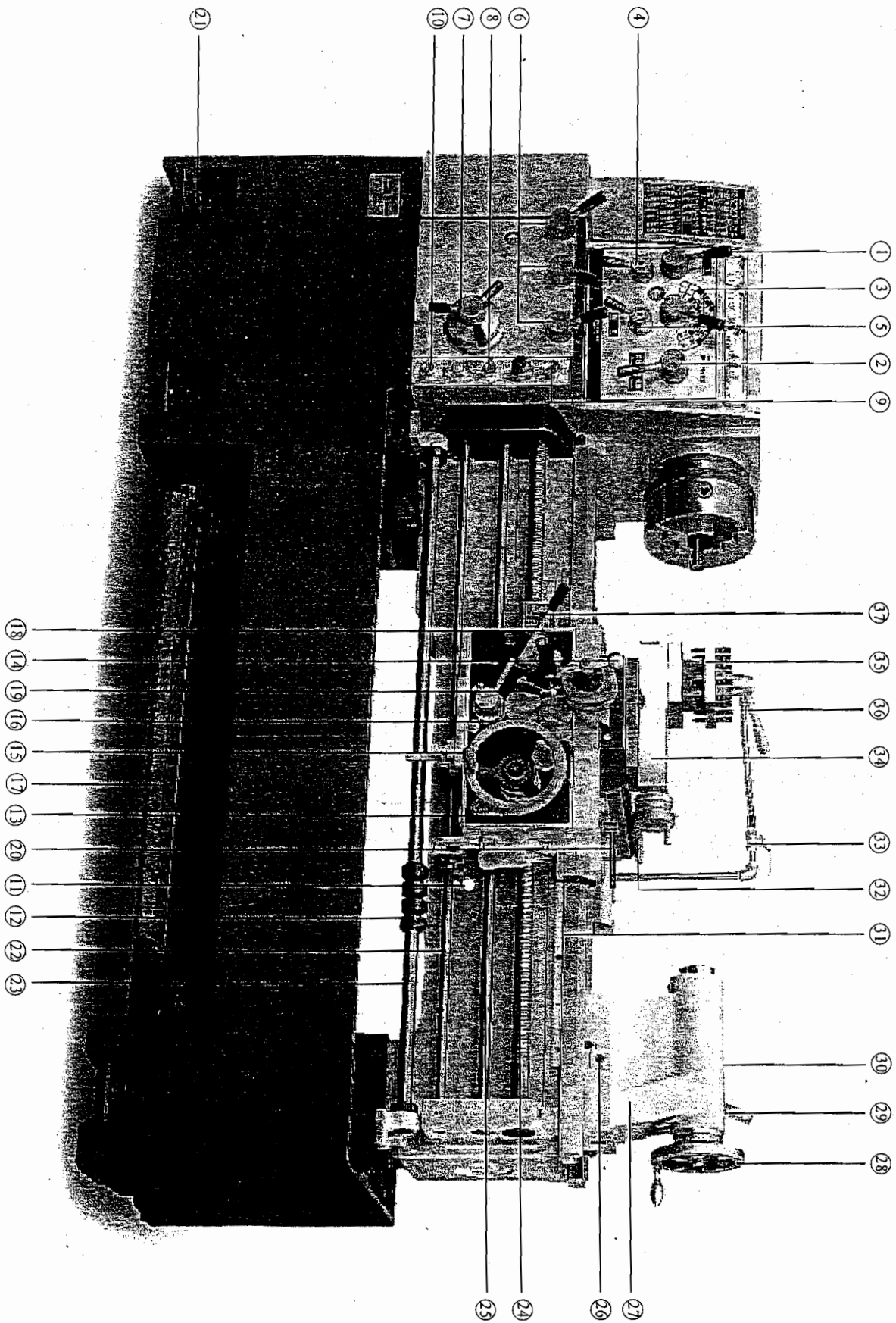

Fig. 1-1

ITEM	DESCRIPTION	ITEM	DESCRIPTION
1	Spindle speed shifting lever	20	Carriage clamping lever
2	Spindle speed H/L shifting lever	21	Foundation adjusting bolt
3	Spindle speed shifting selection lever	22	Spindle operation control rod
4	Forward/Reverse Shifting lever	23	4 position automatic feed stop selection rod
5	Thread/Feed Selection lever	24	Leadscrew
6	Thread/Feed Shifting lever	25	Auto-feed rod
7	10-step feed selection dial	26	Tailstock set over adjusting Screw
8	Power source switch (Main switch)	27	Tailstock body
9	Intermittent button	28	Tailstock handwheel
10	Coolant supply button	29	Tailstock body Clamping lever
11	Spindle operation control lever	30	Tailstock spindle locking lever
12	Adjustable trip dog	31	Rack
13	Longitudinal feed hand wheel	32	Compound rest handle
14	Cross slide handle	33	Coolant control valve
15	Trip plunger	34	Compound rest
16	Auto feeding engaged lever	35	Four way tool post
17	Foot brake pedal	36	Tool post clamping lever
18	Half nut engaged lever	37	Thread dial indicator
19	Feed axis selector		

## 2. UNPACKING & MACHINE INSTALLATION

### 2-1 Unpacking

When the machine is arrived, first, check if the wooden case is damaged or not, secondly, open the case and inspect the machine for any damage or short supply of parts. If so, please contact our company or insurance company immediately in order to get the best solution or refund; otherwise our company or the insurance company will not be in the position to compensate for the damage.

### 2-2 Lifting

Please refer to figure 2-2 for machine unloading from the truck & moving:

The steps of lifting the lathes are:

- (1) Clamp the bedways with a special made hanger, which consists of a clamp and an iron chain.
- (2) Raise the lathe a little bit with crane, then check if the lathe is balanced. If not, move apron and cross slide back or forth to make the machine is balanced.
- (3) While the machine arrives at the location, put down the machine slowly to avoid any inaccuracy of the machine caused by bumps or crash.
- (4) For adjusting the electrical cabinet, the machine should be located allowing sufficient area, min. over 600mm from wall at back and tailstock end.

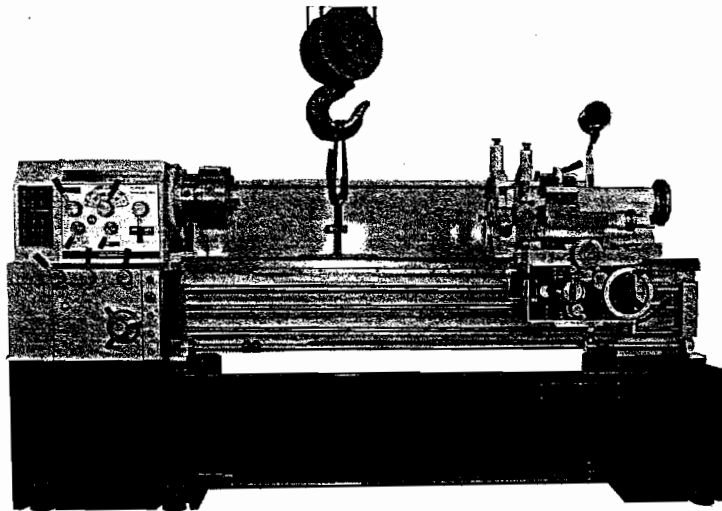
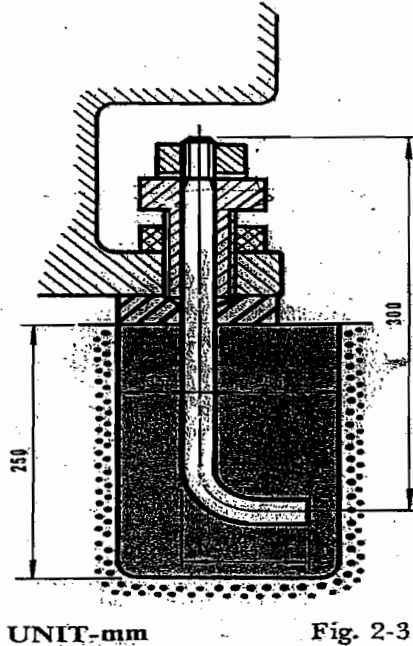

Fig. 2-2

## 2 - 3 Basic Foundation

With the common usage of tungsten carbide cutting tools nowadays, heavy cutting and quicker spindle speed are therefore reinforced. This may cause the vibration easily. In order to ascertain the best cutting condition it is necessary to build a sound & good floor basis. (Please refer to figure 2-3 for basic structure.)



## 2 - 4 Cleaning

The machine is protected with a special anti-rust agent before delivery. Before operating the machine, clean all parts, especially the slideways, leadscrew, rack and all bright surfaces with soft brush/cloth soaked with cleaning solvent or kerosene. Do **NOT** use gasoline or cellulose solvent to avoid dangers or fire or explosion. After removing the anti-agent, keep the machine properly lubricated. Then turn the moving mechanism like tool post, tailstock by hand back & forth within their moving areas.

## 2 – 5 Level Adjustment

Once the set screw and concrete are completely dried and fixed. It is time to adjust the level of the bedway. A machinist's level (accuracy 0.02mm/1000mm) should be placed on the slide-ways of bed. Adjust the set screw for longitudinal direction of bed level. For transverse direction of bed level, tight the nuts until the accuracy is within 0.04mm/1000mm. Then check again.

If the deviation is resulted from the nuts, it is necessary to make another adjustment. (See Fig 2-5)

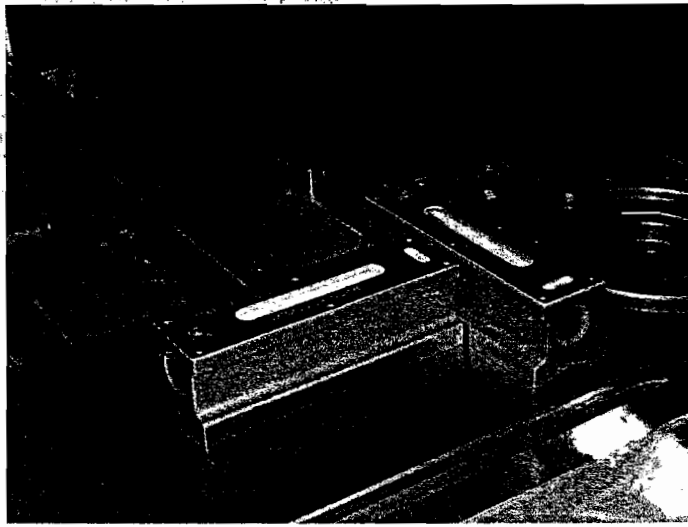

Fig 2-5

### 3. ELECTRICAL CIRCUIT CONTROL

#### 3-1 Electrical Wiring

The electrical control box can be found by opening its cover at the back side of bed. Connect the power source wire with the connecting points (R.S.T)

The wire between the power source and the connecting points must be over sectional area  $8\text{mm}^2$  ( $5.5\text{mm}^2$  for 480 or 19" series).

The main switch between machine and power source also should be equipped with safety fuse. Besides, the machine must have a earth wire.

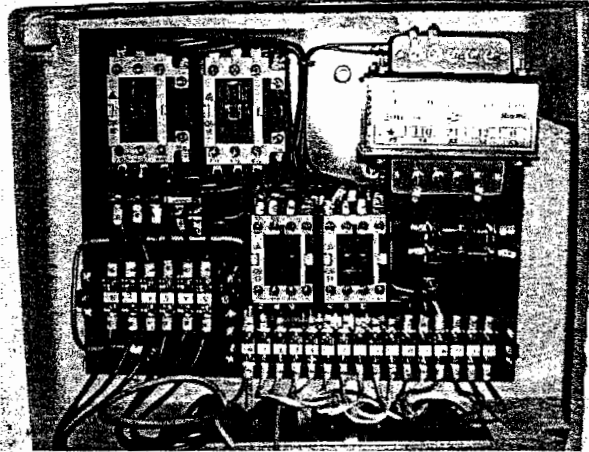

Fig. 3-1

#### 3-2 Electrical Equipment

1. The electrical control box is also equipped with overload circuit breaker and electric magnetic contactor to protect motor from burning out by overload.
2. The main switch is connected with micro switch.
3. The foot brake is connected with micro switch. Stepping the footbrake is quicker to stop the lathe than turning off the switch. The spindle can only revolute again by re-operating the spindle operation control lever after using the foot brake.
4. The spindle will rotate continuously as long as the intermittent switch on the top of the electrical panel is pressed.

#### 3-3 Electrical Cautions

After wiring, check the rotation of the spindle of the spindle. Turn the main switch "ON" and make sure the safety of spindle. Then push intermittent button (T) momentarily. The correction direction of the spindle rotation is counter clockwise. (looking from tailstock for a downward movement of the spindle operation control lever.) Wrong direction of rotation can be rectified by interchanging any two of the three phase lines (R.S.T.) in the power source.



### 3-4 Circuit Diagram

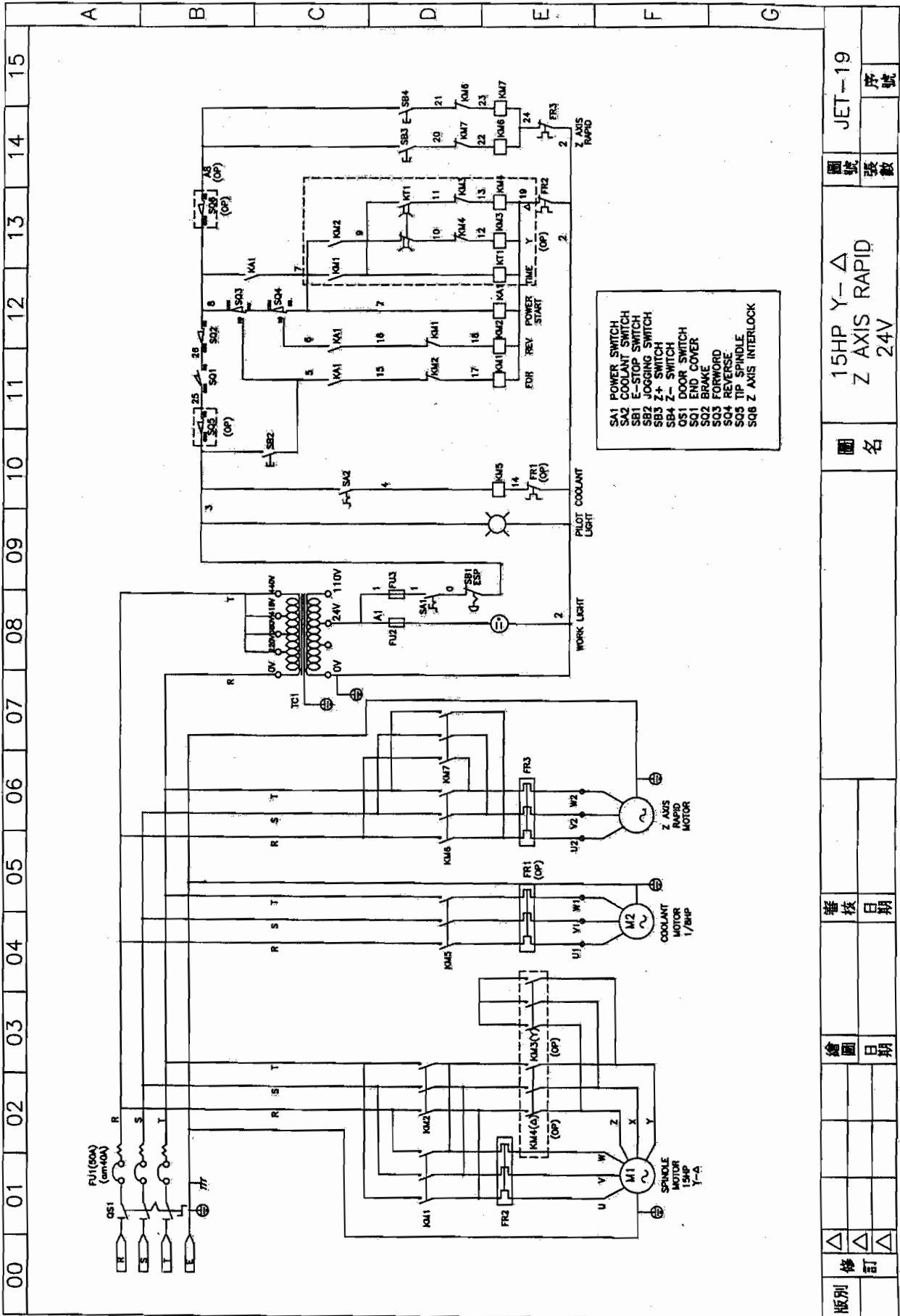

板別		修訂		繪圖		審核		圖名	15HP Y-Δ Z AXIS RAPID 24V	圖號	JET-19	張數		序號	
----	--	----	--	----	--	----	--	----	---------------------------------	----	--------	----	--	----	--



25\*65

M.C.B DZ67H C30A-50A  
Or  
14\*51\*3P am40A-50A

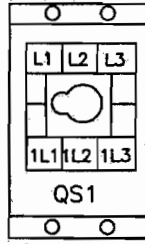

220V-230V  
(P1-32/V/SVB)  
380V-440V  
(P1-25/V/SVB)

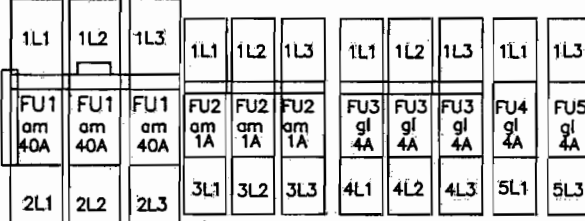

200V-230V am50A  
380V-440V am40A

10\*38\*3P  
am1A

10\*38\*3P  
am4A

25\*65

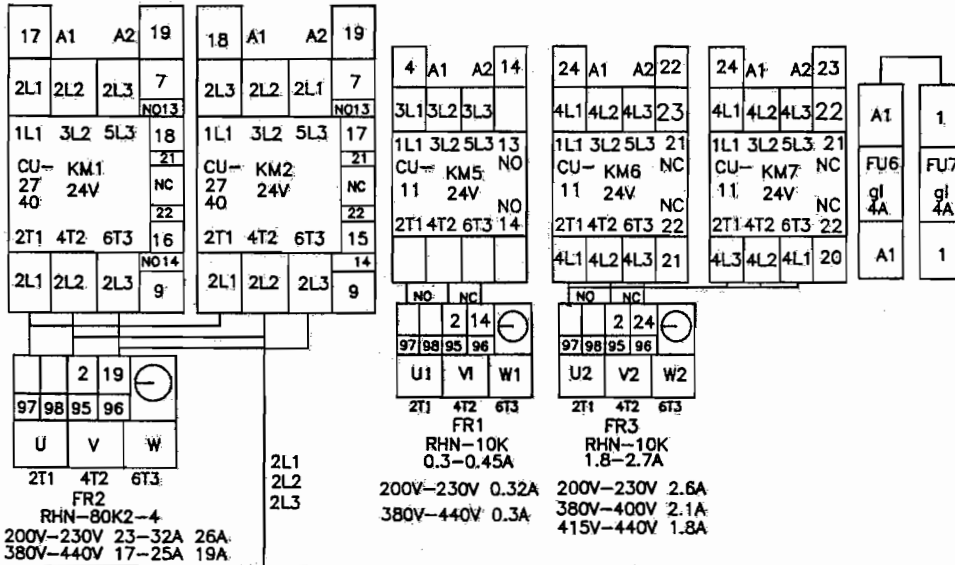

2T1 4T2 6T3  
FR2  
RHN-80K2-4  
200V-230V 23-32A 26A  
380V-440V 17-25A 19A

2T1 4T2 6T3  
FR1  
RHN-10K  
0.3-0.45A  
200V-230V 0.32A  
380V-440V 0.3A

2T1 4T2 6T3  
FR3  
RHN-10K  
1.8-2.7A  
200V-230V 2.6A  
380V-400V 2.1A  
415V-440V 1.8A

25\*65

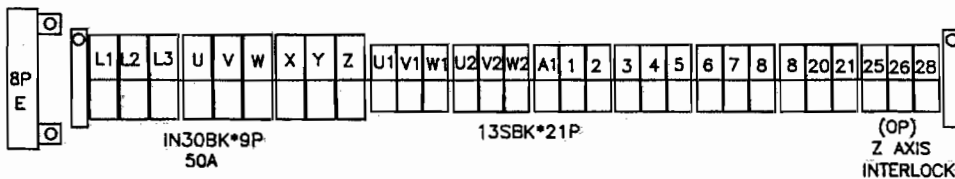

IN30BK\*9P  
50A

13SBK\*21P













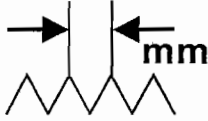
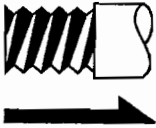

(OP)  
Z AXIS  
INTERLOCK

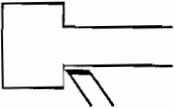
機型 15HP Y-△  
Z AXIS RAPID CE

圖號 JET-21

## 4. TESTING & OPERATION

### 4-1 Operation Symbols

1	<b>HIGH</b>	High speed revolution	11		Variable adjustment (pressure) Clockwise: pressure increase Counterclockwise: pressure decrease
2	<b>LOW</b>	Low speed Revolution	12		Electrical control box
3		Forward revolution	13		Imperial threads
4		Neutral gear	14		Metric threads
5		Reverse revolution	15		Auto feeding Rate per revolution
6		Feeding	16		Pump
7		Intermittent button	17		Power switch-ON
8		Cross feeding	18		Power switch-OFF
9		Longitudinal feeding	19	<b>OIL</b>	Oil inlet (hole)
10		Cone clutch			

## 4-2 Transmission & Stop of Spindle

After the procedure described previously in this manual have been done, it is time to test the machine.

Position the spindle speed H/L shifting lever ② to “L”, the spindle speed shifting selection lever ③ to the very left side, and forward/reverse shifting lever ④ to “N” position. Lift the spindle operation control lever (⑪ of figure 1-1), the spindle will rotate forward, press down the lever, the spindle will rotate reverse; in ‘Neutral’ position, the spindle will stop. For normal forward & reverse revolution, always operate the spindle operation control lever. For emergency stop, step on the foot brake, the spindle operation control lever should push back to ‘Neutral’ position after stepping the foot brake. Afterward, start the spindle.

Turn the coolant supply button (⑩ of figure 1-1). Adjust the adjusting valve for the required coolant flow.

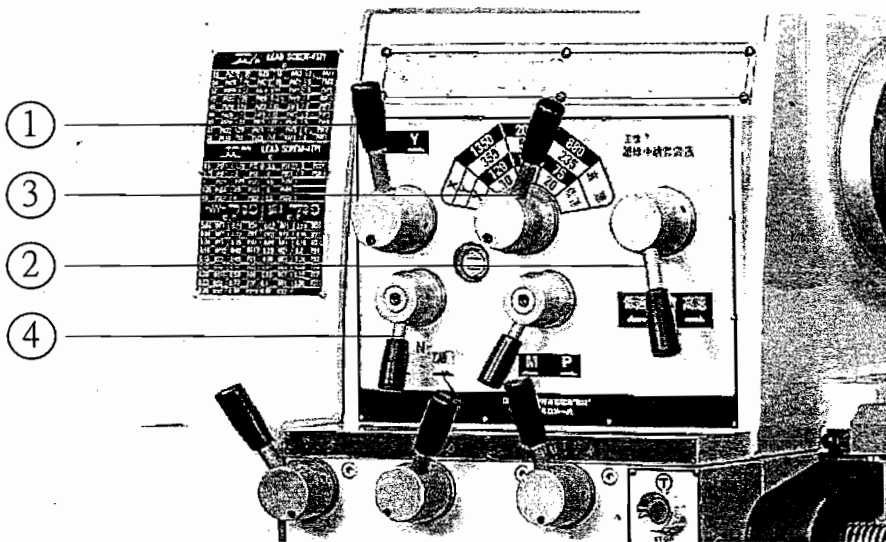

Fig.4-2

## 4-3 Spindle Speed Selection

Spindle speed shift is made up of three speed shifting levers:

1. Spindle speed shifting lever
2. Spindle speed H/L shifting lever
3. Spindle speed shifting selection lever for total of 12 spindle speed numbers

Put the spindle speed H/L shifting lever to ‘neutral’ gear between ‘H’ and ‘L’ rotate the spindle by hand.

For safety and protecting the gears from damage, only change speeds when the motor is completely stopped. If the gears are not easily engaged, press intermittent button and handle the speed shifting levers to change the speeds.

**Caution:** Do not shift gears while spindle is turning. Be certain gears are properly engaged before starting.

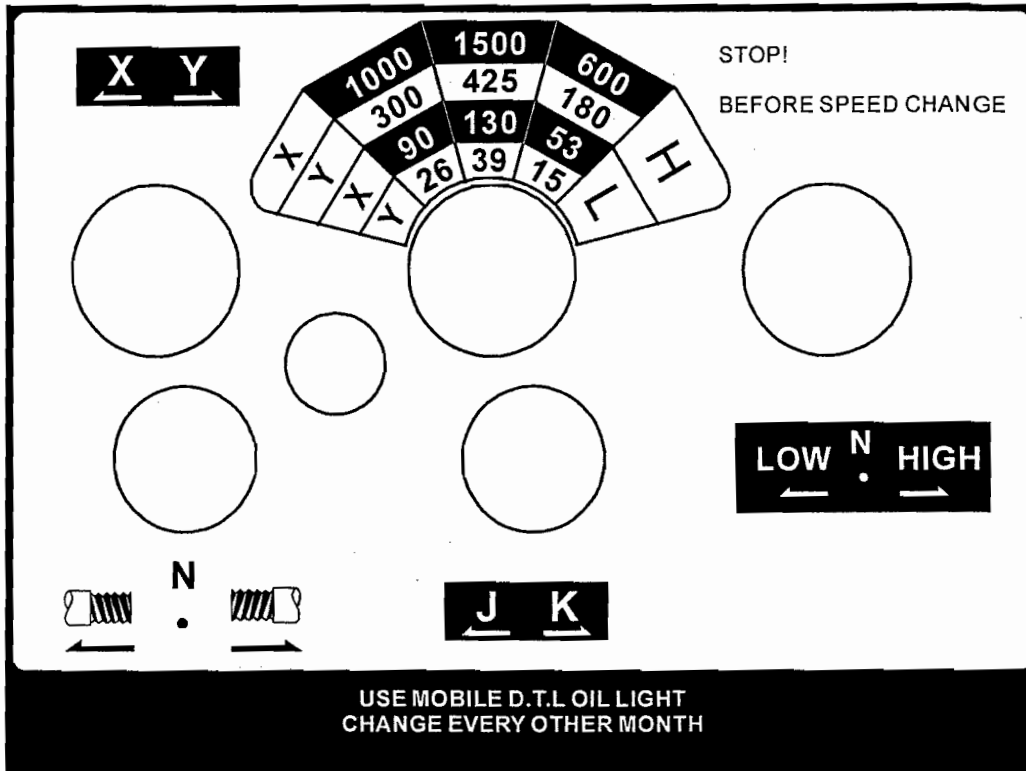

Fig.4-3

#### 4-4 Intermittent (Inching) Operation of Spindle

For the convenience of spindle speed shifting, feeding rate recognition and work piece center line and adjustment, press the intermittent button ⑨ located on the right side of the gear box, and the spindle will rotate forward. The spindle will rotate as long as the intermittent switch is pressed. The intermittent switch cannot rotate reverse.

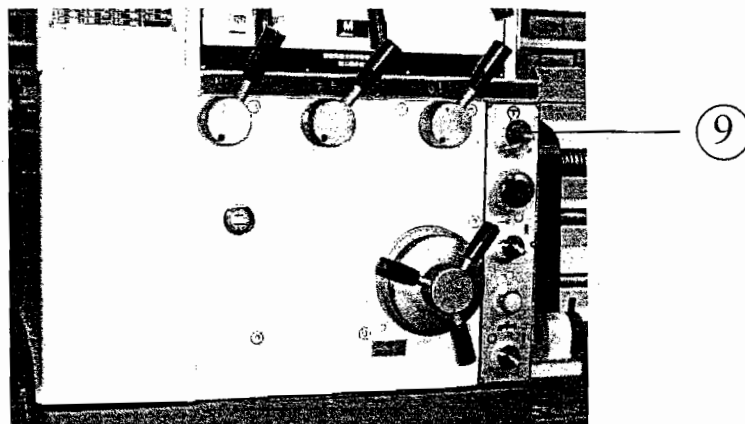

Fig.4-4

#### 4-5 The Importance and Methods of Spindle Leveling Adjustment

1. A lathe without proper leveling adjustment is likely to chatter. As a consequence, this will influence the cutting accuracy of work piece and result in poor roundness accuracy and finish. It is necessary to pay attention to the spindle leveling from time to time in order to have the best cutting condition of the lathe. Belt, 3-jaw chuck and the accumulative tolerances of parts on headstock, all such factors, can make the lathe chatter. To get rid of those problems, our lathe is especially designed to be equipped with leveling blocks mounted on the locking nut at the rear side of the spindle. The leveling blocks can be properly adjusted according to different condition. Please refer to following description & figure for proper adjustment.
2. Firstly, set up the spindle speed at 1350 rpm. Put the palm on left hand of the headstock cover and press the switch by left hand. Then switch on the lathe to make the spindle turn. Move the leveling block "A & C" left or right by hand feeling until obtain the best leveling position. Then also move the leveling block "B" left or right till the best position with same way. Adjust repeatedly till your hand feels no chattering. Afterwards, change the spindle speed to 2000rpm or 880rpm and check the leveling in the same way as we did at 1350rpm. Finally, for the leveling block set screw a, a', b.b. c.c. securely.

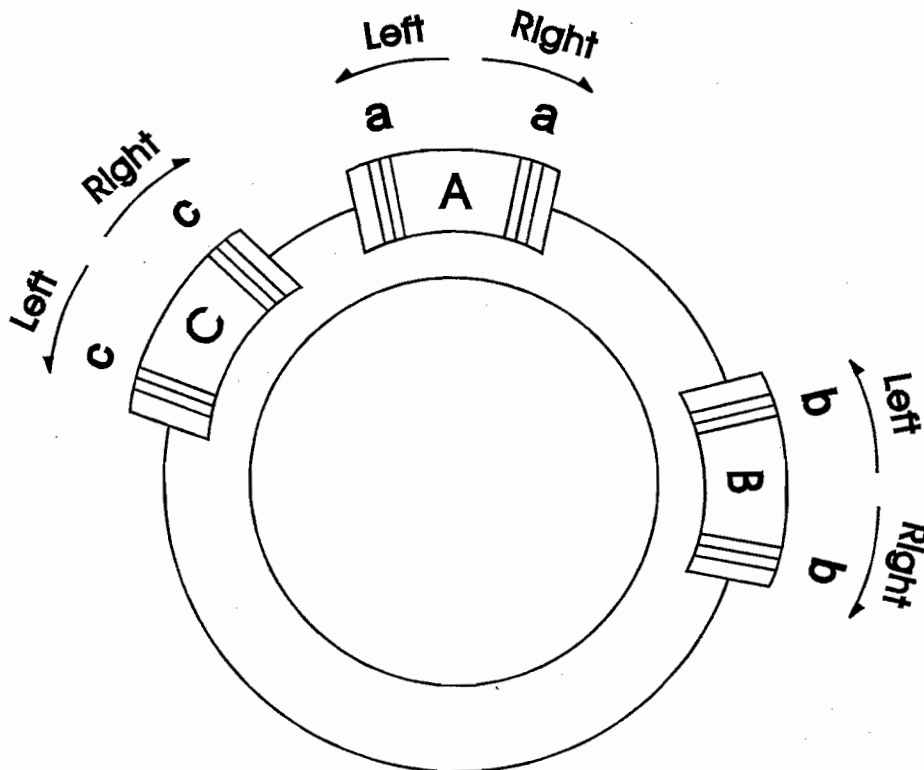

Fig.4-5

#### 4-6 Transmission & Stop of Gear Box

Open the end cover to find the gear train transmitting from headstock to gear box, position the forward/reverse shifting lever (④ of figure 1-1) to right side, the spindle will rotate forward; to right; reverse; to Neutral, stop. Do not change the gears while turning.

#### 4-7 Gear Box Operation

##### 1. Threading:

With the special design, there is no need to re-arrange the back gears for threading. Please refer to the 'threading & feeding table' and handle the thread/feed selection lever (⑤ of figure 1-1), thread, feed shifting lever (⑥ of figure 1-1) and 10-step feed selection dial (⑦ of figure 1-1) accordingly.

##### 2. Auto feeding

Also select the appropriate auto feeding rate by positioning the thread, feed selection lever (⑤ of figure 1-1), thread, feed shifting lever (⑥ of figure 1-1) and 10-step feed selection dial (⑦ of figure 1-1) as indicated on the 'threading and feeding table'.

#### 4-8 Manual Operation

First, position both the halt nut engage lever (⑬), and forward and reverse shifting lever (④ of figure 1-1) to 'N' position to operate the apron handwheel (⑬) cross slide handle (⑭), and compound rest handle (⑮) easily.

It feeds 17mm or 20mm (according to requirement) per revolution of apron handwheel. The dials on cross slide and compound rest is graduated 0.02mm per calibration, and feeds 5mm per revolution.

The tool post can be rotated clockwise after loosening the tool post clamping lever (⑯ of figure 1-1). Then position and tighten the clamping lever. For fixing the apron, just handle the saddle clamping lever (⑰). For cross slide and compound rest, screw tightly the set screws beside the taper pin.

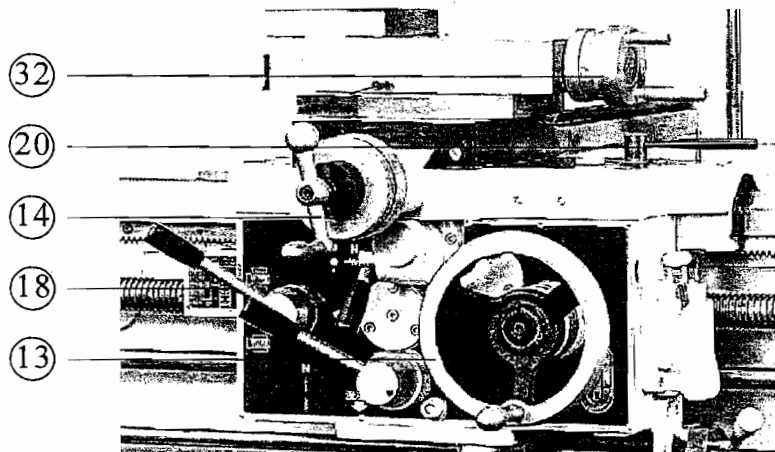

Fig. 4-8



#### 4-9 Automatic Feeding Operation

- (1) Position the thread/reverse shifting lever (④ of figure 1-1) for obtaining the required feeding position.
- (2) Shift the thread, feed selection lever (⑤ of figure 1-1), thread, feed selection lever (⑥ of figure 1-1), 10-step feed selection lever to select the appropriate feeding rate.
- (3) For threading, push the half nut engaged lever (⑱ of figure 1-1) downward till fully engaged.
- (4) For cross feeding, pull the feed axis selector (⑲ of figure 1-1) till full engaged.
- (5) For longitudinal feeding, push the feed axis selector downward.

#### 4-10 Automatic Feeding Stop Operation

The apron is equipped with automatic stop device. Tighten the screw on the top of the adjustable trip dog ⑫, and then fix it to the required position. Be careful that the top tip of the adjustable trip dog can be set onto the required position for forward and backward feeding. To avoid danger or damage to work piece, always have a test before starting.

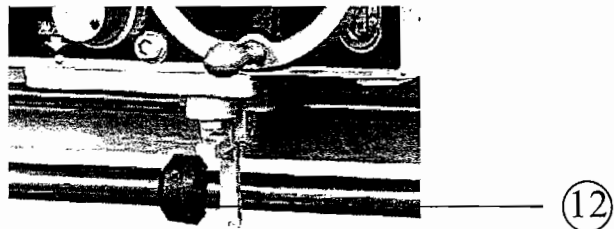

Fig.4-10

#### 4-11 4-position Automatic Feeding Stop Operation

To process certain length or step type of work piece, can use the 4-position Automatic feeding stop for length set cutting.

- (1) Rotate the adjustable trip dog (⑫ of figure 1-1) to the required setting position and make the top tip of the adjustable trip dog face outward. Try to test the auto feeding and adjust the front and back position of the adjustable trip dog if required, in order to ascertain the position setting accuracy.
- (2) Secondly, operate the 4-position automatic feed stop selection lever to the second adjustable trip dog by hand and fix the adjustable trip dog according to above procedure.
- (3) Same procedure for the third and fourth adjustable trip dog.
- (4) While the apron is auto-feeding, only the top tip of adjustable trip dog, which faces outward can touch the trip plunger (⑮ of figure 1-1). After stopping the auto feeding of apron, the other three adjustable trip dog can pass freely without any function.

#### 4-12 Tailstock Operation

- (1) The tailstock handwheel dial is divided 0.02mm per graduation. The tailstock moves forward 5mm per clockwise revolution of handwheel. When revolving clockwise, the quill will retract and , to the last, the center will release automatically.
- (2) Push the tailstock quill locking lever ⑩ forward to fix the tailstock quill. For fixing the tailstock onto the bedway, push tailstock body clamping lever ⑨ forward.
- (3) Adjust the centerline of the tailstock by loosening the tailstock set-over adjusting screw ⑥ on the side firstly, then adjust the screw on the other side. After adjustment, tighten the screw on both sides.

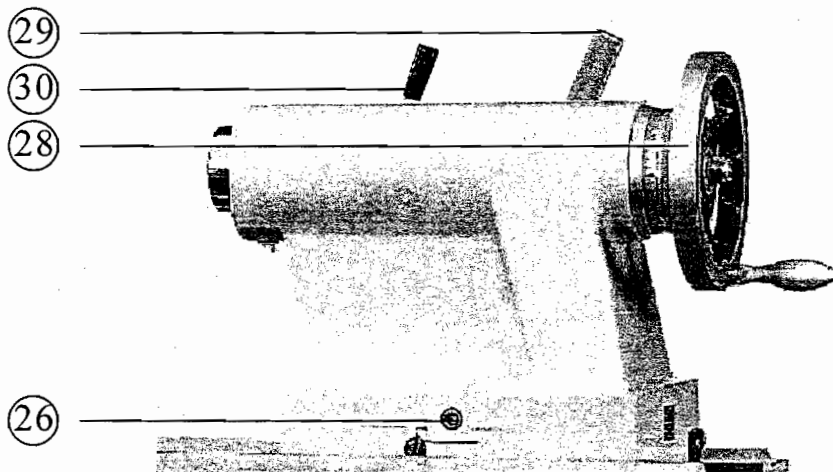
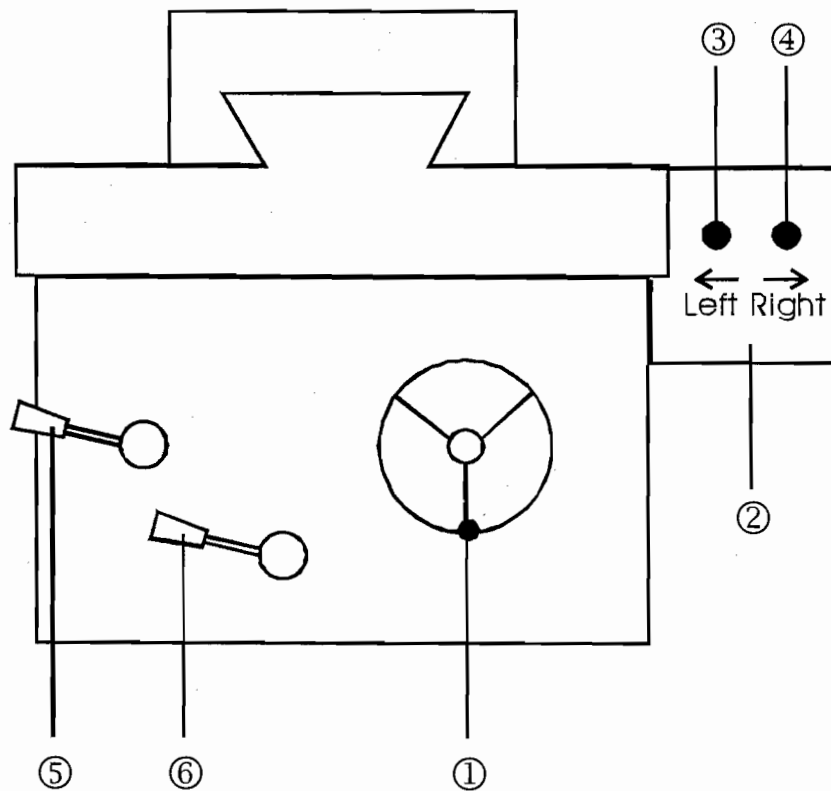

Fig.4-12

#### 4-13 Rapid Traverse Operation (Optional device)

1. When using rapid traverse, please keep ⑤ and ⑥ off.
2. To have safer operation, clutch ① must be off.
3. To make clutch come off, pull the hand wheel outward. Thus hand wheel does not rotate in high speed feeding, and does not injure the operator.
4. If it is necessary to feed by hand wheel, push the hand wheel inward. Meanwhile, turn the hand wheel counterclockwise to make the clutch engaged.
5. For rapid traverse toward right and left, buttons ③ and ④ are required.
6. Apron moves leftwards when button ③ is pressed, and stops when button ③ is released. Apron moves rightwards when button ④ is pressed, and stops when button ④ is released.



- ① Longitudinal feed hand wheel
- ② Rapid traverse control box
- ③ Rapid traverse button – left
- ④ Rapid traverse button – right
- ⑤ Half nut engaged lever
- ⑥ Auto feeding engaged lever

## 5. Threading

### 5-1 Leadscrew Drive

Move the forward/reverse lever (④ of figure 1-1) to the right will cause the leadscrew to rotate backwards, moving the lever to the left the leadscrew will rotate forward and when lever is in neutral the leadscrew will stop.

### 5-2 Threading

1. After selecting the thread to be cut, set the following levers to the appropriate position: ⑤, ⑥ & ⑦ of figure 1-1. (For example : if you want to tread 18 TPI, you need to set the levers to read as PAE2)
2. Turn off the lathe.
3. Engage the half nut by pushing ⑱ of figure 1-1 down, making sure it is fully engaged.

### 5-3 Thread Dial Indicator

1. Thread dial indicator for Imperial leadscrew

To cut even number threads the leadscrew can be engaged on any number of line. For odd number threads the leadscrew can be engaged on any number. Fractional threads (1/2, 1/4 etc.) leadscrew can only be engaged on the same number or line.

**Note:** When cutting metric threads on a lathe with an Imperial leadscrew be sure the half nut is engaged at all times (If not the thread will not repeat).

2. Thread dial indicator for Metric leadscrew cutting metric threads

There are two dials, 2&7 division and 3&5 division for Metric leadscrew while using Metric thread dial indicator. Use 3&5 division dial for cutting pitches 1.25, 2.5, 5.0, 2.25, 4.5; for the rest threads, use 2&7 division dial.



**Example1:** For cutting pitches 0.5, 0.75, 1.0, 1.5, 2.0, 3.0, 4.0, 6.0, use 14T worm gear and 2&7 division dial. The dial numbers at which the leadscrew nuts may be engaged are 7; that is, every division can be engaged by leadscrew nuts.

**Example2:** For cutting pitches 1.75, 3.5, 7.0 also use the same 14T worm gear and 2&7 division dial. But the dial numbers at which the leadscrew may be engaged on 2; number 1 and 2.



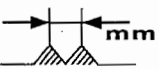

Gear teeth	Pitch		Dial division	Half nuts engaged number
11T	2.75	5.5	2	1
13T	3.25	6.5	2	1
14T	1.75	3.5	2	1,2
	7			
	0.5	0.75	7	1,2,3 4,5,6 7
	1	1.5		
	2	3		
	4	6		
15T	1.25	2.5	3	1,2,3
	5			
	2.25	4.5	5	1,2,3
18T	6.75		2	1,2

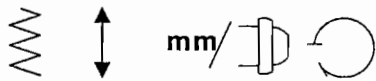
### 5-4 Thread & Feed Chart

For Swing 22", 26", 30" (560mm, 660mm, 760mm) Series while Metric Leadscrew & Metric Feed

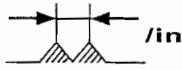
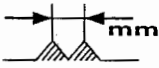
 <b>LEAD SCREW-P=6mm</b> R							
56	KAD10	27	KAE9	13	KAF8	5	KBF4
54	KAD9	26	KAE8	12	KAF7	4 1/2	KBF2
52	KAD8	24	KAE7	11 1/2	KAF6	4	KBF1
48	KAD7	23	KAE6	11	KAF5	3 1/2	JBF10
46	KAD6	22	KAE5	10	KAF4	3 1/4	JBF8
44	KAD5	20	KAE4	9 1/2	KAF3	3	JBF7
40	KAD4	19	KAE3	9	KAF2	2 7/8	JBF6
38	KAD3	18	KAE2	8	KAF1	2 3/4	JBF5
36	KAD2	16	KAE1	7	KBF10	2 1/2	JBF4
32	KAD1	14	KAF10	6	KBF7	2 1/4	JBF2
28	KAE10	13 1/2	KAF9	5 1/2	KBF5	2	JBF1
 <b>LEAD SCREW-P=6mm</b> C							
0.5	KSF1	2	KSD1	4.5	KUD2	9	JUD2
0.75	KSF7	2.25	KSD2	5	KUD4	10	JUD4
1	KSE1	2.5	KSD4	5.5	KUD5	11	JUD5
1.25	KSE4	3	KSD7	6	KUD7	12	JUD7
1.5	KSE7	3.5	KSD10	7	KUD10	13	JUD8
1.75	KSE10	4	KUD1	8	JUD1	14	JUD10
 C.T.				 C.T.			
0.05	KF1	0.30	KD4	0.02	KF1	0.15	KD5
0.06	KF2	0.34	KD5	0.03	KF3	0.17	KD7
0.08	KF5	0.37	KD7	0.04	KF7	0.20	KD10
0.10	KF10	0.42	KD10	0.05	KE1	0.24	JD2
0.13	KE2	0.48	JD1	0.06	KE3	0.27	JD4
0.17	KE5	0.54	JD2	0.07	KE5	0.30	JD5
0.21	KE10	0.60	JD4	0.08	KE7	0.34	JD7
0.24	KD1	0.74	JD7	0.1	KD1	0.40	JD10
0.27	KD2	0.82	JD10	0.12	KD2		

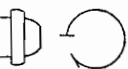
For Swing 22", 26", 30" (560mm, 660mm, 760mm) Series while Imperial Leadscrew & Imperial Feed

 <b>LEAD SCREW - 4TPI</b> R							
56	KAD10	27	KAE9	13	KAF8	5	KBF4
54	KAD9	26	KAE8	12	KAF7	4 1/2	KBF2
52	KAD8	24	KAE7	11 1/2	KAF6	4	KBF1
48	KAD7	23	KAE6	11	KAF5	3 1/2	JBF10
46	KAD6	22	KAE5	10	KAF4	3 1/4	JBF8
44	KAD5	20	KAE4	9 1/2	KAF3	3	JBF7
40	KAD4	19	KAE3	9	KAF2	2 7/8	JBF6
38	KAD3	18	KAE2	8	KAF1	2 3/4	JBF5
36	KAD2	16	KAE1	7	KBF10	2 1/2	JBF4
32	KAD1	14	KAF10	6	KBF7	2 1/4	JBF2
28	KAE10	13 1/2	KAF9	5 1/2	KBF5	2	JBF1
 <b>LEAD SCREW - 4TPI</b> C							
0.5	KSF1	2	KSD1	4.5	KUD2	9	JUD2
0.75	KSF7	2.25	KSD2	5	KUD4	10	JUD4
1	KSE1	2.5	KSD4	5.5	KUD5	11	JUD5
1.25	KSE4	3	KSD7	6	KUD7	12	JUD7
1.5	KSE7	3.5	KSD10	7	KUD10	13	JUD8
1.75	KSE10	4	KUD1	8	JUD1	14	JUD10
 in / 				 in / 			
C.T.				C.T.			
0.002	KF1	0.011	KD4	0.001	KF7	0.0043	KD8
0.0025	KF2	0.012	KD5	0.0012	KF10	0.0047	KD10
0.0031	KF5	0.014	KD7	0.0015	KE2	0.0052	JD1
0.0039	KF10	0.016	KD10	0.0017	KE4	0.0060	JD2
0.0051	KE2	0.018	JD1	0.002	KE7	0.0071	JD5
0.006	KE5	0.020	JD2	0.0023	KE10	0.0078	JD7
0.008	KE10	0.023	JD4	0.0026	KD1	0.0086	JD8
0.009	KD1	0.027	JD7	0.0030	KD2	0.0094	JD10
0.010	KD2	0.032	JD10	0.0036	KD5		

For Swing 22", 26", 30" (560mm, 660mm, 760mm) Series while Imperial Leadscrew but Metric Feed

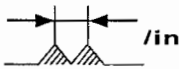
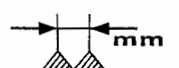
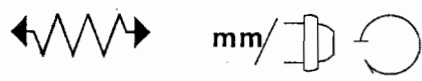
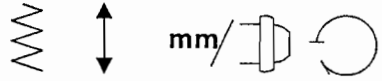
 <b>LEAD SCREW – 4TPI</b> R							
56	KAD10	27	KAE9	13	KAF8	5	KBF4
54	KAD9	26	KAE8	12	KAF7	4 1/2	KBF2
52	KAD8	24	KAE7	11 1/2	KAF6	4	KBF1
48	KAD7	23	KAE6	11	KAF5	3 1/2	JBF10
46	KAD6	22	KAE5	10	KAF4	3 1/4	JBF8
44	KAD5	20	KAE4	9 1/2	KAF3	3	JBF7
40	KAD4	19	KAE3	9	KAF2	2 7/8	JBF6
38	KAD3	18	KAE2	8	KAF1	2 3/4	JBF5
36	KAD2	16	KAE1	7	KBF10	2 1/2	JBF4
32	KAD1	14	KAF10	6	KBF7	2 1/4	JBF2
28	KAE10	13 1/2	KAF9	5 1/2	KBF5	2	JBF1
 <b>LEAD SCREW – 4TPI</b> C							
0.5	KSF1	2	KSD1	4.5	KUD2	9	JUD2
0.75	KSF7	2.25	KSD2	5	KUD4	10	JUD4
1	KSE1	2.5	KSD4	5.5	KUD5	11	JUD5
1.25	KSE4	3	KSD7	6	KUD7	12	JUD7
1.5	KSE7	3.5	KSD10	7	KUD10	13	JUD8
1.75	KSE10	4	KUD1	8	JUD1	14	JUD10
 mm/				 mm/			
C.T.				C.T.			
0.05	KF1	0.29	KD4	0.02	KF1	0.14	KD5
0.06	KF2	0.32	KD5	0.03	KF3	0.16	KD7
0.08	KF5	0.35	KD7	0.04	KF7	0.18	KD10
0.10	KF10	0.40	KD10	0.05	KE1	0.20	JD1
0.13	KE2	0.45	JD1	0.06	KE3	0.24	JD2
0.16	KE5	0.52	JD2	0.07	KE5	0.28	JD5
0.20	KE10	0.58	JD4	0.08	KE7	0.32	JD7
0.23	KD1	0.70	JD7	0.1	KD1	0.36	JD10
0.26	KD2	0.80	JD10	0.12	KD2		



5-5 Module & D.P Thread Chart

For Swing 22", 26", 30" (560mm, 660mm, 760mm) Series while Metric Leadscrew

	LEAD SCREW-P=6mm							
	 $\pi/1"$				R			
	56	KAD10	27	KAE9	13	KAF8	5	KBF4
	54	KAD9	26	KAE8	12	KAF7	4 1/2	KBF2
	52	KAD8	24	KAE7	11 1/2	KAF6	4	KBF1
	48	KAD7	23	KAE6	11	KAF5	3 1/2	JBF10
	46	KAD6	22	KAE5	10	KAF4	3 1/4	JBF8
	44	KAD5	20	KAE4	9 1/2	KAF3	3	JBF7
	40	KAD4	19	KAE3	9	KAF2	2 7/8	JBF6
	38	KAD3	18	KAE2	8	KAF1	2 3/4	JBF5
	36	KAD2	16	KAE1	7	KBF10	2 1/2	JBF4
	32	KAD1	14	KAF10	6	KBF7	2 1/4	JBF2
	28	KAE10	13 1/2	KAF9	5 1/2	KBF5	2	JBF1
	LEAD SCREW-P=6mm							
	 $mm/\pi$				C			
	0.5	KSF1	2	KSD1	4.5	KUD2	9	JUD2
	0.75	KSF7	2.25	KSD2	5	KUD4	10	JUD4
	1	KSE1	2.5	KSD4	5.5	KUD5	11	JUD5
	1.25	KSE4	3	KSD7	6	KUD7	12	JUD7
	1.5	KSE7	3.5	KSD10	7	KUD10	13	JUD8
1.75	KSE10	4	KUD1	8	JUD1	14	JUD10	

For Swing 22", 26", 30" (560mm, 660mm, 760mm) Series while Imperial Leadscrew

	<b>LEAD SCREW – 4TPI</b>							
					<b>R</b>			
	56	KAD10	27	KAE9	13	KAF8	5	KBF4
	54	KAD9	26	KAE8	12	KAF7	4 1/2	KBF2
	52	KAD8	24	KAE7	11 1/2	KAF6	4	KBF1
	48	KAD7	23	KAE6	11	KAF5	3 1/2	JBF10
	46	KAD6	22	KAE5	10	KAF4	3 1/4	JBF8
	44	KAD5	20	KAE4	9 1/2	KAF3	3	JBF7
	40	KAD4	19	KAE3	9	KAF2	2 7/8	JBF6
	38	KAD3	18	KAE2	8	KAF1	2 3/4	JBF5
	36	KAD2	16	KAE1	7	KBF10	2 1/2	JBF4
	32	KAD1	14	KAF10	6	KBF7	2 1/4	JBF2
	28	KAE10	13 1/2	KAF9	5 1/2	KBF5	2	JBF1
	<b>LEAD SCREW – 4TPI</b>							
					<b>C</b>			
0.5	KSF1	2	KSD1	4.5	KUD2	9	JUD2	
0.75	KSF7	2.25	KSD2	5	KUD4	10	JUD4	
1	KSE1	2.5	KSD4	5.5	KUD5	11	JUD5	
1.25	KSE4	3	KSD7	6	KUD7	12	JUD7	
1.5	KSE7	3.5	KSD10	7	KUD10	13	JUD8	
1.75	KSE10	4	KUD1	8	JUD1	14	JUD10	

## 6. LUBRICATION

### 6-1 Headstock Lubrication

Headstock lubrication is splash injection type. Oil grooves are equipped around the headstock to provide lubricant flowing from oil grooves to spindle, then finally reach the bottom of the headstock. To add oil, take off the oil plug on the top of the headstock cover, fill to the centerline of oil sight glass. Oil drain hole is located on the right bottom side of the headstock.

Before operating the lathe, be sure the headstock is filled with oil. If not, add Shell Tellus #32. Exchange oil after one month use for the first time. Thereafter every three months.

### 6-2 Gear Box & Apron Lubrication

1. Gear box is reservoir oil bath type. To ensure the long service life of gear box and bedways, exchange the oil of gear box every six months.
2. Apron is also reservoir oil bath type. Add the oil as soon as the oil is lower than the center line of the oil sight glass.

### 6-3 Lubrication Charts

No.	Location	Methods	Oil amount	Oil time	Exchange time	Recommend oil type
1	Headstock	Loosen the oil input hole screw on the left top side of the headstock cover	Center-line		One month at the beginning, thereafter once three months	Shell Tellus #32
2	Gear Box	Open the top cover and loosen the oil input hole screw.	Center-line		Every six months	Shell Tellus Omala 150
3	Apron	Loosen the oil input hole screw	Center-line	Once per day		Shell Tellus T-68
4	Compound rest	Add oil with oil gun	As required	Once per day		
5	Auto Feeding rod	Add oil with oil gun	As required	Once per day		
6	Tailstock	Add oil with oil gun	As required	Once per day		
7	Leadscrew	Add oil with oil gun	As required	Once per day		
8	Bedway	Auto lubrication				

# 9-1 HEADSTOCK

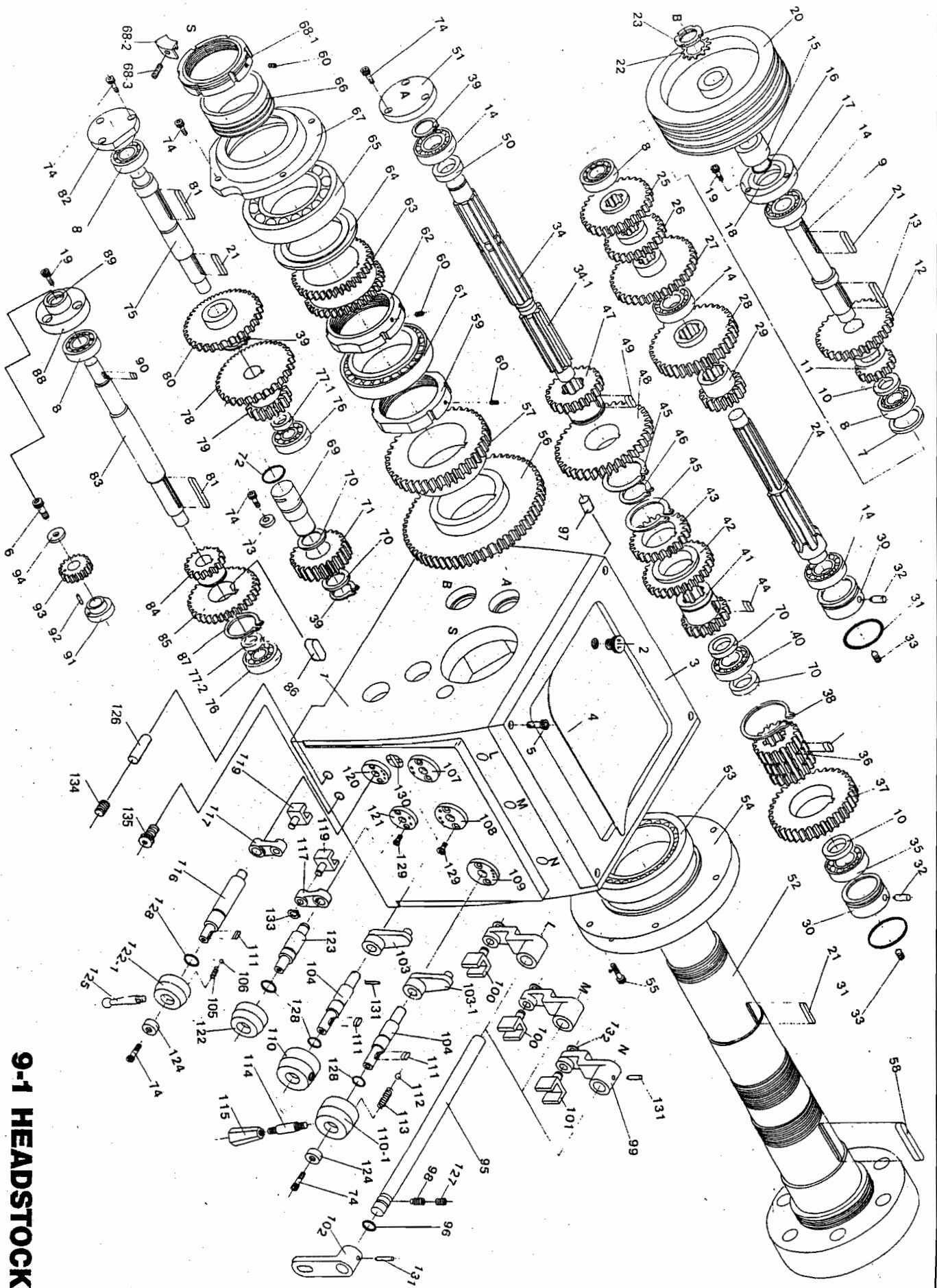

- 1 HEADSTOCK
- 2 GEAR BOX
- 3 APRON
- 4 BED AND BASE
- 5 BRAKE SYSTEM
- 6 CARRIAGE AND CROSSFEED
- 6A CARRIAGE AND CROSSFEED
- 7 TAILSTOCK

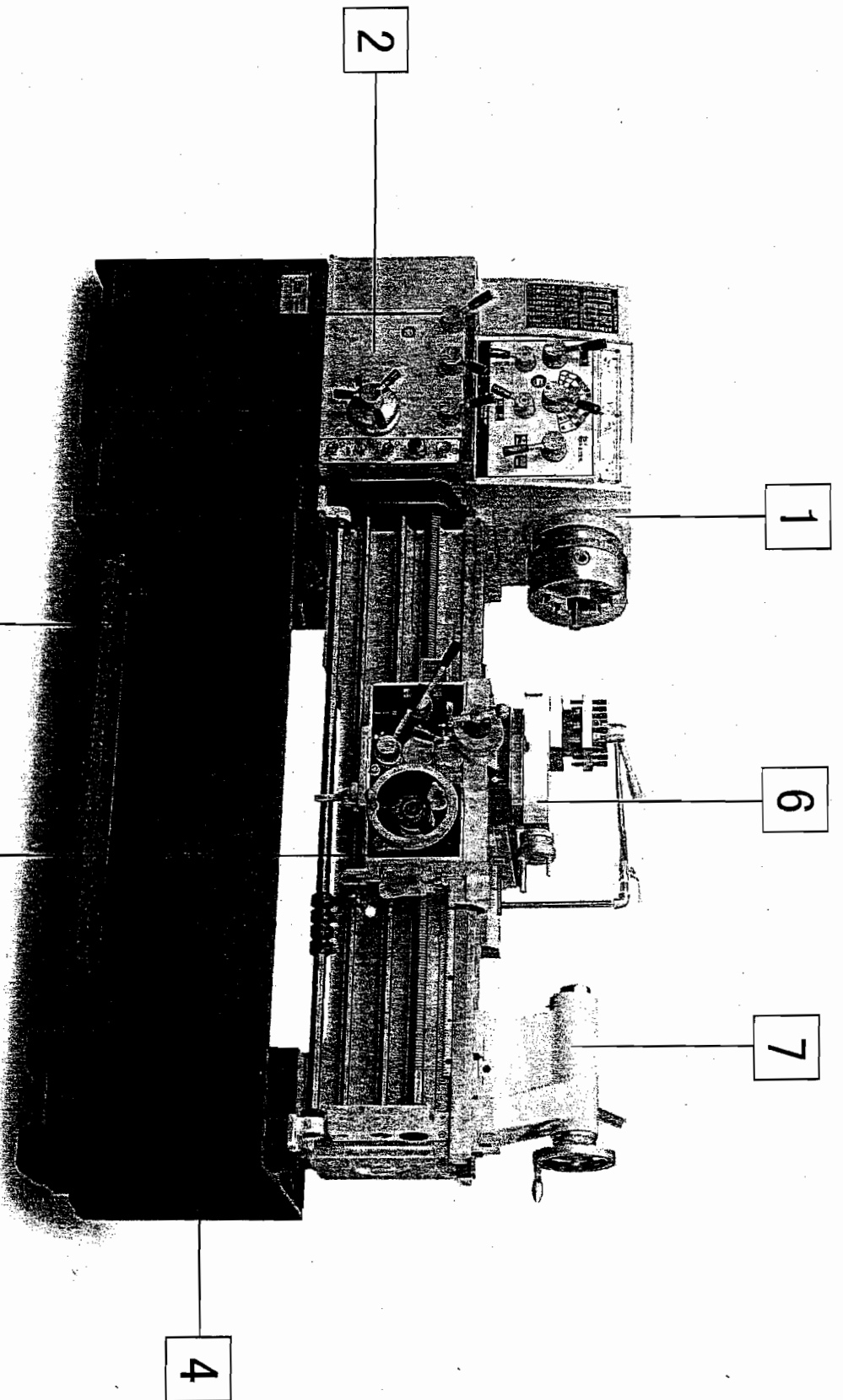

**SYSTEM IN EACH UNIT**

## 7-2 Apron & Saddle

1. Apron lubrication location: on the right top side of the saddle base, the oil inlet plug marked "OIL" is the oil inlet hole.
2. Apron drain hole located on the bottom cover of the apron as shown on the right side figure, the drain plug marked (A) (also see the chart on the front bottom side of the apron).
3. Oil brand and oil exchange time: Use Shell Tellus T-68 and exchange the oil half a year.
4. To adjust the half nut engaged lever: After long use, the lever may be loosened and needed to be adjusted. First, take off the thread dial indicator and find the 4 gib strip adjusting screws. Second, while pressing the lever, also adjust the 4 gib strip adjusting screws until they are properly tightened. Afterwards, replace the thread dial indicator.
5. To clear up and repair the manual pump being blocked or small oil flow: If no oil oozes out after pushing the manual pump several times, the pump is blocked. Take off the 4 setscrews of the pump body and loosen the plug lever to dismantle the set nut. Use air gun to clean up the inside of the blocked pump. If the oil flow is too small, it must be the O-ring worn out, replace another new O-ring and assemble back the dismantled parts accordingly.
6. Adjustment for the longitudinal & cross auto feeding overload: The cone clutch on the center of the apron is an overload device. The safety overload weight limitation is 12 kgs. Overload weight can be adjusted by means of the Hexagon screw on the center of the apron; tighten clockwise, the overload will increase; tighten anticlockwise, the overload will then decrease. When auto-feeding, press the handwheel by hand, it should automatically slip out if the overload is over 12 kgs. If not, adjust again.

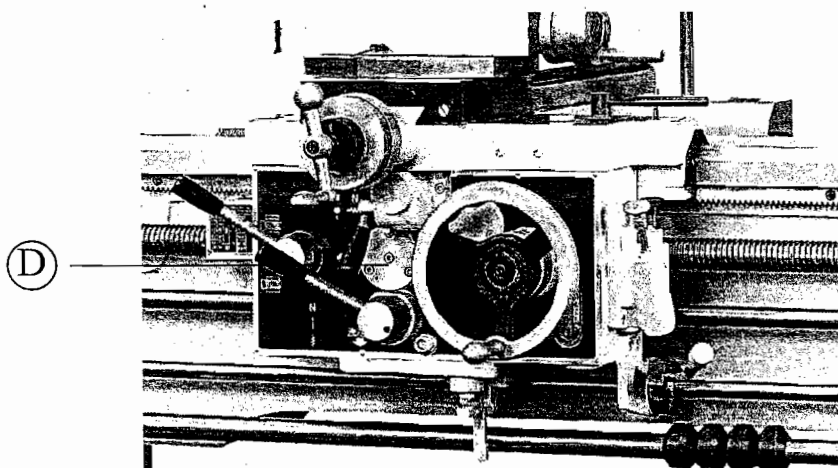
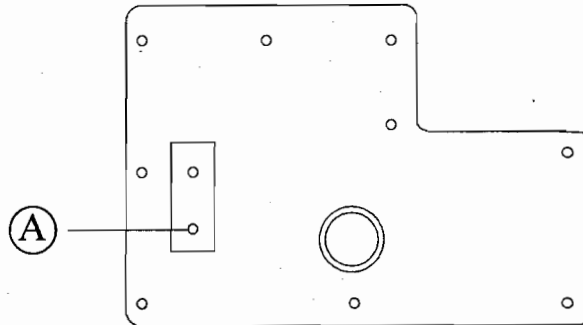

Fig.7-2

### 7-3 Gear Box

1. Lubrication location: Below the top cover of the apron, take off the top cover to find the oil plug marked "OIL", the oil inlet hole.
2. Drain hole: On the left bottom side of the 10-step feed selection dial. The screw with hexagon nut is the oil drain hole as arrow ② shown on figure 7-3.
3. Oil brand and oil exchange time: Use Shell Tellus Omala 150 and exchange the oil half a year.

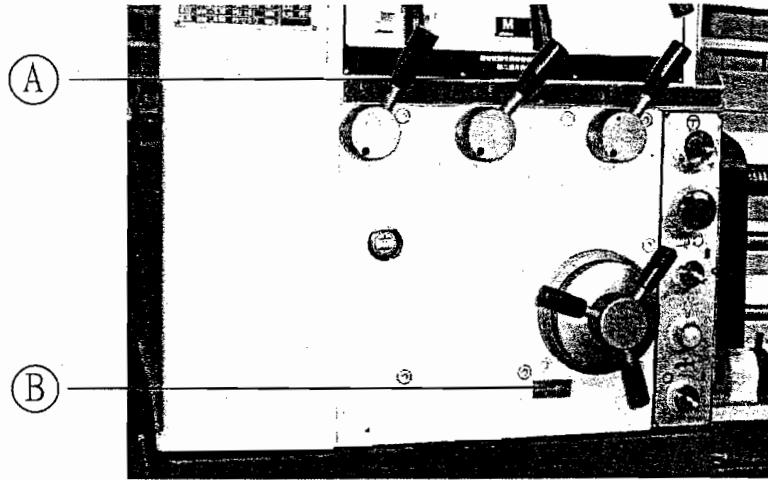

Fig. 7-3

### 7-4 Tailstock Center Line Adjustment

First, unclamp the tailstock body clamping lever, and then loosen the 2 hexagon head screw on both right and left sides which lock the tailstock body and base together. Determine the direction and amount of the misalignment for adjustment by positioning a test bar between two dead centers. Slacken the rear 'location screw' (say one half turn). Then alternatively slacken one set-over screw and tighten the other until the required setting is achieved, (correct alignment). Carefully retighten the rear 'location screw' and the set over screw which was slackened before and recheck alignment. Retighten the two hexagon head screw carefully and re-clamp the tailstock (figure 7-4)

If still can not operate the handwheel easily after the tailstock quill is fixed, it is caused by the reason that the clamping block can not be loosened. To solve it, just push the tailstock body clamping lever forward one time for recovering.

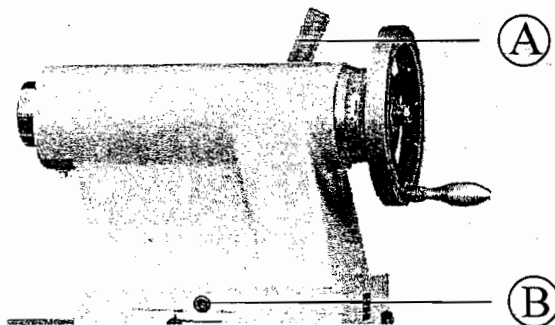

Fig. 7-4

## 7-5 Belt Tension Adjustment

After long use, the belt will stretch and require periodic tension adjustment.

1. Take off the cover on the left back side of the lathe.
2. Loosen adjusting nut ① and lower down the suitable height until the desired belt tension is achieved.
3. After adjustment, be sure to tighten the adjusting nut securely.

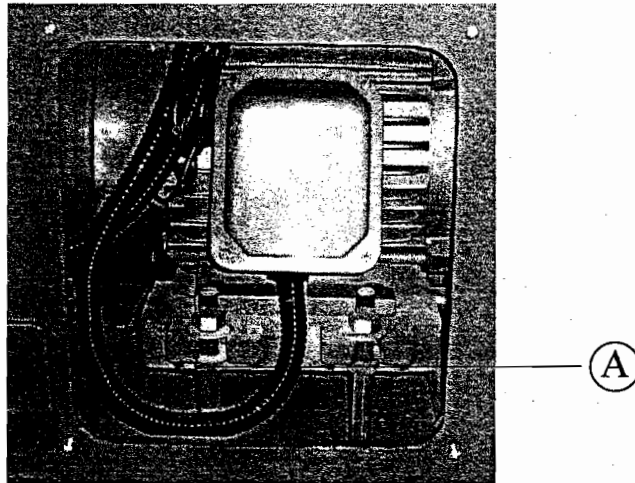

Fig 7-5

## 7-6 Brake Belt Adjustment

If the brake belt is worn out and cause the brake band tool loosen, it is time to adjust the nut ② of the brake band. Remove the side rear cover, loosen the nuts on the top firstly and tighten the nuts on the bottom to the appropriate height. Then tighten the nuts on the top to complete the adjustment. After adjustment, replace the side rear cover.

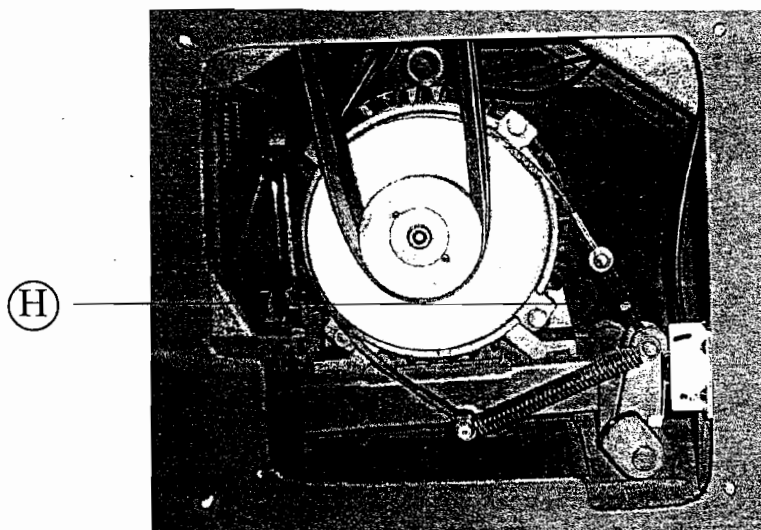

Fig 7-6



### 7-7 Brake & Micro Switch Adjustment

The foot brake is connected with the micro switch. It should have 0-1mm end play between the brake arm and the touching, head of the micro switch. The correct brake action should cut off the electricity first, then brake to avoid the brake belt being worn out. After stepping the foot brake, needs to re-operate the spindle operation control lever to make the spindle revolute again.

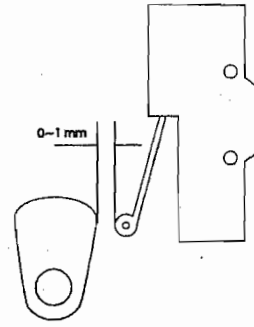

Fig. 7-7

### 7-8 Leadscrew Backlash Adjustment

If multiple cutting is happened while threading, it is caused by the leadscrew backlash. To adjust the leadscrew half nut properly, open the plastic cover of the leadscrew bracket and loosen nut (A). Then tighten the left side nut (B) until there is no backlash. (For testing, press down the half nut by hand, turn the apron handwheel forward and reverse and grasp the connecting section of the gear box and leadscrew till no backlash happened.) Afterwards, replace the nut (A) to the leadscrew bracket.

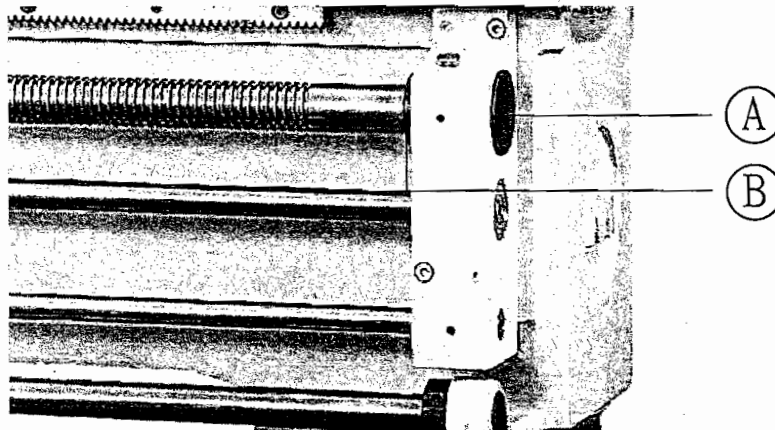

Fig. 7-8

### 7-9 Cutting Coolant Repair

If there is no coolant coming out after the pump switch is turned on, check the pump motor is working or not. If yes, check and see if the coolant in the tank is over the pump or not, If not, add the coolant, then turn on the switch, If there is still no coolant, the pump must be blocked. Take off the pump to clean up or repair.

## **PART LISTS**

### **9 SYSTEM IN EACH UNIT**

**9-1 HEADSTOCK : Ø85mm or Ø115mm**

**9-2 GEAR BOX**

**9-3 APRON**

**9-4 BED AND BASE**

**9-5 BRAKE SYSTEM**

**9-6 CARRIAGE AND CROSSFEED (For Taiwan market only)**

**9-6A CARRIAGE AND CROSSFEED (For markets out of Taiwan)**

**9-7 TAILSTOCK ASSEMBLY**

**9-8 STEADY REST ASSEMBLY**

**9-9 FOLLOW REST ASSEMBLY**

**9-10 COOLANT SYSTEM ASSEMBLY**

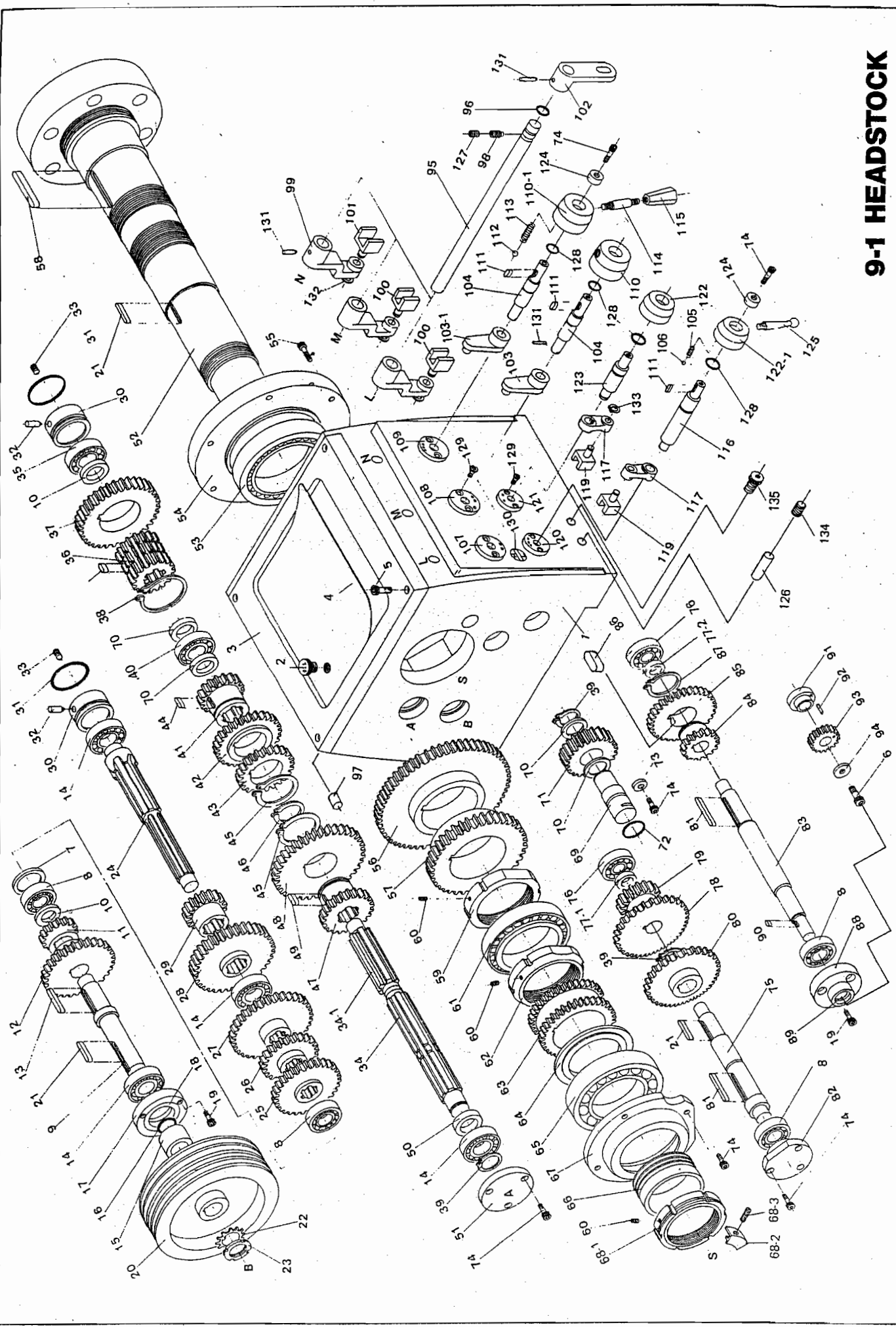

9-1 HEADSTOCK

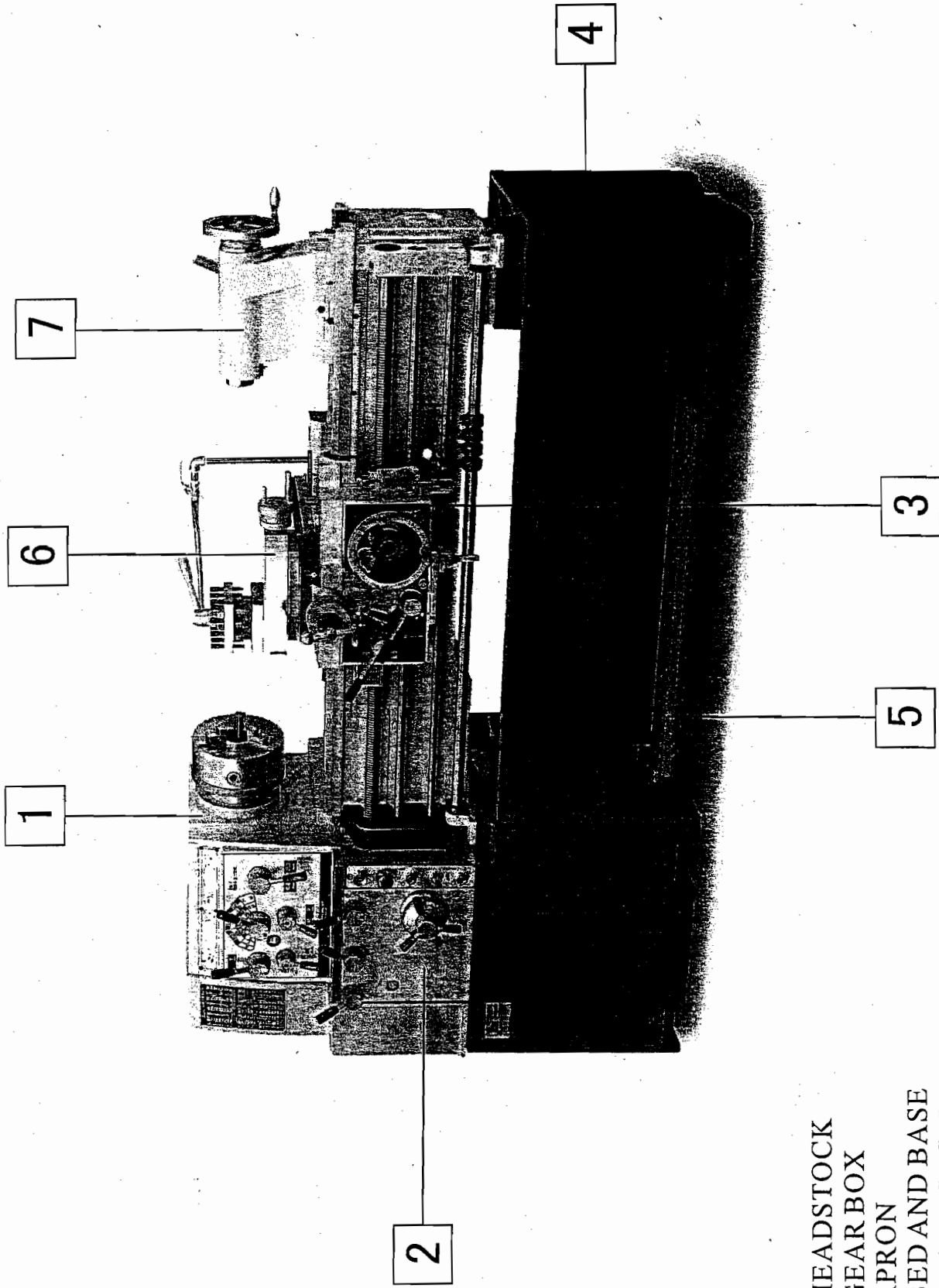

- 1 HEADSTOCK
- 2 GEAR BOX
- 3 APRON
- 4 BED AND BASE
- 5 BRAKE SYSTEM
- 6 CARRIAGE AND CROSSFEED
- 6A CARRIAGE AND CROSSFEED
- 7 TAILSTOCK

## SYSTEM IN EACH UNIT

## HEADSTOCK ASSMBLY (Spindle Bore : 85mm or 3")

ITEM NO.	Part Name	Amt. Used	Type: 22 Part No.	Type: 26 Part No.	Type: 2680 Part No.	Type: 3080 Part No.
1	Head stock	1			4001001-263	4001001-303
2	Oil plug	1	1122103405	1122103405	1122103405	1122103405
3	Head stock cover	1	1360200505	1360200505	1440200305	1440200305
4	Blanket	1	1003509403	1003509403	4001004	4001004
5	Hexagon socket screw, M8xP1.25x35L	4				
7	Spacer	1	1360207800	1360207800	1440201606	1440201606
8	Ball-bearing, 6205	1	91301020	91301020	91301020	91301020
9	Input-shaft	1	1360200603	1360200603	1440200403	1440200403
10	Spacer	2	1360206605	1360206605	1360206605	1360206605
11	Gear- i (20T)	1	1360200701	1360200701	1360200701	1360200701
12	Gear- g (41T)	1	1360200809	1360200809	1360200809	1360200809
13	Square key, 8x7x55L	1				
14	Ball-bearing, 6206	5	91301021	91301021	91301021	91301021
17	Housing	1	1120206903	1120206903	1120206903	1120206903
18	Oil-seal, TC30x50x8L	1				
19	Hexagon socket screw, M6xP1.0x20L	6				
20	Pulley wheel	1	3501020	3501020	3501020	3501020
21	Square key, 8x7x45L	3				
22	Spring-washer M12	1				
23	Screw , M12x30	1				
24	Shaft-B	1	1360202509	1360202509	1440200609	1440200609
25	Gear- d (39T)	1	1360200907	1360200907	1360200907	1360200907
26	Gear- b (32T)	1	1360201002	1360201002	1360201002	1360201002
27	Gear- f (48T)	1	1360201100	1360201100	1360201100	1360201100
28	Gear- k (46T)	1	1360201208	1360201208	1360201208	1360201208
29	Gear- o (22T)	1	1360201306	1360201306	1360201306	1360201306
30	Plug-cover	2	1360202901	1360202901	1360202901	1360202901
31	O-ring, P55x3.5	2				
32	Fixed pin	2	1120206707	1120206707	1120206707	1120206707
33	Set screw	2				
34	Shaft-A	1	1360202607	1360202607	1440200707	1440200707
34-1	Shaft-L	1	1360202705	1360202705	1440200805	1440200805
35	Ball-bearing, 6305	1	91301029	91301029	91301029	91301029
36	Gear- l (25T)	1	1360201404	1360201404	1360201404	1360201404
36-1	Square key, 7x10x18L	2				
37	Gear- m	1	1360206703	1360206703	1360206703	1360206703
38	Snap ring, S75	2				
39	Snap ring, S30	3				
40	Ball-bearing, 6006	2	91301013	91301013	91301013	91301013
41	Gear- e	1	1360201502	1360201502	1360201502	1360201502
42	Gear- a	1	1440202407	1440202407	1440202407	1440202407
43	Gear- c	1	1440202505	1440202505	1440202505	1440202505
44	Square key, 8x7x30L	1				
45	Snap ring, S55	2				
46	Snap ring, S38	2				
47	Gear- h (30T)	1	1360201600	1360201600	1360201600	1360201600
48	Gear- j (51T)	1	1360207504	1360207504	1360207504	1360207504
49	Square key, 8x7x25L	1				

## HEADSTOCK ASSMBLY (Spindle Bore : 85mm or 3")

ITEM NO.	Part Name	Amt. Used	Type: 22 Part No.	Type: 26 Part No.	Type: 2680 Part No.	Type: 3080 Part No.
50	Spacer	1	1360206801	1360206801	1360206801	1360206801
51	Cover	1	1360203104	1360203104	1360203104	1360203104
52	Spindle (A1-8)	1	136020031	136020031	1440200109	1440200109
	(D1-8)	1	1360200407	1360200407	1440200207	1440200207
53	Taper roller bearing, 32024	1	91302016	91302016	91302016	91302016
54	Cover (A1-8)	1	136020011	136020011	136020011	136020011
	(D1-8)	1	136020021	136020021	136020021	136020021
55	Hexagon socket screw, M6xP1.0x20L	6				
56	Gear- p (78T)	1	1360201708	1360201708	1360201708	1360201708
57	Gear- n (55T)	1	1360201806	1360201806	1360201806	1360201806
58	Square key, 10x8x85L	1				
59	Lock-nut	1	1360203202	1360203202	1360203202	1360203202
60	Set screw, M8xP1.25x8L	5				
61	Taper roller bearing, 32021	1	91302015	91302015	91302015	91302015
62	Lock-nut	1	1360203300	1360203300	1360203300	1360203300
63	Gear (48T)	1	1360201904	1360201904	1360201904	1360201904
64	Collar	1	1360203408	1360203408	1360203408	1360203408
65	Ball-bearing, 6020	1	91301034	91301034	91301034	91301034
66	Oil return collar	1	1360203506	1360203506	1360203506	1360203506
67	Cover	1	1360203604	1360203604	1360203604	1360203604
68-1	Lock-nut	1	1360203702	1360203702	1360203702	1360203702
68-2	Balance piece	3	1360203800	1360203800	1360203800	1360203800
68-3	Set screw	6				
69	Idle gear shaft	1	1120207508	1120207508	1120207508	1120207508
70	Spacer	4	1120206609	1120206609	1120206609	1120206609
71	Idle gear (32T)	1	1360202009	1360202009	1360202009	1360202009
72	O-ring, P29	1				
73	Washer	1	112020761	112020761	112020761	112020761
74	Hexagon socket screw, M6xP1.0x16L	16				
75	Shaft-c	1	1360202107	1360202107	1440200501	1440200501
76	Ball-bearing, 6304	2	91301028	91301028	91301028	91301028
77-1	Spacer	1	1360206909	1360206909	1360206909	1360206909
77-2	Spacer	1	1360207004	1360207004	1360207004	1360207004
78	Gear	1	1360207406	1360207406	1360207406	1360207406
79	Gear (22T)	1	1360202205	1360202205	1360202205	1360202205
80	Gear (48T)	1	1360202303	1360202303	1360202303	1360202303
81	Square key, 8x7x65L	2				
82	Cover	1	1360203908	1360203908	1360203908	1360203908
83	Shaft-D	1	1360202803	1360202803	1360202803	1360202803
84	Gear (33T)	1	1360202401	1360202401	1360202401	1360202401
85	Gear (44T)	1	1440202309	1440202309	1440202309	1440202309
86	Square key, 8x7x20L	1				
87	Snap ring, S45	1				
88	Housing	1	1360204003	1360204003	1360204003	1360204003
89	Seal-oil, TC25x47x8L	1				
90	Square key, 6x6x12L	1				
91	Collar	1	1121602203	1121602203	1121602203	1121602203
92	Taper pin, O # x25L	1				

## HEADSTOCK ASSMBLY (Spindle Bore : 85mm or 3")

ITEM NO.	Part Name	Amt. Used	Type: 22 Part No.	Type: 26 Part No.	Type: 2680 Part No.	Type: 3080 Part No.
93	Gear (in)	1	1121600405	1121600405	1121600405	1121600405
	Gear (mm)	1	1121600307	1121600307	1121600307	1121600307
94	Washer	1				
95	Shifting shaft	3	1360204101	1360204101	1360204101	1360204101
96	O-ring, P16	6				
97	Plug	3	1120207704	1120207704	1120207704	1120207704
98	Set screw	3	1360204209	1360204209	1360204209	1360204209
99	Shifting lever	3	1360204307	1360204307	1360204307	1360204307
100	Shifting fork	1	112020781	112020781	112020781	112020781
		1	112020791	112020791	112020791	112020791
101	Shifting fork	1	136020441	136020441	136020441	136020441
102	Shifting lever	3	1360204503	1360204503	1360204503	1360204503
103	Shifting lever	3	1360204601	1360204601	1360204601	1360204601
104	Shaft	3	1360204709	1360204709	1360204709	1360204709
105	Spring, D6xd0.8x25L	2				
106	Ball steel , $\phi$ 1/4"	2				
107	Detent plate	1	1360204905	1360204905	1360204905	1360204905
108	Detent plate	1	1360205000	1360205000	1360205000	1360205000
109	Detent plate	1	1360205108	1360205108	1360205108	1360205108
110	Hub	2	1360205206	1360205206	1360205206	1360205206
110-1	Hub		1360205304	1360205304	1360205304	1360205304
111	Square key, 5x5x15L	3				
112	Ball steel , $\phi$ 5/16"	3				
113	Spring, D8xd0.8x25L	1				
	Spring, D8xd1.1x29L	2				
114	Lever	3	1120207302	1120207302	1120207302	1120207302
115	Knob	3	1120207400	1120207400	1120207400	1120207400
116	Shaft	1	1360207200	1360207200	1440201302	1440201302
117	Shifting lever	2	1360205402	1360205402	1360205402	1360205402
119	Shifting fork	2	133020011	133020011	133020011	133020011
120	Detent plate	1	1360205608	1360205608	1360205608	1360205608
121	Detent plate	1	1360205706	1360205706	1360205706	1360205706
122	Knob	1	1360205804	1360205804	1360205804	1360205804
122-1	Knob	1	1360205902	1360205902	1360205902	1360205902
123	Shaft	1	1360207308	1360207308	1360207308	1360207308
124	Washer	5	1120206109	1120206109	1120206109	1120206109
125	Lever	2	1120207204	1120207204	1120207204	1120207204
126	Pin	2	1361600107	1361600107	1361600107	1361600107
127	Set screw, M8xP1.25x8L	3				
128	O-ring , P18	5				
129	Screw , M6xP1.0x14L	10				
130	Lenz-oil , $\phi$ 29	1	92552001	92552001	92552001	92552001
131	Spring pin , $\phi$ 5x30L	9				
132	Snap ring, S12	3				
133	Snap ring, S10	2				
134	Set screw, M12xP1.75x20L	2				
135	Hexagon socket screw, M8xP1.25x35L	2				

## HEADSTOCK ASSMBLY (Spindle Bore : 115mm or 4")

ITEM NO.	Part Name	Amt. Used	Type: 22 Part No.	Type: 26 Part No.	Type: 30 Part No.	名稱
1	Head stock	1	401001-224	401001-264	401001-304	主軸箱本體
2	Oil plug	1	1122103405	1122103405	1122103405	油塞
3	Head stock cover	1	1440200305	1440200305	1440200305	主軸箱蓋
4	Blanket	1	4001004	4001004	4001004	主軸箱蓋塑膠皮
5	Hexagon socket screw, M8xP1.25x35L	4				六角承窩螺絲
7	Spacer	1	1440201606	1440201606	1440201606	間隔圈
8	Ball-bearing, 6205	1	91301020	91301020	91301020	滾珠軸承
9	Input-shaft	1	1440200403	1440200403	1440200403	輸入軸
10	Spacer	2	1360206605	1360206605	1360206605	間隔圈
11	Gear- i (20T)	1	1360200701	1360200701	1360200701	齒輪
12	Gear- g (41T)	1	1360200809	1360200809	1360200809	齒輪
13	Square key, 8x7x55L	1				雙圓平行鍵
14	Ball-bearing, 6206	5	91301021	91301021	91301021	滾珠軸承
17	Housing	1	112020691	112020691	112020691	軸承蓋
18	Oil-seal, TC30x50x8L	1				油封
19	Hexagon socket screw, M6xP1.0x20L	6				六角承窩螺絲
20	Pulley wheel	1	9501020	9501020	9501020	從動皮帶輪
21	Square key, 8x7x45L	3				雙圓平行鍵
22	Spring-washer M12	1				彈簧墊圈
23	Screw , M12x30	1				六角承窩螺絲
24	Shaft-B	1	1440200609	1440200609	1440200609	B軸
25	Gear- d (39T)	1	1360200907	1360200907	1360200907	齒輪
26	Gear- b (32T)	1	1360201002	1360201002	1360201002	齒輪
27	Gear- f (48T)	1	1360201100	1360201100	1360201100	齒輪
28	Gear- k (46T)	1	1360201208	1360201208	1360201208	齒輪
29	Gear- o (22T)	1	1360201306	1360201306	1360201306	齒輪
30	Plug-cover	2	9501030	9501030	9501030	護蓋
31	O-ring, P55x3.5	2				O型環
32	Fixed pin	2	1120206707	1120206707	1120206707	護蓋固定銷
33	Set screw	2				固定螺絲
34	Shaft-A	1	1440200707	1440200707	1440200707	A軸
34-1	Shaft-L	1	1440200805	1440200805	1440200805	L軸
35	Ball-bearing, 6305	1	91301029	91301029	91301029	滾珠軸承
36	Gear- l (25T)	1	1360201404	1360201404	1360201404	齒輪
36-1	Square key, 7x10x18L	2				雙圓平行鍵
37	Gear- m	1	1360206703	1360206703	1360206703	齒輪
38	Snap ring, S75	2				扣環
39	Snap ring, S30	3				扣環
40	Ball-bearing, 6006	2	91301013	91301013	91301013	滾珠軸承
41	Gear- e	1	1360201502	1360201502	1360201502	齒輪
42	Gear- a	1	1440202407	1440202407	1440202407	齒輪
43	Gear- c	1	1440202505	1440202505	1440202505	齒輪
44	Square key, 8x7x30L	1				雙圓平行鍵
45	Snap ring, S55	2				扣環
46	Snap ring, S38	2				扣環
47	Gear- h (30T)	1	1360201600	1360201600	1360201600	齒輪
48	Gear- j (51T)	1	1360207504	1360207504	1360207504	齒輪



## HEADSTOCK ASSMBLY (Spindle Bore : 115mm or 4")

ITEM NO.	Part Name	Amt. Used	Type: 22 Part No.	Type: 26 Part No.	Type: 30 Part No.	名稱
49	Square key, 8x7x25L	1				雙圓平行鍵
50	Spacer	1	1360206801	1360206801	1360206801	間隔圈
51	Cover	1	1360203104	1360203104	1360203104	護蓋
52	Spindle (A1-11)	1	4001052-A04	4001052-A04	4001052-A04	主軸
	(D1-11)	1	4001052-D04	4001052-D04	4001052-D04	
53	Taper roller bearing, 32032	1	91302018	91302018	91302018	滾珠軸承
54	Cover	1	9501054	9501054	9501054	主軸前護蓋
55	Hexagon socket screw, M6xP1.0x20L	6				六角承窩螺絲
56	Gear- p (95T)	1	M501056	M501056	M501056	齒輪
57	Gear- n (72T)	1	M501057	M501057	M501057	變速齒輪
58	Square key, 10x8x85L	1				雙圓平行鍵
59	Lock-nut	1	9501059	9501059	9501059	逼緊螺帽
60	M8xP1.25x8L	5	91120808	91120808		固定螺絲
61	Taper roller bearing, 32030	1	91302017	91302017	91302017	滾錐軸承
62	Lock-nut	1	9201062	9501062	9501062	逼緊螺帽
63	Gear (65T)	1	M501063	M501063	M501063	齒輪
64	Collar	1	9501064	9501064	9501064	軸環
65	Ball-bearing, 6028	1	91301049	91301049	91301049	滾珠軸承
66	Oil return collar	1	9501066	9501066	9501066	回油軸環
67	Cover	1	9501067	9501067	9501067	主軸後護蓋
68-1	Lock-nut	1	9501068	9501068	9501068	逼緊螺帽
68-2	Balance piece	3	9501068-1	9501068-1	9501068-1	平衡片
68-3	Set screw	6				定位螺絲
69	Idle gear shaft	1	9501069	9501069	9501069	惰輪軸
70	Spacer	4	1120206609	1120206609	1120206609	間隔圈
71	Idle gear (34T)	1	M501071	M501071	M501071	惰輪
72	O-ring, P29	1				O型環
73	Washer	1	112020761	112020761	112020761	墊圈
74	Hexagon socket screw, M6xP1.0x16L	16				六角承窩螺絲
75	Shaft-c	1	M501075	M501075	M501075	齒輪軸
76	Ball-bearing, 6304	2	91301028	91301028	91301028	滾珠軸承
77-1	Spacer	1	1360206909	1360206909	1360206909	間隔圈
77-2	Spacer	1	1360207004	1360207004	1360207004	間隔圈
78	Gear (42T)	1	M501078	M501078	M501078	齒輪
79	Gear (28T)	1	M501079	M501079	M501079	齒輪
80	Gear (65T)	1	M501080	M501080	M501080	齒輪
81	Square key, 8x7x65L	2				雙圓平行鍵
82	Cover	1	1360203908	1360203908	1360203908	護蓋
83	Shaft-D	1	1440200903	1440200903	1440200903	D軸
84	Gear (42T)	1	M501084	M501084	M501084	齒輪
85	Gear (56T)	1	M501085	M501085	M501085	齒輪
86	Square key, 8x7x20L	1				雙圓平行鍵
87	Snap ring, S45	1				扣環
88	Housing	1	1360204003	1360204003	1360204003	軸承蓋
89	Seal-oil, TC25x47x8L	1				油封
90	Square key, 6x6x12L	1				雙圓平行鍵
91	Collar	1	1121602203	1121602203	1121602203	軸環

## HEADSTOCK ASSMBLY (Spindle Bore : 115mm or 4")

ITEM NO.	Part Name	Amt. Used	Type: 22 Part No.	Type: 26 Part No.	Type: 30 Part No.	名稱
92	Taper pin, O # x25L	1				推拔銷
93	Gear (in)	1	1121600405	1121600405	9501093-2	輸出齒輪
	Gear (mm)	1	1121600307	1121600307	9401093-2	輸出齒輪
94	Washer	1				墊圈
95	Shifting shaft	3	9501095	9501095	9501095	撥桿軸
96	O-ring, P16	6				O型環
97	Plug	3	1120207704	1120207704	1120207704	塞子
98	Set screw	3	1360204209	1360204209	1360204209	定位螺絲
99	Shifting lever	3	9501099	9501099	9501099	搖臂
100	Shifting fork	1	112020781	112020781	112020781	撥塊
		1	112020791	112020791	112020791	撥塊
101	Shifting fork	1	1360204405	1360204405	1360204405	撥塊
102	Shifting lever	3	1360204503	1360204503	1360204503	搖臂
103	Shifting lever	3	1360204601	1360204601	1360204601	搖臂
104	Shaft	3	9501104	9501104	9501104	撥桿軸
105	Spring, D6xd0.8x25L	2				彈簧
106	Ball steel , $\phi$ 1/4"	2				鋼珠
107	Detent plate	1	9501107	9501107	9501107	定位片
108	Detent plate	1	9501108	9501108	9501108	定位片
109	Detent plate	1	9501109	9501109	9501109	定位片
110	Hub	2	9501110	9501110	9501110	變速把手
110-1	Hub	1	1360205304	1360205304	1360205304	變速把手
111	Square key, 5x5x15L	3				雙圓平行鍵
112	Ball steel , $\phi$ 5/16"	3				鋼珠
113	Spring, D8xd0.8x25L	1				彈簧
	Spring, D8xd1.1x29L	2				
114	Lever	3	1120207302	1120207302	1120207302	撥桿軸套
115	Knob	3	1120207400	1120207400	1120207400	電木把手
116	Shaft	1	9501116	9501116	9501116	撥桿軸
117	Shifting lever	2	9501117	9501117	9501117	搖臂
119	Shifting fork	2	133020011	133020011	133020011	撥塊
120	Detent plate	1	9501120	9501120	9501120	定位片
121	Detent plate	1	9501121	9501121	9501121	定位片
122	Knob	1	1360205804	1360205804	1360205804	變速把手
122-1	Knob	1	1360205902	1360205902	1360205902	變速把手
123	Shaft	1	9501123	9501123	9501123	撥桿軸
124	Washer	5	1120206109	1120206109	1120206109	墊圈
125	Lever	2	1120207204	1120207204	1120207204	後列變換齒輪把手
126	Pin	2	1361600107	1361600107	1361600107	調整銷
127	Set screw, M8xP1.25x8L	3				固定螺絲
128	O-ring , P18	5				O型環
129	Screw , M6xP1.0x14L	10				六角孔埋頭螺絲
130	Lenz-oil , $\phi$ 29	1	92552001	92552001	92552001	油鏡
131	Spring pin , $\phi$ 5x30L	9				彈簧銷
132	Snap ring, S12	3				扣環
133	Snap ring, S10	2				扣環
134	Set screw, M12xP1.75x20L	2				固定螺絲
135	Hexagon socket screw, M8xP1.25x35L	2				六角承窩螺絲

# 9-2 GEAR BOX

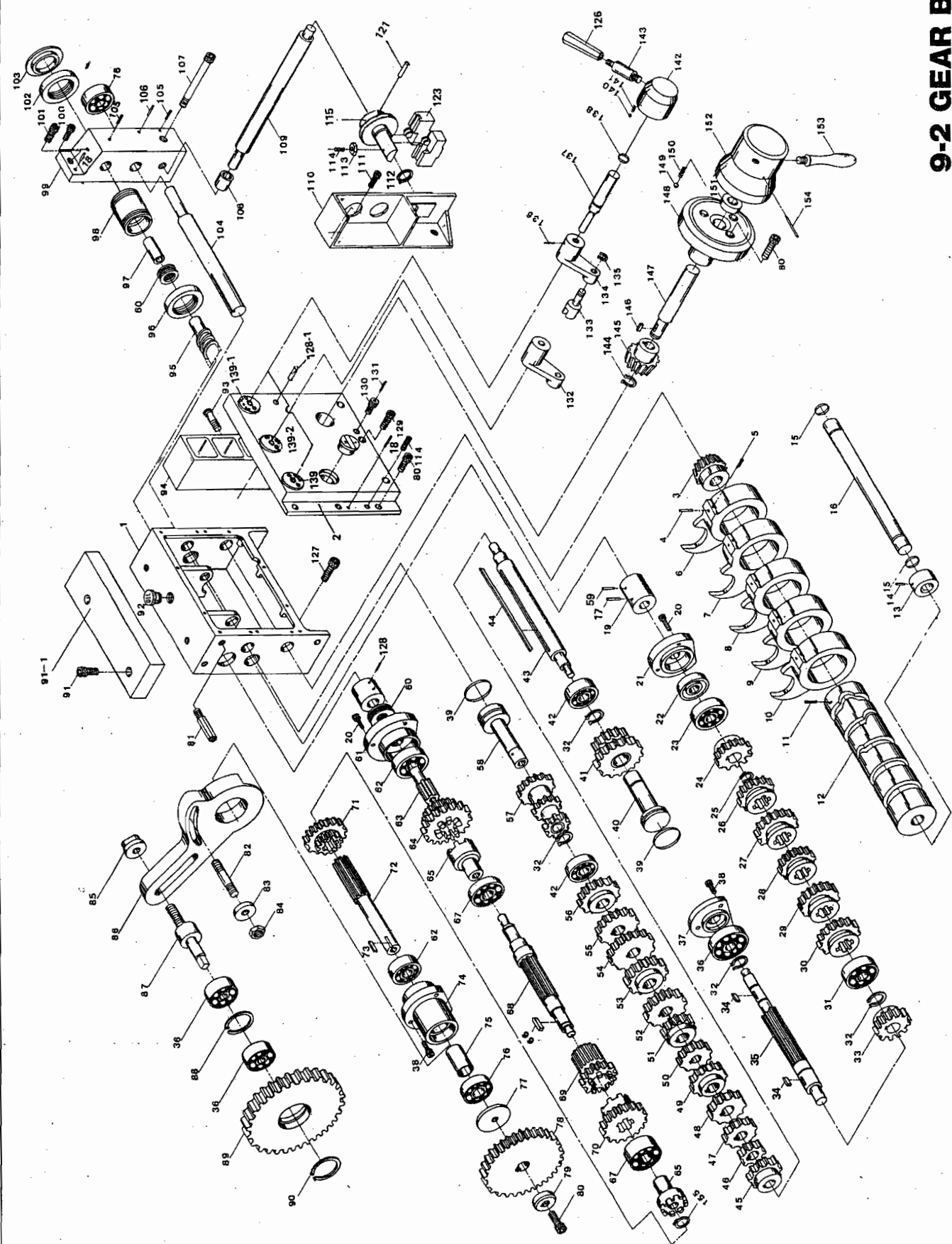

## GEAR BOX ASSEMBLY

ITEM NO.	Part Name	Amt. Used	Type: 20 GW Part No.	Type: 22, 26 Part No.	Type: 2280, 2680 Part No.	Type: 30 Part No.	名稱
1	Gear box	1	1210300307	1210300307	1210300307	1210300307	齒輪箱本體
2	Cover-gear box	1	142030011	142030011	142030011	142030011	齒輪箱蓋
3	Gear-driven bevel	1	121030041	121030041	121030041	121030041	從動傘齒輪
4	Pin-fixed	5	1210300503	1210300503	1210300503	1210300503	固定銷
5	Pin-split	5					開口銷
6	Claw-shifter	1	1210300601	1210300601	1210300601	1210300601	撥爪
7	Claw-shifter	1	1210300709	1210300709	1210300709	1210300709	撥爪
8	Claw-shifter	1	1210300807	1210300807	1210300807	1210300807	撥爪
9	Claw-shifter	1	1210300905	1210300905	1210300905	1210300905	撥爪
10	Claw-shifter	1	1210301000	1210301000	1210301000	1210301000	撥爪
11	Set screw, M8xP1.25x8L	1					固定螺絲
12	Cam-shifter	1	121030121	121030121	121030121	121030121	變速凸輪
13	Collar	1	1210301304	1210301304	1210301304	1210301304	H軸固定環
14	Set-screw , M8x12	1					車削螺絲
15	Ring-"O" , P18	2					O型環
16	Shaft-"A"	1	1210301402	1210301402	1210301402	1210301402	H軸
17	Pintaper , # 4x38	2					推拔銷
18	Pintaper , # 6x38	2	1210702301	1210702301	1210702301	1210702301	推拔銷
19	Collar-linkage	2	1210301500	1210301500	1210301500	1210301500	螺桿連接軸
20	Hexagon socket screw, M6xP1.0x20L	6					六角承窩螺絲
21	Cap-right	1	1210301608	1210301608	1210301608	1210301608	右下護蓋
22	Seal-oil , 20x40x10L	1					油封
23	Bearing-ball , 6204	1	91301018	91301018	91301018	91301018	滾珠軸承
24	Gear-"B" shaft (36T)	1	1210301706	1210301706	1210301706	1210301706	G軸齒輪
25	Snap ring , S25	2					扣環
26	Gear-"B" shaft (22T)	1	1210301804	1210301804	1210301804	1210301804	G軸齒輪
27	Gear-"B" shaft (22T)	1	1210301902	1210301902	1210301902	1210301902	G軸齒輪
28	Gear-"B" shaft (33T)	1	1210302007	1210302007	1210302007	1210302007	G軸齒輪
29	Gear-"B" shaft (22T)	1	1210302105	1210302105	1210302105	1210302105	G軸齒輪
30	Gear-"B" shaft (22T)	1	1210302203	1210302203	1210302203	1210302203	G軸齒輪
31	Bearing ball, 6004	1	91301006	91301006	91301006	91301006	滾珠軸承
32	Snap ring , S20	2					扣環
	Snap ring , S18	2					扣環
33	Gear-"B" shaft (22T)	1	1210302301	1210302301	1210302301	1210302301	G軸齒輪
34	Key-square , 6x6x20L	2					雙圓平行鍵
35	Shaft-"B"	1	1210302409	1210302409	1210302409	1210302409	G軸
36	Bearing ball , 6003	3	91301005	91301005	91301005	91301005	滾珠軸承
37	Cap-left	1	121030251	121030251	121030251	121030251	左下護蓋
38	Hexagon socket screw, M6xP1.0x20L	6					六角承窩螺絲
39	Ring-"O" , P36	2					O型環
40	Shaft-"C"	1	1210302605	1210302605	1210302605	1210302605	E軸
41	Gear-"C" shaft (20T.20T)	1	1210302703	1210302703	1210302703	1210302703	E軸齒輪
42	Bearing , 6203	2	91301016	91301016	91301016	91301016	滾珠軸承
43	Shaft-"D"	1	1210302801	1210302801	1210302801	1210302801	D軸
44	Key-square , 6x6x146L	1					雙圓平行鍵

## GEAR BOX ASSEMBLY

ITEM NO.	Part Name	Amt. Used	Type: 20 GW Part No.	Type: 22, 26 Part No.	Type: 2280, 2680 Part No.	Type: 30 Part No.	名稱
45	Gear-"D" shaft (19T)	1	1210302909	1210302909	1210302909	1210302909	D軸齒輪
46	Gear-"D" shaft (18T)	1	1210303004	1210303004	1210303004	1210303004	D軸齒輪
47	Gear-"D" shaft (20T)	1	1210303102	1210303102	1210303102	1210303102	D軸齒輪
48	Gear-"D" shaft (22T)	1	1210303200	1210303200	1210303200	1210303200	D軸齒輪
49	Gear-"D" shaft (23T)	1	1210303308	1210303308	1210303308	1210303308	D軸齒輪
50	Gear-"D" shaft (24T)	1	1210303406	1210303406	1210303406	1210303406	D軸齒輪
51	Gear-"D" shaft (27T)	1	1210303504	1210303504	1210303504	1210303504	D軸齒輪
52	Gear-"D" shaft (24T)	1	1210303602	1210303602	1210303602	1210303602	D軸齒輪
53	Gear-"D" shaft (26T)	1	1210303700	1210303700	1210303700	1210303700	D軸齒輪
54	Gear-"D" shaft (36T)	1	1210303808	1210303808	1210303808	1210303808	D軸齒輪
55	Gear-"D" shaft (27T)	1	1210303906	1210303906	1210303906	1210303906	D軸齒輪
56	Gear-"D" shaft (28T)	1	1210304001	1210304001	1210304001	1210304001	D軸齒輪
57	Gear-"E" shaft (18T.36T)	1	1210304109	1210304109	1210304109	1210304109	F軸齒輪
58	Shaft-"E"	1	1210304207	1210304207	1210304207	1210304207	F軸
59	Pin-taper , 3x35	1	1003502904	1003502904	1003502904	1003502904	鐵斜銷
60	Bearing-thrust, 51104	1	91303003	91303003	91303003	91303003	止推軸承
61	Cap	1	1210304305	1210304305	1210304305	1210304305	右上護套
62	Bearing ball , 6004V	2	91301008	91301008	91301008	91301008	滾珠軸承
63	Shaft-"F"	1	1210304403	1210304403	1210304403	1210304403	C軸
64	Gear-"F" shaft (35T.35T)	1	1210304501	1210304501	1210304501	1210304501	C軸齒輪
65	Shaft-"F"	1	1210304609	1210304609	1210304609	1210304609	離合器
		1	1210304707	1210304707	1210304707	1210304707	離合器
66	Square key, 4x4x20L	2					雙圓平行鍵
67	Bearing ball , 6005	2	91301010	91301010	91301010	91301010	滾珠軸承
68	Shaft-"G"	1	1210304805	1210304805	1210304805	1210304805	A軸
69	Gear-"G" shaft	1	1210304903	1210304903	1210304903	1210304903	A軸變速齒輪
70	Gear-"G" shaft (36T)	1	1210305008	1210305008	1210305008	1210305008	A軸齒輪
71	Gear-"H" shaft (38T.19T)	1	1210305106	1210305106	1210305106	1210305106	B軸離合齒輪
72	Shaft-"H"	1	1420300206	1420300206	1420300206	1420300206	B軸
73	Key-square , 6x6x13L	1					單圓平行鍵
74	Cap-bearing	1	1210305204	1210305204	1210305204	1210305204	軸承套
75	Bushing-"H" shaft	1	1210305302	1210305302	1210305302	1210305302	間隔環
76	Bearing ball , 6004Z	2	91301007	91301007	91301007	91301007	滾珠軸承
77	Spacer	1	1361600303	1361600303	1361600303	1361600303	B軸擋塊
78	Gear-drive shaft (in 57T)	1	1121600601	1121600601	1121600601	1121600601	傳動齒輪
	(mm 92T)	1	1121600503	1121600503			
79	Washer , M8	1	1121602105	1121602105	1121602105	1121602105	特殊墊塊
80	Hexagon socket screw, P1.25x16L	1					六角承窩螺絲
81	Bolt-lock end cover	1	1362100204	1362100204	1362100204	1362100204	側蓋鎖緊螺栓
82	Stud	1	1361600509	1361600509	1361600509	1361600509	螺栓
83	Washer , 5/8"	1	1362101407	1362101407	1362101407	1362101407	墊圈
84	Nut , M16	1					螺帽
85	Nut-lock stud	1	1121601706	1121601706	1121601706	1121601706	齒輪軸螺帽
86	Quadrat	1	136160042	136160042	136160042	4002086	可調支架
87	Stud-gear	1	1361600607	1361600607	1361600607	1361600607	活動齒輪軸

## GEAR BOX ASSEMBLY

ITEM NO.	Part Name	Amt. Used	Type: 20 GW Part No.	Type: 22, 26 Part No.	Type:2280, 2680 Part No.	Type: 30 Part No.	名稱
88	Snap-ring , R40	1					扣環
89	Gear-quadrat (in 71T)	1	1121600209				惰輪
	(in 82T)	1		1321600203			
	(in 85T)	1			1531600200	1531600200	
	(mm 84T)	1	1121600101				
	(mm 98T)	1		1321600105			
	(mm 122T)	1			1531600102	1531600102	
90	Snap ring , S18	1					扣環
91	Hexagon socket screw, M6xP1.0x25L	2					六角承窩螺絲
91-1	Cover	1	1362101103	1362101103	1542100104	1542100104	齒輪箱上蓋
92	Plug-oil inlet	1	1122101401	1122101401	1122101401	1122101401	油塞
93	Hexagon socket screw, M6xP1.0x65L	2					六角承窩螺絲
94	Seat-pilot light	1	1210701206	1210701206	1210701206	1210701206	指示燈座
95	Lead-screw (6 feet in)	1	1420700206	1420700206			導螺桿
	(6 feet mm)	1	1420700108	1420700108			
	(8 feet in)	1	1430700209	1430700209			
	(8 feet mm)	1	1430700101	1430700101			
	(10 feet in)	1			1440700202	1440700202	
	(10 feet mm)	1			1440700104	1440700104	
	(15 feet in)	1			4002095-E15	4002095-E15	
	(15 feet mm)	1			4002095-M15	4002095-M15	
	(18 feet in)	1			4002095-E18	4002095-E18	
	(18 feet mm)	1			4002095-M18	4002095-M18	
96	Nut-lock	1	1420700706	1420700706	1420700706	1420700706	導螺桿調整軸套
97	Bushing-leadscrew	1					
98	Plug-lead screw	1	1420700706	1420700706	1420700706	1420700706	導螺桿調整軸套
99	Supporter-for Lead-screw, feed rod	1	142070081	142070081	142070081	142070081	三桿支架
100	Plug-oil inlet	1	1122101509	1122101509	1122101509	1122101509	銅油塞
101	Hexagon socket screw, M8xP1.25x30L	1					六角承窩螺絲
102	Nut-lock	1	1420700706	1420700706	1420700706	1420700706	導螺桿調整軸套
103	Plug-plastic	1	1122101607	1122101607	1122101607	1122101607	側封蓋
104	Rod-feed (6 feet)	1	1420700402	1420700402			自動進刀輸出軸
	(8 feet)	1	1420700304	1420700304			
	(10 feet)	1			1440700300	1440700300	
	(12 feet)	1			4002104-012	4002104-012	
	(15 feet)	1			4002104-015	4002104-015	
	(18 feet)	1			4002104-018	4002104-018	
105	Hexagon socket screw, M6xP1.0x20L	2					六角承窩螺絲
106	Pin-taper , 6x100L	1					推拔銷
107	Hexagon socket screw	1					六角承窩螺絲
108	Bushing-spindle starting rod	1	1420700902	1420700902	1420700902	1420700902	啟動桿軸襯
109	Rod-spindle starting switch (6 feet)	1	1420701105	1420701105	1420701105	1420701105	啟動桿

## GEAR BOX ASSEMBLY

ITEM NO.	Part Name	Amt. Used	Type: 20 GW Part No.	Type: 22, 26 Part No.	Type:2280, 2680 Part No.	Type: 30 Part No.	名稱
	(8 feet)	1	1430700405	1430700405	1430700405		
	(10 feet)	1		1440700408	1440700408	1440700408	
	(12 feet)	1		4002109-012	4002109-012	4002109-012	
	(15 feet)	1		4002109-015	4002109-015	4002109-015	
	(18 feet)	1		4002109-018	4002109-018	4002109-018	
110	Seat-switch	1	1210701304	1210701304	1210701304	1210701304	開關護板
111	Hexagon socket screw, M8xP1.25x25L	2					六角承窩螺絲
112	Snap ring , S30	1					扣環
113	Nut , M6xP1.0	1					螺帽
114	Set screw, M6xP1.0x20L	1	1210305400	1210305400	1210305400	1210305400	固定螺絲
115	Bracket	1	1210701402	1210701402	1210701402	1210701402	啟動器
121	Pin , 5x25L	1					彈簧銷
122	Hexagon socket screw, M6xP1.0x8L	1					六角承窩螺絲
123	Switch	2					微動開關
126	Knob	3	1120207400	1120207400	1120207400	1120207400	電木把手
127	Screw Socket head cap, M10xP1.5x35L	4					螺栓
128	Pin-taper , 0x35	1	1003502904	1003502904	1003502904	1003502904	鋁斜銷
128-1	Pin-taper , 6x45	1					推拔銷
129	Hexagon socket screw, M8xP1.25x40L	7					六角承窩螺絲
130	Screw-taper, oil outlet, PT 3/8	1					油塞
132	Shifter	1	1210305606	1210305606	1210305606	1210305606	變速撥塊
133	Shoe-shifter	2	1210305704	1210305704	1210305704	1210305704	撥塊
		1	1210305802	1210305802	1210305802	1210305802	撥塊
134	Shifter	1	1210306005	1210306005	1210306005	1210306005	變速撥塊
		1	1210305900	1210305900	1210305900	1210305900	
135	Snap ring , S10	3					扣環
136	Pin-spring , 5x25	3					彈簧銷
137	Shaft-shifter	3	1210306103	1210306103	1210306103	1210306103	變速撥桿軸
138	Ring-"O" , P12	3					O型環
139	Detent plate	1	1210306201	1210306201	1210306201	1210306201	變速定位片
139-1	Detent plate	1	1210306309	1210306309	1210306309	1210306309	變速定位片
139-2	Detent plate	1	1210306407	1210306407	1210306407	1210306407	變速定位片
140	Ball steel , 1/4	3	91820104	91820104	91820104	91820104	鋼珠
141	Spring , 1x6x30L	3					彈簧
142	Hub	3	1210306505	1210306505	1210306505	1210306505	把手頭
143	Lever	3	1210306701	1210306701	1210306701	1210306701	撥桿軸套
144	Snap ring, S15	1					扣環
145	Gear-drive bevel	1	1210306809	1210306809	1210306809	1210306809	主動傘齒輪
146	Key-square , 5x5x25L	1					雙圓平行鍵
147	Shaft-bevel gear	1	1210306907	1210306907	1210306907	1210306907	十段變速軸

## GEAR BOX ASSEMBLY

ITEM NO.	Part Name	Amt. Used	Type: 20 GW Part No.	Type: 22, 26 Part No.	Type: 2280, 2680 Part No.	Type: 30 Part No.	名稱
148	Seat-gear shifting	1	1210307002	1210307002	1210307002	1210307002	十段變速座
149	Ball steel , 5/16	2					鋼珠
150	Spring , 1x6x22L	2					彈簧
151	Seal-oil , 25x35x10L	1					油封
152	Hub	1	1210307100	1210307100	1210307100	1210307100	十段變速把手頭
153	Handle	3	1120207204	1120207204	1120207204	1120207204	把手
		3	1220200100	1220200100	1220200100	1220200100	電木把手
154	Pin, 5x50	1					彈簧銷



# 9-3 APRON

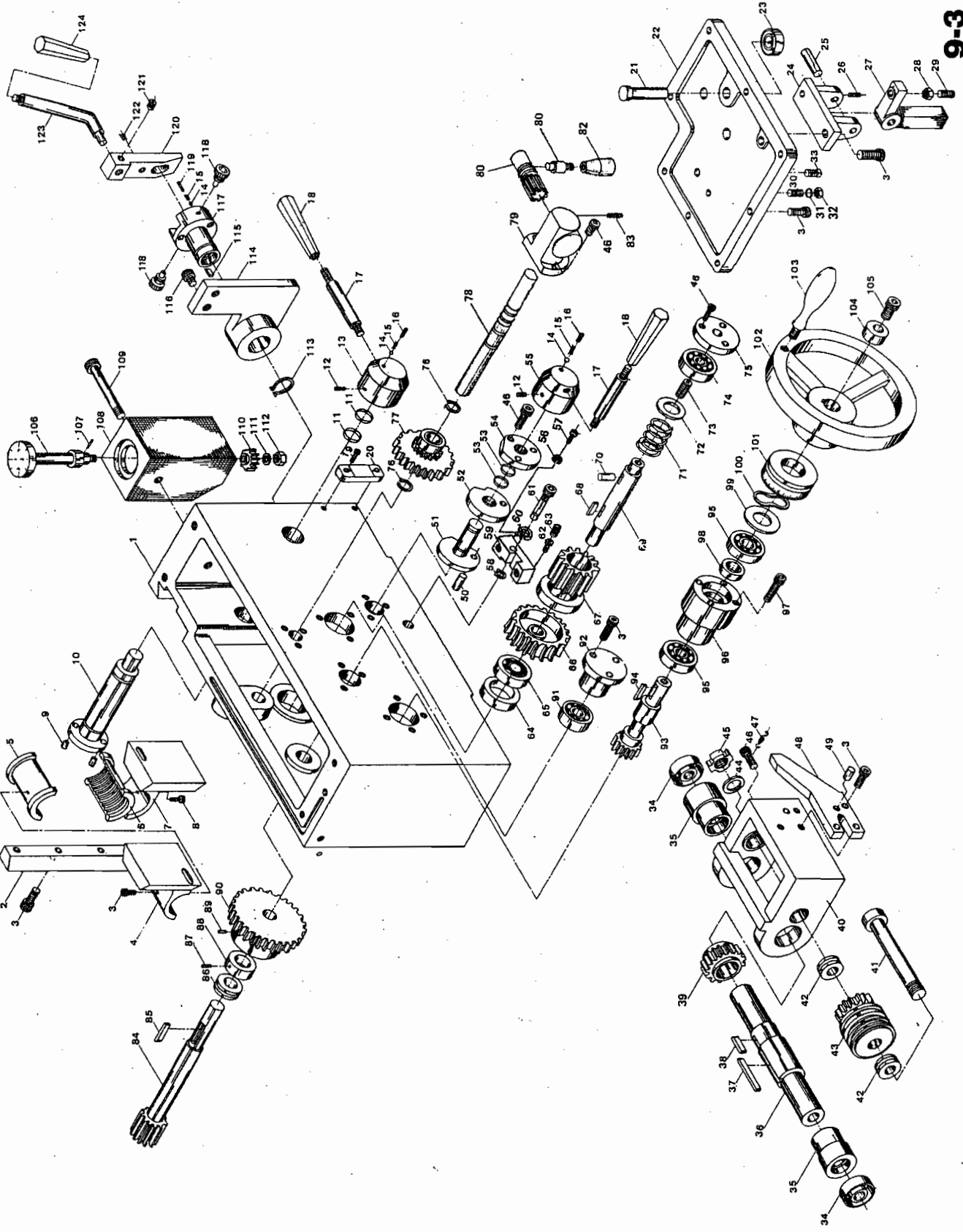

## APRON ASSEMBLY

ITEM NO.	Part Name	Amt. Used	Type: 20 GW Part No.	Type: 22, 26 Part No.	Type:2280, 2680 Part No.	Type: 30 Part No.	名稱
1	Body-Apron (right hand)	1	142090174	142090174	142090174	142090174	護床本體
	(left hand)	1	142090013	142090013	142090013	142090013	
2	Gib	1	1420900804	1420900804	1420900804	1420900804	炭條
3	Hexagon socket screw, M6xP1.0x20L	17					六角承窩螺絲
4	Holder-half nut (right)	1	1420900402	1420900402	1420900402	1420900402	半開螺帽座
	(left)	1	1420900304	1420900304	1420900304	1420900304	
5	Nut-half (in)	1	142090053	142090053	142090053	142090053	半開螺帽
	(mm)	1	142090063	142090063	142090063	142090063	
6	Nut-half (in)	1	142090053	142090053	142090053	142090053	半開螺帽
	(mm)	1	142090063	142090063	142090063	142090063	
7	Holder-half nut	1					
8	Hexagon socket screw, M6xP1.0x16L	1					六角承窩螺絲
9	Pin-sliding	2	1210902507	1210902507	1210902507	1210902507	滑塊銷
10	Shaft-half nut (right)	1	1210900807	1210900807	1210900807	1210900807	半開螺帽心軸
	(left)	1	1210900709	1210900709	1210900709	1210900709	
11	Ring-O , P26	2					O型環
12	Set screw, M12xP1.75x20L	2					固定螺絲
13	Hub (right)	1	121090141	121090141	121090141	121090141	撥桿軸套
	(left)	1	1210901304	1210901304	1210901304	1210901304	
14	Ball-steel , 1/4"	4	91820104	91820104	91820104	91820104	鋼珠
15	Spring , φ 1x6x30L	3					彈簧
16	Set screw, M8xP1.25x10L	2					固定螺絲
17	Lever	2	1210902703	1210902703	1210902703	1210902703	手柄
18	Knob	2	1120207400	1120207400	1120207400	1120207400	電木把手
19	Hexagon socket screw, M10xP1.5x25L	2					六角承窩螺絲
20	Lenx-oil, CTA-8	1	1210902801	1210902801	1210902801	1210902801	油鏡
21	Shaft-auto stop	1	1210902909	1210902910	1210902911	1210902912	挺桿
22	Cover-bottom apron	1	1210903004	1210903004	1210903004	1210903004	護床底蓋
23	Seal-oil , 15x25x7	1					油封
24	Seat-tappet	1	1121601804	1121601804	1121601804	1121601804	自動停止挺桿座
25	Shaft-tappet	1	1121601902	1121601902	1121601902	1121601902	止動心軸
26	Set screw, M6xP1.0x16L	2					固定螺絲
27	Tappet	1	1121602007	1121602007	1121602007	1121602007	自動停止挺桿座
28	Nut , M8xP1.25	1					螺帽
29	Set screw, M8xP1.25x30L	1					固定螺絲
30	Set screw, M6xP1.0x40L	1					固定螺絲
31	Ring-O , P6	1					O型環
32	Nut , M6xP1.0	1					螺帽
33	Screw-oil leakage , PT1/4	1					油塞
34	Seal-oil , 34x45x11L	2					油封

## APRON ASSEMBLY

ITEM NO.	Part Name	Amt. Used	Type: 20 GW Part No.	Type: 22, 26 Part No.	Type:2280, 2680 Part No.	Type: 30 Part No.	名稱
35	Bushing	2	1420900902	1420900902	1420900902	1420900902	軸襯
36	Sleeve-feed rod	1	1420901007	1420901007	1420901007	1420901007	自動進刀軸套
37	Key-square , 6x6x42L	1					雙圓平行鍵
38	Key-square , 6x6x12L	1					雙圓平行鍵
39	Gear	1	1210903200	1210903200	1210903200	1210903200	齒輪
40	Seat-worm	1	1210903308	1210903308	1210903308	1210903308	蝸桿座
41	Shaft-worm	1	1210903406	1210903406	1210903406	1210903406	蝸桿心軸
42	Bearing-thrust , 2904	2	91311005	91311005	91311005	91311005	止推軸承
43	Worm gear	1	1420901105	1420901105	1420901105	1420901105	蝸桿
44	Washer-lock , 20	1					太陽墊圈
45	Nut	1					蝸桿心軸螺帽
46	Hexagon socket screw, M6xP1.0x12L	8					六角承窩螺絲
47	Spring,φ 1x10x60L (right)	1	121090541	121090541	121090541	121090541	彈簧
	(left)	1	121090551	121090551	121090551	121090551	
48	Block-safe device (right)	1	1210901000	1210901000	1210901000	1210901000	安全塊
	(left)	1	1420900706	1420900706	1420900706	1420900706	
49	Pin , 5x18L	2					彈簧銷
50	Pin	1					
51	Shaft-auto feed (right)	1	1210901206	1210901206	1210901206	1210901206	撥軸
	(left)	1	1210901108	1210901108	1210901108	1210901108	
52	Collar	1					撥軸
53	Ring-O , P16	2					O型環
54	Cover	1	1210903602	1210903602	1210903602	1210903602	軸蓋
55	Hub (right)	1	121090141	121090141	121090141	121090141	撥桿軸套
	(left)	1	1210901304	1210901304	1210901304	1210901304	
56	Spring washer , M12	1					彈簧墊圈
57	Hexagon socket screw, M8xP1.25x12L	1					六角承窩螺絲
58	Snap ring , S10	1					扣環
59	Lever	1	1210903700	1210903700	1210903700	1210903700	自動停止槓桿
60	Spring washer , M12	1					彈簧墊圈
61	Screw	1	1210903808	1210903808	1210903808	1210903808	槓桿心軸
62	Hexagon socket screw, M5xP0.8x20L	1					六角承窩螺絲
63	Spring	1	1210905606	1210905606	1210905606	1210905606	彈簧
64	Spacer	1	1210903906	1210903906	1210903906	1210903906	密封塊
65	Bearing ball , 6005V	1	91301012	91301012	91301012	91301012	滾珠軸承
66	Worm-wheel	1	1420901203	1420901203	1420901203	1420901203	蝸輪
67	Wheel-friction	1	1420901301	1420901301	1420901301	1420901301	離合齒輪
68	Key-square , 7x7x12L	1					雙圓平行鍵
69	Shaft-worm wheel	1	1210904001	1210904001	1210904001	1210904001	離合器心軸
70	Pin	1	1210904109	1210904109	1210904109	1210904109	墊圈擋塊
71	Spring, compressing	1	1210905302	1210905302	1210905302	1210905302	彈簧
72	Washer	1	1210904207	1210904207	1210904207	1210904207	墊片
73	Screw-hexa. Socket headless set	1					固定螺絲
74	Bearing ball , 6204	1	91301018	91301018	91301018	91301018	滾珠軸承
75	Cover	1	1210904305	1210904305	1210904305	1210904305	離合器

## APRON ASSEMBLY

ITEM NO.	Part Name	Amt. Used	Type: 20 GW Part No.	Type: 22, 26 Part No.	Type: 2280, 2680 Part No.	Type: 30 Part No.	名稱
76	Snap ring , S20	2					扣環
77	Gear	1	1420901409	1420901409	1420901409	1420901409	齒輪
78	Shaft-cross feed	1	121090441	121090441	121090441	121090441	縱橫變換軸
79	Set (right)	1	1210901608	1210901608	1210901608	1210901608	變換軸套
80	(left)	1	1210901500	1210901500	1210901500	1210901500	
81	Shaft-lever	1	1210904501	1210904501	1210904501	1210904501	縱橫變換齒輪
82	Lever	1	1120207400	1120207400	1120207400	1120207400	電木把手
83	Screw-hexa. Socket headless set	1					固定螺絲
84	Pinion-rack	1	121094707	121094707	121094707	121094707	中間軸
85	Key-square , 6x6x20L	1					雙園平行鍵
86	Bering-middle , NK20/22	1	91311001	91311001	91311001	91311001	滾針軸承
87	Set screw, M6xP1.0x10L	1					固定螺絲
88	Collar	1	1210904805	1210904805	1210904805	1210904805	固定圈
89	Pin-spring , 6x36L	1					彈簧銷
90	Gear	1	1210904903	1210904903	1210904903	1210904903	中間軸齒輪
91	Bearing ball , 6003	1	91301005	91301005	91301005	91301005	滾珠軸承
92	Cover	1	1210905008	1210905008	1210905008	1210905008	軸套
93	Pinion-handwheel	1	1210905106	1210905106	1210905106	1210905106	手輪心軸
94	Key-square , 6x6x25L	1					雙園平行鍵
95	Bearing ball , 6004V	2	91301008	91301008	91301008	91301008	滾珠軸承
96	Seat	1	1210905204	1210905204	1210905204	1210905204	軸承套
97	Hexagon socket screw, M5xP0.8x20L	4					六角承窩螺絲
99	Waher	1	1210701608	1210701608	1210701608	1210701608	墊塊
100	Washer-wave type	1					浪型墊圈
101	Dial-rack (in)	1	1220900104	1220900104	1220900104	1220900104	刻度環
	(mm)	1	1220900202	1220900202	1220900202	1220900202	
102	Handwheel	1	112210171	112210171	112210171	112210171	手輪
103	Handle	1	1121102002	1121102002	1121102002	1121102002	手柄
104	Washer-lock	1	1122101901	1122101901	1122101901	1122101901	鎖緊墊片
105	Hexagon socket screw, M8xP1.25x20L	1					六角承窩螺絲
106	Dial-thread chasing (in)	1	1003514708	1003514708	1003514708	1003514708	指示表規
	(mm)	1	100351491	100351491	100351491	100351491	
107	Pin	1					
108	Seat-dial shaft	1	1003514502	1003514502	1003514502	1003514502	車牙表規座
109	Hexagon socket screw, M10xP1.25x65L	1					六角承窩螺絲
110	Gear (in 16T)	1	1003514600	1003514600	1003514600	1003514600	齒輪
	(mm 11T)	1	1003502502	1003502502	1003502502	1003502502	
	(mm 13T)	1	1003502600	1003502600	1003502600	1003502600	
	(mm 14T)	1	1003514806	1003514806	1003514806	1003514806	
	(mm 15T)	1	1003502708	1003502708	1003502708	1003502708	
111	Washer-spring , 10	1					彈簧墊圈
112	Nut , M10xP1.5	1					螺帽
113	Snap ring , S30	1					扣環

## APRON ASSEMBLY

ITEM NO.	Part Name	Amt. Used	Type: 20 GW Part No.	Type: 22, 26 Part No.	Type: 2280, 2680 Part No.	Type: 30 Part No.	名稱
114	Seat-switch	1	1210701706	1210701706	1210701706	1210701706	開關座
115	Key-square , 6x8x25L	1					雙園平行鍵
116	Hexagon socket screw, M8xP1.25x16L	2					六角承窩螺絲
117	Bracket	1	121070181	121070181	121070181	121070181	啟動桿座
118	Screw-lock	2					特殊固定螺栓
119	Screw-hexa. Socket headless cap	1	1210702007	1210702007	1210702007	1210702007	停止定位銷
120	Seat-lever	1	1210702105	1210702105	1210702105	1210702105	啟動桿
121	Set screw, M8xP1.25x8L	2					固定螺絲
122	Spring	1					彈簧
123	Lever	1	1210702203	1210702203	1210702203	1210702203	把手
124	Sleeve-lever	1	1122103601	1122103601	1122103601	1122103601	電木把手

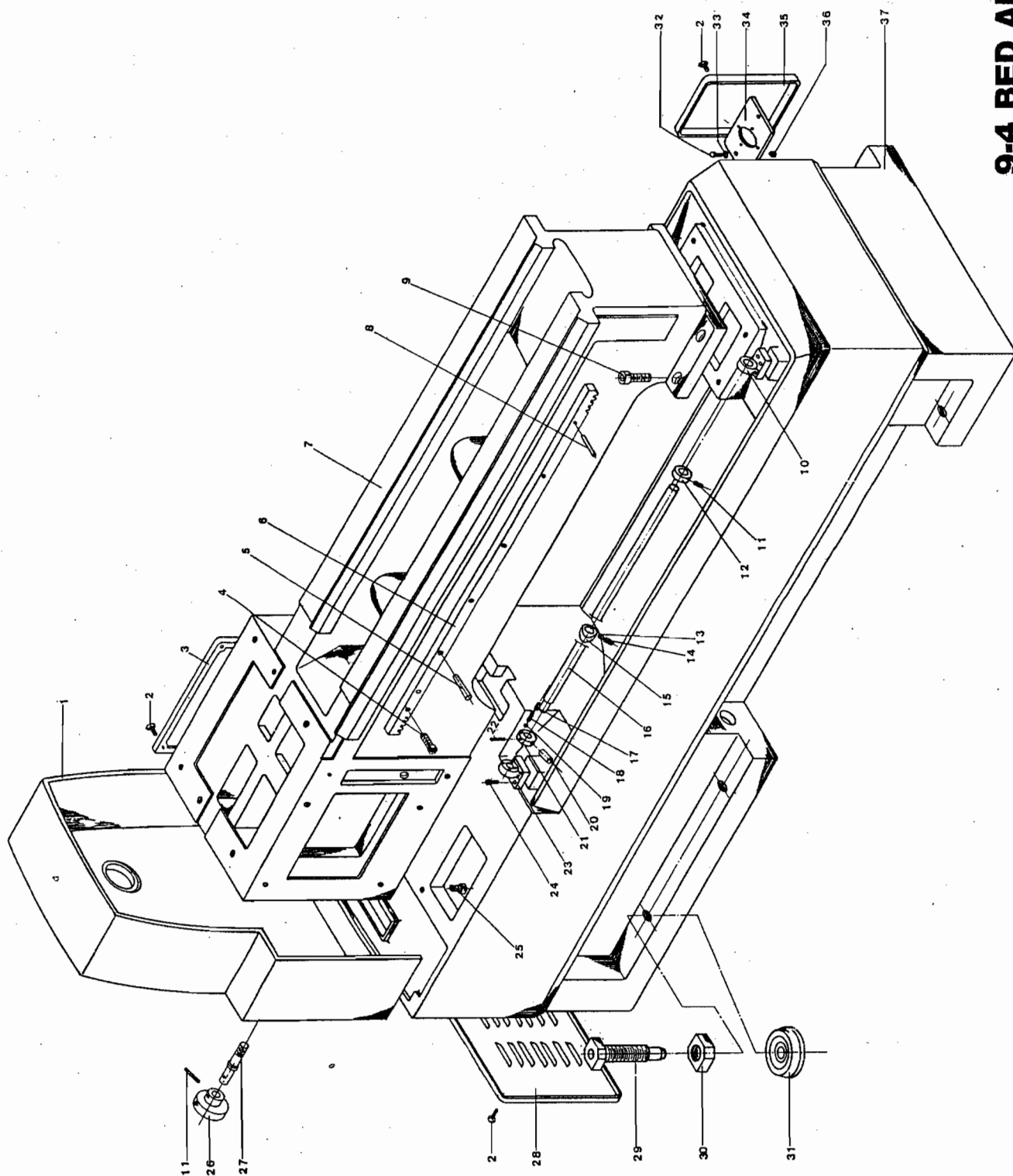

**9-4 BED AND BASE**

## BED AND BASE ASSEMBLY

ITEM NO.	Part Name	Amt. Used	Type: 20 GW Part No.	Type: 22 Part No.	Type: 26 Part No.	Type: 30 Part No.	名稱
1	Cover-end	1	1361600705	1431600100	1531600308	1541600301	主軸側蓋
	(10 feet Ø85mm)	1		1441600103	1541600301		
	(10 feet Ø115mm)	1		4004001-022	4004001-026	4004001-030	
2	Head, M6xP1.0x20L	12					十字埋頭螺絲
3	Cover-electric box	1	1122102006	1122102006	1122102006	1122102006	配電箱板蓋
4	Hexagon socket screw, M6xP1.0x25L	10					六角承窩螺絲
5	Pin-taper, 6x35 (6 feet)	2					彈簧銷
	(8 feet)	5					
	(10 feet)	5					
6	Rack (6 feet)	1	1420701007	1420701007	1420701007		齒條
	(8 feet)	1	143070051	143070051	143070051		
	(10 feet)	1		144070051	144070051	144070051	
7	Bed	1					床身
9	Hexagon socket screw, M16xP2.0x45L	4					六角承窩螺絲
10	Supporter-shaft	1	1122102104	1122102104	1122102104	1122102104	右軸台
11	Set screw, M6xP1.0x10L	2					固定螺絲
12	Collar	1	1122102202	1122102202	1122102202	1122102202	停止軸套環
13	Shoe-brass	4	1122102300	1122102300	1122102300	1122102300	停止凸輪墊塊
14	Set screw, M6xP1.0x6L	1					固定螺絲
15	Cam-auto feed stopping	4	1122102408	1122102408	1122102408	1122102408	自動進刀停止凸輪
16	Shaft-auto stopping (6 feet)	1	1222100308	1222100308	1222100308		停止軸
	(8 feet)	1	1432100109	1432100109	1432100109		
	(10 feet)	1		1242100108	1242100108	1242100108	
	(12 feet)	1		4004016-012	4004016-012	4004016-012	
	(15 feet)	1		4001016-015	4001016-015	4001016-015	
	(18 feet)	1		4004016-018	4004016-018	4004016-018	
17	Set screw, M8xP1.25x8L	1					固定螺絲
18	Spring, 1x6x10L	1					彈簧
19	Ball steel, 1/4"	1	91820104	91820104	91820104	91820104	鋼珠
20	Lever-turning shaft	4	1122103807	1122103807	1122103807	1122103807	停止轉輪把手
21	Collar	1	1122103905	1122103905	1122103905	1122103905	自動停止轉輪
22	Set screw, M8xP1.25x10L	1					固定螺絲
23	Supporter-shaft	1	1122102604	1122102604	1122102604	1122102604	左軸台
24	Hexagon socket screw, M8xP1.25x16L	4					六角承窩螺絲
25	Hexagon socket screw, M16xP2.0x55L	8					六角承窩螺絲
26	Plug	1	1122102702	1122102702	1122102702	1122102702	側蓋鎖緊螺栓塞
27	Bolt-lock	1					
28	Cover-motor seat	2	1362100900	1362100900	1362100900	1362100900	床頭馬達孔蓋板

## BED AND BASE ASSEMBLY

ITEM NO.	Part Name	Amt. Used	Type: 20 GW Part No.	Type: 22 Part No.	Type: 26 Part No.	Type: 30 Part No.	名稱
29	Bolt-set machine	6	1122102800	1122102800	1122102800	1122102800	固定螺栓
30	Nut-lock	6	1122102800	1122102800	1122102800	1122102800	固定螺栓螺帽
31	Block-leveling	6	1003501809	1003501809	1003501809	1003501809	墊塊
32	Bolt-hexa. head , M8x38	2					外六角頭螺絲
33	Washer , W5/8"	2					墊圈
34	Seat-coolant pump	1	121010051	121010051	121010051	121010051	冷卻泵浦座
35	Cover-coolant motor seat (有插座孔)	1	1005000403	1005000403	1005000403	1005000403	泵浦外蓋
	(無插座孔)	1	1005000501	1005000501	1005000501	1005000501	
36	Nut-lock , M8	2					螺帽
37	Base	1					底座



# 9-5 BRAKE SYSTEM

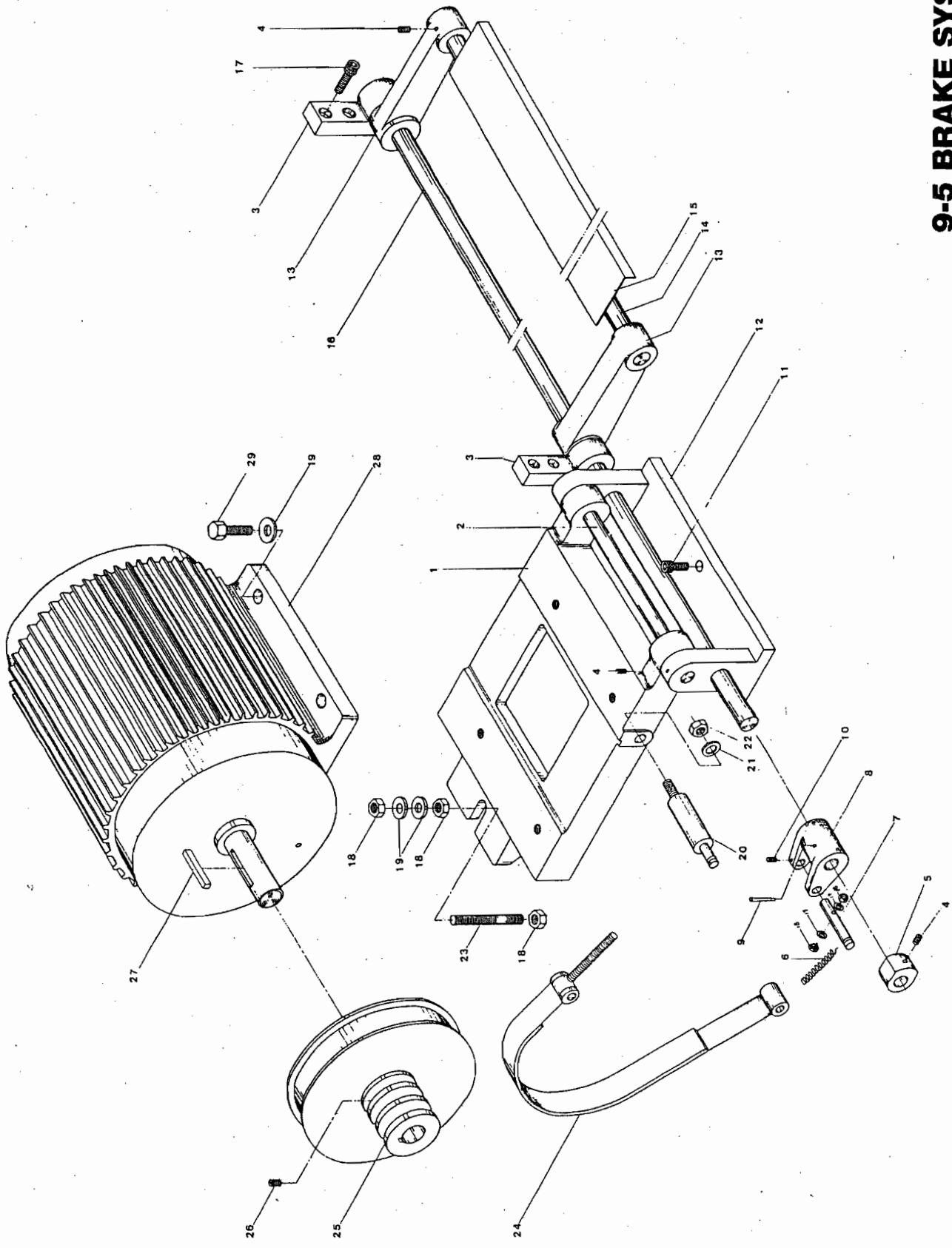

## BRAKE SYSTEM

ITEM NO.	Part Name	Amt. Used	Type: 20 GW Part No.	Type: 22 Part No.	Type: 26 Part No.	Type: 30 Part No.	名稱
1	Seat-motor	1	1420400103	1420400103	1420400103	1420400103	馬達底板
2	Shaft-motor seat	1	1420400201	1420400201	1420400201	1420400201	基座樞軸
3	Block	2	1420100500	1420100500	1420100500	1420100500	軸台
4	Set screw, M6xP1.0x12L	1					固定螺絲
5	Cam	1	1210400606	1210400607	1210400608	1210400609	凸輪
6	Spring	1	1420400309	1420400309	1420400309	1420400309	彈簧
7	Shaft-brake belt	1	1210400704	1210400704	1210400704	1210400704	煞車帶插銷
8	Arm-brake	1	1210400802	1210400802	1210400802	1210400802	制動搖臂
9	Pin-taper , 4x38L	1					推拔銷
10	Set screw, M6xP1.0x10L	1					固定螺絲
11	Hexagon socket screw, M10xP1.5x30L	3					六角承窩螺絲
12	Bracket-motor seat	1	1420100608	1420100608	1420100608	1420100608	馬達基座托架
13	Bracket-pedal	2	1210400900	1210400900	1210400900	1210400900	踏板支架
15	Pedal-brake (6 feet)	1	1220400109	1220400109	1220400109		踏板
	(8 feet)	1	1230400102	1230400102	1230400102		
	(10 feet)	1		1240400105	1240400105	1240400105	
16	Shaft-pedal bracket	1					制動踏板軸
	(6 feet)	1	1420100402	1420100402	1420100402		
	(8 feet)	1	1430100307	1430100307	1430100307		
	(10 feet)	1		1440100408	1440100408	1440100408	
17	Hexagon socket screw, M8xP1.25x25L	4					六角承窩螺絲
18	Nut , M16	6					螺帽
19	Washer , M16	4					平墊圈
20	Bolt-adjusting	1	1210401005	1210401005	1210401005	1210401005	調整螺栓固定銷
21	Washer , M12	1					平墊圈
22	Nut , M12	1					螺帽
23	Bolt-adjusting	1	1420400407	1420400407	1420400407	1420400407	調整螺栓
24	Belt-brake	1	1003519605	1003519605	1003519605	1003519605	煞車帶
25	Belt pulley	1					馬達皮帶輪
	(7.5HP/10HP/50HZ)	1	3005025-005	3005025-005	3005025-005		
	(7.5HP/10HP/60HZ)	1	3005025-004	3005025-004	3005025-004		
	(15HP/50HZ)	1		4005025-003	4005025-003	4005025-003	
	(15HP/60HZ)	1		4005025-002	4005025-002	4005025-002	
27	Key , 7x7x55L	1					雙圓平行鍵
28	Motor	1					馬達
29	Bolt-hexa. Head, M10x30L	4					六角鋼螺絲

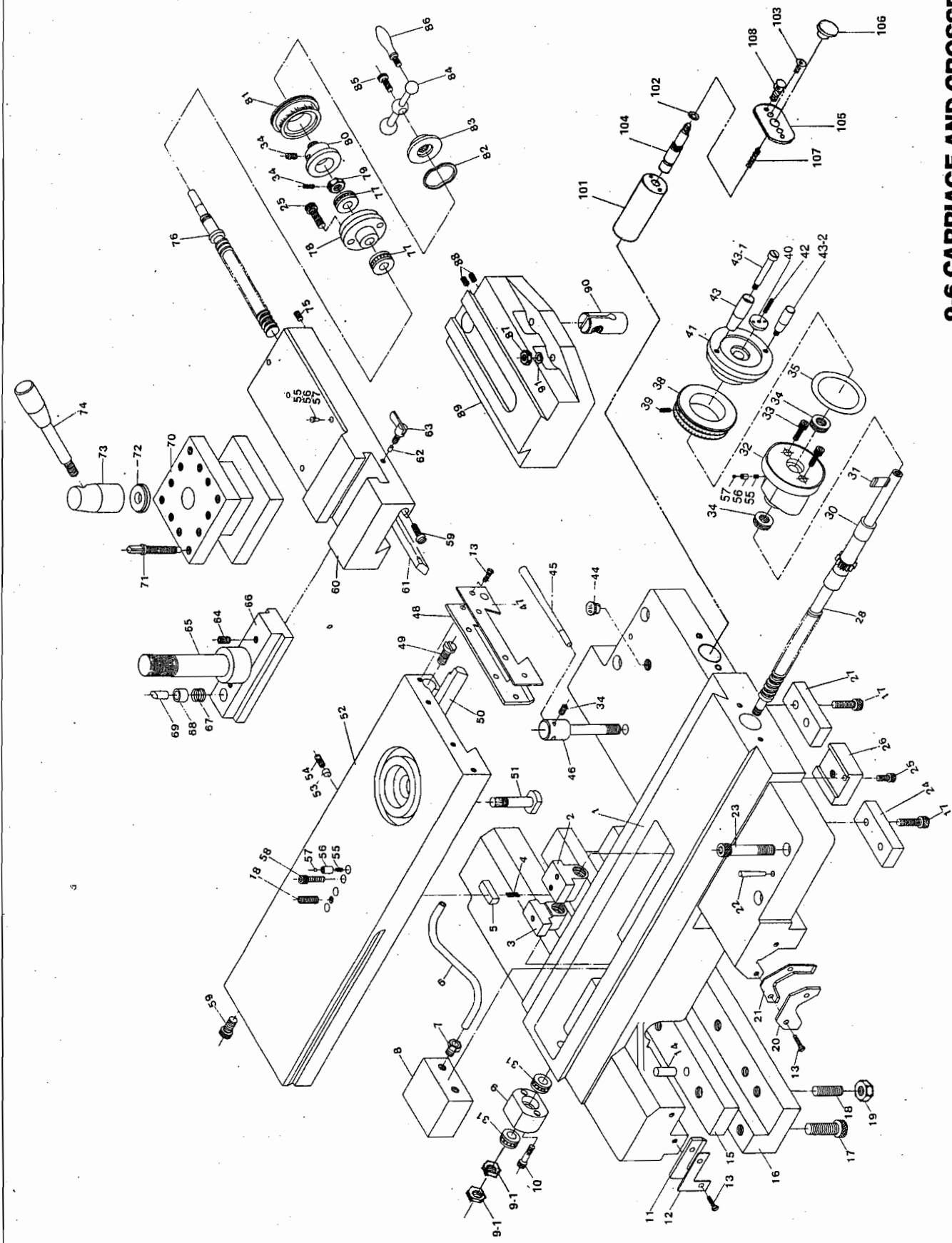

**9-6 CARRIAGE AND CROSSFEED**

3

# 9-6A CARRIAGE AND CROSSFEED

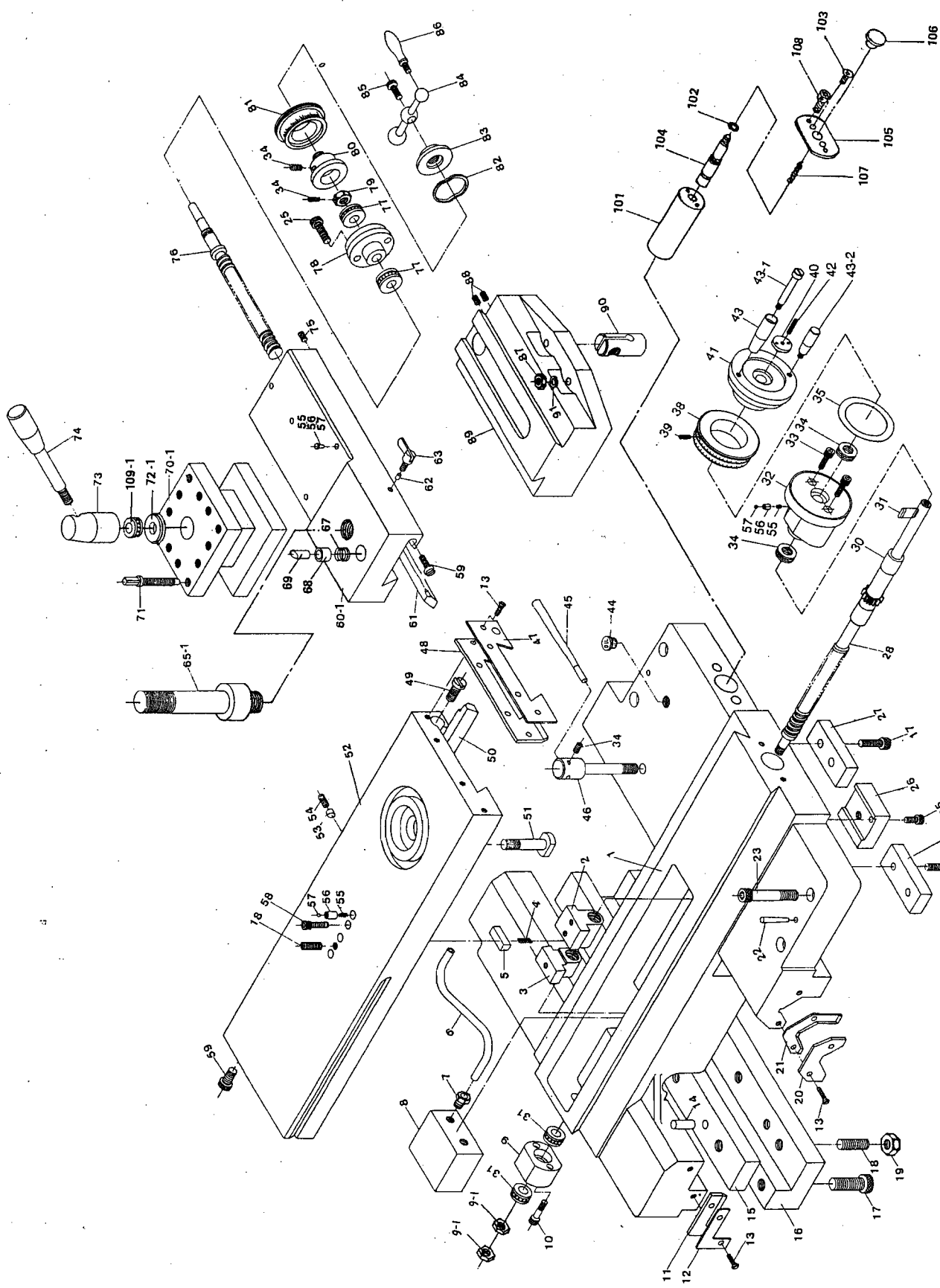

## CARRIAGE AND CROSSFEED ASSEMBLY

ITEM NO.	Part Name	Amt. Used	Type: 20. 22 Part No.	Type: 2280 Part No.	Type: 26 Part No.	Type:2680. 3080 Part No.	名稱
1	Carriage	1	1430800203	1430800203	153080022	154080012	滑座本體
2	Nut-crossfeed	1					螺帽
3	Nut-crossfeed	1					螺帽
4	Spring , 1x5x25L	1					彈簧
5	Shim-crossfeed nut	1	1120800901	1120800901	1120800901	1120800901	契
6	Pipe-lubrication oil	1					
7	Nut-copper	1					
8	Conveyor-oil	1	1120801006	1120801006	1120801006	1120801006	分油器
9	Cap-crossfeed screw	1	1120801104	1120801104	1120801104	1120801104	托架
9-1	Nut-hexa. head, M12xP1.25	2					六角螺帽
10	Hexagon socket screw, M6xP1.0x25L	2					六角承窩螺絲
11	Wiper-rear	1	1362100106	1362100106	1362100106	1362100106	右後防塵油封
12	Case-wiper , rear	1	1362100302	1362100302	1362100302	1362100302	後防塵油封固定片
13	Screw-cross-recessed, M4xP0.7x10L	8					十字圓頭螺絲
14	Pin	2					直銷
15	Gib	1	1430800302	1430800302	1430800302	1430800302	嵌條
16	Holder-gib	1	1430800704	1430800704	1430800704	1430800704	後扁栓
17	Hexagon socket screw, M8xP1.25x25L	4					六角承窩螺絲
18	Set screw, M8xP1.25x25L	4					固定螺絲
19	Nut , M8xP1.25	4					螺帽
20	Case-wiper , front	1	1362100400	1362100400	1362100400	1362100400	前防塵油封固定片
21	Wiper-front	1	1362100106	1362100106	1362100106	1362100106	防塵油封
22	Pin-taper , 6 # 75L	2	1420700500	1420700500	1420700500	1420700500	推拔銷
23	Hexagon socket screw, M10xP1.5x70L	4					六角承窩螺絲
24	Gib-left-front	1	1120801202	1120801202	1120801202	1120801202	左前扁栓
25	Set screw, M6xP1.0x16L	3					固定螺絲
26	Clamp-carriage	1	1120801300	1120801300	1120801300	1120801300	滑座夾緊塊
27	Gib-right-front	1	1120801408	1120801408	1120801408	1120801408	右前扁栓
28	Screw-crossfeed	1					導螺桿
	(5TPI , in)	1	1000801106	1000801508	1000801106	4006028-001	
	(5M/M , mm)	1	1000800805	1000801302	1000800805	1000801302	
30	Pinion-crossfeed (export)	1	1430801103	1540800601	1430801103	1540800601	齒輪軸
	(local)	1	1430801005	1540800503	1430801005	1540800503	
31	Bearing thrust, 51101	2	91303001	91303001	91303001	91303001	止推軸承
32	Bracket (export)	1	1430800106	1430800106	1430800106	1430800106	托架
	(local)	1	1430801603	1430801603	1430801603	1430801603	
33	Bolt-hexa. Socket , M8xP1.25x40L	2					六角承窩螺絲
34	Bearing thrust, 51104	2	91303003	91303003	91303003	91303003	固定螺絲
35	Washer-wave type , 6210	1					浪型墊圈

## CARRIAGE AND CROSSFEED ASSEMBLY

ITEM NO.	Part Name	Amt. Used	Type: 20. 22 Part No.	Type: 2280 Part No.	Type: 26 Part No.	Type:2680. 3080 Part No.	名稱
36	Set screw, M6xP1.0x10L	1					固定螺絲
37	Clutch-dial	1	1120802807	1120802807	1120802807	1120802807	測微規基座
38	Dial-crossfeed	1					刻度環
	(5TPI, in, export)	1	1000803806	1000803806	1000803806	1000803806	
	(5M/M, mm, export)	1	1000802701	1000802701	1000802701	1000802701	
39	Hexagon socket screw, M6xP1.0x15L	2					六角承窩螺絲
40	Nut-lock clutch	1	1120803108	1120803108	1120803108	1120803108	測微規基座
41	Handle (local)	1	1430801201	1430801201	1430801201	1430801201	手柄
	(export)	1	1430801309	1430801309	1430801309	1430801309	
42	Screw-adjusting, M6xP1.0x30L	1					止付螺絲
43	Knob-handle (local)	1	1430801201	1430801201	1430801201	1430801201	握把
	(export)	1	1430801505	1430801505	1430801505	1430801505	
43-1	Screw-handle (export)	1					
43-2	Knob-handle (export)	1	1120803402	1120803402	1120803402	1120803402	握把
44	Plug-oil inlet	1	1122103405	1122103405	1122103405	1122103405	油塞
45	Lever	1	1120801506	1120801506	1120801506	1120801506	固定把手
46	Screw-carriage clamp	1	1120800607	1430800606	1430800606	1430800606	固定螺栓
47	Case-wiper	1					
48	Wiper	1	1362101005	1362101005	1362101005	1362101005	橫滑座防塵油封
49	Screw-adjusting	1					調整螺栓
50	Gib	1	1540800307	1540800307	1540800307	1540800307	炭條
51	Bolt	4	1430800508	1430800508	1430800508	1430800508	特殊螺帽
52	Cover-cross sliding	1	143080091	143080091	143080091	143080091	橫滑座
53	Shoe-clamp	1	1220800707	1220800707	1220800707	1220800707	鎖緊銷
54	Set screw, M6xP1.0x20L	1					固定螺絲
55	Spring	5					彈簧
56	Sleeve	5					
57	Ball-steel, 1/4"	5					銅入珠
58	Hexagon socket screw, M6xP1.0x20L	3					六角承窩螺絲
59	Screw-gib	2	1120801702	1120801702	1120801702	1120801702	調整螺栓
60	Compound rest	1					刀具滑座
61	Gib-compound rest	1	1000804607	1000804607	1000804607	1000804607	船座炭條
62	Shoe-clamp	1	1220800709	1220800709	1220800709	1220800709	鎖緊銷
63	Screw-clamp	1					鎖緊螺絲
64	Hexagon socket screw, M8xP1.25x10L	4					
65	Shaft-tool post	1					刀架心軸
65-1	Shaft-tool post	1					刀架心軸
66	Block-tee	1					T型塊
67	Spring, 1x8x20L	1					彈簧
68	Sleeve	1					
69	Button	1					固定銷

## CARRIAGE AND CROSSFEED ASSEMBLY

ITEM NO.	Part Name	Amt. Used	Type: 20. 22 Part No.	Type: 2280 Part No.	Type: 26 Part No.	Type:2680. 3080 Part No.	名稱
70	Tool post-square (export)	1	1003518804	1003518804	1003518804	1003518804	四方刀架
	(local)	1	1003512900	1003512900	1003512900	1003512900	
71	Screw-square head	1	1000804205	1000804205	1000804205	1000804205	刀架螺絲
72	Bearing-thrust	1					止推軸承
73	Knob-lever	1					鎖緊輪
74	Lever	1					煙斗
75	Screw-gib, M8xP1.25x30L	1					
76	Screw compound rest	1					船座導螺桿
77	Bearing thrust, 51102	2					止推軸承
78	Seat-compound rest screw	1					
79	Nut	1					螺帽
80	Collar	1					
81	Dial-compound rest	1					船座刻度環
82	Washer-wave type	1					浪型墊圈
83	Nut	1					
84	Handle	1					手柄
85	Hexagon socket screw, M6xP1.0x16L	1					六角承窩螺絲
86	Knob-handle	1					手柄
87	Nut , M10xP1.5	4					螺帽
88	Set screw, M8xP1.25x8L	2					固定螺絲
89	Swivel	1					
90	Nut-compound rest screw	1					船座導螺桿螺帽
91	Spring washer , M10	4					彈簧墊圈
101	Body-pump	1	1120801800	1120801800	1120801800	1120801800	泵浦本體
102	Ring-O , PA10	1					O型環
103	Screw , M5xP0.8x12L	2					
104	Rod-pump	1	1120801908	1120801908	1120801908	1120801908	活塞桿
105	Stopper	1	1120802003	1120802003	1120802003	1120802003	固定板
106	Plug	1	1120802101	1120802101	1120802101	1120802101	把手
107	Spring-compressing, φ1.2x10x63L	1					彈簧
108	Screw hexa. Socket head cap, M6x10L	2	1120802209	1120802209	1120802209	1120802209	十字圓頭螺絲

# 9-7 TAIL STOCK

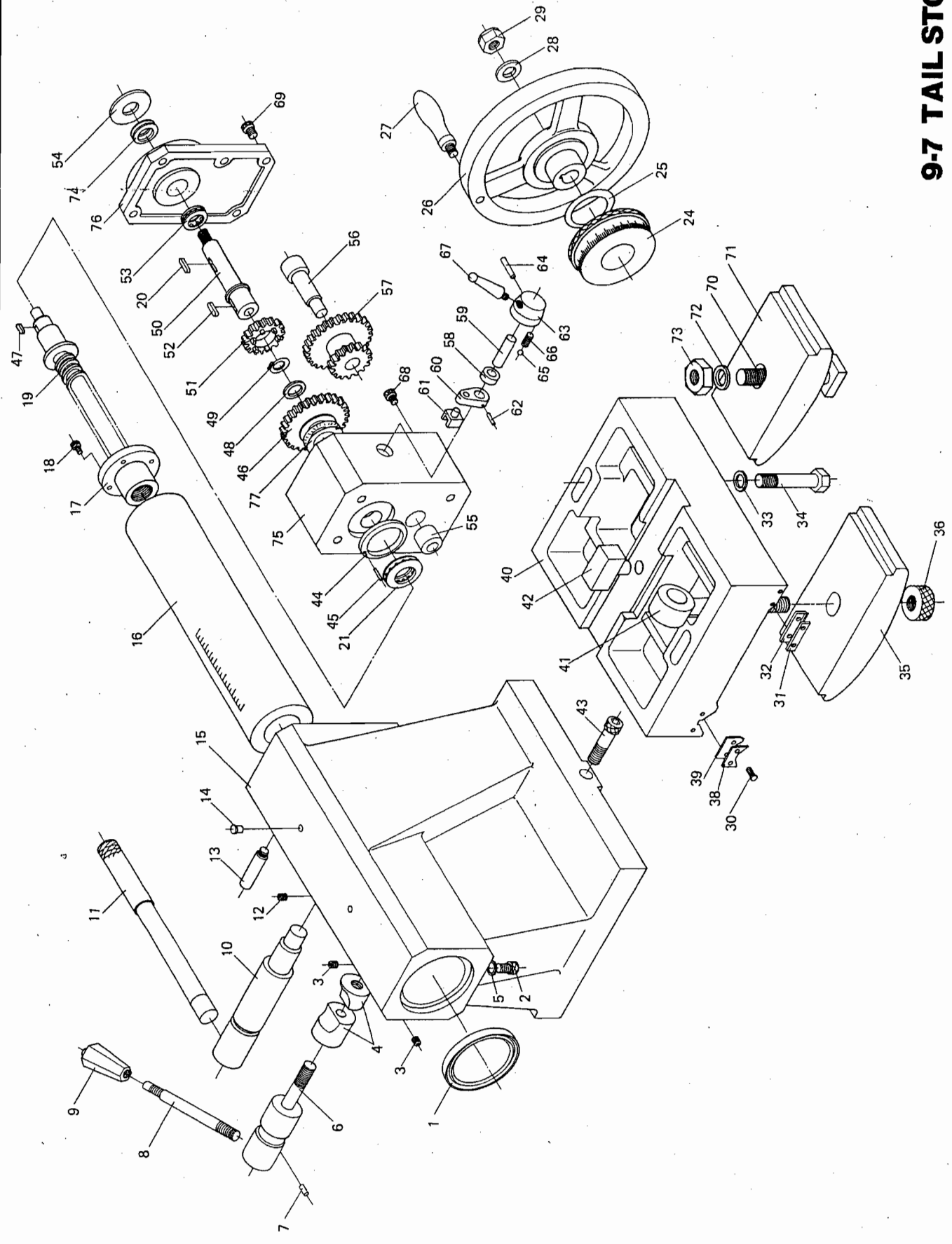



## TAILSTOCK ASSEMBLY

ITEM NO.	Part Name	Amt. Used	Type: 20GW Part No.	Type: 22 Part No.	Type: 26 Part No.	Type: 3080 Part No.	名稱
1	Seal-oil , TC75x90x8	1					油封
2	Hexagon socket screw, M8xP1.25x10L	1					六角承窩螺絲
3	Set screw, M6xP1.0x12L	1					固定螺絲
4	Block-clamp	1	1361101001	1361101001	1361101001	1441100500	鎖緊軸套
5	Spring washer , M12	1					彈簧墊圈
6	Shaft-clamp spindle	1	136110111	136110111	136110111	1441100608	鎖緊螺栓
7	Pin , 5x12	2					彈簧銷
8	Lever	1	1121102100	1121102100	1121102100	1121102100	手柄
9	Sleeve-lever	1	1120207400	1120207400	1120207400	1120207400	電木把手
10	Shaft-clamp botton	1	1361101207	1361101207	1361101207	1441100706	偏心軸柄
11	Lever	1	1361101207	1361101207	1361101207	1441100706	偏心軸柄
12	Set screw , M6xP1.0x20L	1					固定螺絲
13	Screw-brake	1	1121102306	1121102306	1121102306	1121102306	制動銷
14	Plug-oil , 1/4"	3					銅入珠
15	Body-tailstock	1					尾座本體
16	Spindle-tang slot	1	1361101305	1361101305	1361101305	144110081	套筒
17	Cap-spindle	1					銅螺帽
18	Hexagon socket screw, M6xP1.0x16L	4					六角承窩螺絲
19	Screw-spindle feed (in)	1	136110031	136110031	136110031	144110031	螺旋軸
	(mm)	1	136110041	136110041	136110041	144110041	
20	Key-square , 6x6x25	1					雙圓平行鍵
21	Bearing-thrust, 51205	1	91303006	91303006	91303006	91303006	止推軸承
24	Dial-feed (in)	1	1361100504	1361100504	1361100504	1361100504	刻度環
	(mm)	1	1361100602	1361100602	1361100602	1361100602	
25	Washer-wave type, WW-46	2					浪型墊圈
26	Handwheel	1	1361100906	1361100906	1361100906	1361100906	手輪
27	Knob	1	1121102002	1121102002	1121102002	1121102002	握把
28	Washer , W1/2"	1					平墊圈
29	Nut , 1/2"-20UNF	1					特殊螺帽
30	Screw-cross-recessed, M4xP0.7x10L	8					十字圓頭螺絲
31	Case-wiper	2	1362100508	1362100508	1362100508	1362101603	前防塵油封固定片
32	Wiper	2	1362100106	1362100106	1362100106	1432100305	防塵油封
33	Washer-flat , M12	2					平墊圈
34	Bolt-clamp, M12xP1.75.75L	2					六角頭螺絲
35	Clamp	1	1362100802	1362100802	1362100802	1442100102	制動塊
36	Nut	1	1362101505	1362101505	1362101505	1362101505	螺帽
38	Case	2	1362100302	1362100302	1362100302	1362100302	後防塵油封固定片
39	Wiper	2	1362100106	1362100106	1362100106	1432100305	防塵油封
40	Bottom-tailstock	1					尾座底板
41	Bolt-clamp	1	1361100700	1431100203	1541100306	9307041-4	環首螺栓
42	Blcok-adjusting	1	1221101301	1221101301	1221101301	1221101301	左右調整塊
43	Hexagon socket screw, M10xP1.5x80L	2					六角承窩螺絲

## TAILSTOCK ASSEMBLY

ITEM NO.	Part Name	Amt. Used	Type: 20GW Part No.	Type: 22 Part No.	Type: 26 Part No.	Type: 3080 Part No.	名稱
44	Socket washer	1	1361101805	1361101805	1361101805	1541100904	定位墊圈
45	Pin , $\phi 4 \times 22.5L$	1					
46	Clutch shaft	1	1361101903	1361101903	1361101903	1361101903	離合齒輪
47	Square key , 5x5x10L	1					雙圓平行鍵
48	Washer	1	1361102008	1361102008	1361102008	1361102008	墊圈
49	Snap ring , S18	1					
50	Clutch shaft	1	1361102106	1361102106	1361102106	1361102106	離合軸
51	Gear	1	1361102204	1361102204	1361102204	1361102204	齒輪
52	Square key , 5x5x25	1					雙圓平行鍵
53	Thrust bearing, 51104	1	91303003	91303003	91303003	91303003	止推軸承
54	Washer	1	1361102302	1361102302	1361102302	1361102302	墊圈
55	Spacer	1	1361102400	1361102400	1361102400	1361102400	套筒
56	Idle shaft	1	1361102508	1361102508	1361102508	1361102508	惰輪軸
57	Gear	1	1361102606	1361102606	1361102606	1361102606	中間齒輪
58	Spacer	1	1361102704	1361102704	1361102704	1361102704	套筒
59	Shaft	1	1361102802	1361102802	1361102802	1361102802	變速心軸
60	Shifting lever	1	1361102900	1361102900	1361102900	1361102900	搖臂
61	Shifting fork	1	1361103005	1361103005	1361103005	1361103005	撥爪
62	Spring pin , $\phi 4 \times 25L$	1					
63	Knob	1	1361103103	1361103103	1361103103	1361103103	變速把手
64	Spring pin , $\phi 5 \times 38L$	1					
65	Ball steel , $\phi 1/4"$	1					
66	Spring , D6xd1x20L	1					
67	Lever	1	1120207204	1120207204	1120207204	1120207204	把手
68	Hexagon socket screw, M8xP1.25x25L	4					六角承窩螺絲
69	Hexagon socket screw, M6xP1.0x16L	6					六角承窩螺絲
70	Bolt clamp	1	1432100207	1432100207	1432100207	1432100207	螺栓
71	Clamp	1	1362100802	1362100802	1362100802	1442100102	固定架制動塊
72	Washer , W3/4	1					
73	Nut , W3/4-10NC	1					
74	Ball bearing , 6004	1	91301006	91301006	91301006	91301006	滾珠軸承
75	Shifting box	1	1361101403	1361101403	1361101403	1441100902	變速箱
76	Shifting cover	1	1361103201	1361103201	1361103201	1441101007	變速箱蓋
77	Bearing thrust	1					

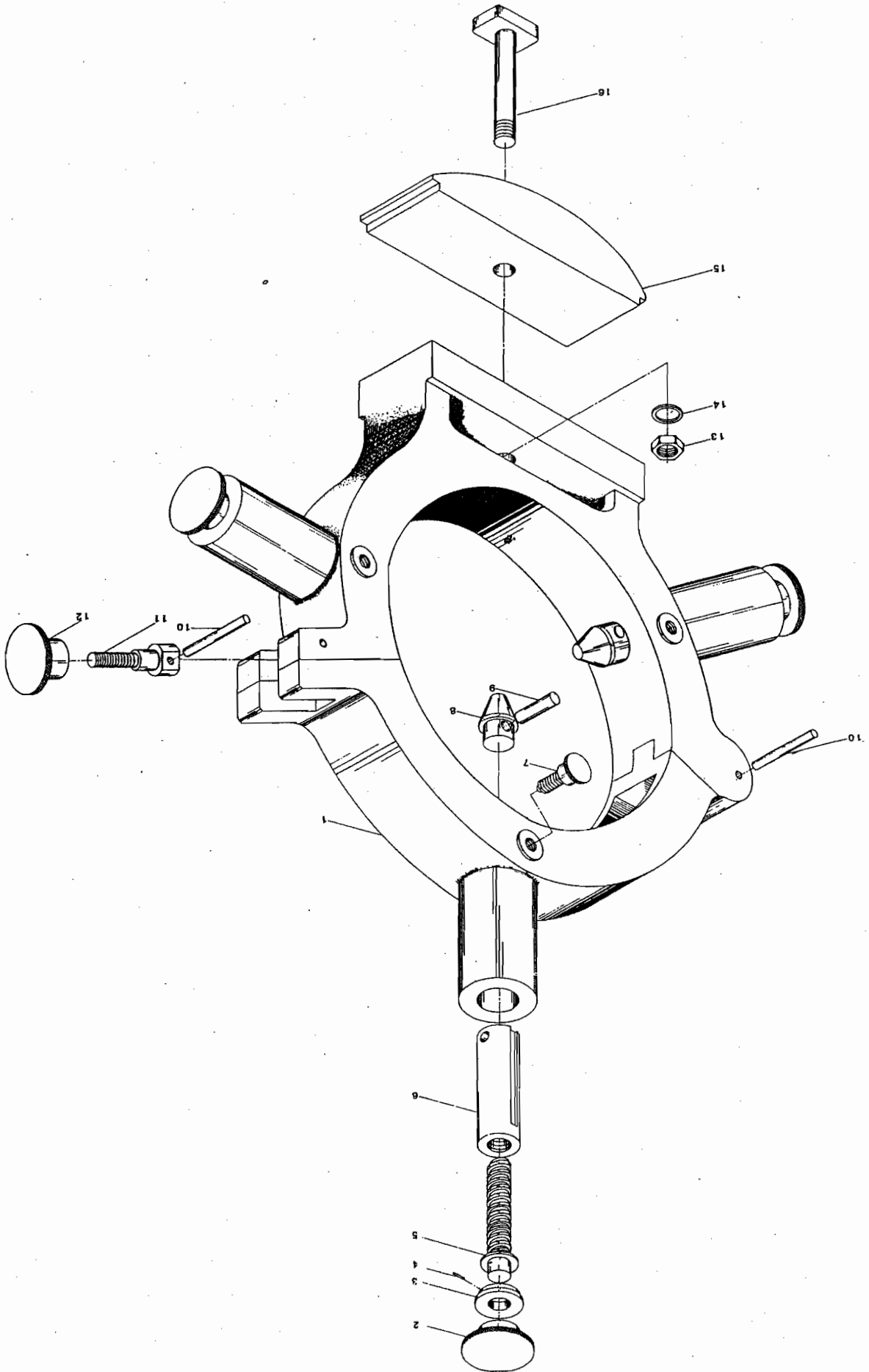

**9-8 STEADY REST**



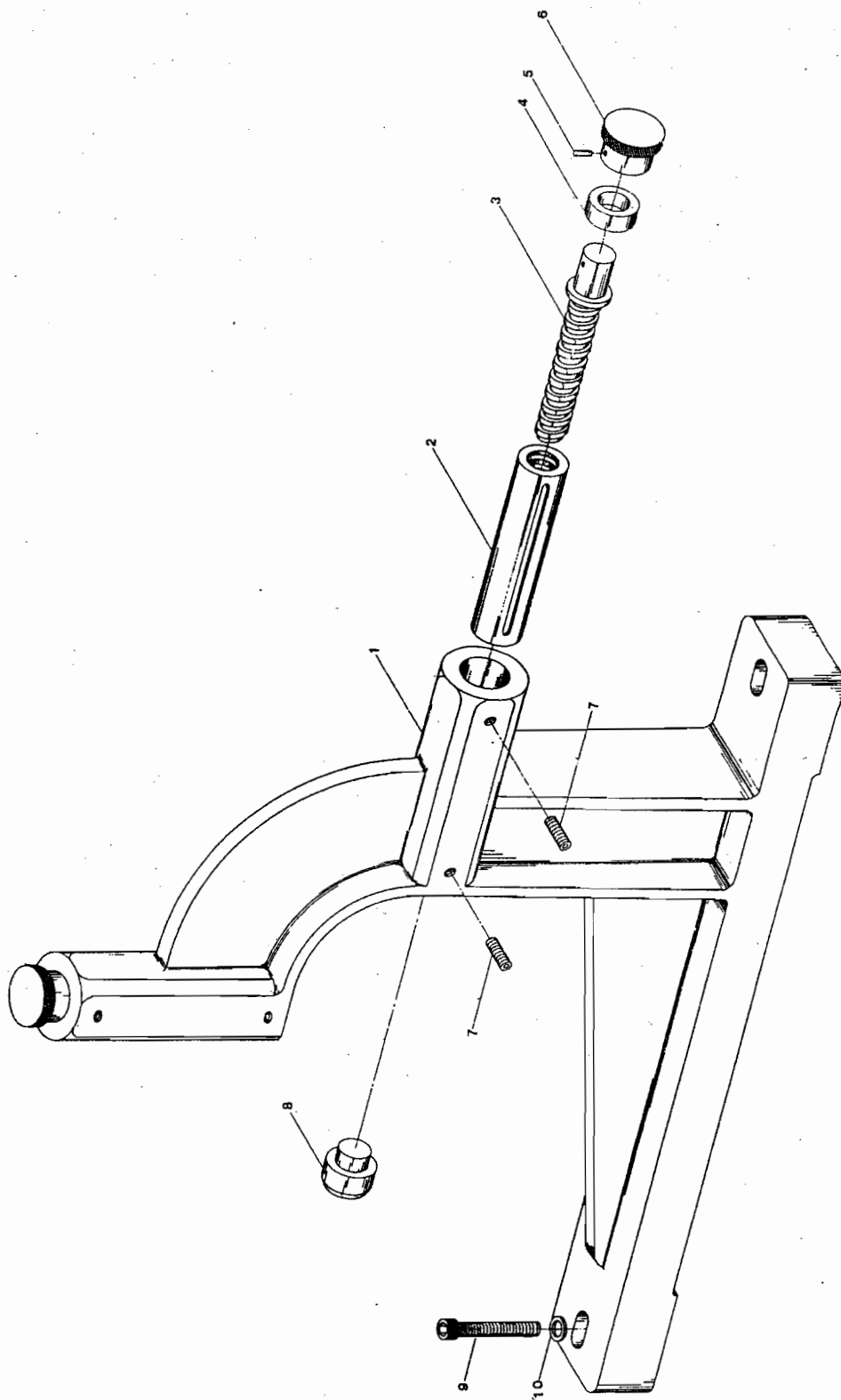

**9-9 FOLLOW REST**



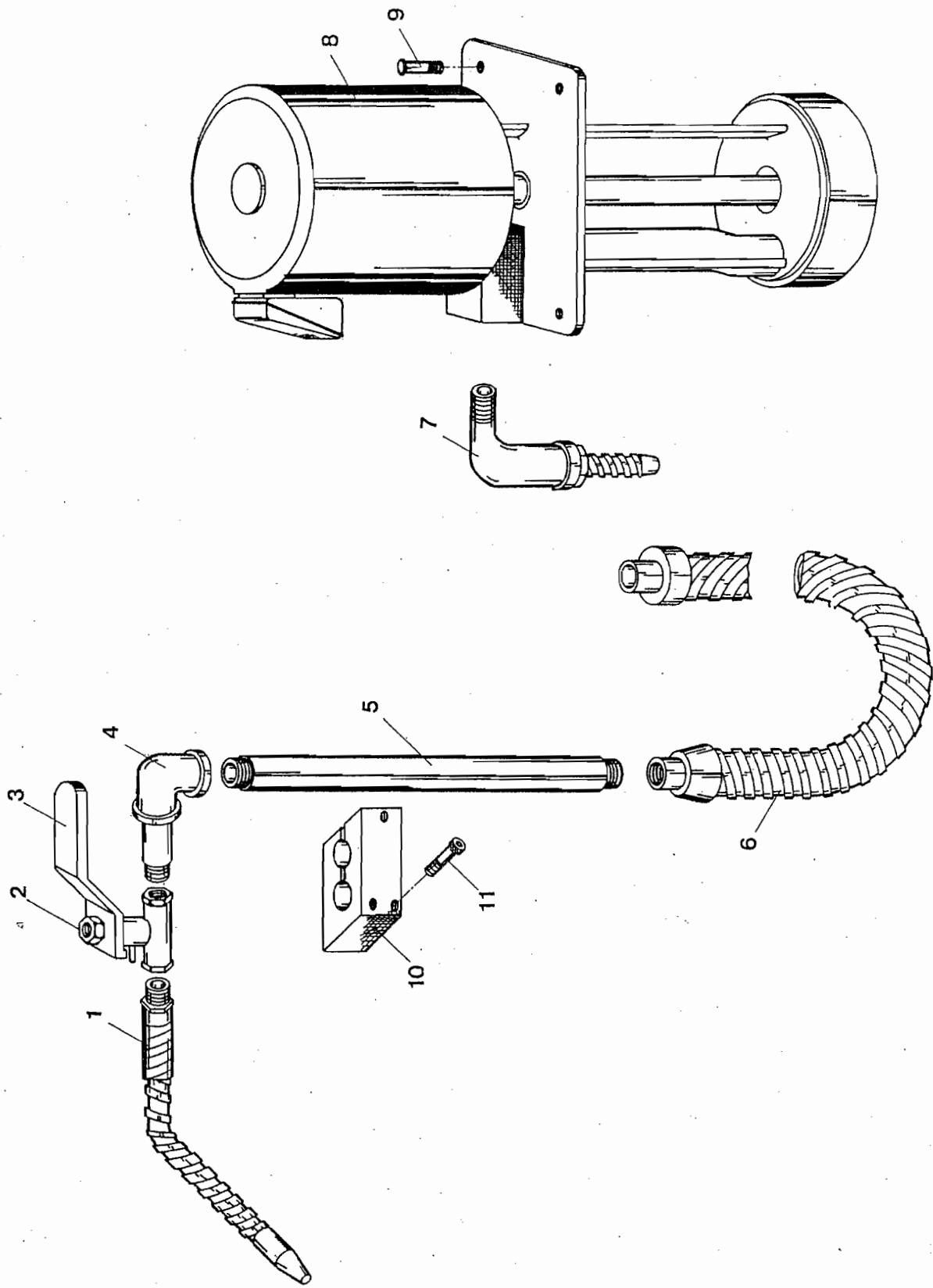

# 9-10 COOLANT SYSTEM

