

# ACER

## OPERATION MANUAL

### HIGH PRECISION

#### INVERTER DRIVE ENGINE LATHE

**MODEL:**    E-lathe 2140GH    E-lathe 2160GH  
                 E-lathe 2180GH    E-lathe 21120GH  
                 E-lathe 25" series

**TAIWAN: YA-GIN MACHINE TOOL MANUFACTURING INC.  
NO. 101, 506 LANE, SENG-TSO ROAD,  
SENG KARNG DISTRICT, TAICHUNG CITY, TAIWAN  
TEL: 886(4)2520-4120    FAX: 886 (4)2520-4123**

**NJ: KLIM INDUSTRIAL, INC.  
244 N. RANDOLPHVILLE ROAD  
PISCATAWAY, NJ 08854    USA  
TEL: (732)752-9100    FAX: (732)752-9101**

**CA: SPRINGWOOD INDUSTRIAL, INC.  
1062 N. KRAEMER PLACE  
ANAHEIM, CA 92806    USA  
TEL: (714)632-9701    FAX: (714)632-9730**

**Revised 8/29/13**

# CONTENT

|  | <b>Page #</b> |
|--|---------------|
| 1. CONTENT   | 1             |
| 2. SAFETY OF OPERATION RULES                                 | 5             |
| 3. SPECIFICATIONS  | 7             |
| 4. DESCRIPTION OF MACHINE COMPONENTS                         | 10            |
| 5. NOTES BEFORE OPERATION                                    | 11            |
| 6. UNPACKING   | 11            |
| 7. MOVING & LIFTING  | 11            |
| 8. FOUNDATIONS   | 13            |
| 9. LEVELING THE MACHINE                                      | 13            |
| Foundation map   | 14            |
| 10. CLEAN UP   | 15            |
| 11. ELECTRICAL POWER CONNECTION                              | 15            |
| 12. CAUTIONS   | 15            |
| 13. ELECTRICAL & CIRCUIT DIAGRAM                             | 16            |
| a. E-lathe (SPEED CHANGE: 3 STEPS)                           | 17            |
| b. Electrical Diagram & Its Circuit                          | 18            |
| c. Control Panel Layout                                      | 21            |
| d. Layout of Electrical Cabinet                              | 22            |
| e. Electrical Component List                                 | 23            |
| f. E-lathe (SPEED CHANGE: 3 STEPS) + Z AXIS RAPID TRAVEL     | 24            |
| g. Electrical Diagram & Its Circuit                          | 25            |
| h. Control Panel Layout                                      | 29            |
| i. Layout of Electrical Cabinet                              | 30            |
| j. Electrical Component List                                 | 31            |
| 14. ELECTRICAL CIRCUIT DIAGRAM FOR CE REQUIREMENT            | 33            |
| a. CE Inverter Type Lathe (SPEED CHANGE: 3 STEP)             | 34            |
| b. Control Panel Layout                                      | 34            |
| c. Layout of Electrical Cabinet                              | 35            |
| d. Electrical Diagram & Its Circuit                          | 36            |
| e. Electrical Component List                                 | 40            |
| 15. OPERATION  | 41            |
| 16. HEAVY DUTY PRECISION LATHE (WITH INVERTER)               | 42            |
| 17. SPINDLE SPEED SELECTION, STOP & RE-START (WITH INVERTER) | 43            |
| 18. CAUTIONS   | 44            |
| 19. HOW TO OPERATION THE JOGGING SWITCH                      | 44            |
| 20. GEAR CHANGE SYSTEM                                       | 44            |

|   |     |
|---|-----|
| 21. HOW TO OPERATE THE CARRIAGE & APRON                 | 44  |
| 22. MANUAL FEED   | 44  |
| 23. AUTO FEED   | 45  |
| 24. SWIVELING THE TOOL POST                             | 45  |
| 25. THREAD CHART  | 47  |
| 26. HOW TO OPERATE THE LEADSCREW                        | 48  |
| 27. METRIC/INCH THREAD SYSTEM                           | 48  |
| 28. THREAD CUTTING CHART                                | 48  |
| 29. OPERATION OF SPINDLE                                | 50  |
| SELECTING SPINDLE SPEED (LATHE WITH INVERTER CONTROL)   | 50  |
| STOP AND RE-START SPINDLE (LATHE WITH INVERTER CONTROL) | 51  |
| OPERATION INSTRUCTION FOR AUTOMATIC SPEED CHANGE        | 52  |
| CALCULATING SPINDLE SPEED                               | 52  |
| 30. BENEFIT OF USING TAPER TURNING ATTACHMENT           | 53  |
| OPERATION OF TAPER TURNING ATTACHMENT                   | 54  |
| 31. LUBRICATION   | 55  |
| OIL INLET POINTS  | 56  |
| LUBRICATION SCHEDULE                                    | 57  |
| 32. TROUBLE CAUSE & TROUBLE SHOOTING                    | 58  |
| 33. ADJUSTMENT OF MACHINE COMPONENTS                    | 59  |
| A. Spindle Headstock Adjustment                         | 59  |
| B. V-belt of Spindle                                    | 61  |
| C. Adjustment of Crossfeed Leadscrew                    | 62  |
| D. Adjustment of Saddle Gib                             | 63  |
| E. Adjustment of the gib between Saddle and Cross-slide | 64  |
| 34. REPLACEABLE COMPONENTS ON THE MACHINE               | 65  |
| 35. MECHANICAL DRAWINGS & PART BREAKDOWN LIST           | 66  |
| INVERTER LATHE  | 67  |
| HEADSTOCK 21/25HC, SPINDLE BORE 85MM (3")               | 67  |
| HEADSTOCK 21/25HC, SPINDLE BORE 105MM (4")              | 73  |
| HEADSTOCK 25HC, SPINDLE BORE 155MM (6")                 | 79  |
| CHANGE GEAR (END GEAR)                                  | 85  |
| PART LIST OF BED- 21/25B                                | 87  |
| PART LIST OF CARRIAGE- 21/25S                           | 94  |
| TOOL POST   | 98  |
| PART LIST OF ARPON-21/25A                               | 99  |
| PART OF LIST 20G FEED GEARBOX                           | 105 |
| PART LIST OF TAILSTOCK 18/21/25T                        | 111 |

|                                |     |
|--------------------------------|-----|
| STEADY REST .....              | 115 |
| FOLLOW REST .....              | 117 |
| TAPER TURNING ATTACHMENT ..... | 118 |

## **IMPORTANT**

**DO NOT OPERATE, PROGRAM OR REPAIR THE  
MACHINE UNTIL YOU HAVE READ THIS MANUAL  
DETAILEDLY!**

**DO NOT OPERATE, PROGRAM OR REPAIR THE  
MACHINE UNTIL YOU HAVE READ THE  
APPROPRIATE MANUALS!**

**NOTE : A SAFETY MANUAL MUST REMAIN ATTACHED TO THE MACHINE  
AT ALL TIMES.**

## **SAFETY OF OPERATION RULES**

1. **SECURE WORK.** Use chuck to hold work piece when practical. It's safer than using your hand and it frees both hands to operate tool.
2. **DON'T OVERREACH.** Keep proper footing and balance at all times.
3. **MAINTAIN TOOLS WITH CARE.** Keep tools sharp and clean for the best and the safest performance. Follow instructions for lubricating and changing accessories.
4. **DISCONNECT TOOLS** before servicing, when changing accessories such as cutting tools.
5. **REDUCE THE RISK OF UNINTENTIONAL STARTING.** Make sure switch is in off position, before intended plugged in.
6. **USE RECOMMENDED ACCESSORIES.** Consult the owner's manual for recommended accessories. The use of improper accessories may cause risk or injury to persons.
7. **NEVER STAND ON TOOL.** Serious injury could occur, if the tool is tipped or if the cutting tool is unintentionally contacted.
8. **CHECK DAMAGE PARTS.** Before further use of the tool, a guard or other part that is damaged should be carefully checked to determine that it will operate properly and perform its intended function, check for alignment of moving part binding of moving parts, breakage of parts, mounting, and any other conditions that may affect its operation. A guard or other part that is damaged should be properly repaired or replaced.
9. **NEVER LEAVE TOOL RUNNING UNATTENDED TURN POWER OFF.** Don't leave tool until it comes to a complete stop.
10. **ALWAYS USE SAFETY GLASSES.** Common eyeglasses only have impact resistant lenses, they are NOT safety glasses.
11. **KEEP GUARDS IN PLACE** and in working order.
12. **REMOVE ADJUSTING KEYS AND WRENCHES.** Form habit of checking to see that keys and adjusting wrenches are removed from tool before turning it on.
13. **KEEP WORK AREA CLEAN.** Cluttered areas will invite accidents.
14. **DON'T USE IN DANGEROUS ENVIRONMENT.** Don't use power tools in damp or wet location, or expose them to rain. Keep work area well lighted.
15. **KEEP CHILDREN AWAY.** All visitors should be kept safe distance from work area.
16. **MAKE WORKSHOP CHILD PROOF** with padlocks, master switches, or by removing starter keys.
17. **DON'T FORCE TOOL USAGE.** Don't force tool or attachment to do a job for which it was not designed.
18. **USE THE RIGHT TOOL.** It will do the job better and safer at the rate for which it was designed.
19. **WEAR PROPER APPAREL.** No loose clothing, gloves, neckties, rings bracelets, or other jewelry to get caught in moving parts. Non-slip footwear is recommended, wear protective hair covering to contain long hair.

20. Never use the high speed on spindle over one hour.
21. KEEP TURNING TOOLS TIGHT during operating.

## SPECIFICATIONS

Specifications of machine

| MODEL                       | E-lathe | 1840GH                         | 1860GH   | 1880GH   |
|-----------------------------|---------|--------------------------------|--|----------|
| <b>General Capacity</b>     |         |                                |  |          |
| Center height               |         | 230 mm                         |  |          |
| Max. swing over bed         |         | 460 mm                         |  |          |
| Max. swing over gap         |         | 640 mm (opt.)                  |  |          |
| Max. swing over cross slide |         | 290 mm                         |  |          |
| Distance Bedween centers    |         | 1000 mm                        | 1500 mm  | 2000 mm  |
| <b>Main Spindle</b>         |         |                                |  |          |
| Spindle nose                |         | D1-6                           |  |          |
| Spindle bore                |         | 56 mm(2")                      |  |          |
| Spindle speeds              |         | Conventional type, 39~2800 RPM |  |          |
|                             |         | Inverter type,<br>(opt.)       | H: 3100~681 RPM<br>M: 680~153 RPM<br>L: 152~33 RPM |          |
| <b>Carriage</b>             |         |                                |  |          |
| Gross slide travel          |         | 280 mm                         |  |          |
| Compound rest travel        |         | 120 mm                         |  |          |
| Tailstock                   |         |                                |  |          |
| Tailstock spindle dia.      |         | 75 mm                          |  |          |
| Tailstock spindle travel    |         | 170 mm                         |  |          |
| Tailstock spindle taper     |         | MT#5                           |  |          |
| <b>Bed</b>                  |         |                                |  |          |
| Bed width                   |         | 350 mm                         |  |          |
| <b>Threading</b>            |         |                                |  |          |
| Lead screw                  |         | 4 TPI or 6 mm/pitch            |  |          |
| Metric pitch threads        |         | 0.5-7 mm/pitch (24 kinds)      |  |          |
| Inch threads                |         | 4-56 TPI (36 kinds)            |  |          |
| Module pitch threads        |         | 0.25-3.5 M (16 kinds)          |  |          |
| DP threads                  |         | 8-112 P (36 kinds)             |  |          |
| <b>Feeding Range</b>        |         |                                |  |          |
| Range of longitudinal feeds |         | 0.06-0.88 mm/rev               |  |          |
| Range of cross feeds        |         | 0.03-0.44 mm/rev               |  |          |
| <b>Motor</b>                |         |                                |  |          |
| Main spindle motor          |         | 7.5 HP / 10 HP (opt.)          |  |          |
| Coolant pump motor          |         | 1/8 HP                         |  |          |
| N.W. Approx.                |         | 2000 kgs                       | 2250 kgs   | 2500 kgs |
| G.W. Approx.                |         | 2200 kgs                       | 25200 kgs  | 2830 kgs |

Note : We have the right to modify the specifications or designs. If there are subjected to change, without prior notice.



| MODEL                       | E-lathe   | 2140GH   | 2160GH  | 2180GH   | 21120GH |
|-----------------------------|---|----------|---|----------|---------|
| <b>General Capacity</b>     |   |          |   |          |         |
| Center height               | 270 mm  |          |   |          |         |
| Max. swing over bed         | 540 mm  |          |   |          |         |
| Max. swing over gap         | 720 mm (opt.)   |          |   |          |         |
| Max. swing over cross slide | 360 mm  |          |   |          |         |
| Distance Bedween centers    | 1000 mm   | 1500 mm  | 2000 mm   | 3000 mm  |         |
| <b>Main Spindle</b>         |   |          |   |          |         |
| Spindle nose                | D1-8  |          | A2-11   |          |         |
| Spindle bore                | 85 mm(3")   |          | 105 mm(4")  |          |         |
| Spindle speeds              | Conventional type,<br>25~1545 RPM   |          | Conventional type,<br>23~1293 RPM   |          |         |
|                             | Inverter type, (opt.)<br>H: 2250~491 RPM<br>M: 490~126 RPM<br>L: 125~27 RPM |          | Inverter type, (opt.)<br>H: 1500~331 RPM<br>M: 330~93 RPM<br>L: 92~20 RPM |          |         |
| <b>Carriage</b>             |   |          |   |          |         |
| Gross slide travel          | 330 mm  |          |   |          |         |
| Compound rest travel        | 150 mm  |          |   |          |         |
| Tailstock                   |   |          |   |          |         |
| Tailstock spindle dia.      | 75 mm   |          |   |          |         |
| Tailstock spindle travel    | 170 mm  |          |   |          |         |
| Tailstock spindle taper     | MT#5  |          |   |          |         |
| <b>Bed</b>                  |   |          |   |          |         |
| Bed width                   | 350 mm  |          |   |          |         |
| <b>Threading</b>            |   |          |   |          |         |
| Lead screw                  | 4 TPI or 6 mm/pitch   |          |   |          |         |
| Metric pitch threads        | 0.5-7 mm/pitch (24 kinds)   |          |   |          |         |
| Inch threads                | 4-56 TPI (36 kinds)   |          |   |          |         |
| Module pitch threads        | 0.25-3.5 M (16 kinds)   |          |   |          |         |
| DP threads                  | 8-112 P (36 kinds)  |          |   |          |         |
| <b>Feeding Range</b>        |   |          |   |          |         |
| Range of longitudinal feeds | 0.06-0.88 mm/rev (36 kinds)   |          |   |          |         |
| Range of cross feeds        | 0.03-0.44 mm/rev (36 kinds)   |          |   |          |         |
| <b>Motor</b>                |   |          |   |          |         |
| Main spindle motor          | 10 HP / 15 HP (opt.)  |          |   |          |         |
| Coolant pump motor          | 1/8 HP  |          |   |          |         |
| N.W. Approx.                | 2200 kgs  | 2350 kgs | 2600 kgs  | 2600 kgs |         |
| G.W. Approx.                | 2400 kgs  | 2620 kgs | 2930 kgs  | 3200 kgs |         |

Note : We have the right to modify the specifications or designs. If there are subjected to change, without prior notice.

| MODEL                       | E-lathe  | 2540GH   | 2560GH   | 2580GH  | 25120GH |
|-----------------------------|--|--|----------|---|---------|
| <b>General Capacity</b>     |  |  |          |   |         |
| Center height               | 315 mm   |  |          |   |         |
| Max. swing over bed         | 630 mm   |  |          |   |         |
| Max. swing over gap         | 810 mm (opt.)  |  |          |   |         |
| Max. swing over cross slide | 450 mm   |  |          |   |         |
| Distance Bedween centers    | 1000 mm  | 1500 mm  | 2000 mm  | 3000 mm   |         |
| <b>Main Spindle</b>         |  |  |          |   |         |
| Spindle nose                | D1-8   | A2-11  |          | A2-11   |         |
| Spindle bore                | 85 mm(3")  | 105 mm(4") opt.  |          | 155 mm(6") opt.   |         |
| Spindle speeds              | Conventional type,<br>25~1545 RPM  | Conventional type,<br>23~1293 RPM  |          | Conventional type,<br>15~840 RPM  |         |
|                             | Inverter type (opt.)<br>H: 2250~491 RPM<br>M: 490~126 RPM<br>L: 125~27 RPM | Inverter type (opt.)<br>H: 1500~331 RPM<br>M: 330~93 RPM<br>L: 92~20 RPM |          | Inverter type (opt.)<br>H: 800~176 RPM<br>M: 175~53 RPM<br>L: 52~10 RPM |         |
| <b>Carriage</b>             |  |  |          |   |         |
| Gross slide travel          | 330 mm   |  |          |   |         |
| Compound rest travel        | 150 mm   |  |          |   |         |
| Tailstock                   |  |  |          |   |         |
| Tailstock spindle dia.      | 75 mm  |  |          |   |         |
| Tailstock spindle travel    | 170 mm   |  |          |   |         |
| Tailstock spindle taper     | MT#5   |  |          |   |         |
| <b>Bed</b>                  |  |  |          |   |         |
| Bed width                   | 350 mm   |  |          |   |         |
| <b>Threading</b>            |  |  |          |   |         |
| Lead screw                  | 4 TPI or 6 mm/pitch  |  |          |   |         |
| Metric pitch threads        | 0.5-7 mm/pitch (24 kinds)  |  |          |   |         |
| Inch threads                | 4-56 TPI (36 kinds)  |  |          |   |         |
| Module pitch threads        | 0.25-3.5 M (16 kinds)  |  |          |   |         |
| DP threads                  | 8-112 P (36 kinds)   |  |          |   |         |
| <b>Feeding Range</b>        |  |  |          |   |         |
| Range of longitudinal feeds | 0.06-0.88 mm/rev (36 kinds)  |  |          |   |         |
| Range of cross feeds        | 0.03-0.44 mm/rev (36 kinds)  |  |          |   |         |
| <b>Motor</b>                |  |  |          |   |         |
| Main spindle motor          | 10 HP / 15 HP (opt.)   |  |          |   |         |
| Coolant pump motor          | 1/8 HP   |  |          |   |         |
| N.W. Approx.                | 2250 kgs   | 2400 kgs   | 2650 kgs | 2650 kgs  |         |
| G.W. Approx.                | 2450 kgs   | 2670 kgs   | 2980 kgs | 3250 kgs  |         |

Note : We have the right to modify the specifications or designs. If there are subjected to change, without prior notice.

# DESCRIPTION OF MACHINE COMPONENTS

## Inverter Series Description of Machine

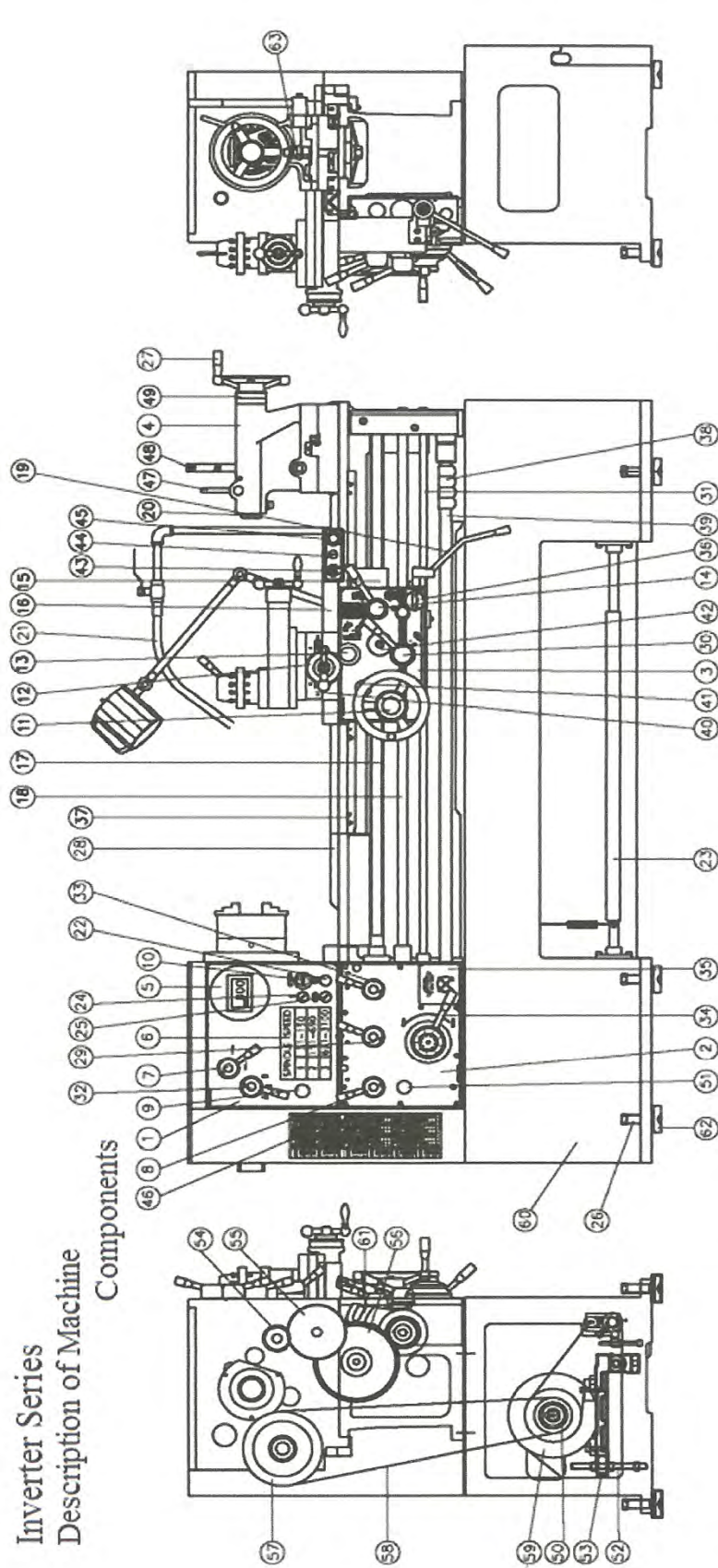

### Components

- |                            |  |                               |                                   |                                   |                            |                           |
|----------------------------|--|-------------------------------|-----------------------------------|-----------------------------------|----------------------------|---------------------------|
| 1. Headstock               | 11. Longitudinal handwheel             | 21. Coolant nozzle            | 31. Spindle lever location rod    | 41. Apron oil gauge               | 51. Gear box gauge         | 61. Bracket               |
| 2. Gear box                | 12. Crossfeed handwheel                | 22. Jog button                | 32. Spindle speed selection lever | 42. Anti-slip mechanism           | 52. Adjustment screw       | 62. Leveling pads         |
| 3. Apron                   | 13. Long/Cross feeding selection lever | 23. Brake pedal               | 33. Feed selection lever          | 43. Speed turning knob            | 53. Motor posi. plate      | 63. Tailstock locking nut |
| 4. Tailstock               | 14. Half-nut engagement lever          | 24. Power on/off switch       | 34. Feed selection dial/lever     | 44. Speed selection switch        | 54. Idle (end) gear        |                           |
| 5. RPM meter               | 15. Thread chasing dial                | 25. Coolant on/off switch     | 35. Micro-limit switch            | 45. Emergency switch              | 55. Idle (end) gear large  |                           |
| 6. RPM speed chart         | 16. Saddle                             | 26. Leveling screw            | 36. Apron lube pump handle        | 46. Feed selection chart          | 56. Double-stack idle gear |                           |
| 7. Feed directional lever  | 17. Feed screw                         | 27. Tailstock quill handwheel | 37. Gear racks                    | 47. Quill locking lever           | 57. Spindle pulley         |                           |
| 8. Feed selection lever    | 18. Leadscrew for threading            | 28. Gap                       | 38. Multi-position stop collar    | 48. Tailstock posi. locking lever | 58. V belts                |                           |
| 9. Oil gauge for headstock | 19. Spindle rotation selection lever   | 29. Feed selection lever      | 39. Multi-position stop rod       | 49. Tailstock dial                | 59. Spindle motor          |                           |
| 10. Emergency switch       | 20. Quill for tailstock                | 30. Feed engagement lever     | 40. Cross-slide                   | 50. Motor pulley                  | 60. Machine base           |                           |

## NOTES BEFORE OPERATION

### UNPACKING

After unpacking the transporting wooden case which must inspected the machine carefully. If there are any shortages or damages on the package, please contact your local dealer immediately.

### MOVING & LIFTING

Moving and lifting the machine by using a special hang fixture as shown on the figures and insert the special hang fixture in between the bedways of the machine. Raising and lowering the machine must be careful. Do not press the lead screw, spindle or other hand wheels etc. Be careful not to bump the machine against the floor! Before moving the machine, please check the following areas:

1. Locked & clamped the tailstock.
2. Locked the saddle lock.
3. Engaged half-nut with leadscrew.

Please use the following equipment to lift the machine.

1. An overhead crane which the safety loading weight is rated more than the machine weight itself, and a special hand fixture for machine lifting. (shown in figure 1)
2. Two safety straps with width of 80 mm, thickness of 6 mm and length of 4000mm. The safety loading weight of the straps is required same as the crane's. Wrap the straps under the ribs as shown, and then lift the machine in the slowest speed of the overhead crane. (shown in figure 2)

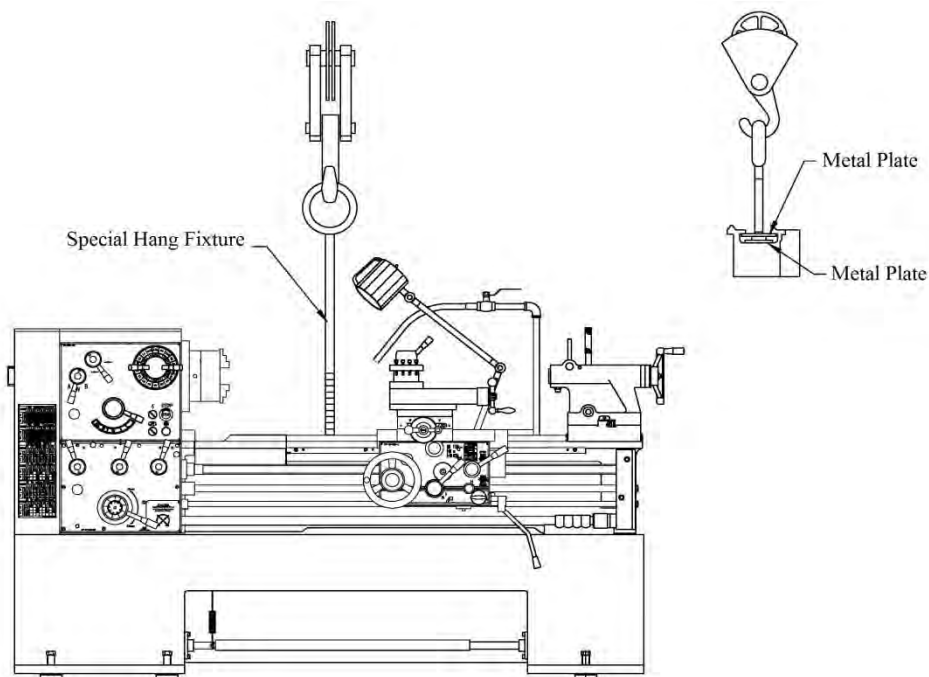

Figure 1

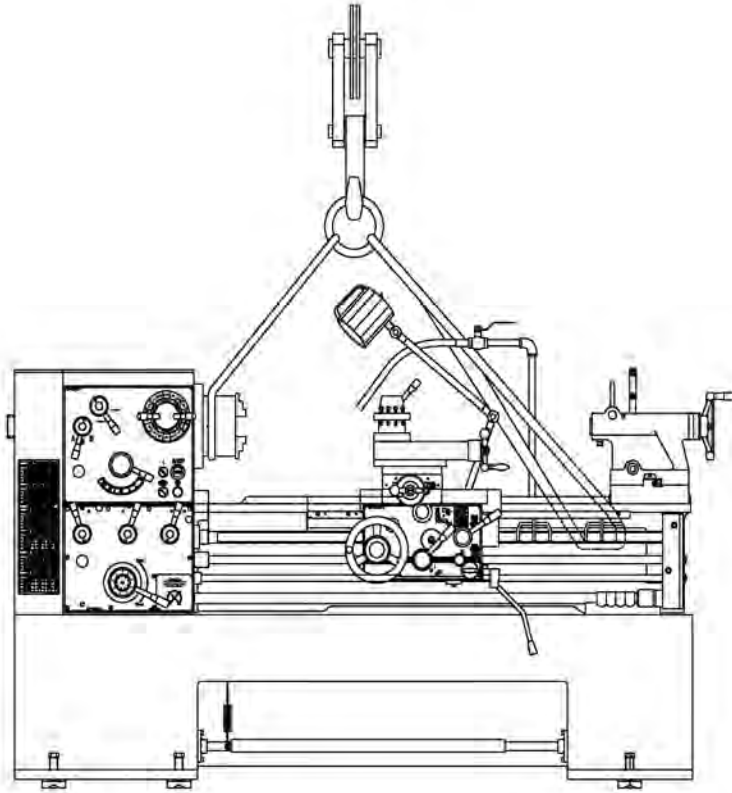

Figure 2

**Note:**

1. Machine must always be kept balanced during lifting.
2. Place protection material on any part of the machine that might be contacted by straps or metal plate.
3. Take the machine weight (refer to catalog) into consideration to determine the forklift or overhead crane's capacity.

## FOUNDATIONS

Due to the cutting speed and spindle speed are much higher than before, it is recommended to have a foundation done for the machine. The reasoning being an incomplete foundation will allow the machine to generate vibration and create an unstable condition. Since the foundation work should be done, an enough space and boundary are necessary for the machine to operate. It is recommended to install the machine at least 3 ft from the wall and from other machines.

## LEVELING THE MACHINE

Anchor bolts and installation blocks must be fixed steadily into the cement. For alignment of the machine, please the square leveling gauge on the guide way of bed (The precision of the level should be 0.02mm/1000mm or more better) and measure the levelness of the bedways from left to right, so as to adjust the saddle, from both front and rear of the machines. Make sure the sensitivity range is within 0.04mm/1000mm.

After the leveling procedures are completed, fasten the foundation nuts. If the flatness has deviated by fastening nuts, then the machine must be re-level and re-measure, re-tightening the nuts again until no deviation is found!

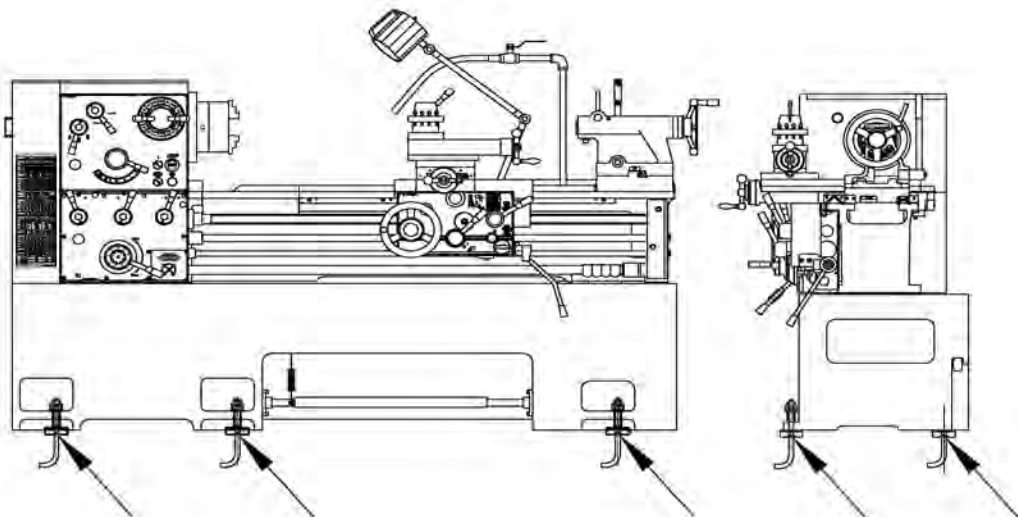
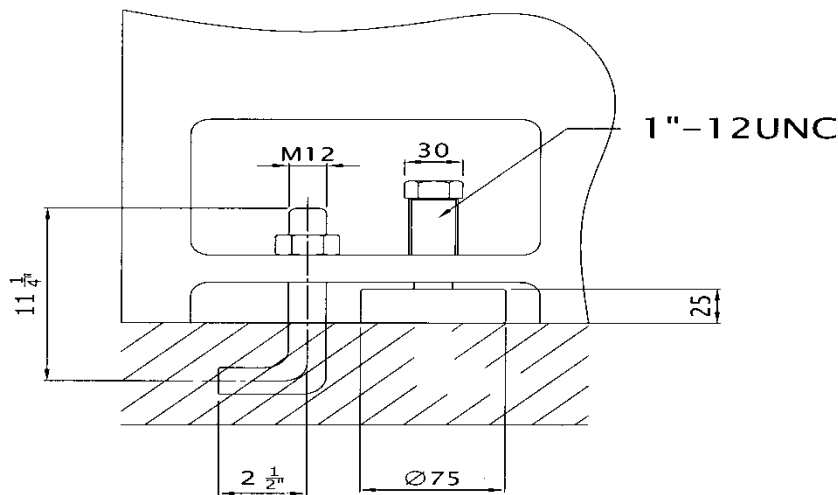

Foundation  
map

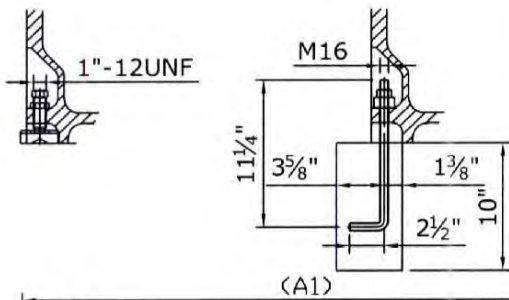
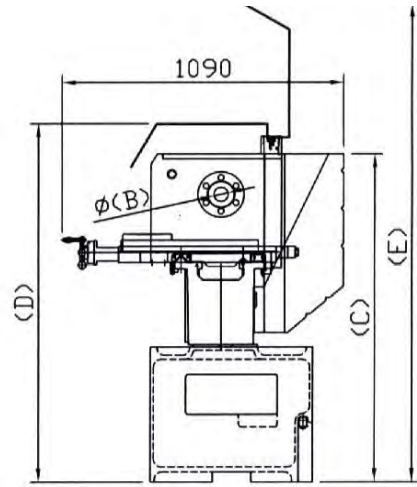
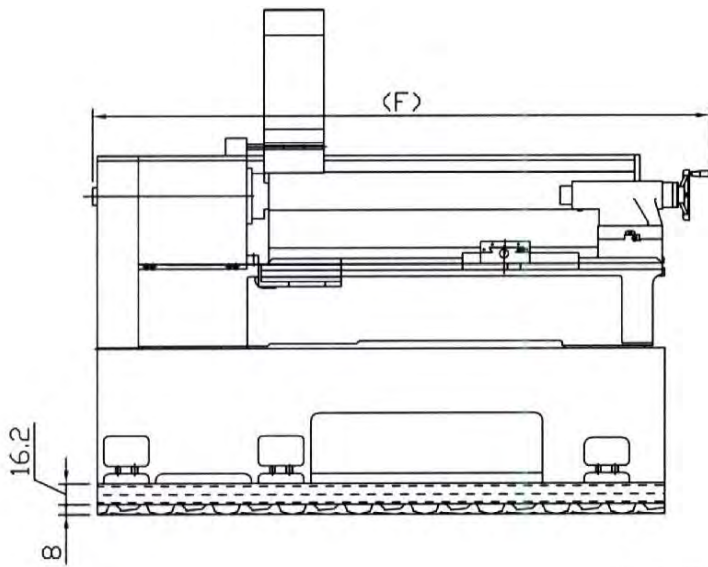

| MODEL     | B       | C    | D    | E    | Dist. Between centers |      |      |      |
|-----------|---------|------|------|------|-----------------------|------|------|------|
|           |         |      |      |      | 40                    | 60   | 80   | 120  |
| 18 SERIES | 2"(56)  | 1267 | 1387 | 1862 | 2385                  | 2885 | 3385 |      |
| 21 SERIES | 3"(85)  | 1305 | 1425 | 1900 | 2390                  | 2890 | 3390 | 4390 |
| 25 SERIES | 3"(85)  | 1350 | 1470 | 1945 | 2390                  | 2890 | 3390 | 4390 |
| 21 SERIES | 4"(105) | 1324 | 1444 | 1919 | 2390                  | 2890 | 3390 | 4390 |
| 25 SERIES | 4"(105) | 1369 | 1489 | 1964 | 2390                  | 2890 | 3390 | 4390 |
| 25 SERIES | 6"(155) | 1435 | 1555 | 2030 | 2400                  | 2900 | 3400 | 4400 |

Unit : mm

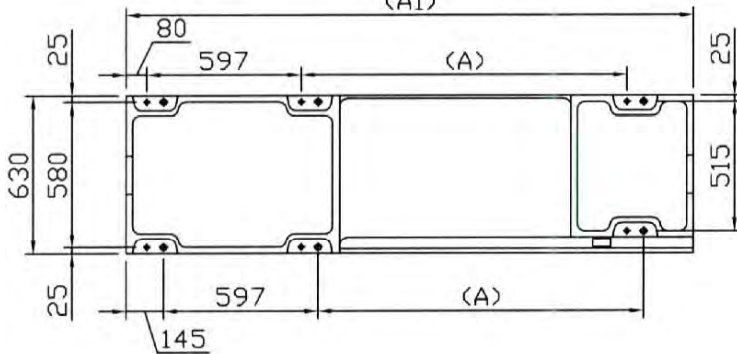

| MODEL          | A    | A1   |
|----------------|------|------|
| 1840/2140/2540 | 1255 | 2190 |
| 1860/2160/2560 | 1755 | 2690 |
| 1880/2180/2580 | 2255 | 3190 |

Unit : mm

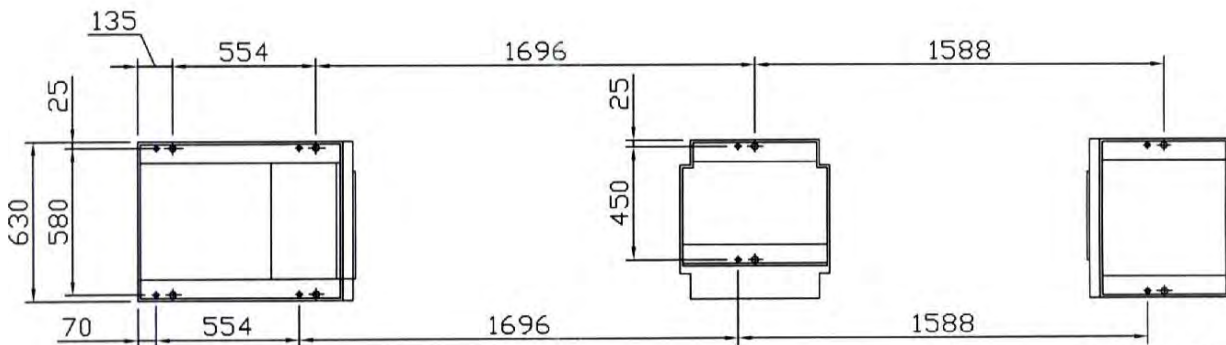

2011.01.25

## **CLEAN UP**

Anti-corrosive material was applied on the machine before transportation. To clean up the bedways, slideways, and lead screws etc., we can use dissolvable solvent to clean off the anti-corrosive material. Do not use lacquer, varnish or kerosene; apply lubricating oil to all the necessary areas. Please check all the handles and levers to see if they are functioning properly. If they are, please set all levers on the neutral position.

## **ELECTRICAL POWER CONNECTION**

Electrical cabinet is provided at the rear top side of the headstock. In the cabinet, there is a separate sub-panel for all of the electrical components, transformers and fuses etc. We also provide the electrical connecting diagrams at the electrical component section.

## **CAUTIONS**

After wiring, please check the spindle rotating direction by turning on the power switch or the jogging switch etc. If the spindle rotates in counterclockwise, it is the correct wiring. If it is not, we can interchange two of the connecting terminals (R.S.T.) to make it right, and we can turn the spindle on to double check the rotating direction again.



# **ELECTRICAL & CIRCUIT DIAGRAM**

**FOR MODEL : E-lathe 18" series**

**E-lathe 21"/25" series**

# E-lathe (SPEED CHANGE: 3 STEPS)

## Electrical Diagram & Its Circuit

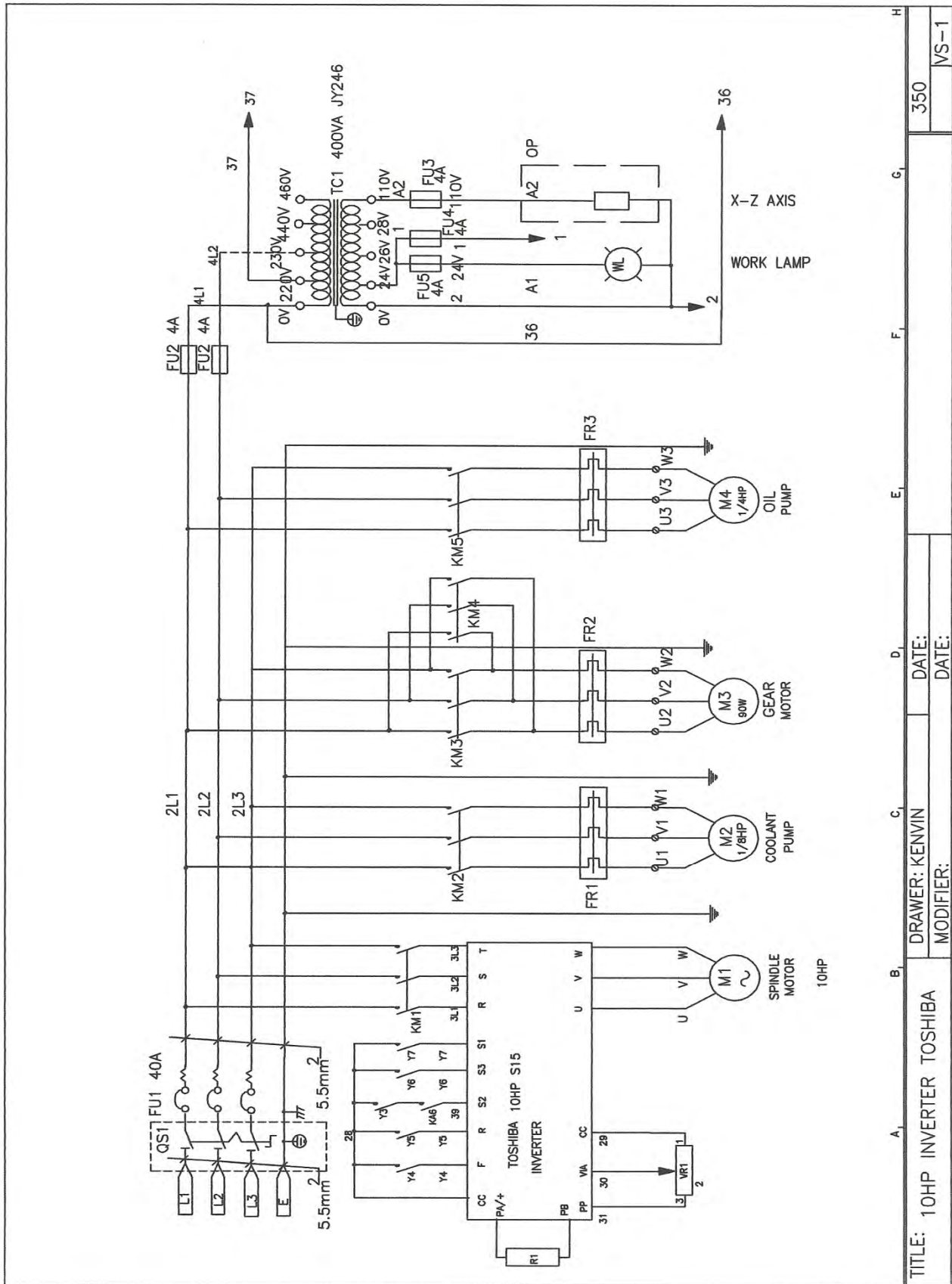

|                              |  |                |  |                |  |                |  |
|------------------------------|--|----------------|--|----------------|--|----------------|--|
| TITLE: 10HP INVERTER TOSHIBA |  | DRAWER: KENVIN |  | DATE:          |  | DATE:          |  |
| A <sub>1</sub>               |  | B <sub>1</sub> |  | C <sub>1</sub> |  | D <sub>1</sub> |  |
| E <sub>1</sub>               |  | F <sub>1</sub> |  | G <sub>1</sub> |  | H <sub>1</sub> |  |
| 350                          |  | VS-1           |  |                |  |                |  |

# Electrical Diagram & Its Circuit

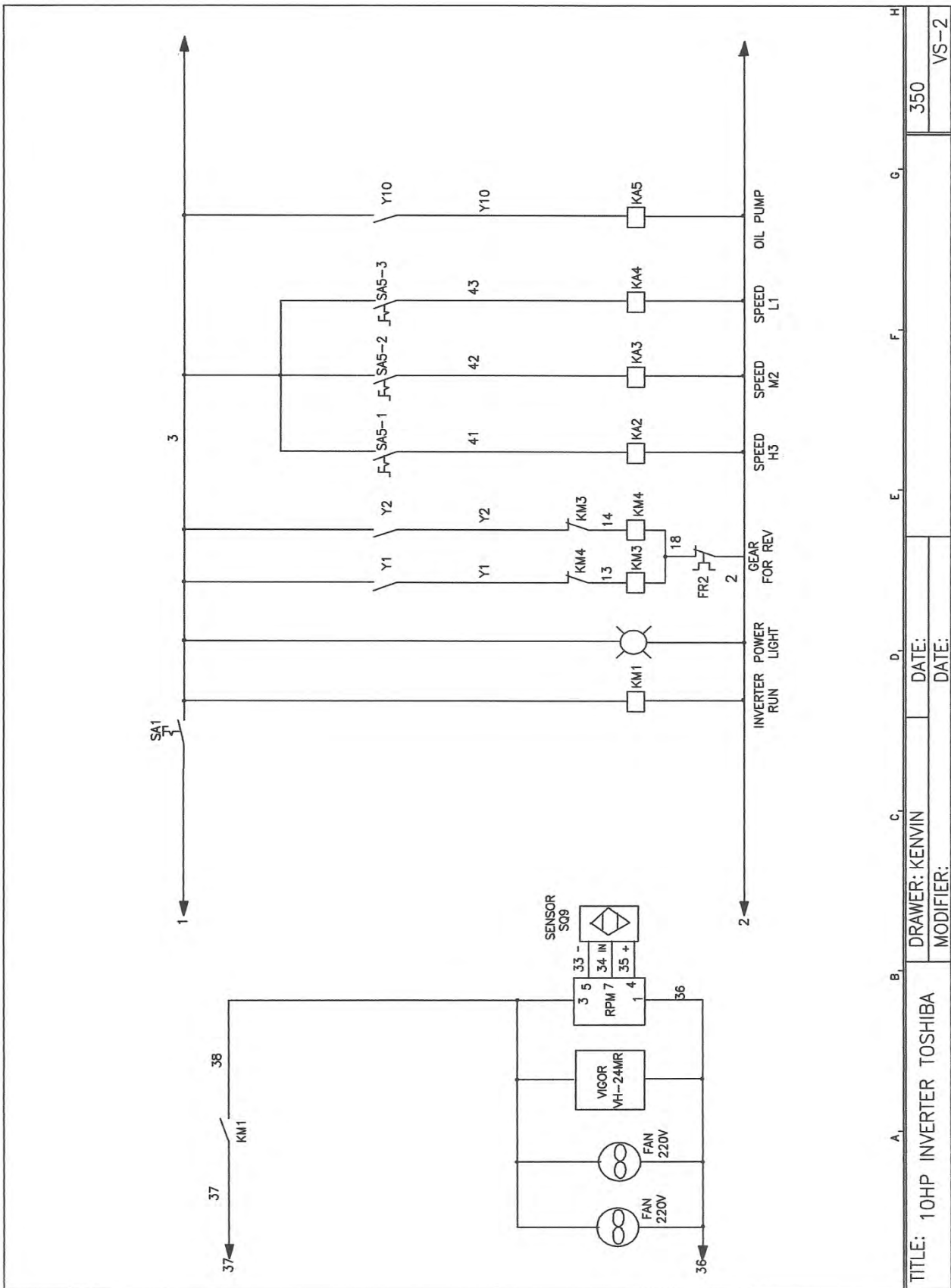

|                              |  |                |  |       |  |     |  |
|------------------------------|--|----------------|--|-------|--|-----|--|
| TITLE: 10HP INVERTER TOSHIBA |  | DRAWER: KENVIN |  | DATE: |  | 350 |  |
| MODIFIER:                    |  | DATE:          |  | VS-2  |  |     |  |



# Electrical Diagram & Its Circuit

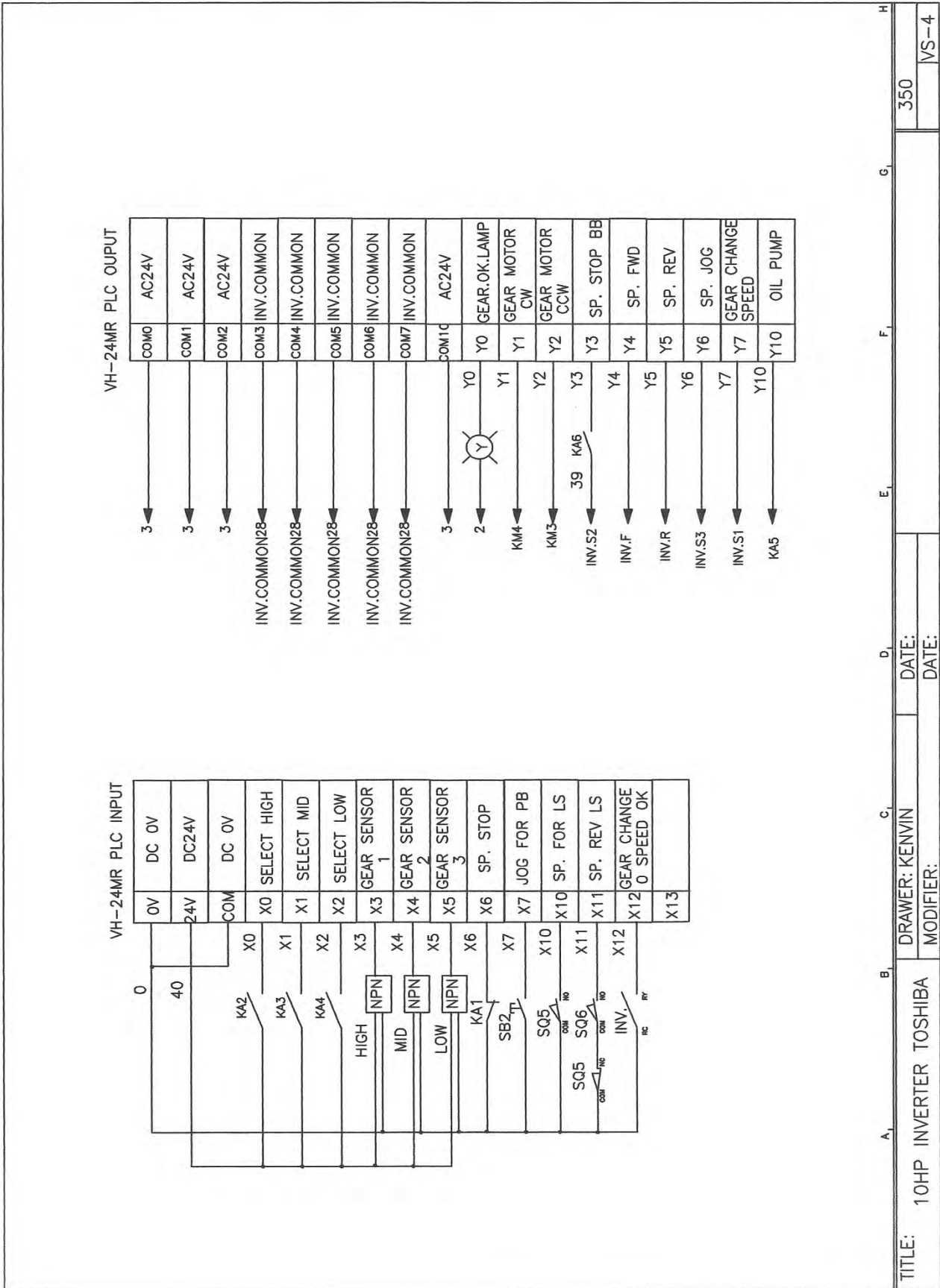

# Control Panel Layout

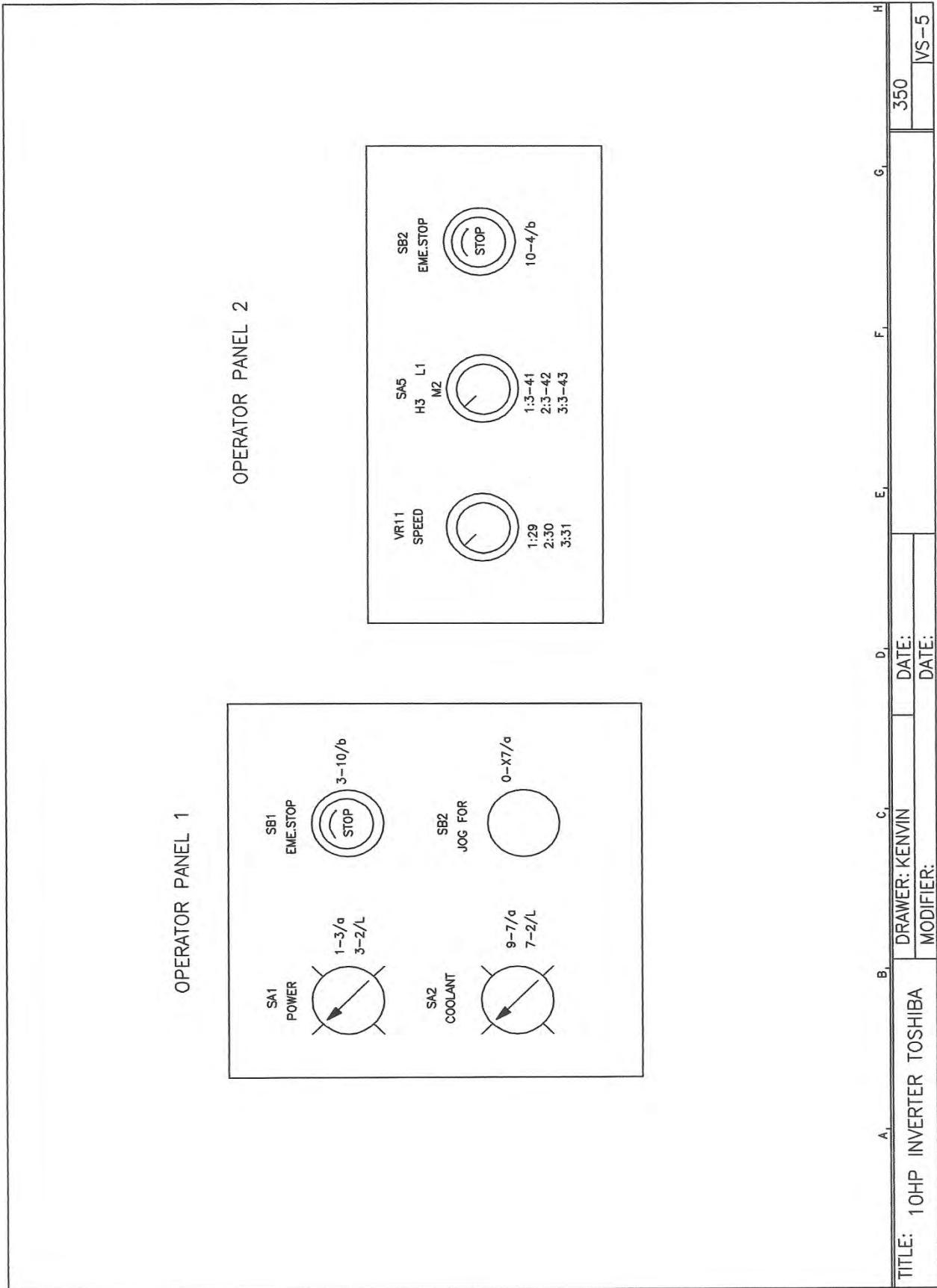



## Electrical Component List

Model 21" series

230V 10HP

INVERTER

| Item | Designation | Description and Function    | Suppliers Reference | Technical data       | Remarks   |
|------|-------------|-----------------------------|---------------------|----------------------|-----------|
| 1    | TC1         | Transformer                 | JY246               | 400VA0V-460V         |           |
| 2    | QS1         | Supply Disconnecting Switch | OT-32E3             | 690V/32A             | CE/UL/CSA |
| 3    | FU1         | NFB No Fuse Breaker         | C-40                | 400V40A              | CE        |
| 4    | FU2         | Fuse Blocks                 | RT18-32X            | 600V32A              | CE        |
| 5    | FU3         | Fuse Blocks                 | RT18-32X            | 600V32A              | CE        |
| 6    | FU4         | Fuse Blocks                 | RT18-32X            | 600V32A              | CE        |
| 7    | FU5         | Fuse Blocks                 | RT18-32X            | 600V32A              | CE        |
| 8    | FU2         | Fuse                        | 10X38               | 4A                   | CE        |
| 9    | FU3         | Fuse                        | 10X38               | 4A                   | CE        |
| 10   | FU4         | Fuse                        | 10X38               | 4A                   | CE        |
| 11   | FU5         | Fuse                        | 10X38               | 4A                   | CE        |
| 12   | KM1         | Power Magnetic Contacttor   | CU32                | Coil AC24V 220V 10HP | CE/UL/CSA |
| 13   | KM2         | Coolant Magnetic Contacttor | CU11                | Coil AC24V 220V 5HP  | CE/UL/CSA |
| 14   | KM3         | Gear Magnetic Contacttor    | CU11                | Coil AC24V 220V 5HP  | CE/UL/CSA |
| 15   | KM4         | Gear Magnetic Contacttor    | CU11                | Coil AC24V 220V 5HP  | CE/UL/CSA |
| 16   | KM5         | Oil Magnetic Contacttor     | CU11                | Coil AC24V 220V 5HP  | CE/UL/CSA |
| 17   | KA1         | Run Relay                   | MY2                 | Coil AC24V           | CE/UL/CSA |
| 18   | KA2         | Speed Hi Relay              | MY2                 | Coil AC24V           | CE/UL/CSA |
| 19   | KA3         | Speed Ma Relay              | MY2                 | Coil AC24V           | CE/UL/CSA |
| 20   | KA4         | Speed Lo Relay              | MY2                 | Coil AC24V           | CE/UL/CSA |
| 21   | KA5         | Oil pump Relay              | MY2                 | Coil AC24V           | CE/UL/CSA |
| 22   | KA6         | Brake Relay                 | MY2                 | Coil AC24V           | CE/UL/CSA |
| 23   | FR1         | Coolant Overload Relay      | RHU10K              | 0.35-0.5A            | CE/UL/CSA |
| 24   | FR2         | Gear Overload Relay         | RHU10K              | 1.1-1.6A             | CE/UL/CSA |
| 25   | FR3         | Oil Overload Relay          | RHU10K              | 1.1-1.6A             | CE/UL/CSA |
| 26   | X1          | Terminal Blocks             | TB50A*6P            | 600V/50A             | CE/UL     |
| 27   | X2          | Terminal Blocks             | TB20A*48P           | 600V/ 20A            | CE/UL     |
| 28   | SA1         | Power Selection Switch      | SL22-1/O            | 120V/6A/1a/24V(G)    | CE/UL/CSA |
| 29   | SA2         | Coolant Selection Switch    | SL22-1/O            | 120V/6A/1a/24V(G)    | CE/UL/CSA |
| 30   | SA3         | Ripid Selection Switch      | SL22-2/O 1-0-2      | 120V/6A/2a(B)        | CE/UL/CSA |
| 31   | SB1         | Emergency Stop              | LEB22-1/C/O         | 120V/6A/1b(R)        | CE/UL/CSA |
| 32   | SB2         | Jogging Push Button Switch  | LBF22-1/O           | 120V/6A/1a(G)        | CE/UL/CSA |
| 33   | SB3         | Emergency Stop              | LEB22-1/C/O         | 120V/6A/1b(R)        | CE/UL/CSA |
| 34   | SQ1         | Hi Gear Sensor              | TS12-02N-1          | 24VDC                | CE        |
| 35   | SQ2         | Ma Gear Sensor              | TS12-02N-1          | 24VDC                | CE        |
| 36   | SQ3         | Lo Gear Sensor              | TS12-02N-1          | 24VDC                | CE        |
| 37   | SQ4         | End Cover Limit Switch      | AM-1701             | 250V/15A             | CE        |
| 38   | SQ5         | For Limit Switch            | AM-1704             | 250V/15A             | CE        |
| 39   | SQ6         | Rev Limit Switch            | AM-1704             | 250V/15A             | CE        |
| 31   | SQ7         | Brake Limit Switch          | AM-1704             | 250V/15A             | CE        |
| 32   | SQ9         | Speed Sensor                | TL-E5NE1            | 24VDC                | CE        |
| 33   | PLC         | Programable Logic Controlle | VH-24MR             | 100-250VAC           | CE        |
| 34   | 10HP        | Inverter                    | VFD055B43A          | 230V7.5KW            | CE /UL    |
| 35   | RPM         | Spindle Rpm                 | RLF-40K             | 110V/220V            |           |
| 36   | M1          | Spindle Motor               | 230V 10HP           | 230V 7.5KW           |           |
| 37   | M2          | Coolant Motor               | 230V 1/8HP          | 230V 0.2KW           |           |
| 38   | M3          | Gear Motor                  | 230V 1/4HP          | 230V 0.093KW         |           |
| 39   | M4          | Oil pump Motor              | 230V 1/4HP          | 230V 0.093KW         |           |
| 40   | EI          | Work Light                  | A-181A              | AC-24V/70W           |           |



# E-lathe (SPEED CHANGE : 3 STEPS) + Z-AXIS RAPID TRAVEL

## Electrical Diagram & Its Circuit

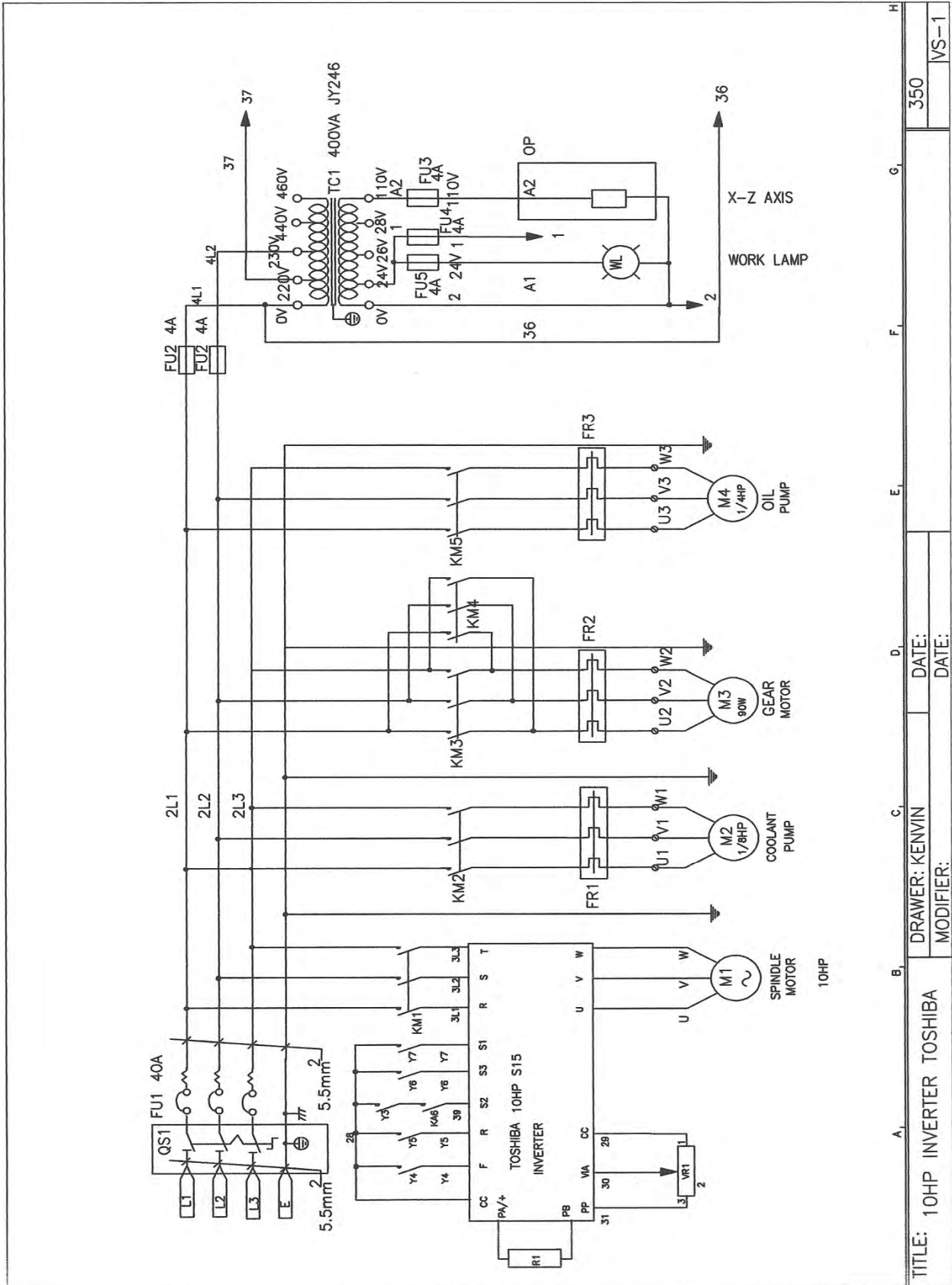

|                              |  |                |  |                |  |                |  |                |  |                |  |
|------------------------------|--|----------------|--|----------------|--|----------------|--|----------------|--|----------------|--|
| TITLE: 10HP INVERTER TOSHIBA |  | DRAWER: KENVIN |  | DATE:          |  | DATE:          |  | 350            |  | VS-1           |  |
| A <sub>1</sub>               |  | B <sub>1</sub> |  | C <sub>1</sub> |  | D <sub>1</sub> |  | E <sub>1</sub> |  | G <sub>1</sub> |  |

# Electrical Diagram & Its Circuit

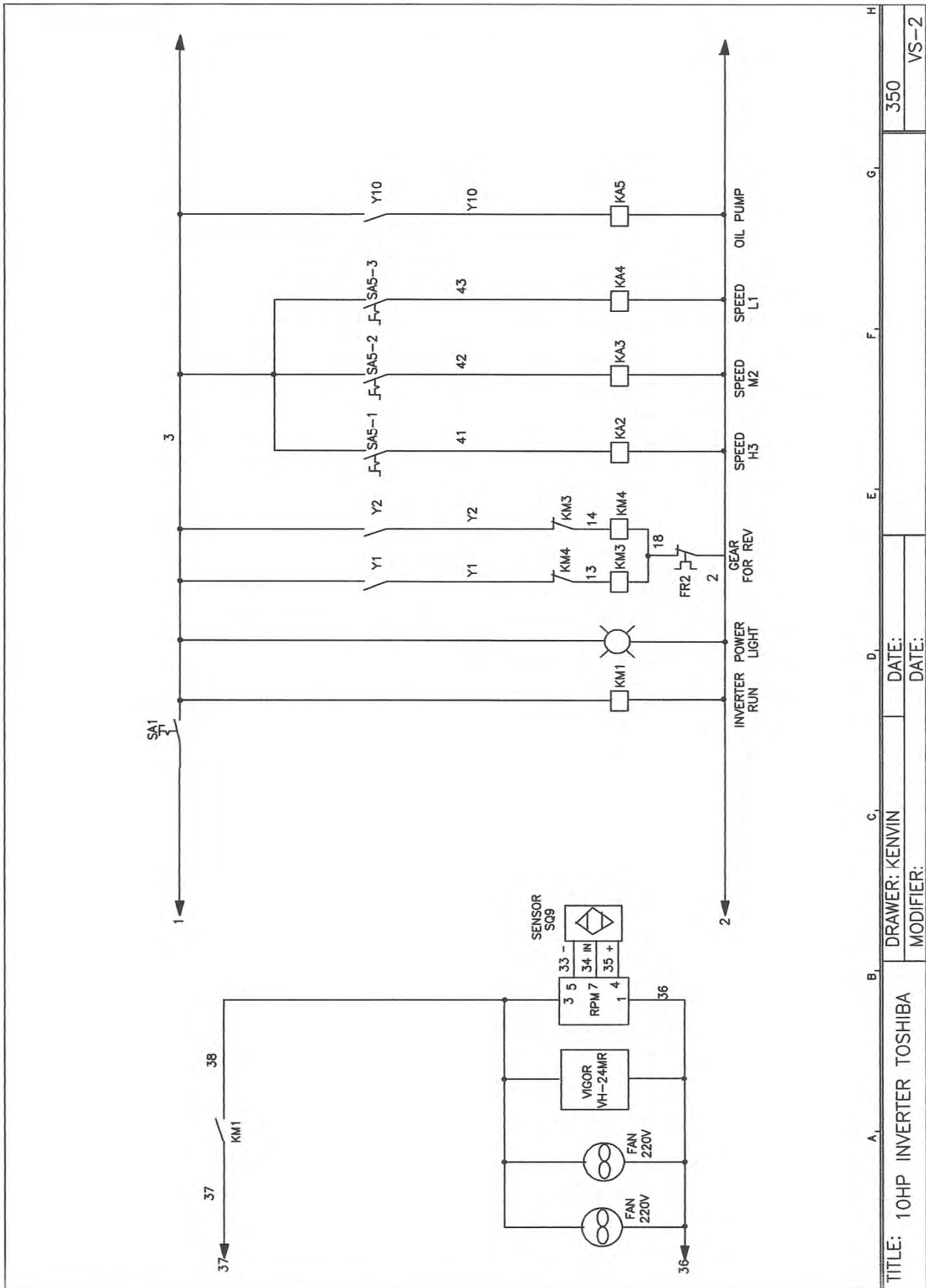

|                              |                |                |                |                |                |                |                |
|------------------------------|----------------|----------------|----------------|----------------|----------------|----------------|----------------|
| A <sub>1</sub>               | B <sub>1</sub> | C <sub>1</sub> | D <sub>1</sub> | E <sub>1</sub> | F <sub>1</sub> | G <sub>1</sub> | H <sub>1</sub> |
| TITLE: 10HP INVERTER TOSHIBA |                |                |                |                |                |                | 350            |
| DRAWER: KENVIN               |                |                |                |                |                |                | VS-2           |
| MODIFIER:                    |                |                |                |                |                |                |                |
| DATE:                        |                |                |                |                |                |                |                |
| DATE:                        |                |                |                |                |                |                |                |



# Electrical Diagram & Its Circuit

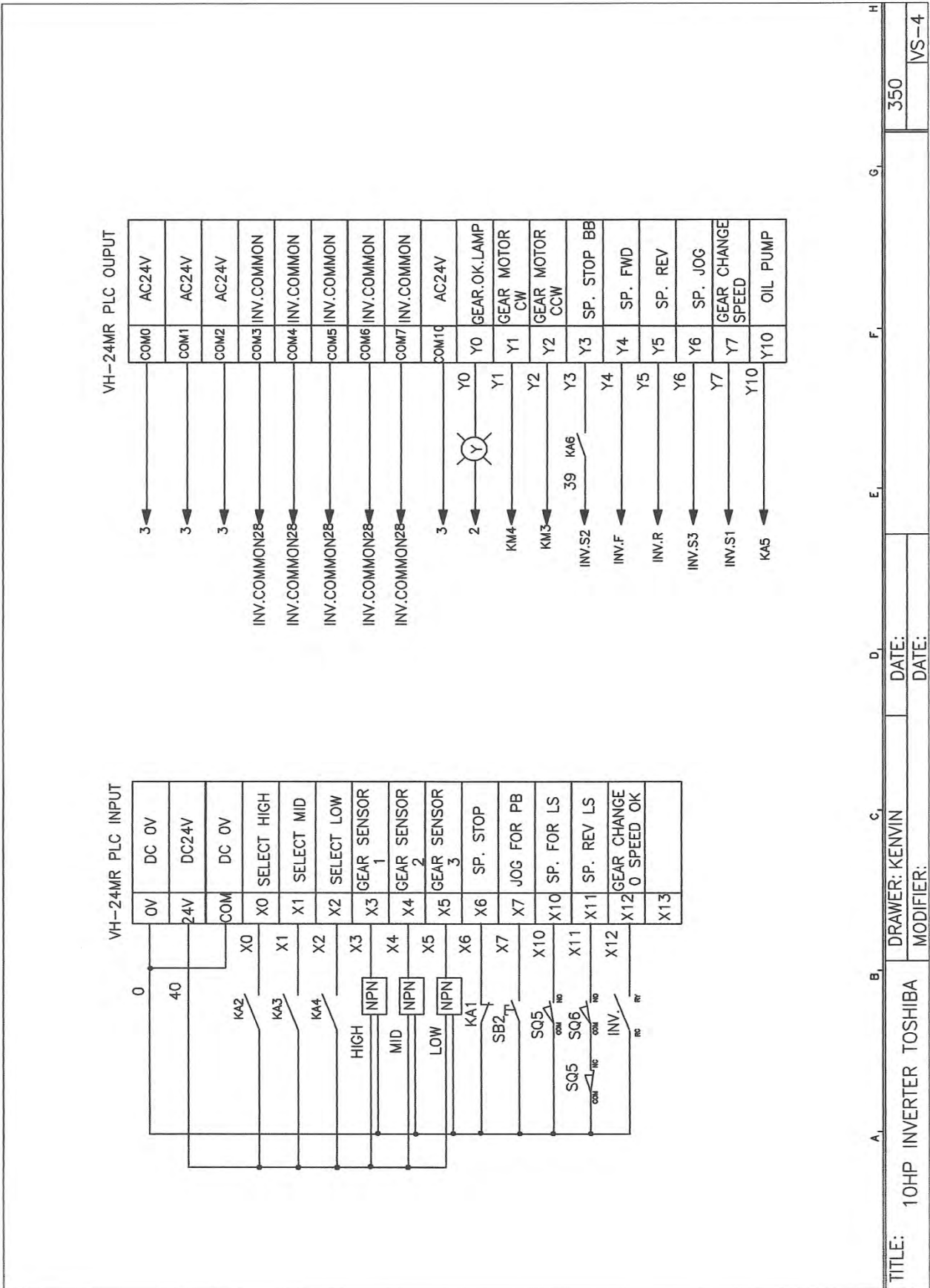

# Electrical Diagram & Its Circuit

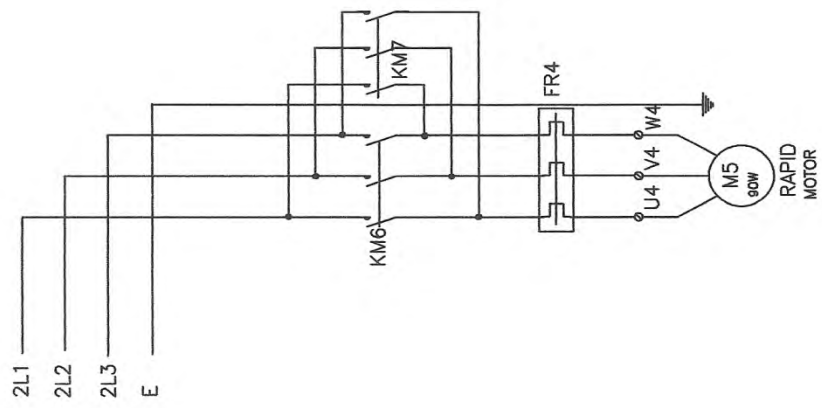

|                              |    |                |    |       |    |       |    |
|------------------------------|----|----------------|----|-------|----|-------|----|
| A.                           | B. | C.             | D. | E.    | F. | G.    | H. |
| TITLE: 10HP INVERTER TOSHIBA |    | DRAWER: KENVIN |    | DATE: |    | DATE: |    |
| MODIFIER:                    |    |                |    |       |    | 350   |    |
|                              |    |                |    |       |    | VS-6  |    |

# Control Panel Layout

OPERATOR PANEL 1

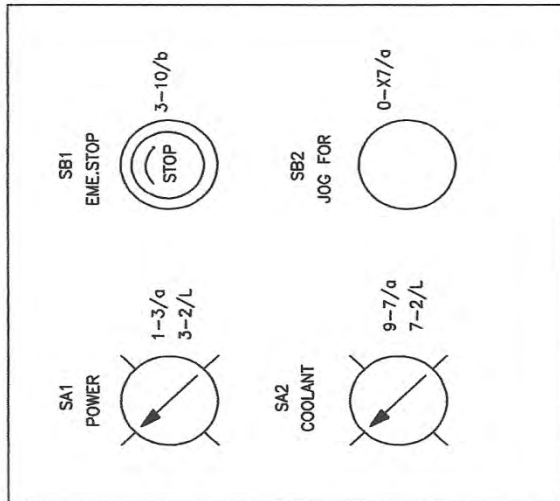

OPERATOR PANEL 2

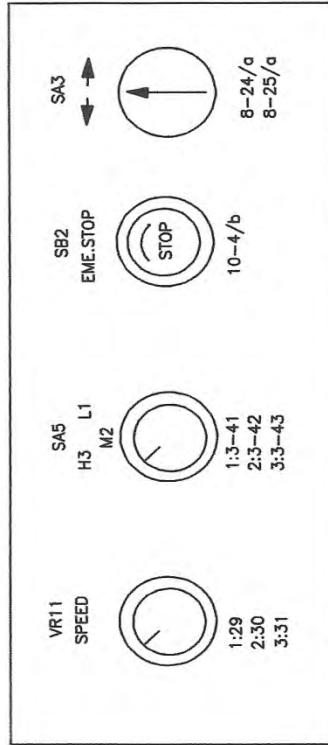

|                              |    |                |    |       |    |      |    |
|------------------------------|----|----------------|----|-------|----|------|----|
| A.                           | B. | C.             | D. | E.    | F. | G.   | H. |
| TITLE: 10HP INVERTER TOSHIBA |    | DRAWER: KENVIN |    | DATE: |    | 350  |    |
| MODIFIER:                    |    | DATE:          |    |       |    | VS-5 |    |



## Electrical Component List

|      |       | Model 21", 25" SERIES 230V 10HP INVERTER |                 |                         |           |
|------|-------|--|-----------------|-------------------------|-----------|
|      |       | <u>Z AXIS WITH RIPID TRAVEL</u>          |                 |                         |           |
| Item | Part# | Description and Function                 | Suppliers item# | Technical data          | Remarks   |
| 1    | TC1   | Transformer                              | JY246           | 400VA0V-460V            |           |
| 2    | QS1   | Supply Disconnecting Switch              | OT-32E3         | 690V/32A                | CE/UL/CSA |
| 3    | FU1   | NFB No Fuse Breaker                      | C-40            | 400V40A                 | CE        |
| 4    | FU2   | Fuse Blocks                              | RT18-32X        | 600V32A                 | CE        |
| 5    | FU3   | Fuse Blocks                              | RT18-32X        | 600V32A                 | CE        |
| 6    | FU4   | Fuse Blocks                              | RT18-32X        | 600V32A                 | CE        |
| 7    | FU5   | Fuse Blocks                              | RT18-32X        | 600V32A                 | CE        |
| 8    | FU2   | Fuse                                     | 10X38           | 4A                      | CE        |
| 9    | FU3   | Fuse                                     | 10X38           | 4A                      | CE        |
| 10   | FU4   | Fuse                                     | 10X38           | 4A                      | CE        |
| 11   | FU5   | Fuse                                     | 10X38           | 4A                      | CE        |
| 12   | KM1   | Power Magnetic Contactor                 | CU32            | Coil AC24V 220V<br>10HP | CE/UL/CSA |
| 13   | KM2   | Coolant Magnetic Contactor               | CU11            | Coil AC24V 220V<br>5HP  | CE/UL/CSA |
| 14   | KM3   | Gear Magnetic Contactor                  | CU11            | Coil AC24V 220V<br>5HP  | CE/UL/CSA |
| 15   | KM4   | Gear Magnetic Contactor                  | CU11            | Coil AC24V 220V<br>5HP  | CE/UL/CSA |
| 16   | KM5   | Oil Magnetic Contactor                   | CU11            | Coil AC24V 220V<br>5HP  | CE/UL/CSA |
| 17   | KM6   | Rapid Magnetic Contactor                 | CU11            | Coil AC24V 220V<br>5HP  | CE/UL/CSA |
| 18   | KM7   | Rapid Magnetic Contactor                 | CU11            | Coil AC24V 220V<br>5HP  | CE/UL/CSA |
| 19   | KA1   | Run Relay                                | MY2             | Coil AC24V              | CE/UL/CSA |
| 20   | KA2   | Speed Hi Relay                           | MY2             | Coil AC24V              | CE/UL/CSA |
| 21   | KA3   | Speed Mid Relay                          | MY2             | Coil AC24V              | CE/UL/CSA |
| 22   | KA4   | Speed Low Relay                          | MY2             | Coil AC24V              | CE/UL/CSA |
| 23   | KA5   | Oil Pump Relay                           | MY2             | Coil AC24V              | CE/UL/CSA |
| 24   | KA6   | Brake Relay                              | MY2             | Coil AC24V              | CE/UL/CSA |



|    |      |                                  |                   |                   |           |
|----|------|----------------------------------|-------------------|-------------------|-----------|
| 25 | FR1  | Coolant Overload Relay           | RHU10K            | 0.35-0.5A         | CE/UL/CSA |
| 26 | FR2  | Gear Overload Relay              | RHU10K            | 1.1-1.6A          | CE/UL/CSA |
| 27 | FR3  | Oil Overload Relay               | RHU10K            | 1.6-2.5A          | CE/UL/CSA |
| 28 | FR4  | Rapid Overload Relay             | RHU10K            | 1.6-2.5A          | CE/UL/CSA |
| 29 | X1   | Terminal Blocks                  | TB50A*6P          | 600V/50A          | CE/UL     |
| 30 | X2   | Terminal Blocks                  | TB20A*48P         | 600V/ 20A         | CE/UL     |
| 31 | SA1  | Power Selection Switch           | SL22-1/O          | 120V/6A/1a/24V(G) | CE/UL/CSA |
| 32 | SA2  | Coolant Selection Switch         | SL22-1/O          | 120V/6A/1a/24V(G) | CE/UL/CSA |
| 33 | SA3  | Rapid Selection Switch           | SL22-2/O<br>1-0-2 | 120V/6A/2a(B)     | CE/UL/CSA |
| 34 | SB1  | Emergency Stop                   | LEB22-1/C/O       | 120V/6A/1b(R)     | CE/UL/CSA |
| 35 | SB2  | Jogging Push Button Switch       | LBF22-1/O         | 120V/6A/1a(G)     | CE/UL/CSA |
| 36 | SB3  | Emergency Stop                   | LEB22-1/C/O       | 120V/6A/1b(R)     | CE/UL/CSA |
| 37 | SQ1  | Hi Gear Sensor                   | TS12-02N-1        | 24VDC             | CE        |
| 38 | SQ2  | Mid Gear Sensor                  | TS12-02N-1        | 24VDC             | CE        |
| 39 | SQ3  | Low Gear Sensor                  | TS12-02N-1        | 24VDC             | CE        |
| 31 | SQ4  | End Cover Limit Switch           | AM-1701           | 250V/15A          | CE        |
| 32 | SQ5  | Forward Limit Switch             | AM-1704           | 250V/15A          | CE        |
| 33 | SQ6  | Reverse Limit Switch             | AM-1704           | 250V/15A          | CE        |
| 34 | SQ7  | Brake Limit Switch               | AM-1704           | 250V/15A          | CE        |
| 35 | SQ9  | Speed Sensor                     | TL-E5NE1          | 24VDC             | CE        |
| 36 | PLC  | Programmable Logic<br>Controller | VH-24MR           | 100-250VAC        | CE        |
| 37 | 10HP | Inverter                         | VFD055B43A        | 230V7.5KW         | CE /UL    |
| 38 | RPM  | Spindle RPM                      | RLF-40K           | 110V/220V         |           |
| 39 | M1   | Spindle Motor                    | 230V 10HP         | 230V 7.5KW        |           |
| 40 | M2   | Coolant Motor                    | 230V 1/8HP        | 230V 0.093KW      |           |
| 41 | M3   | Gear Motor                       | 230V 1/4HP        | 230V 0.2KW        |           |
| 42 | M4   | Oil pump Motor                   | 230V 1/4HP        | 230V 0.2KW        |           |
| 43 | E1   | Work Light                       | A-181A            | AC-24V/70W        |           |

# **ELECTRICAL CIRCUIT DIAGRAM FOR CE REQUIREMENT**

**FOR MODEL : E-lathe 18'' series**

**E-lathe 21''/25'' series**

CE\_Inverter Type Lathe (SPEED CHANGE: 3 STEP)  
Control Panel Layout

OPERATOR PANEL 1 OPERATOR PANEL 2

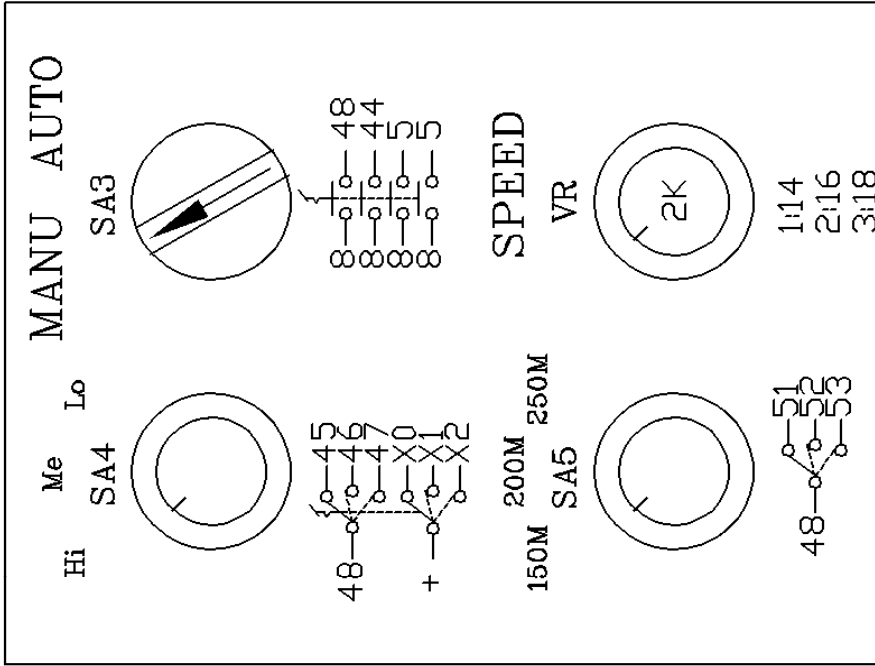
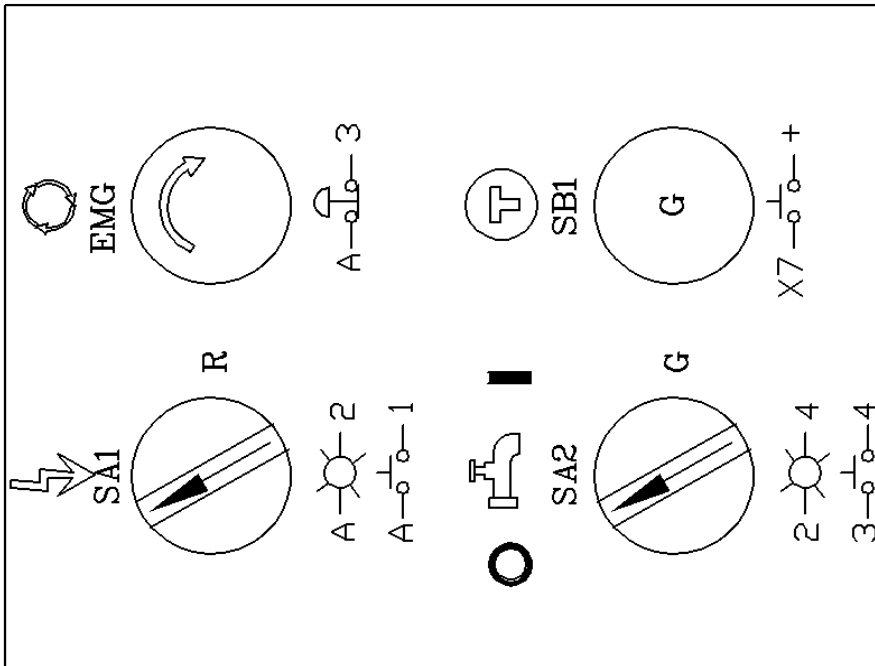

|                              |              |
|------------------------------|--------------|
| 賦津企業有限公司                     |              |
| TYPE                         | PLC+INVERTER |
| TITLE OPERATOR PANEL DIAGRAM |              |
| DATE                         | REV.         |
| DESIGNER                     | CHK.         |
| APPROVED                     | DATE         |
| FIG. NO.                     | REV.         |
| 01                           | 1            |



Electrical Diagram & Its Circuit

2008/11/25

PLC+INVERTER+FAST 7.5HP(10.15,20,25)HP

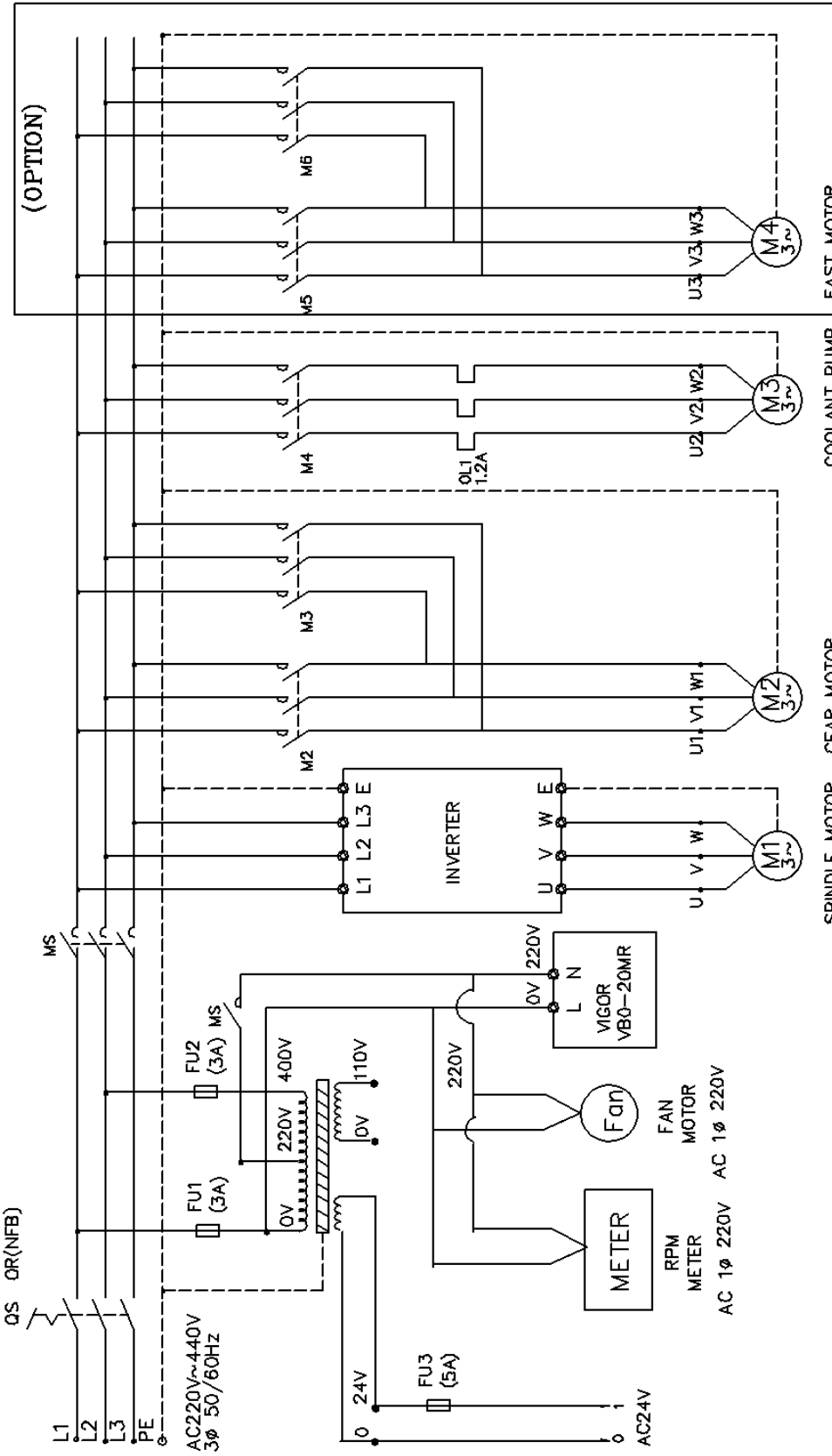

賦津企業有限公司

|             |                    |
|-------------|--------------------|
| FIG. NO.    | PLC+INVERTER       |
| TITLE       | MAIN POWER DIAGRAM |
| DESIGNED BY |                    |
| DATE        |                    |
| DRW. NO.    | 08                 |
| REV.        | 1                  |



# Electrical Diagram & Its Circuit

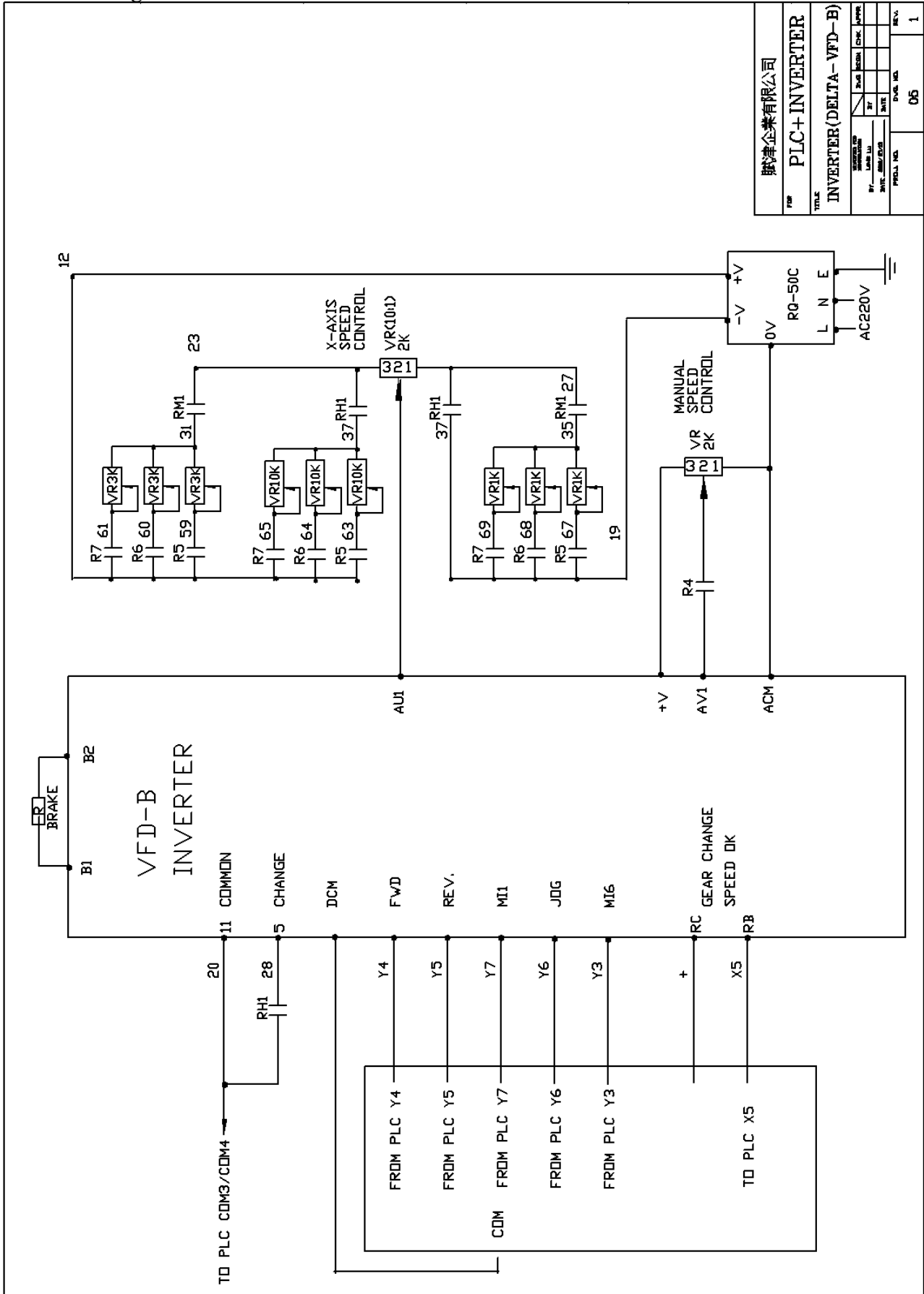

|                                       |                    |                  |           |
|---------------------------------------|--------------------|------------------|-----------|
| 威達企業有限公司<br><b>FOR PIC+INVERTER</b>   |                    |                  |           |
| TITLE<br><b>INVERTER(DELTA-VFD-B)</b> |                    |                  |           |
| DRAWN BY<br>DATE                      | CHECKED BY<br>DATE | P. NO. NO.<br>05 | REV.<br>1 |

# Electrical Diagram & Its Circuit

PLC-VH-32MR(NPN)2010-08-23

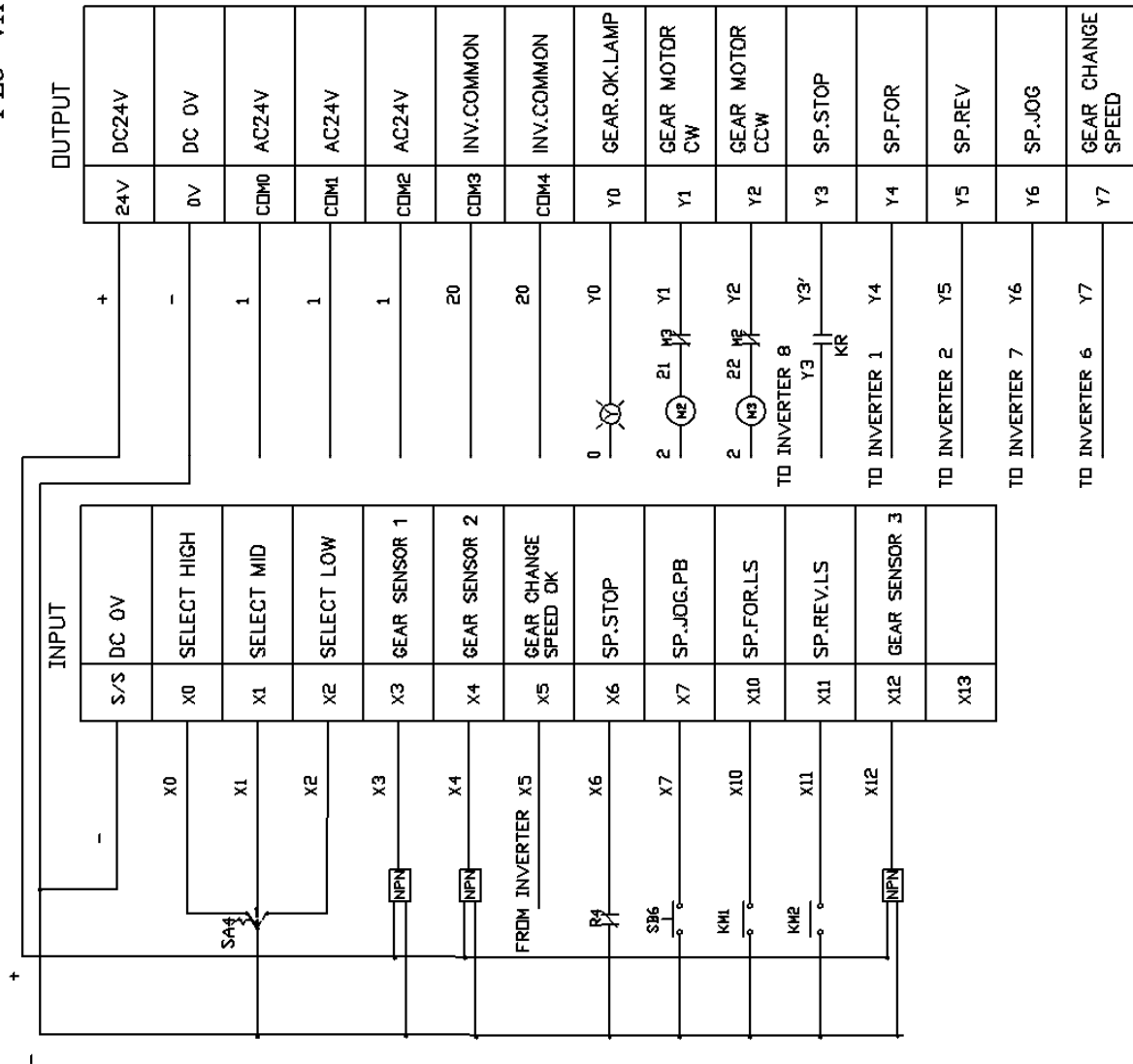

|              |       |
|--------------|-------|
| 賦津企業有限公司     |       |
| PLC+INVERTER |       |
| PLC DIAGRAM  |       |
| DATE         | REV.  |
| BY           | DATE  |
| PROJECT NO.  | SCALE |
|              | 06 1  |



# Electrical Component List

| Manufacturer Order |                               | SCHEDULE OF ELECTRICAL EQUIPMENT          |          |               |                    | Manufacturer Order |                              | SCHEDULE OF ELECTRICAL EQUIPMENT   |          |               |                    |
|--------------------|-------------------------------|---|----------|---------------|--------------------|--------------------|------------------------------|--|----------|---------------|--------------------|
|                    |                               | TYPE LATHE MACHINE: INV+PLC               |          | See also list |                    |                    |                              | TYPE LATHE MACHINE: INV+PLC  |          | See also list |                    |
| Item               | Description and function      | Technical data                            | Quantity | Supplier      | Supplier reference | Item               | Description and function     | Technical data   | Quantity | Supplier      | Supplier reference |
| QS                 | Main Power(Door lock) Switch  | AC 600V/50HZ<br>3P 25A                    | 1        | MACK          | MK-325             | QS                 | Main Power(Door lock) Switch | AC 600V/50HZ<br>3P 25A   | 1        | MACK          | MK-325             |
| FU1                | AC FUSE                       | AC 600V                                   | 1        | SHINGO        | FS-011             | LS4                | Safe-Cover                   | AC 125V 10A<br>250V 10A MAX.600V   | 1        | MOQUIEN       | MJ-1701            |
| FU2                | TO TRANSFORMER                | 30MM 5A                                   | 1        | SHINGO        | FS-011             | LS2                | For-Limit-Switch             | AC 125V 10A<br>250V 10A MAX.600V   | 1        | MOQUIEN       | MJ-1704            |
| FU3                | AC Low Voltage to Transformer | AC 600V<br>30MM 5A                        | 1        | SHINGO        | FS-011             | LS3                | Rev-Limit-Switch             | AC 125V 10A<br>250V 10A MAX.600V   | 1        | MOQUIEN       | MJ-1704            |
| KM2                | Contactors                    | 3P1a R1=AC600V<br>R1=25A                  | 1        | N.H.D         | C-08001            | LS1                | Foot-Out (L-ø)               |  | 1        | AVG           | M-18               |
| KM3                |                               | AC3 220V 2.2KW                            | 1        | N.H.D         | C-08001            | CABLE-LOCK         | Cable-Glands                 |  | 1        | AVG           | M-18               |
| KM4                |                               | 380V 4.0KW                                | 1        | N.H.D         | C-08010            | LINE               | Central-Line                 | 0.75mm <sup>2</sup> MAX.300V<br>(30/0.18)-7A<br>Ambient Temp<br>(35 °C~80 °C)                                | 1        | TOING-WU      |                    |
| FR (O.L)           | Over-Load (Relays)            | UI=AC 600V<br>1th=10A<br>0.9~1.5A<br>1.2A | 1        | N.H.D         | BTH-12             | CABLE              | PVC Cable-Wire               | 2.0mm <sup>2</sup> 40/0.2018a<br>1.25mm <sup>2</sup> 44/0.1611a<br>Ambient Temp<br>(35 °C~80 °C)<br>MAX 600V | 1        | TOING-WU      |                    |
| CRH1               |                               |   | 1        | IDEC-IZUMI    | RY4S-U             | PF-3               | Power-Fuse                   | AC 800V 50A  | 3        | SHININGO      |                    |
| CRM1               | contactors-Relay              | Cell=AC 24V<br>AC 240V 5A<br>DC 30V 5A    | 1        | IDEC-IZUMI    | RY4S-U             | VR                 | INVERTER Selector            | 3K<br>1K   | 6<br>3   |               |                    |
| R5                 |                               |   | 1        | IDEC-IZUMI    | RY4S-U             | VR                 | SPEED Selector               | 2K   | 1        |               |                    |
| R6                 |                               |   | 1        | IDEC-IZUMI    | RY4S-U             | SA4                | HI-LOW Selector              |  | 1        |               |                    |
| R7                 |                               |   | 1        | IDEC-IZUMI    | RY4S-U             | SA5                | MANU Speed Selector          |  | 1        |               |                    |
| CRT                |                               |   | 1        | IDEC-IZUMI    | RY4S-U             | R.P.M              | MAIN-SPEED                   | AC 220/110V  | 1        | CONCH         | RF-40A             |
| CRH2               | contactors-Relay              | Cell=AC 24V<br>AC 240V 5A<br>DC 30V 5A    | 1        | IDEC-IZUMI    | RY4S-U             | SENSOR             | Speed-Sensor                 | DC10V~30V<br>150mA   | 1        | CONCH         | QL-1833A           |
| CRL                |                               |   | 1        | IDEC-IZUMI    | RY4S-U             | SENSOR             | Geur-Sensor                  | DC10V~30V<br>150mA   | 1        | FOTEK         | FM12-02P           |
| R4                 |                               |   | 1        | IDEC-IZUMI    | RY4S-U             | PLC                | Geur-Control                 | AC100V~AC240V  | 1        | LIYAN         | LYPLC EX24HR       |
| TR                 | Transformer                   | AG HI=380V(220V)<br>LB=24V                |          | SUEN-LIANG    | 3P-TBS             |                    |                              |  |          |               |                    |
| TB                 | Casert Terminal-Block         | AC 600V MAX.20A<br>AC 600V MAX.10A        | 3<br>16  | SHINGO        | TS-036<br>TS-016   |                    |                              |  |          |               |                    |
| SA1                | Power Selector Switch         | AC 250V 10A<br>MAX.600V                   | 1        | MACK          | MK/PNC-30ø         |                    |                              |  |          |               |                    |
| SA2                | Pump-Selector                 | AC 250V 10A<br>MAX.600V                   | 1        | MACK          | MK/PNC-30ø         |                    |                              |  |          |               |                    |
| SB1                | Jogging-Botton                | AC 250V 10A<br>MAX.600V                   | 1        | MACK          | MK/ABF-30ø         |                    |                              |  |          |               |                    |
| EMG                | Emergency-Stop                | AC 250V 10A<br>MAX.600V                   | 1        | MACK          | MK/FE-30ø          |                    |                              |  |          |               |                    |
| SA3                | MANU-AUTO Selector Switch     | AC 250V 10A<br>MAX.600V                   | 1        | MACK          | MK/AC-22ø          |                    |                              |  |          |               |                    |

# OPERATION

# HEAVY DUTY PRECISION LATHE (WITH INVERTER)

## Inverter Series Description of Machine

### Components

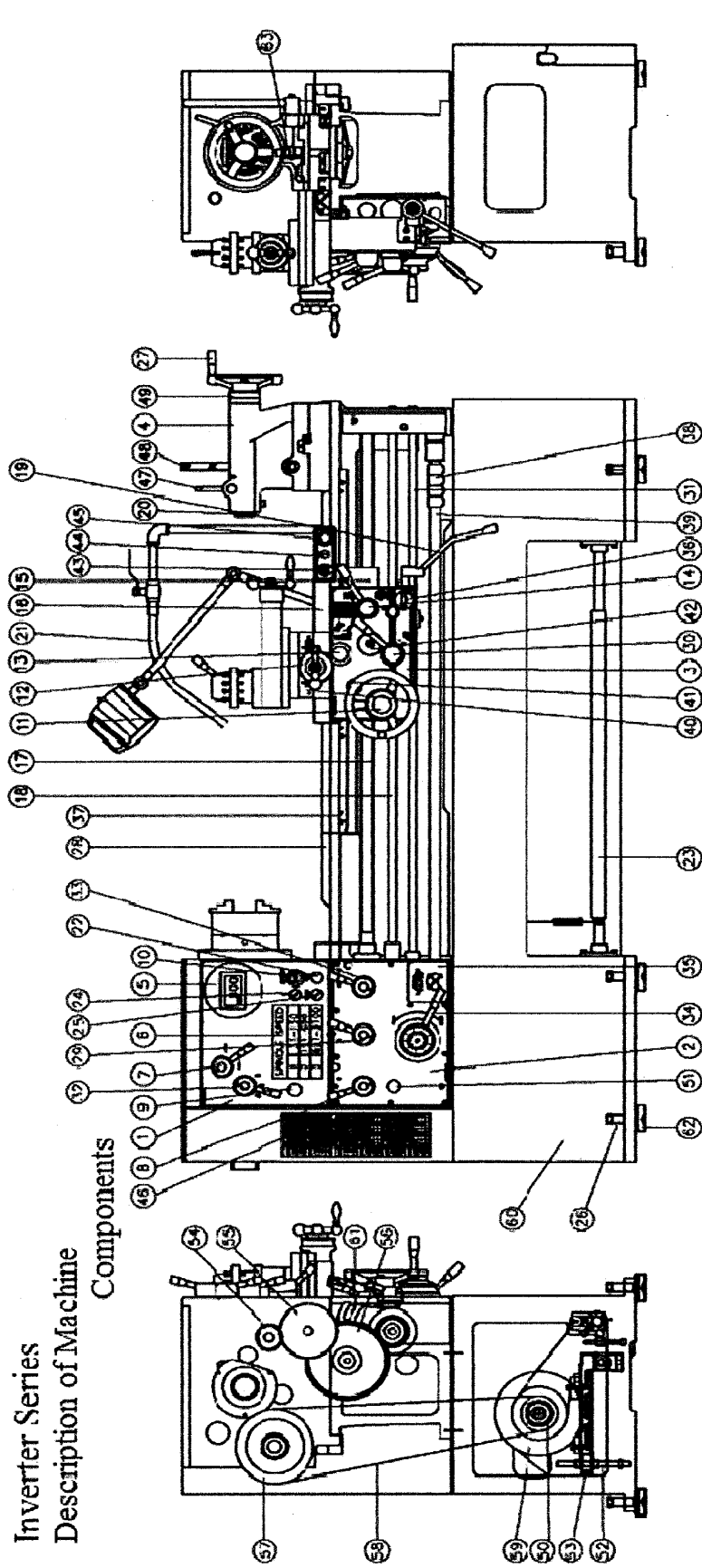

- |                            |  |                               |                                   |                                   |                            |                           |
|----------------------------|--|-------------------------------|-----------------------------------|-----------------------------------|----------------------------|---------------------------|
| 1. Headstock               | 11. Longitudinal handwheel             | 21. Coolant nozzle            | 31. Spindle lever location rod    | 41. Apron oil gauge               | 51. Gear box gauge         | 61. Bracket               |
| 2. Gear box                | 12. Crossfeed handwheel                | 22. Jog button                | 32. Spindle speed selection lever | 42. Anti-slip mechanism           | 52. Adjustment screw       | 62. Leveling pads         |
| 3. Apron                   | 13. Long/Cross feeding selection lever | 23. Brake pedal               | 33. Feed selection lever          | 43. Speed turning knob            | 53. Motor posi. plate      | 63. Tailstock locking nut |
| 4. Tailstock               | 14. Half-nut engagement lever          | 24. Power on/off switch       | 34. Feed selection dial/lever     | 44. Speed selection switch        | 54. Idle (end) gear        |                           |
| 5. RPM meter               | 15. Thread chasing dial                | 25. Coolant on/off switch     | 35. Micro-limit switch            | 45. Emergency switch              | 55. Idle (end) gear large  |                           |
| 6. RPM speed chart         | 16. Saddle                             | 26. Leveling screw            | 36. Apron lube pump handle        | 46. Feed selection chart          | 56. Double-stack idle gear |                           |
| 7. Feed directional lever  | 17. Feed screw                         | 27. Tailstock quill handwheel | 37. Gear racks                    | 47. Quill locking lever           | 57. Spindle pulley         |                           |
| 8. Feed selection lever    | 18. Leadscrew for threading            | 28. Gap                       | 38. Multi-position stop collar    | 48. Tailstock posi. locking lever | 58. V belts                |                           |
| 9. Oil gauge for headstock | 19. Spindle rotation selection lever   | 29. Feed selection lever      | 39. Multi-position stop rod       | 49. Tailstock dial                | 59. Spindle motor          |                           |
| 10. Emergency switch       | 20. Quill for tailstock                | 30. Feed engagement lever     | 40. Cross-slide                   | 50. Motor pulley                  | 60. Machine base           |                           |

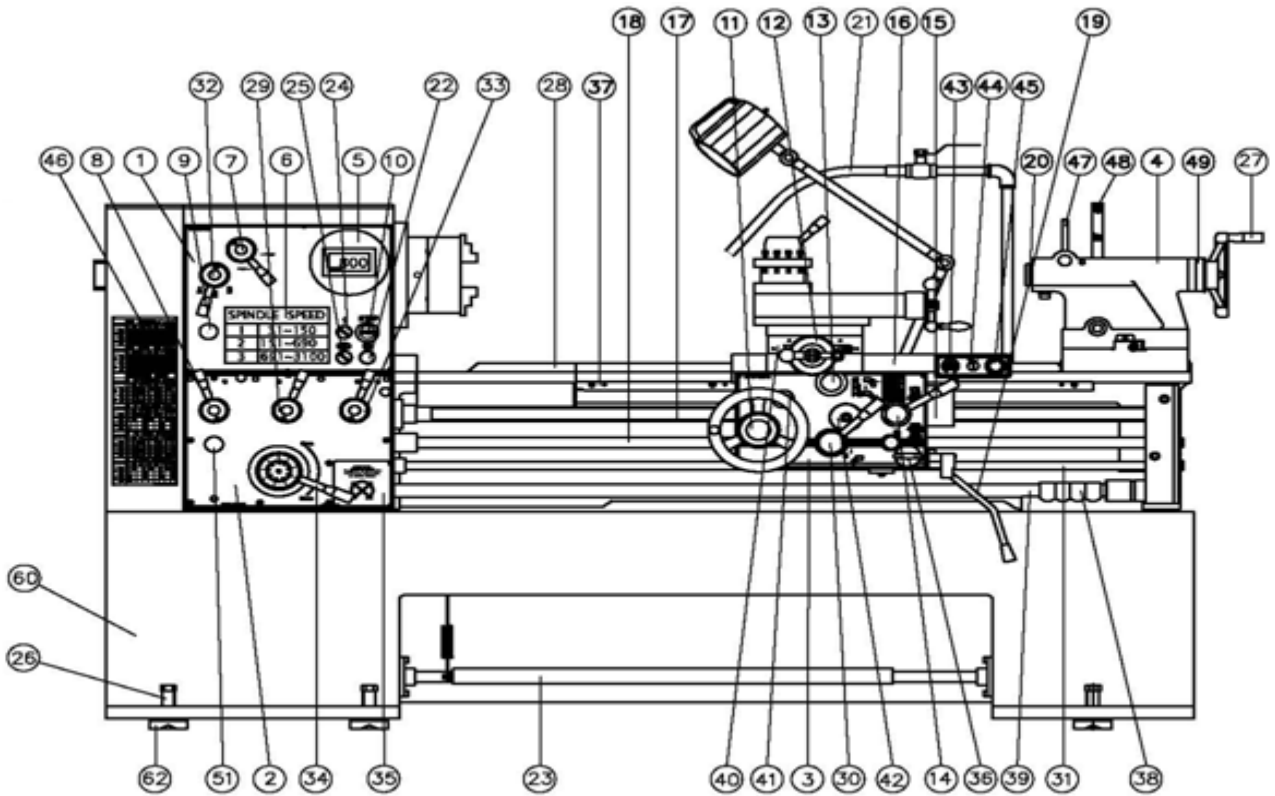

### **SPINDLE SPEED SELECTION, STOP & RE-START (WITH INVERTER)**

The inverter lathe has three speed ranges--high, medium and low.

To operate the lathe, first please turn on the power switch (24) and consider the cutting tool & work piece etc., characters, then move spindle speed selection lever (32) to the desired spindle speed to high, medium or low speed, after that, please move the spindle control lever (19) upward or downward to rotate the spindle in counter-clockwise or in clockwise direction. (Speed ranges are on Chart #2) and the spindle speed is indicated on spindle RPM meter (5) as to adjust spindle speed worker must turn the speed turning knob (43).

If worker wants to stop the spindle rotation, please step on the brake pedal (23) to stop the spindle. After spindle is stopped by pressing brake pedal in order to re-start the spindle rotation, worker must move the spindle control lever (19) again.

This machine uses an inverter to control the spindle speed. To go to the desired spindle speed and turn a work piece, worker shifts speed selection lever (32) to move spindle onto the correct speed range in high, medium or low speed. And then worker must crank the longitudinal traverse handwheel (11) and cross feed handwheel (12) to desired position separately, and finally fine tune the spindle speed with the speed turning knob (43). Next push in the long/cross feeding selection lever to engage in auto longitudinal feeding mechanism, and lastly worker must engage the feed

engagement lever (30) to activate auto longitudinal cutting.

### CAUTIONS

- If worker wants to change the spindle speed, he must stop the spindle rotation. Otherwise, the gears of headstock will be damaged.
- If it is hard to set the spindle speed selection lever (32) on position when making speed changes, worker can push the jogging button (22) slightly and then trying to set the selection lever again.

### HOW TO OPERATE THE JOGGING SWITCH

During operation, if worker wants to make speed change or adjusting the center for chucking work piece with four-jaw chuck easier, worker can use the jogging button (22) to assist on rotating the spindle momentarily.

### GEAR CHANGE SYSTEM

The gear change system is located at the left side of the headstock as figure shown. (Please refer to threading chart as Chart #1)

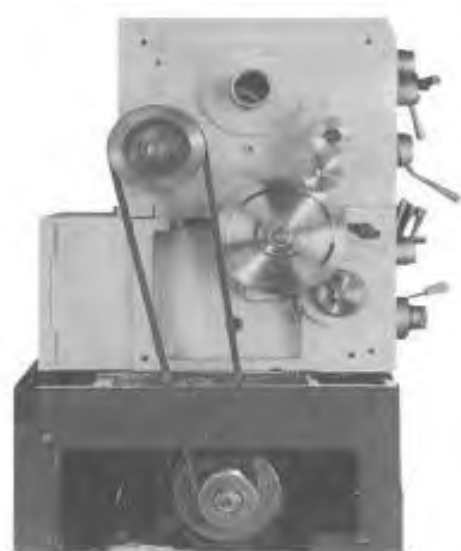

| SPEED RANGE (RPM)<br>Spindle bore 56mm |          | SPEED RANGE (RPM)<br>Spindle bore 85mm |          |
|--|----------|--|----------|
| H                                      | 3100~681 | H                                      | 2250~491 |
| M                                      | 680~153  | M                                      | 490~126  |
| L                                      | 152~33   | L                                      | 125~27   |

| SPEED RANGE (RPM)<br>Spindle bore 105mm |          | SPEED RANGE (RPM)<br>Spindle bore 155mm |         |
|---|----------|---|---------|
| H                                       | 1500~331 | H                                       | 800~176 |
| M                                       | 330~93   | M                                       | 175~53  |
| L                                       | 92~20    | L                                       | 52~10   |

Chart #2

Caution: Do not attempt to change gears while the spindle is still running.

### HOW TO OPERATE THE CARRIAGE & APRON

For longitudinal auto-feeding, please push in the long/cross feeding selection lever (13). But for auto cross feeding, please pull out the selection lever (13) to activate the mechanism.

### MANUAL FEED

Carriage moves longitudinally by turn the longitudinal traverse hand wheel (11), meanwhile, set

the feed directional lever (7) the half-nut engagement lever (14) at neutral position and pull out the long/cross feeding selection lever (13). (One graduation of handwheel dial is corresponding to 0.002” and one revolution corresponds to 0.4” travel of carriage.)

### AUTO FEED

The auto feeding mechanism is operated as the following procedure:

1. Select the feed direction by moving feed directional lever (7).
2. Set gear change and shift levers (8) & (29) to desired feed rate.
3. Shift feed engagement lever (30) to feed direction.
4. Pull the half-nut engagement lever (14) up.
5. Pull or push the long/cross feeding selection lever to either longitudinal or cross feed position.
6. Shift the spindle control lever (19) to forward direction.
7. When the feed engagement lever (30) is shifted, then the auto feed mechanism will start. But when the feed engagement lever (30) is shifted to the neutral position and the auto-feeding mechanism will be stopped immediately.

### SWIVELING THE TOOL POST

If a worker wants to swivel the tool post, he must loosen four way tool post’s carriage locking screws before the action can be done.

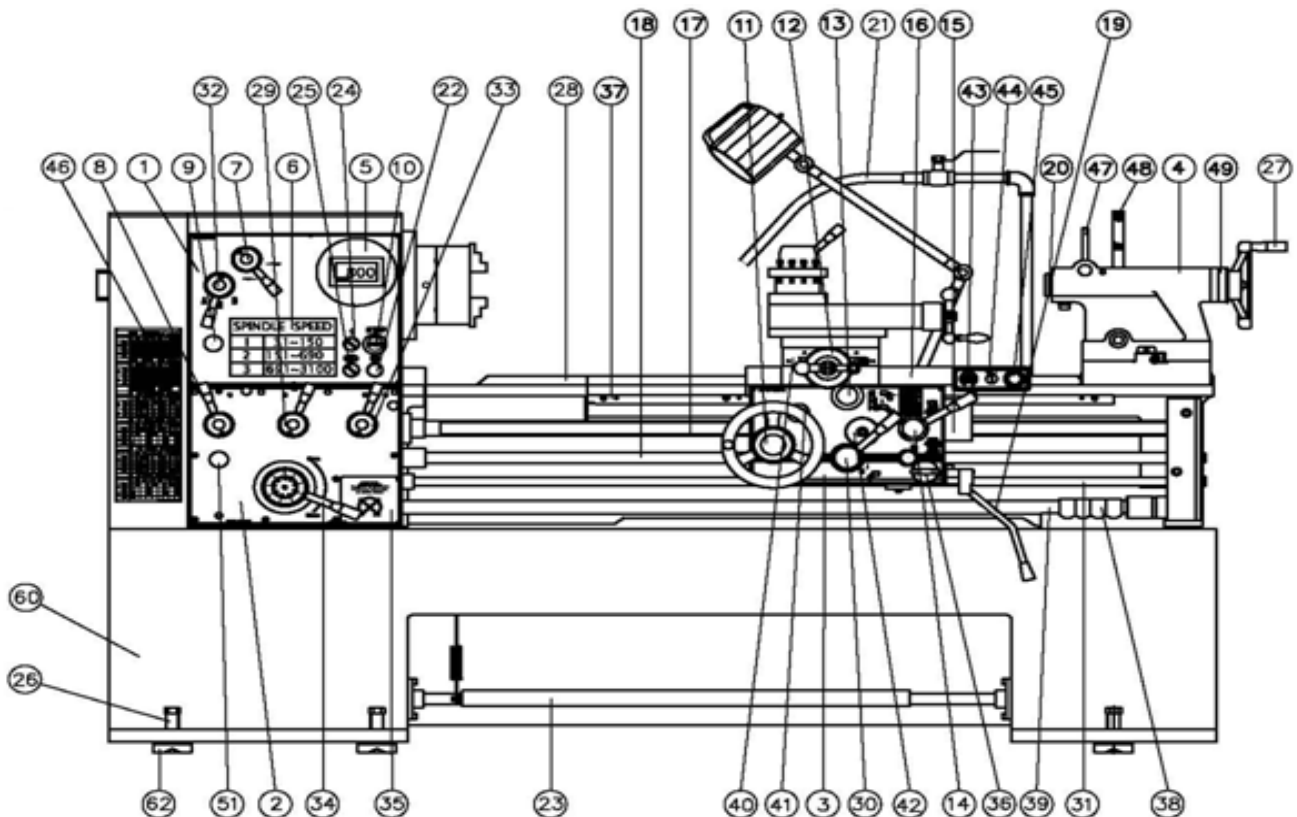

| LEVER |   | ⓕ MM Feed speed |      |      |      |      |      |      |      |      |
|-------|---|-----------------|------|------|------|------|------|------|------|------|
|       |   | 1               | 2    | 3    | 4    | 5    | 6    | 7    | 8    | 9    |
| C     | A | 0.50            | 0.57 | 0.63 | 0.69 | 0.70 | 0.73 | 0.76 | 0.82 | 0.89 |
|       | B | 0.25            | 0.28 | 0.31 | 0.34 | 0.35 | 0.36 | 0.38 | 0.41 | 0.44 |
| D     | A | 0.12            | 0.14 | 0.15 | 0.17 | 0.17 | 0.18 | 0.19 | 0.20 | 0.22 |
|       | B | 0.06            | 0.07 | 0.08 | 0.08 | 0.08 | 0.09 | 0.09 | 0.10 | 0.11 |

There is a dead center fixed in the sleeve of MT#5 and aligned with the center-line of the headstock. It is aligned to the dead center on the tailstock's quill. The dead center on the tailstock can be removed by rotating the hand wheel to the end of stroke. One graduation of the handwheel's dial is corresponding to 0.002", one revolution corresponds to 0.2" travel of tailstock's quill, and the total range of movement of the quill is 6" (150 mm).

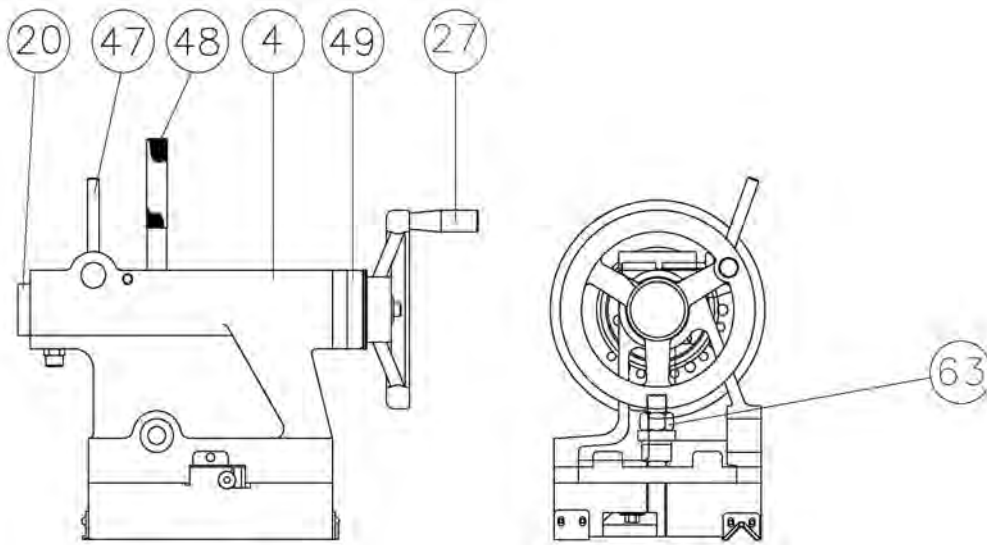

In order to accommodate to the different length of the work piece, the tailstock can slide along the bedways by pushing or pulling it to the required position, and then locked in location by lifting the up quill locking lever (47) until it is tighten.

## THREADING CHART

Chart #1

| LEVER |   | W FOR CUTTING INCH THREAD |    |    |    |    |     |    |    |    |
|-------|---|---------------------------|----|----|----|----|-----|----|----|----|
|       |   | 1                         | 2  | 3  | 4  | 5  | 6   | 7  | 8  | 9  |
| D     | A | 4                         | 4½ | 4¾ | 5  | 5½ | 5¾  | 6  | 6½ | 7  |
|       | B | 8                         | 9  | 9½ | 10 | 11 | 11½ | 12 | 13 | 14 |
| C     | A | 16                        | 18 | 19 | 20 | 22 | 23  | 24 | 26 | 28 |
|       | B | 32                        | 36 | 38 | 40 | 44 | 46  | 48 | 52 | 56 |

| LEVER |   | M FOR CUTTING METRIC THREAD |      |      |       |      |      |      |      |       |
|-------|---|-----------------------------|------|------|-------|------|------|------|------|-------|
|       |   | 1                           | 2    | 3    | 4     | 5    | 6    | 7    | 8    | 9     |
| C     | A | 4                           | 4.5  | 4.75 | 5     | 5.5  | 5.75 | 6    | 6.5  | 7     |
|       | B | 2                           | 2.25 |      | 2.5   | 2.75 |      | 3    | 3.25 | 3.5   |
| D     | A | 1                           |      |      | 1.25  |      |      | 1.5  |      | 1.75  |
|       | B | 0.5                         |      |      | 0.625 |      |      | 0.75 |      | 0.875 |

| LEVER |   | W FOR CUTTING D.P THREAD |    |    |    |    |     |    |     |     |
|-------|---|--------------------------|----|----|----|----|-----|----|-----|-----|
|       |   | 1                        | 2  | 3  | 4  | 5  | 6   | 7  | 8   | 9   |
| D     | A | 8                        | 9  | 9½ | 10 | 11 | 11½ | 12 | 13  | 14  |
|       | B | 16                       | 18 | 19 | 20 | 22 | 23  | 24 | 26  | 28  |
| C     | A | 32                       | 36 | 38 | 40 | 44 | 46  | 48 | 52  | 56  |
|       | B | 64                       | 72 | 76 | 80 | 88 | 92  | 96 | 104 | 112 |

| LEVER |   | M FOR CUTTING MODULE THREAD |      |   |       |      |   |      |      |       |
|-------|---|-----------------------------|------|---|-------|------|---|------|------|-------|
|       |   | 1                           | 2    | 3 | 4     | 5    | 6 | 7    | 8    | 9     |
| C     | A | 2                           | 2.25 |   | 2.5   | 2.75 |   | 3    | 3.25 | 3.5   |
|       | B | 1                           |      |   | 1.25  |      |   | 1.5  |      | 1.75  |
| D     | A | 0.5                         |      |   | 0.625 |      |   | 0.75 |      | 0.875 |
|       | B | 0.25                        |      |   |       |      |   |      |      |       |



## HOW TO OPERATE THE LEADSCREW

When shifting the feed directional lever (7) to the right or left, it will put leadscrew in forward or reverse rotation respectively.

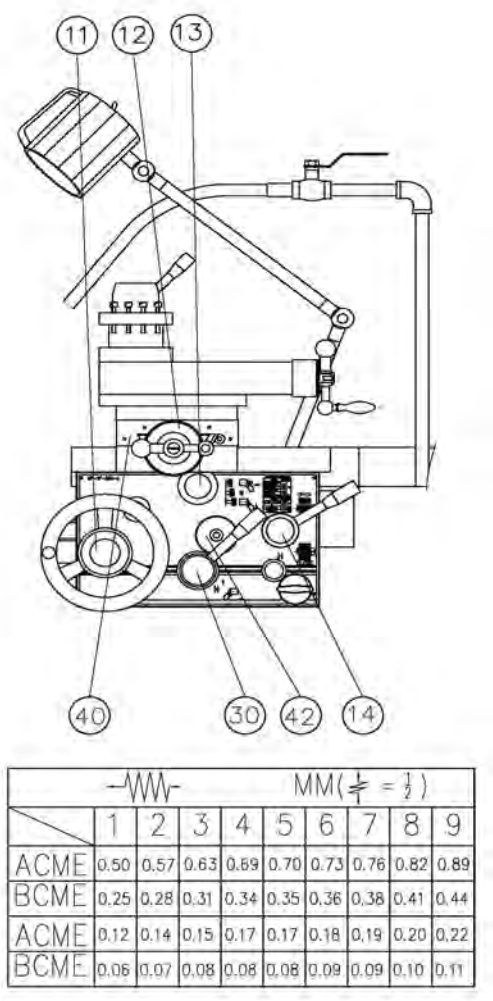

### METRIC / INCH THREAD SYSTEM:

The metric / inch tread cutting is operated as following procedures:

1. The gear change system is aligned for making metric / inch tread cutting.
2. Next, shift levers (8), (29), (33) to the desired position and shift feed selection dial to one of nine position, then engage the feed selection lever to lock it in position.
3. Please shift spindle control lever (19) downward or upward to the spindle forward rotation direction.
4. Push half-nut engagement lever down to start thread cutting.

### THREAD CUTTING CHART

The tread cutting chart is installed on the headstock panel which has nine columns. For making metric/inch thread cutting, the chart will make the action easy, since positions of the feed selection levers are indicated, and by following the chart, worker can engage the half-nut

engagement quickly and conveniently to cut the desired thread.

As for making repeated the metric thread, the half nut should be engaged with leadscrew completely without disengagement when repeating the cut (this is required when the leadscrew has 4 TPI).

To let cutting tool return to starting position, the action is complete by disengage the half-nut engagement lever (14), crank longitudinal handwheel back to starting cutting position, increment the crossfeed, and then engage the half-nut engagement lever (14) again to start thread cutting. When making metric thread cutting using leadscrew of imperial system or vice versa, the half-nut engagement lever (14) has to remain engaged until to the end of thread cutting process.

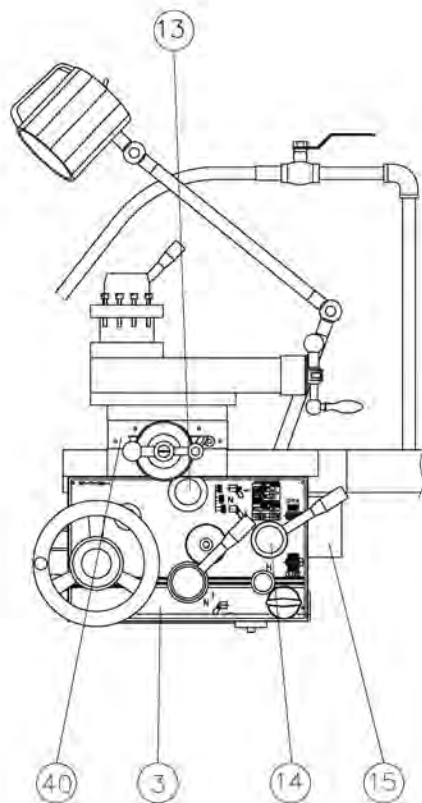

## OPERATION OF SPINDLE (WITH INVERTER CONTROL)

### SELECTING SPINDLE SPEED (LATHE WITH INVERTER CONTROL)

When the lathe is equipped with an inverter control, it provides three speed ranges:

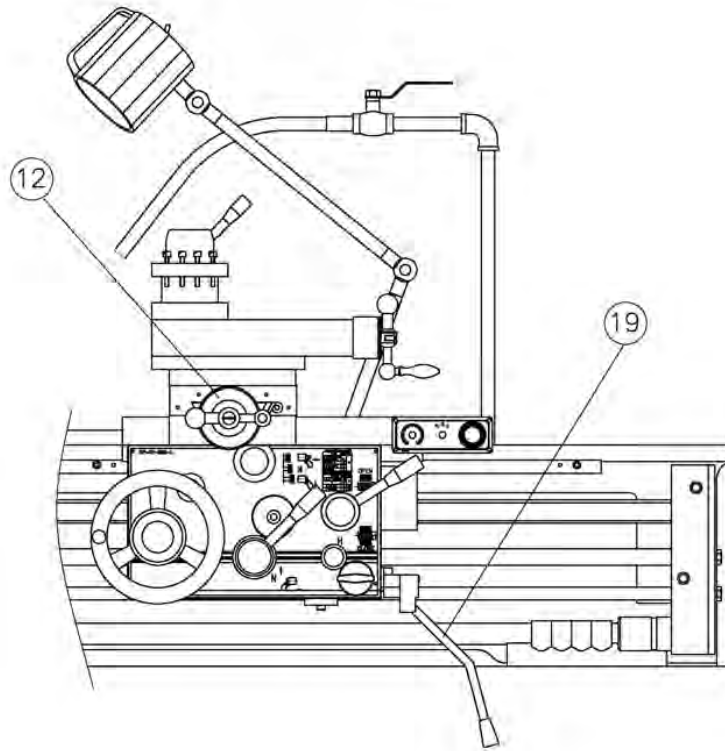

- a. Turn power ON/OFF switch (24) to “ON” position and the indication lamp lights on, it means the machine is under powered condition.
- b. According to speed chart indication, set the speed selection switch (44) for selecting the “H, M, L” speed range. Then the spindle will automatically change to your speed setting.
- c. Use the spindle control lever (19) to start motor running and control the spindle rotation that is running clockwise or counter-clockwise.
- d. Use the speed turning knob (43) to set your desired turning speed. The digitally displayed spindle speed is indicated on the spindle speed display (5), located on the headstock.

## STOP AND RE-START SPINDLE (LATHE WITH INVERTER CONTROL)

1. To stop the spindle rotation, press the emergency switch (45) or step on the brake pedal.
2. To restart the spindle rotation, pull up/push down the lever (19).

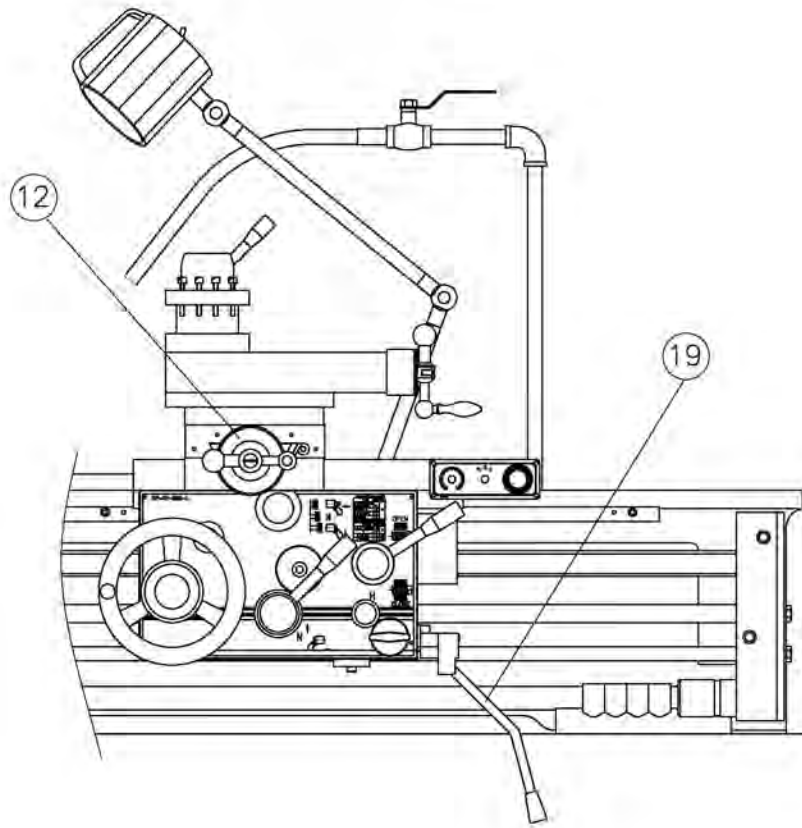

## **OPERATION INSTRUCTION FOR AUTOMATIC SPEED CHANGE**

1. To perform automatic speed change, worker uses speed turning knob (43) and speed selection switch (44) to adjust speed range and fine turn the final speed.
2. To use “H” speed range, simply turn the speed selection knob to “H” position.
3. During speed change, the warning light on the electric cabinet will keep on flashing until speed change motion is complete.
4. When changing speed range, the spindle will start braking automatically, and then rotate slowly to allow speed range change smoothly.
5. Speed-range changing time requires about 7~8 seconds to complete the action.
6. Once speed-range change is finished, the spindle will automatically accelerate to the speed set by the speed turning knob (43).
7. Turn the speed turning knob to re-set your desired speed in the “H” speed range.
8. If a brake action is operated before changing speed, you must restart with the spindle control lever (19) to run spindle in clockwise or counter-clockwise rotation.

## **CALCULATING SPINDLE SPEED**

The function of the speed turning knob (43) and speed selection switch (44) is used to adjust the spindle speed, which changes according to the length, material and diameter of a work piece.

For example:

Work piece diameter:  $\varnothing 60\text{mm}$

Work piece material: mild carbon steel (S45C)

Cutting length: 150mm

1. The spindle speed is calculated as below:

$$150 (M) \times 1000\text{mm} \div (60\text{mm} \times 3.1416) = 796 \text{ rpm}$$

2. If cutting length is 200mm and other conditions are same, the spindle speed is calculated as below:

$$200 (M) \times 1000\text{mm} \div (60\text{mm} \times 3.1416) = 1061 \text{ rpm}$$

## **BENEFIT OF USING TAPER TURNING ATTACHMENT**

1. When using taper turning attachment, the side position of the tailstock needs not to shift. This allows center of tailstock staying the same as the headstock, and will have an easier taper cut process.
2. Cutting ID taper hole is easily done with taper turning attachment. The processes of it are the same as cutting outer taper except the rotation of the screw is reversed.
3. If work piece needs a larger taper, worker needs to move tailstock side-ways to accommodate for the larger angle.

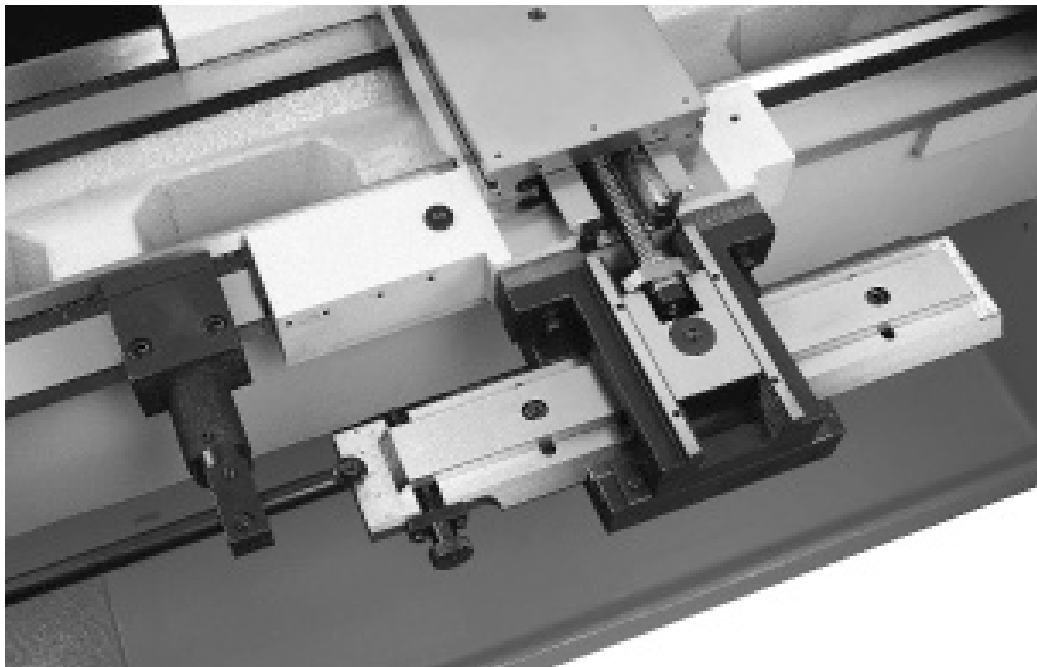

## **OPERATION OF TAPER TURNING ATTACHMENT**

1. Please double check to see if the taper turning attachment is installed correctly before operation.
2. Adjusting the taper turning attachment to the center position the work piece.
3. Attachment holding bracket is secured with locating rod.
4. Install tool post with a round nose cutting tool, and make sure it is located at the center cut line.

**Note: If the cutting tool is slightly above or below the center cut line, the resulting taper angle will be different from the pre-set angle.**

5. Chucking the work piece on the lathe. It is recommended to cut from the small taper side to the larger side.
6. Please make sure cross-slide and taper slide are moving smoothly and have no up down movement.
7. Crank longitudinal handwheel to check if its travel is enough to cut the work piece's required taper. If it is not enough, please adjust tool post, saddle or taper attachment to the proper position.
8. Lock taper slide to the angle desired.
9. Please move saddle to the small taper side, and make sure cutting tool is off from work piece at around 1" length.
10. Turn in the crossfeed handwheel until cutting tool is slightly touching the work piece.
11. Crank longitudinal handwheel to move saddle until cutting tool is cutting the work piece. At this point, worker may engage automatic cutting mechanism.
12. Cut work piece continuously until 1/3 length is achieved.
13. Stop cutting, and use dial indicator or caliper to measure taper angle. If higher angle accuracy is required, please use angle gauge to measure the angle cut.
14. If necessary, please adjust the taper slide again until the correct angle is found.
15. At this point, if no adjustment is needed, please continue to cut the work piece until the work piece is done.

## **LUBRICATION**

### **LUBRICATION IN HEADSTOCK & GEARBOX:**

These two items are oil bath lubricated; please always make sure the oil level is not lower than the minimum level of oil gauge.

### **LUBRICATION IN GEAR CHANGE SYSTEM:**

Open the protecting cover (located on left hand side of the headstock) of gear change system and drip lubrication oil daily.

### **LUBRICATION IN CARRIAGE & TOOL POST:**

Carriage slide is lubricated by pulling lube pump handle on the apron, and the tool post is lubricated with drip oiler before starting the machine daily.

### **LUBRICATION IN APRON:**

The apron itself is served as an oil reservoir. Its rotating parts are dipped into the oil bath and the other parts are lubricated by oil splashing. Be sure the oil level on the oil gauge is at proper height when operating!

### **COOLANT FLUID FOR CUTTING:**

The coolant pump must turn on when the machining is in process, and turn the coolant on/off switch (25) to on position.

### **LUBRICATION OIL:**

#### **1. HEADSTOCK & FEED GEARBOX**

|                  |             |           |
|------------------|-------------|-----------|
| MOBIL            | ESSO        | SHELL     |
| DTE HEAVY MEDIUM | TELLESSO 52 | FELLUS 32 |

#### **2. APRON, COMPOUND, TAILSTOCK, LEADSCREW, SLIDEWAYS AND CARRIAGE SCREW**

|           |            |              |
|-----------|------------|--------------|
| MOBIL     | ESSO       | SHELL        |
| VACTRA #2 | FEHIS K-53 | TONNA OIL 27 |

#### **3. CHANGE GEARS**

Grease

43

44



45



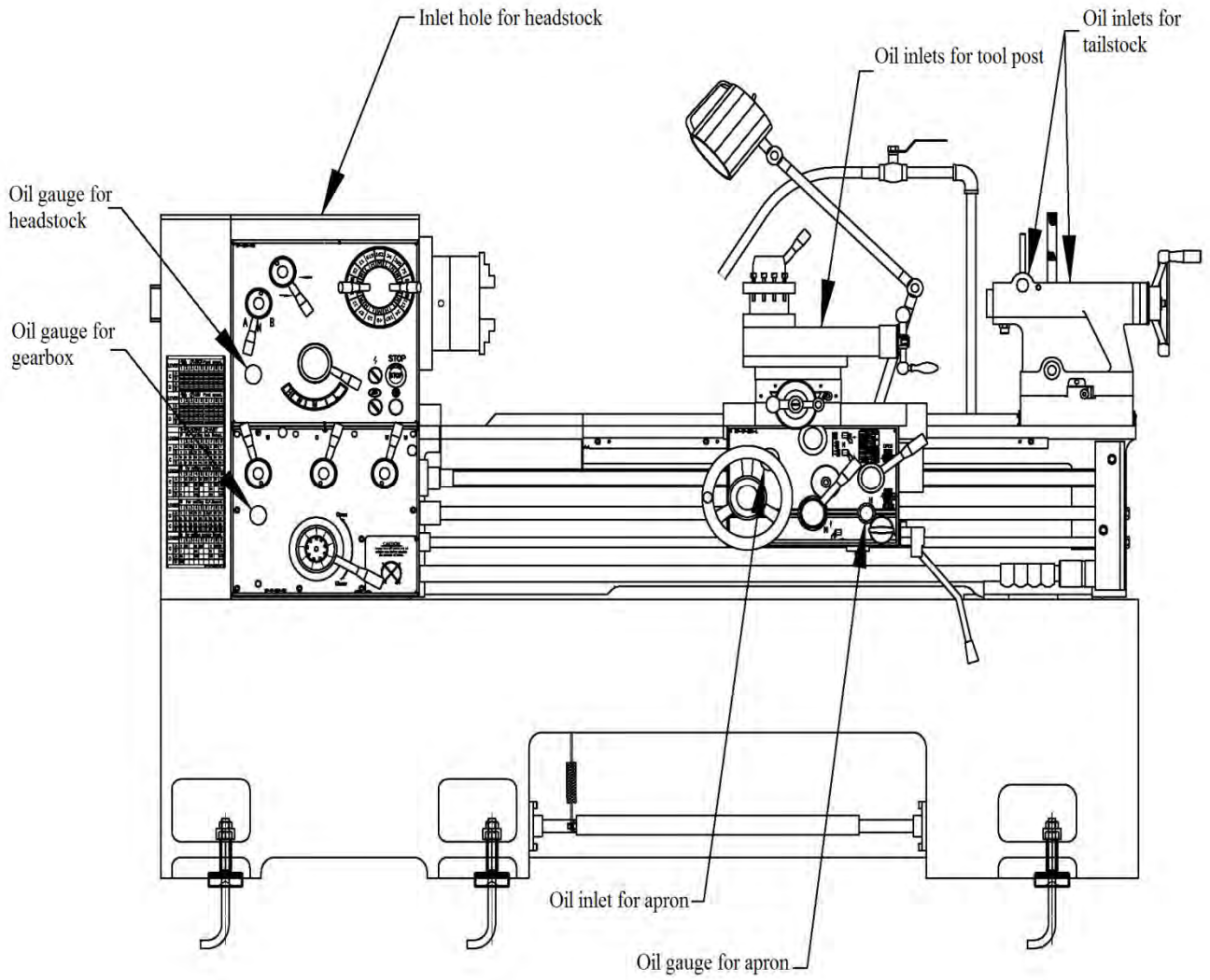





# OIL INLET POINTS



# LUBRICATION SCHEDULE

|                         |   |   |   |
|-------------------------|---|---|---|
|                         |  |  |  |
| Lubrication<br>Schedule | Everyday  | When needed   | Oil level must be<br>above center line  |

|   |   |   |
|---|---|---|
|  |  |  |
|  |  |  |

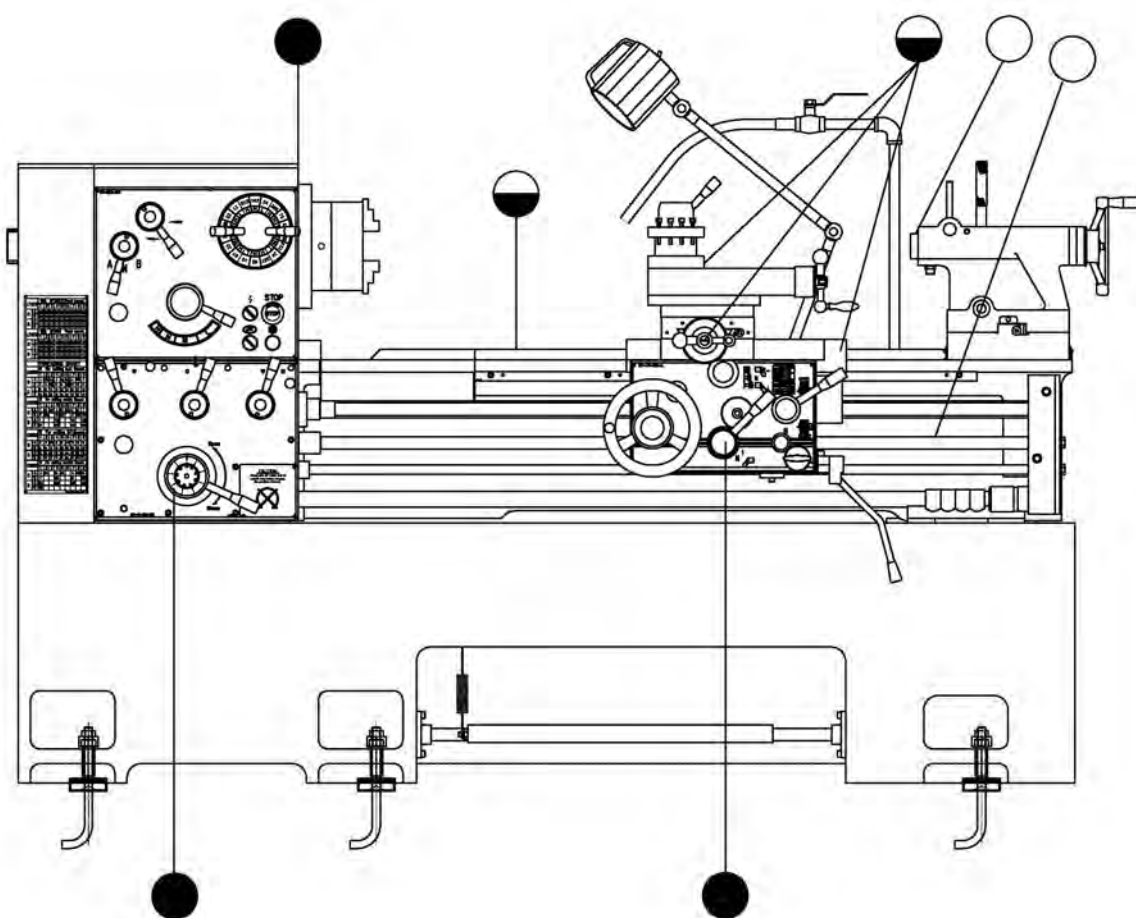

**TROUBLE CAUSE & TROUBLE SHOOTING**

| TROUBLE ITEM   | CAUSE  | REMEDY   |
|--|--|--|
| Vibration  | Loose leveling screws  | Set all screws so they bear evenly on leveling plates.   |
|  | Torn or mismatched Vee belts   | Replace vee belts with matched set, or adjust roll.  |
|  | Work of chuck out of balance operating at high spindle speed                           | Balance chuck or reduce spindle speed.   |
|  | Motor out of balance   | Contact local representative or motor manufacturer.  |
| Chatter  | Tool bit improperly ground or not on center  | Regrind tool bit or adjust tool holder so that the area of the contact between tool bit and work is decrease. Avoid extreme negative rake angle. |
|  | Tool overhand too much   | Keep point of tool bit as close as possible to tool holder.  |
|  | Using improper surface feed rate.  | Reduce or increase spindle speed.  |
|  | Feed rate too high or too low.   | Reduce or increase feed rate.  |
|  | Gibs of cross-slide or compound rest is loose.   | Adjust gibs.   |
|  | Spindle bearings worn.   | Adjust spindle bearings.   |
|  | Work piece improperly supported.   | Adjust tailstock center. Use steady rest or follow rest on long slender shafts. Minimize tailstock barrel extension.                             |
|  | Vibration  | See "Vibration" trouble shooting above.  |
| Workpiece not turning round  | Work loose between centers or centers are excessively worn--work centers out of round. | Adjust tailstock center. Regrind centers, Lap work centers.  |
|  | Loose headstock spindle bearings.  | Adjust headstock spindle bearings.   |
| Workpiece not turning straight   | Headstock and tailstock centers are not aligned.                                       | Align tailstock centers  |
|  | Workpiece is improperly supported.   | Use steady rest or follow rest. Reduce overhang from chuck.  |
|  | Machine bed is not leveled.  | Relevel bed by using precision level.  |
|  | Tool not on center when using taper turning attachment.                                | Align tool on centers.   |
| Cross-slide or compound rest movement does not coincide with dial movement of respective axes. | Gib setting too tight or too loose.  | Adjust gibs.   |
|  | Workpiece is too long and slender.   | Use steady rest or follow rest.  |

## ADJUSTMENT OF MACHINE COMPONENTS

### Spindle Headstock Adjustment

If the alignment of the spindle and tailstock is off, please following the procedure to re-align the components.

1. Prepare one gauge bar at 24" (600mm) in length and one dial indicator with base.
2. Please have the gauge bar firmly fixed between the dead centers of the headstock and tailstock.
3. Locate the dial indicator base on the top slide and have the dial indicating on the gauge bar.
4. Slightly move the top slide in and out to read the movement of the dial. Make sure the movement is about 15~20 graduations on the dial.
5. Then if needed, rotate the dial to zero position.
6. Crank longitudinal handle to move saddle left and right.
7. If there is mis-alignment, there will be reading from the dial, ie, movement on the dial.
8. If the alignment is OK, the dial will not move thru out the movement.

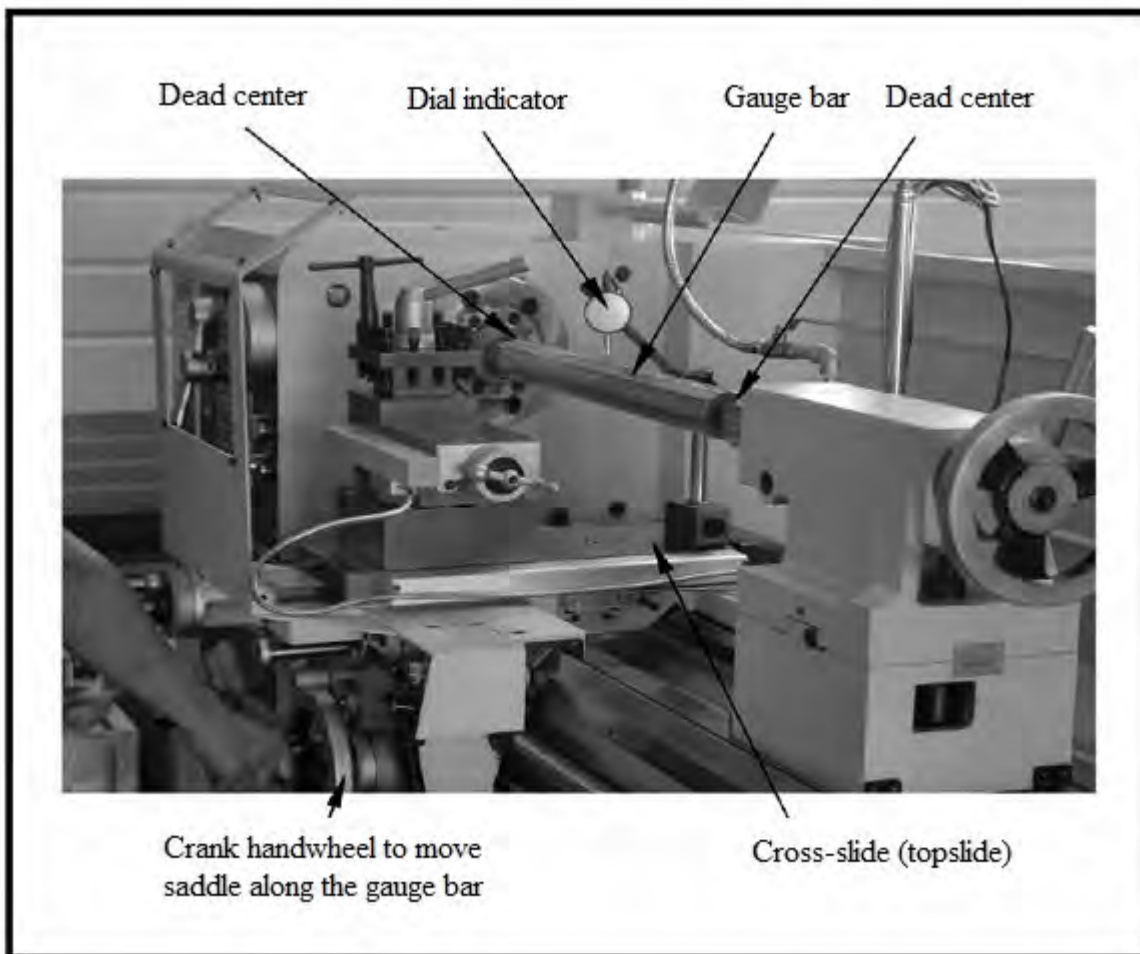

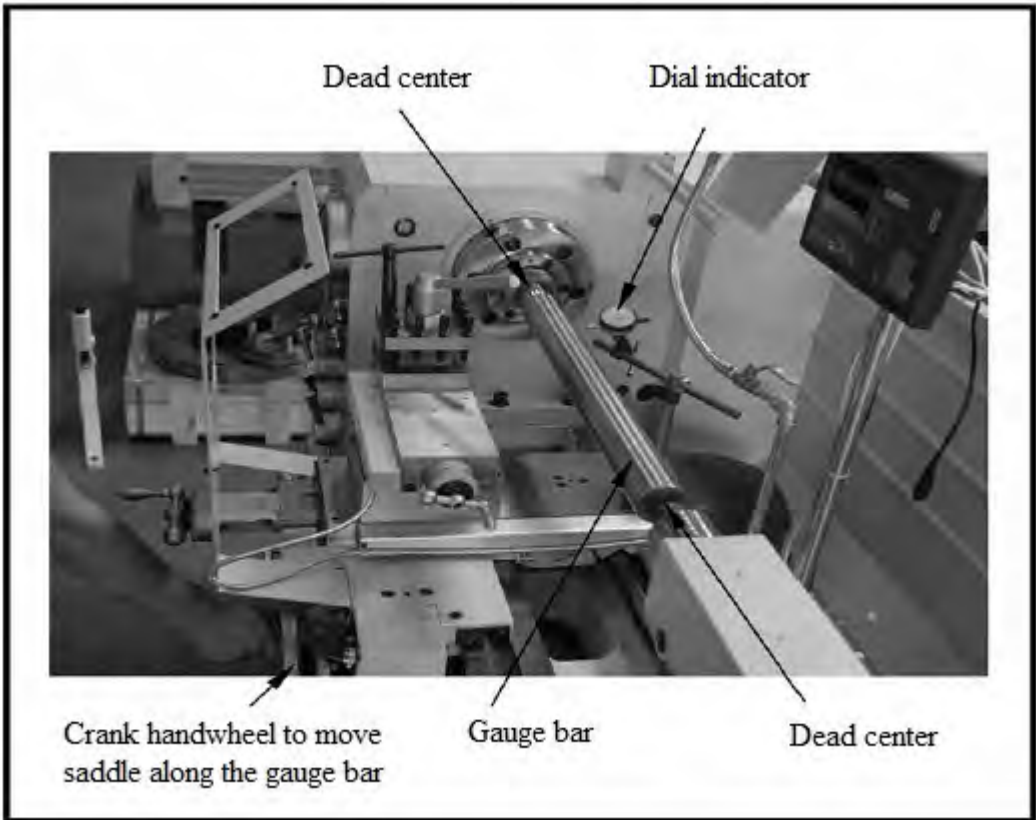

If headstock is mis-aligned, please adjust the screws on the headstock shown on the drawing below.

1. If headstock needs to adjust toward user, please release locking screw #1, then tightening in adjustment screw #2. Next is to relocking in locking screw #1.
2. If headstock needs to adjust away from user, please release locking screw #3, then tightening in adjustment screw #4. Next is to relocking in locking screw #3.

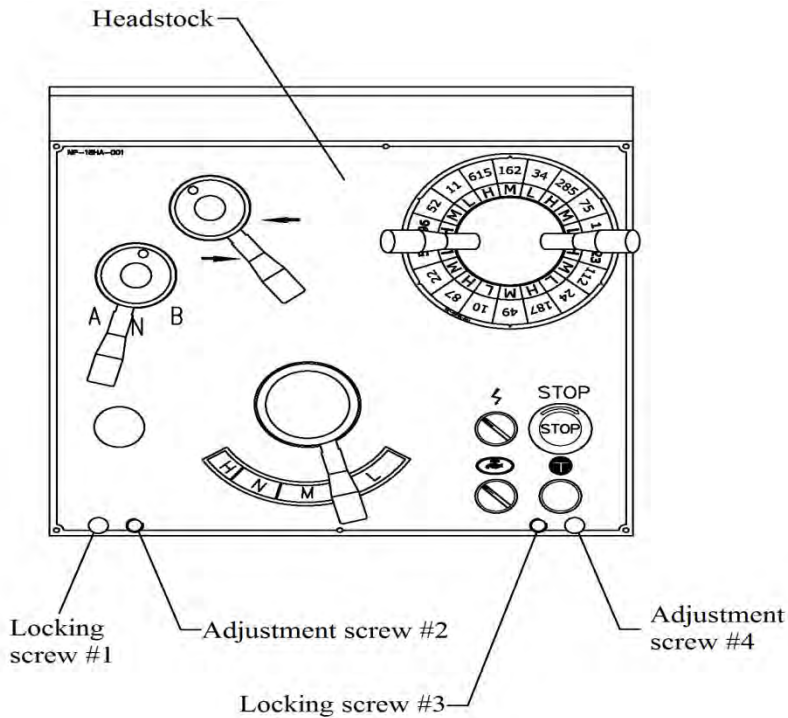

## V-belt of Spindle

V-belts for the spindle must be checked periodically. If the belt tension is too loose, it will reduce the cutting performance of the lathe. If the belts are too tight, it will decrease the life-span of the spindle bearings, other components to wear out quicker.

### Adjustment for the V-belts

1. Turn of the machine's power.
2. Please open left side cover of the machine base.
3. If tightening the belts is needed, #58, please release lower side hex nut, screw down the top hex nut, and repeat the procedure until desired tension is achieved.
4. If loosening the belts is needed, please release top side hex nut, screw the lower side hex nut upward, and repeat the procedure until desired tension is achieved.
5. Top and down sides have total of four hex nuts. They are located on left and right side of the motor plate looking from the back of the headstock. When adjusting the hex nuts, please make sure both left and right side's hex nuts are loosen or tighten. Without doing this correctly, V-belts may wear out prematurely and create unnecessary vibration when working.

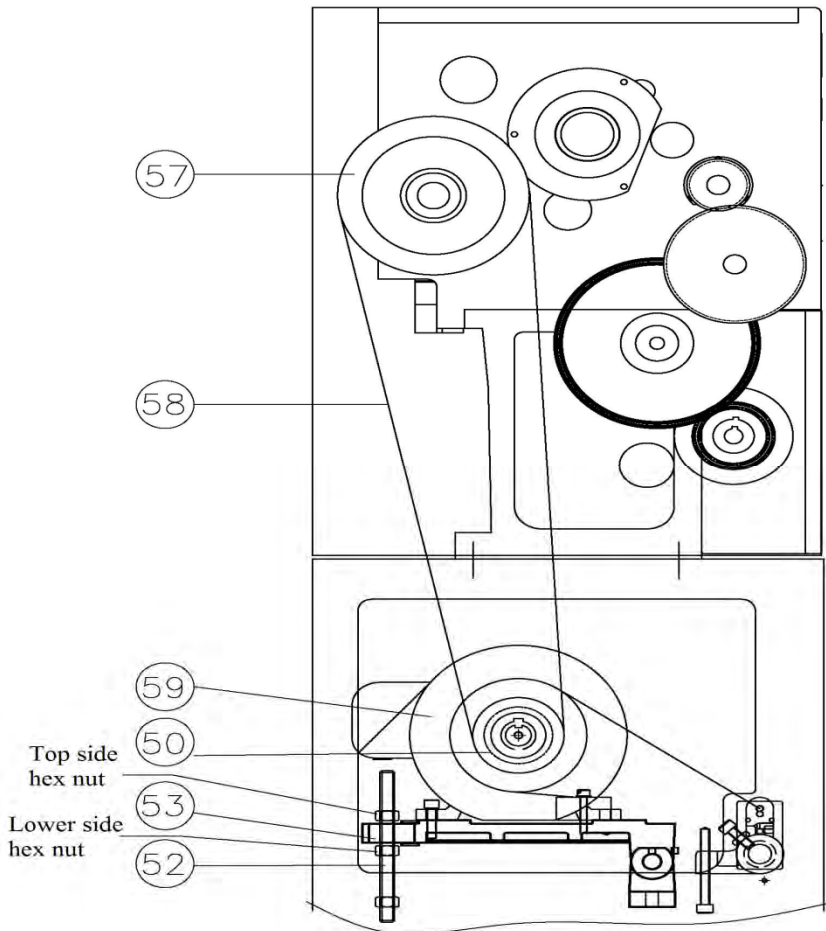

## Adjustment of Crossfeed Leadscrew

After using the lathe for a few months, the crossfeed leadscrew will have some wear and creating some backlash between the nuts and the screw. In order to take out the backlash, please use an allen wrench to adjust the adjustment screw until a desired backlash movement is achieved.

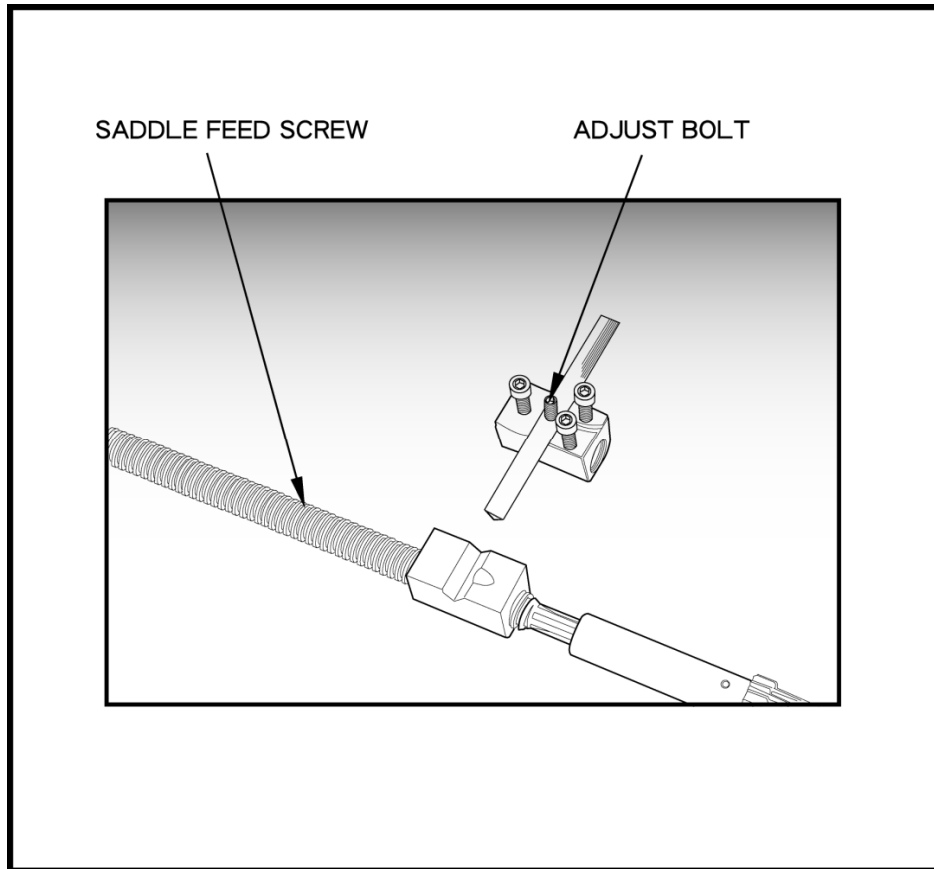

### Adjustment of Saddle Gib

There is a gib located between saddle and bedways. If there is too much play between them, please adjust this gib.

The procedure for adjusting the gib is such,

1. Release the locking hex nuts.
2. Rotate the adjustment screws clockwise to tightening the gib.
3. After desired tightness is achieved, please retighten the hex nuts.

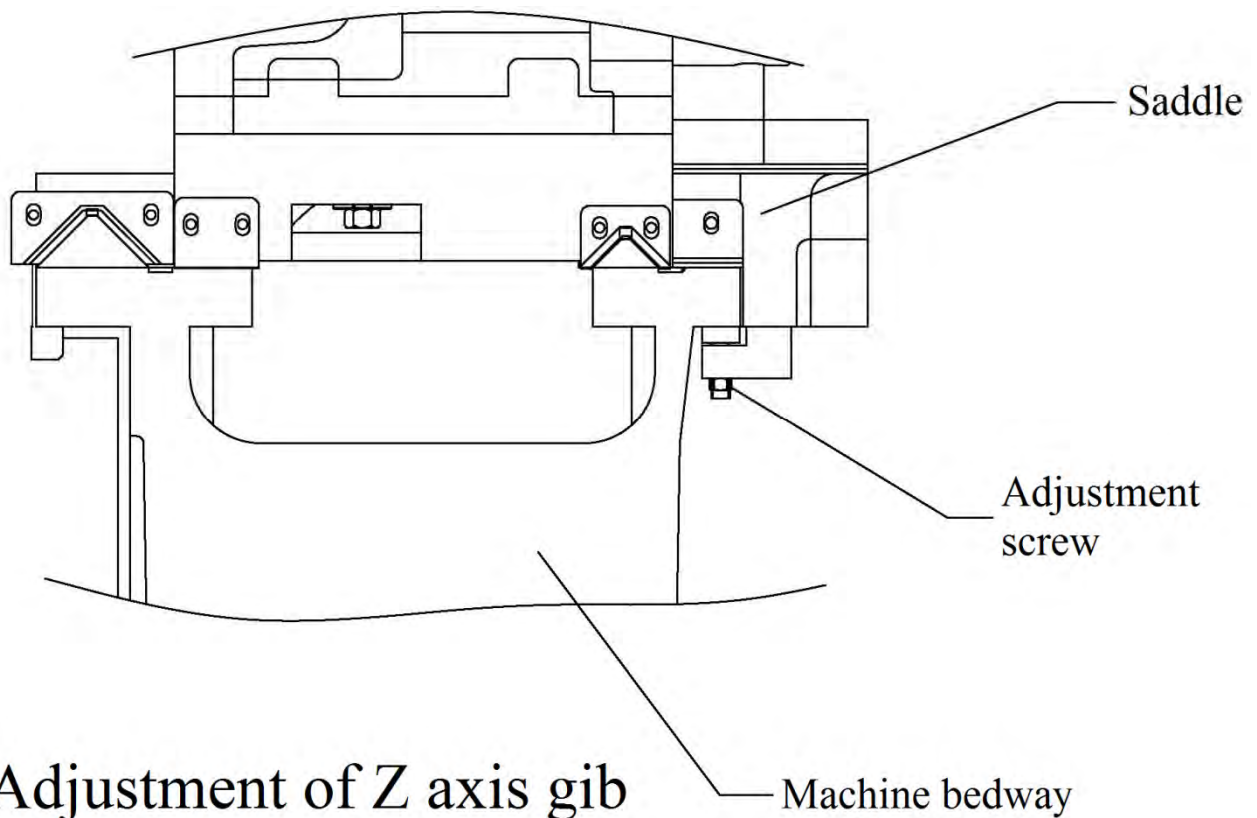



### Adjustment of the gib between Saddle and Cross-slide

There is a gib located between saddle and cross-slide. If there is too much play between them, please adjust this gib.

To adjust the play between the two components, please follow the procedure below.

1. Release the back end gib screw.
2. Screw in the gib screw from the front end. The gib will move in until the gib screw is not able to rotate.
3. After desired play or backlash is achieved, please tightening the back end gib screw again to firmly fix the position of the gib.

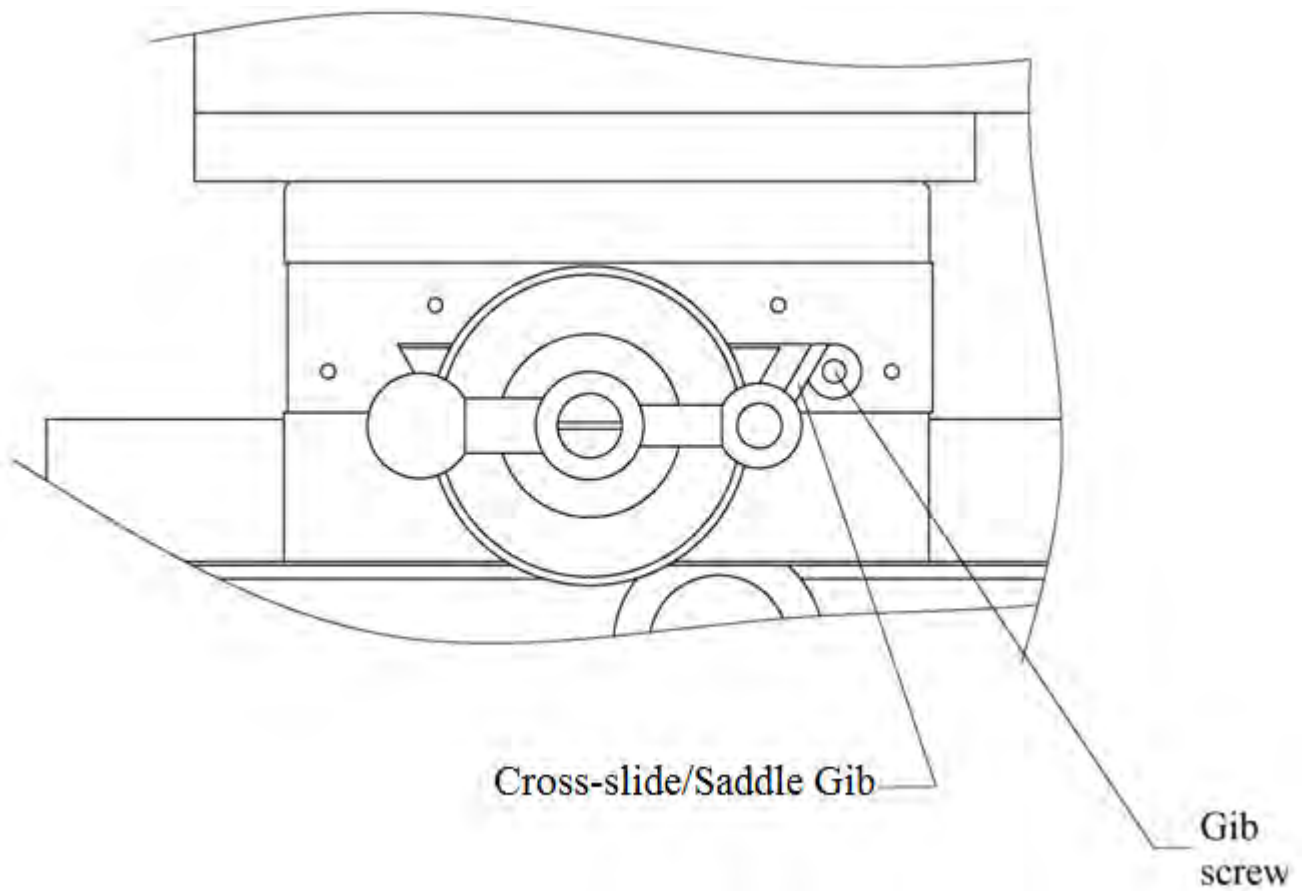

## **REPLACEABLE COMPONENTS ON THE MACHINE**

1. Brake shoe
2. V-belt
3. Leadscrews and their nuts
4. Lubrication oil
5. Way wipers
6. Coolant

# MECHANICAL DRAWINGS & PART BREAKDOWN LIST

Note: When ordering parts, please be prepared with,

1. Machine model & serial number.
2. Item number.
3. Part number and description.
4. Year of Production.
5. Voltage & horsepower.
6. Quantity

**INVERTER LATHE  
HEADSTOCK \_ 21/25 HC, SPINDLE BORE 85MM (3")**

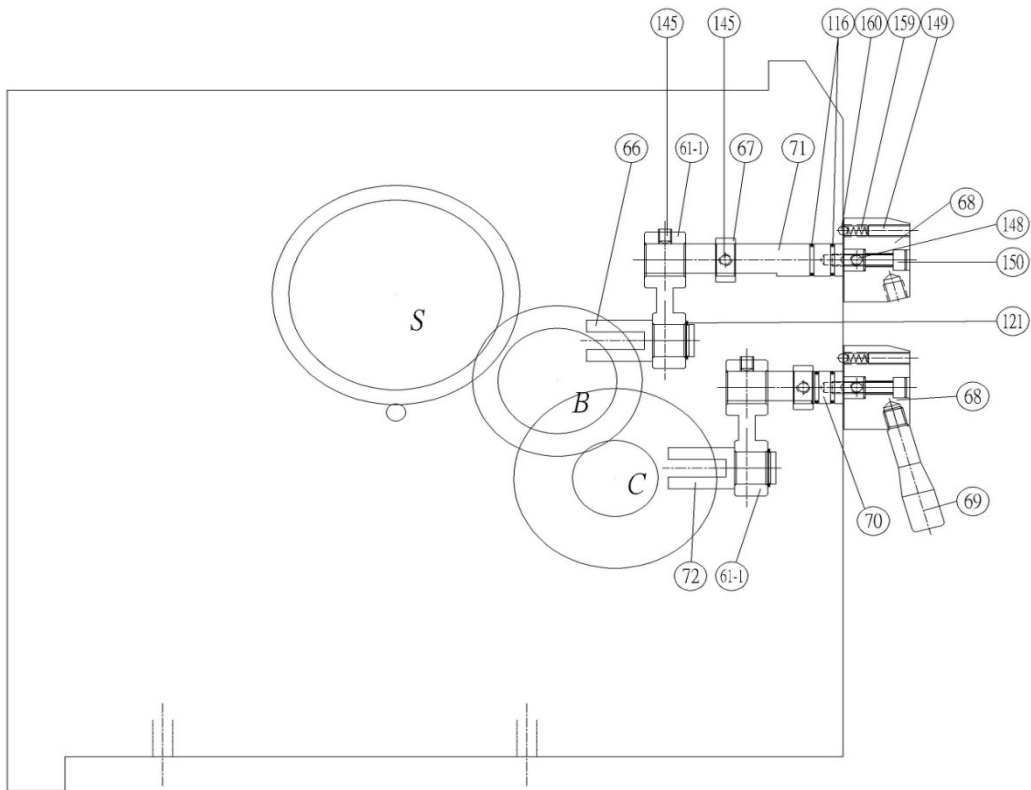
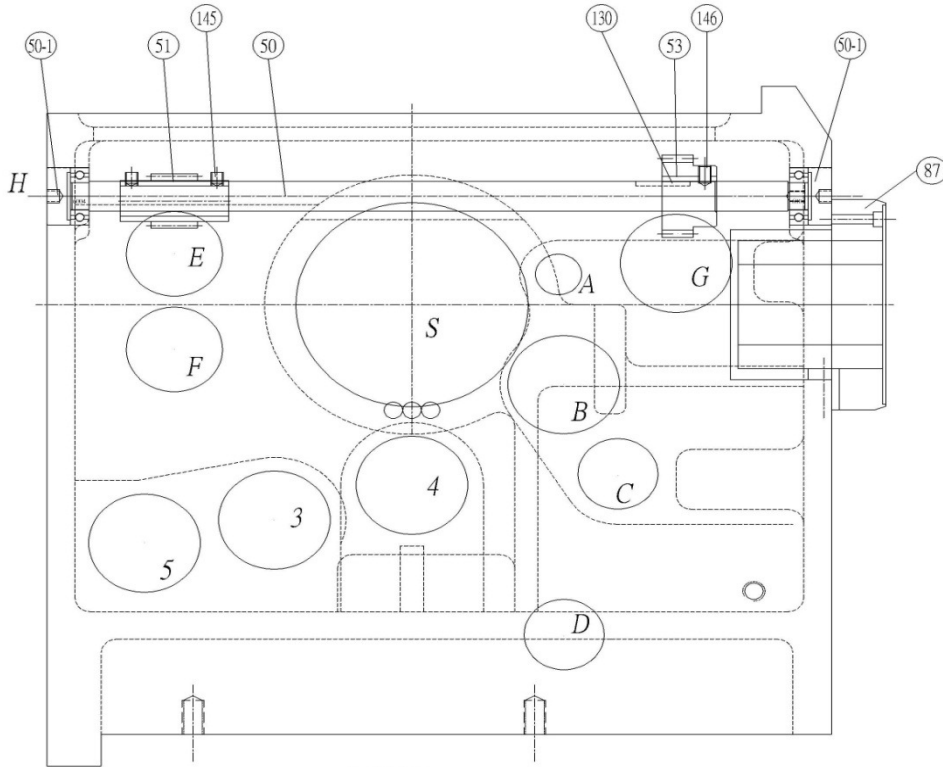

PARTS LIST OF 21/25HC HEADSTOCK\_ SPINDLE BORE 85MM (3")

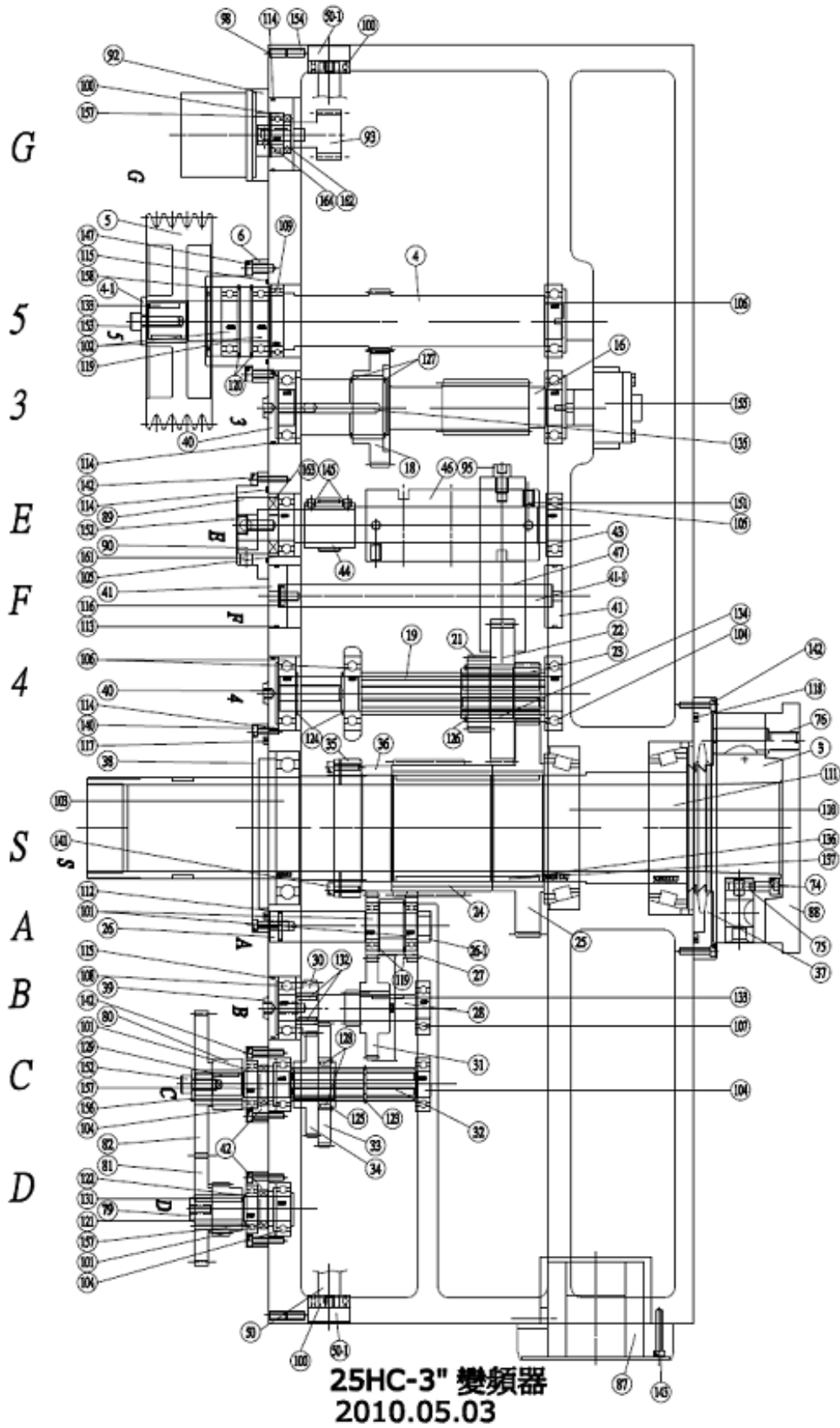

| PARTS LIST OF 21/25HC HEADSTOCK_ SPINDLE BORE 85MM (3'') 2010.05.03 |             |             |      |        |
|---|-------------|-------------|------|--------|
| ITEM  | PARTS NO.   | DESCRIPTION | Q'TY | REMARK |
| 001   | 18HC-001000 | HEADSTOCK   | 1    |        |
| 002   | 25HA-002000 | COVER       | 1    |        |
| 003D  | 18HA-0030D0 | SPINDLE     | 1    |        |
| 004   | 18HB-0041A0 | SHAFT       | 1    |        |
| 004-1   | 18HB-004100 | SPACER      | 1    |        |
| 005   | 18HA-0052A0 | V-PULLEY    | 1    |        |
| 006   | 18HA-006A00 | COVER       | 1    |        |
| 016   | 18HA-016000 | SHAFT       | 1    |        |
| 018   | 18HA-018000 | GEAR        | 1    |        |
| 019   | 18HA-019000 | SHAFT       | 1    |        |
| 021   | 18HA-021000 | GEAR        | 1    |        |
| 022   | 18HA-022000 | GEAR        | 1    |        |
| 023   | 18HA-023000 | GEAR        | 1    |        |
| 024   | 18HA-024000 | GEAR        | 1    |        |
| 025   | 18HA-025000 | GEAR        | 1    |        |
| 026   | 18HA-026100 | SHAFT       | 1    |        |
| 027   | 18HA-027000 | GEAR        | 1    |        |
| 028   | 18HA-028000 | SHAFT       | 1    |        |
| 030   | 18HA-030000 | GEAR        | 1    |        |
| 031   | 18HA-031000 | GEAR        | 1    |        |
| 032   | 18HA-032000 | SHAFT       | 1    |        |
| 033   | 18HA-033000 | GEAR        | 1    |        |
| 034   | 18HA-034000 | GEAR        | 1    |        |
| 035   | 18HA-035000 | LOCKING NUT | 1    |        |
| 036   | 18HA-036000 | BUSHING     | 1    |        |
| 037   | 18HA-037000 | COVER       | 1    |        |
| 038   | 18HA-038000 | COVER       | 1    |        |
| 039   | 18HA-039000 | COVER       | 1    |        |
| 040   | 18HA-040000 | COVER       | 2    |        |
| 041   | 18HA-041000 | COVER       | 1    |        |
| 041-1   | 18HA-041100 | SHAFT       | 1    |        |
| 042   | 18HA-042000 | COVER       | 2    |        |
| 043   | 18HB-017000 | CAMSHAFT    | 1    |        |
| 044   | 18HB-021000 | GEAR        | 1    |        |
| 046   | 18HB-022000 | CAM         | 1    |        |

| ITEM  | PARTS NO.   | DESCRIPTION             | Q'TY | REMARK |
|-------|-------------|-------------------------|------|--------|
| 047   | 18HB-023000 | SPEED CHANGE FORK       | 1    |        |
| 050   | 25HB-024000 | SHAFT                   | 1    |        |
| 050-1 | 18HB-024100 | STUFF                   | 1    |        |
| 051   | 18HB-025000 | WORM GEAR               | 1    |        |
| 053   | 18HB-026000 | GEAR                    | 1    |        |
| 061-1 | 18HA-061100 | HANDLE FOR SPEED CHANGE | 2    |        |
| 066   | 18HA-066000 | SPEED CHANGE FORK       | 1    |        |
| 067   | 18HA-067000 | RING FOR SPEED CHANGE   | 2    |        |
| 068   | 18HA-068000 | LEVER BASE              | 2    |        |
| 069   | 18HA-069000 | HANDLE FOR SPEED CHANGE | 2    |        |
| 070   | 18HA-070000 | SHAFT FOR SPEED CHANGE  | 1    |        |
| 071   | 25HA-071000 | SHAFT FOR SPEED CHANGE  | 1    |        |
| 072   | 18HA-072000 | SPEED CHANGE FORK       | 1    |        |
| 074   | 18HA-074000 | COUNTER SINK SCREW      | 6    |        |
| 075   | 18HA-075000 | CAM                     | 6    |        |
| 076   | 18HA-076000 | SHORT COLUMN            | 6    |        |
| 079   | 18HA-079000 | SHAFT                   | 1    |        |
| 080   | 18HA-080000 | BASE FOR SAFE BOLT      | 1    |        |
| 081   | 18HA-081000 | GEAR                    | 2    |        |
| 100   |             | BEARING 6004ZZ          | 3    |        |
| 101   |             | BEARING 6005            | 2    |        |
| 102   |             | BEARING 6005ZZ          | 2    |        |
| 103   |             | BEARING 6008            | 2    |        |
| 104   |             | BEARING 6014Z           | 1    |        |
| 105   |             | BEARING 6205            | 3    |        |
| 106   |             | BEARING 6206            | 2    |        |
| 107   |             | BEARING 6207            | 6    |        |
| 108   |             | BEARING 6304            | 1    |        |
| 109   |             | BEARING 6305            | 1    |        |
| 110   |             | BEARING 6910            | 1    |        |
| 111   |             | BEARING 32016XJ         | 2    |        |
| 112   |             | O RING G25              | 1    |        |
| 113   |             | O RING G55              | 2    |        |
| 114   |             | O RING G65              | 4    |        |
| 115   |             | O RING G75              | 1    |        |
| 116   |             | O RING G120             | 1    |        |

| PARTS LIST OF 21/25HC HEADSTOCK_ SPINDLE BORE 85MM (3'') 2010.05.03 |           |                  |      |        |
|---|-----------|------------------|------|--------|
| ITEM  | PARTS NO. | DESCRIPTION      | Q'TY | REMARK |
| 117   |           | O RING P18       | 5    |        |
| 118   |           | O RING P170      | 1    |        |
| 119   |           | C LOCKER R47     | 2    |        |
| 120   |           | C LOCKER R68     | 2    |        |
| 121   |           | C LOCKER S20     | 1    |        |
| 122   |           | C LOCKER S22     | 3    |        |
| 123   |           | C LOCKER S25     | 1    |        |
| 124   |           | C LOCKER S32     | 1    |        |
| 125   |           | C LOCKER S35     | 2    |        |
| 126   |           | C LOCKER S55     | 2    |        |
| 127   |           | KEY 6*6*25       | 1    |        |
| 128   |           | KEY 6*6*36       | 1    |        |
| 129   |           | KEY 6*6*45       | 1    |        |
| 130   |           | KEY 8*7*18       | 2    |        |
| 131   |           | KEY 8*7*28       | 3    |        |
| 132   |           | KEY 10*8*25      | 2    |        |
| 133   |           | KEY 10*8*40      | 2    |        |
| 134   |           | KEY 10*8*80      | 2    |        |
| 135   |           | CAP SCREW M6*16  | 2    |        |
| 136   |           | CAP SCREW M6*20  | 5    |        |
| 137   |           | CAP SCREW M6*30  | 16   |        |
| 138   |           | CAP SCREW M6*35  | 3    |        |
| 139   |           | CAP SCREW M8*20  | 4    |        |
| 140   |           | CAP SCREW M8*30  | 2    |        |
| 141   |           | CAP SCREW M10*25 | 2    |        |
| 142   |           | CAP SCREW M10*40 | 1    |        |
| 143   |           | SET SCREW M6*6   | 1    |        |
| 144   |           | SET SCREW M8*8   | 8    |        |
| 145   |           | SET SCREW M8*10  | 1    |        |
| 146   |           | SET SCREW M8*18  | 4    |        |
| 147   |           | SET SCREW M8*20  | 3    |        |
| 148   |           | SET SCREW M8*40  | 2    |        |
| 149   |           | SET SCREW M10*10 | 4    |        |
| 150   |           | SET SCREW M10*16 | 2    |        |
| 151   |           | SET SCREW 1/4 PT | 2    |        |



| PARTS LIST OF 21/25HC HEADSTOCK_ SPINDLE BORE 85MM (3") 2010.05.03 |           |                  |      |        |
|--|-----------|------------------|------|--------|
| ITEM   | PARTS NO. | DESCRIPTION      | Q'TY | REMARK |
| 152  |           | OIL SEAL 20*38*7 | 1    |        |
| 153  |           | OIL SEAL 25*38*7 | 2    |        |
| 154  |           | OIL SEAL 40*68*7 | 1    |        |
| 155  |           | NUT M8           | 2    |        |
| 156  |           | SPRING WASHER M8 | 2    |        |
| 157  |           | SPACER M10       | 2    |        |
| 158  |           | Oil Pump         | 1    |        |
| 159  |           | SPRING $\phi$ 6  | 2    |        |
| 160  |           | BALL $\phi$ 6    | 2    |        |
| 161  |           | SENSOR           | 3    |        |

# HEADSTOCK \_ 21/25 HC, SPINDLE BORE 105MM (4")

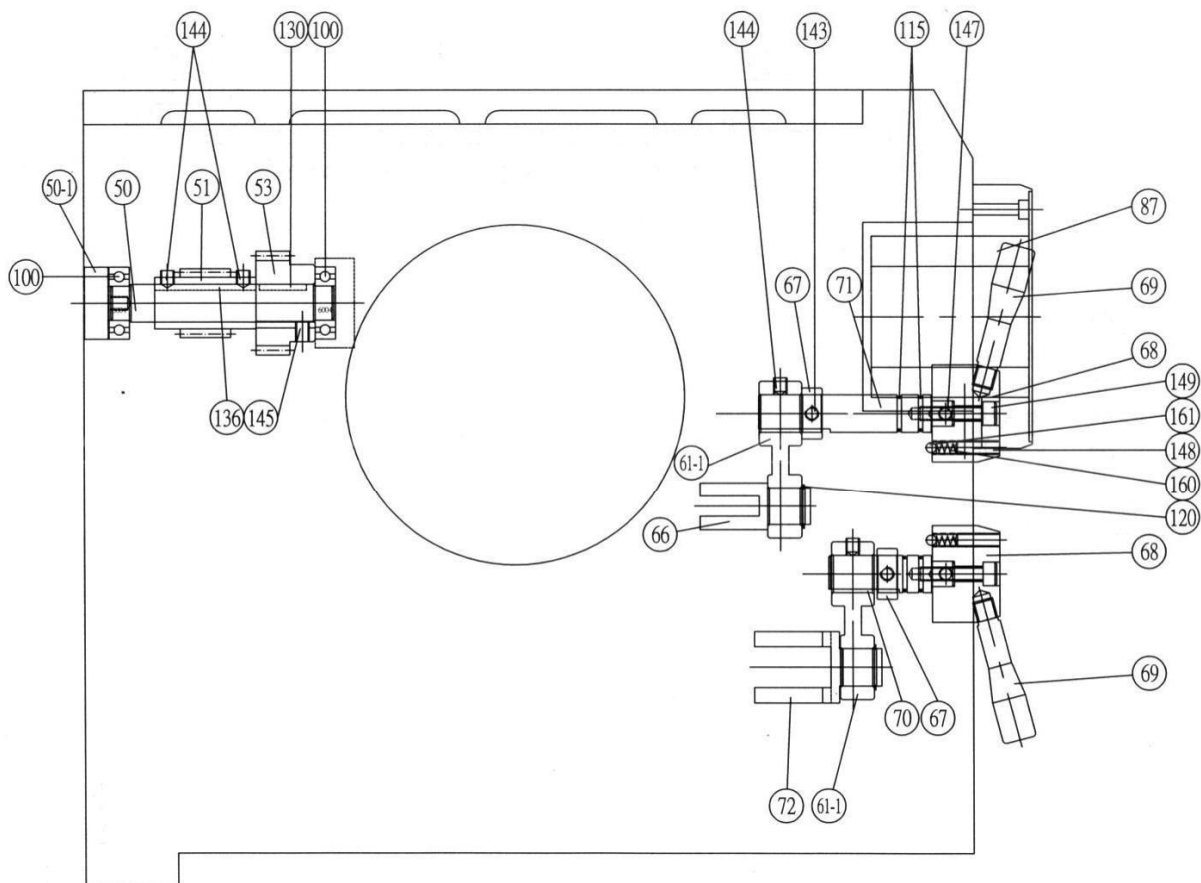

25HC 4"

2010.05.03 Rev.01

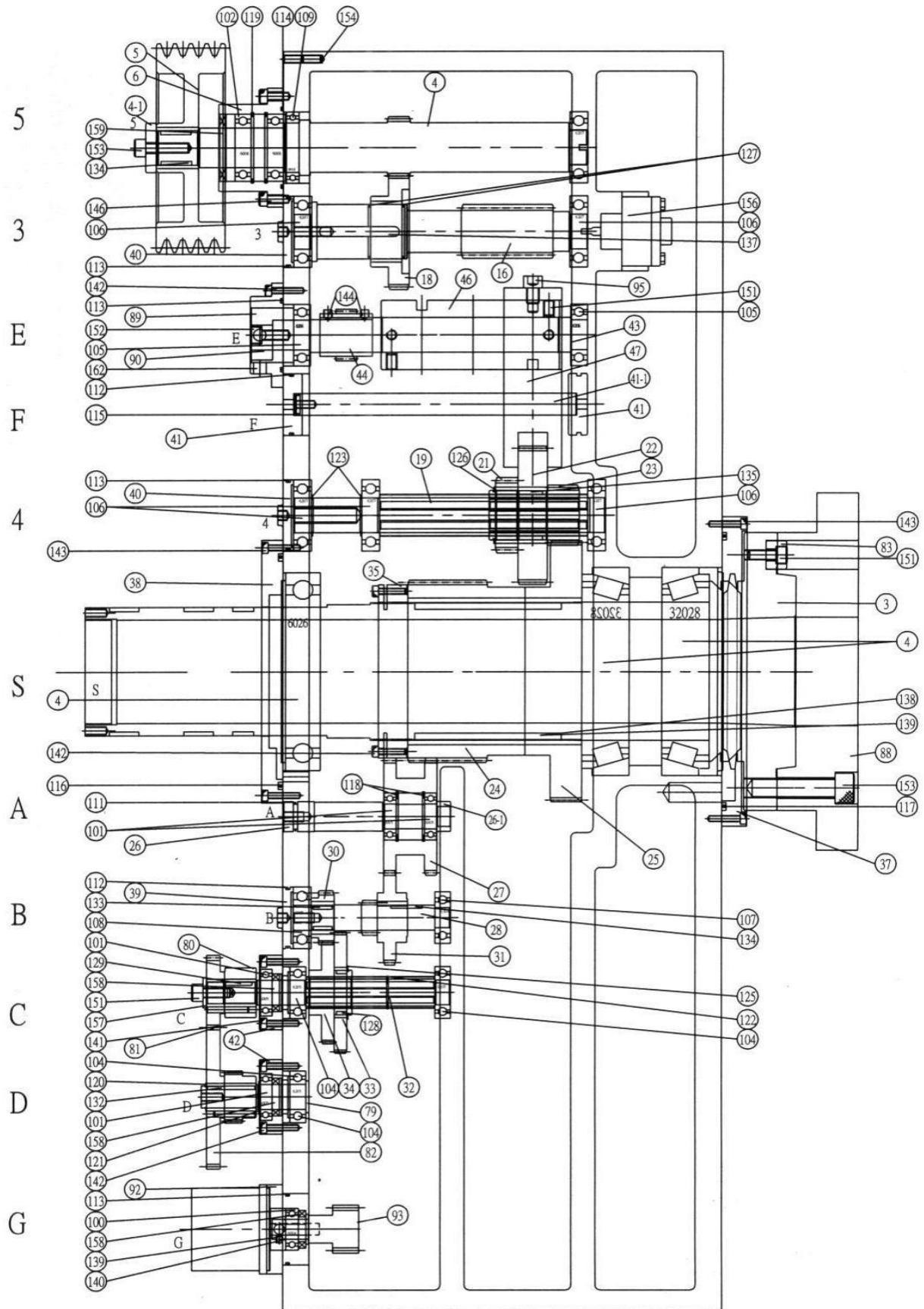

25HC 4"

2010.05.03 Rev.01

## PARTS LIST OF 21/25HC HEADSTOCK\_ SPINDLE BORE 105MM (4") 2010.05.03

| ITEM  | PARTS NO.   | DESCRIPTION | Q'TY | REMARK    |
|-------|-------------|-------------|------|-----------|
| 001   | 21HC-401000 | HEADSTOCK   | 1    | FOR MA-21 |
| 001   | 25HC-401000 | HEADSTOCK   | 1    | FOR MA-25 |
| 002   | 25HA-002000 | COVER       | 1    |           |
| 003D  | 25HA-403000 | SPINDLE     | 1    |           |
| 004   | 18HB-004A10 | SHAFT       | 1    |           |
| 004-1 | 18HA-004100 | SPACER      | 1    |           |
| 005   | 18HA-0051A0 | V-PULLEY    | 1    |           |
| 006   | 18HA-006A00 | COVER       | 1    |           |
| 016   | 18HA-016000 | SHAFT       | 1    |           |
| 018   | 18HA-018000 | GEAR        | 1    |           |
| 019   | 25HA-419000 | SHAFT       | 1    |           |
| 021   | 25HA-421000 | GEAR        | 1    |           |
| 022   | 25HA-422000 | GEAR        | 1    |           |
| 023   | 25HA-423000 | GEAR        | 1    |           |
| 024   | 25HA-424000 | GEAR        | 1    |           |
| 025   | 25HA-425000 | GEAR        | 1    |           |
| 026   | 18HA-026000 | SHAFT       | 1    |           |
| 026-1 | 18HA-026100 | SLEEVE      | 1    |           |
| 027   | 25HA-427000 | GEAR        | 1    |           |
| 028   | 18HA-028000 | SHAFT       | 1    |           |
| 030   | 18HA-030000 | GEAR        | 1    |           |
| 031   | 25HA-431000 | GEAR        | 1    |           |
| 032   | 18HA-032000 | SHAFT       | 1    |           |
| 033   | 18HA-033000 | GEAR        | 1    |           |
| 034   | 18HA-034000 | GEAR        | 1    |           |
| 035   | 25HA-435000 | LOCKING NUT | 1    |           |
| 036   | 25HA-436000 | BUSHING     | 1    |           |
| 037   | 25HA-437000 | COVER       | 1    |           |
| 038   | 25HA-438000 | COVER       | 1    |           |
| 039   | 18HA-039000 | COVER       | 1    |           |
| 040   | 18HA-040000 | COVER       | 2    |           |
| 041   | 18HA-041000 | COVER       | 2    |           |
| 041-1 | 18HA-041100 | SHAFT       | 1    |           |
| 042   | 18HA-042000 | COVER       | 2    |           |

| PARTS LIST OF 21/25HC HEADSTOCK_ SPINDLE BORE 105MM (4") 2010.05.03 |             |                         |      |        |
|---|-------------|-------------------------|------|--------|
| ITEM  | PARTS NO.   | DESCRIPTION             | Q'TY | REMARK |
| 043   | 18HB-017000 | CAM SHAFT               | 1    |        |
| 044   | 18HB-021000 | GEAR                    | 1    |        |
| 046   | 25HB-422000 | CAM                     | 1    |        |
| 047   | 25HB-423000 | SPEED CHANGE FORK       | 1    |        |
| 050   | 25HB-424000 | SHAFT                   | 1    |        |
| 050-1   | 18HB-024100 | STUFF                   | 2    |        |
| 051   | 18HB-025000 | WORM GEAR               | 1    |        |
| 053   | 18HB-026000 | GEAR                    | 1    |        |
| 061-1   | 18HA-061100 | HANDLE FOR SPEED CHANGE | 2    |        |
| 066   | 18HA-066000 | SPEED CHANGE FORK       | 1    |        |
| 067   | 18HA-067000 | RING FOR SPEED CHANGE   | 2    |        |
| 068   | 18HA-068000 | LEVER BASE              | 2    |        |
| 069   | 18HA-069000 | HANDLE FOR SPEED CHANGE | 4    |        |
| 070   | 25HA-470000 | SHAFT FOR SPEED CHANGE  | 1    |        |
| 071   | 25HA-471000 | SHAFT FOR SPEED CHANGE  | 1    |        |
| 072   | 18HA-072000 | SPEED CHANGE FORK       | 1    |        |
| 079   | 18HA-079000 | SHAFT                   | 1    |        |
| 080   | 18HA-080000 | BASE FOR SAFE BOLT      | 1    |        |
| 081   | 18HA-081000 | GEAR                    | 1    |        |
| 082   | 25HA-082000 | GEAR                    | 1    |        |
| 083   | 25HA-483000 | FIXED BLOCK             | 1    |        |
| 087   | 18HC-035000 | BASE OF RATEMETER       | 1    |        |
| 088   |             | CONNECTING PLATE        | 1    |        |
| 089   | 18HB-020000 | BASE OF INSPECTION      | 1    |        |
| 090   | 18HB-019000 | BLOCK OF INSPECTION     | 1    |        |
| 091   | 18HB-015000 | COVER                   | 1    |        |
| 092   | 18HB-028001 | MOTOR COVER             | 1    |        |
| 093   | 18HB-027003 | WORM SHAFT              | 1    |        |
| 095   | 18HB-048000 | SCREW                   | 1    |        |
| 096   | 18HA-085000 | COVER                   | 1    |        |
| 100   |             | BEARING 6004            | 3    |        |
| 101   |             | BEARING 6005            | 4    |        |
| 102   |             | BEARING 6008            | 2    |        |
| 103   |             | BEARING 6026            | 1    |        |
| 104   |             | BEARING 6205            | 3    |        |

| PARTS LIST OF 21/25HC HEADSTOCK_ SPINDLE BORE 105MM (4") 2010.05.03 |           |                              |      |        |
|---|-----------|------------------------------|------|--------|
| ITEM  | PARTS NO. | DESCRIPTION                  | Q'TY | REMARK |
| 105   |           | BEARING 6206                 | 2    |        |
| 106   |           | BEARING 6207                 | 6    |        |
| 107   |           | BEARING 6304                 | 1    |        |
| 108   |           | BEARING 6305                 | 1    |        |
| 109   |           | BEARING 6910                 | 1    |        |
| 110   |           | TAPERED ROLLER BEARING 32028 | 2    |        |
| 111   |           | O RING G25                   | 1    |        |
| 112   |           | O RING G55                   | 2    |        |
| 113   |           | O RING G65                   | 4    |        |
| 114   |           | O RING G75                   | 1    |        |
| 115   |           | O RING P18                   | 5    |        |
| 116   |           | O RING P220                  | 1    |        |
| 117   |           | O RING P265                  | 1    |        |
| 118   |           | C LOCKER R47                 | 2    |        |
| 119   |           | C LOCKER R68                 | 2    |        |
| 120   |           | C LOCKER S22                 | 3    |        |
| 121   |           | C LOCKER S25                 | 1    |        |
| 122   |           | C LOCKER S32                 | 1    |        |
| 123   |           | C LOCKER S35                 | 2    |        |
| 125   |           | C LOCKER S45                 | 1    |        |
| 126   |           | C LOCKER S50                 | 1    |        |
| 127   |           | C LOCKER S55                 | 2    |        |
| 128   |           | KEY 6*6*10                   | 2    |        |
| 129   |           | KEY 6*6*25                   | 1    |        |
| 130   |           | KEY 6*6*28                   | 1    |        |
| 131   |           | KEY 6*6*32                   | 1    |        |
| 132   |           | KEY 6*6*45                   | 1    |        |
| 133   |           | KEY 8*7*18                   | 2    |        |
| 134   |           | KEY 8*7*28                   | 3    |        |
| 135   |           | KEY 8*7*45                   | 2    |        |
| 136   |           | KEY 8*7*56                   | 1    |        |
| 137   |           | KEY 10*8*22                  | 2    |        |
| 138   |           | KEY 18*11*60                 | 2    |        |
| 139   |           | KEY 18*11*80                 | 2    |        |
| 140   |           | C LOCKER S20                 | 1    |        |

| PARTS LIST OF 21/25HC HEADSTOCK_ SPINDLE BORE 105MM (4") 2010.05.03 |           |                    |      |        |
|---|-----------|--------------------|------|--------|
| ITEM  | PARTS NO. | DESCRIPTION        | Q'TY | REMARK |
| 141   |           | SCREW M6*15        | 2    |        |
| 142   |           | SCREW M6*25        | 8    |        |
| 143   |           | SCREW M6*30        | 25   |        |
| 144   |           | SCREW M8*4         | 2    |        |
| 145   |           | SCREW M8*8         | 6    |        |
| 146   |           | SCREW M8*12        | 1    |        |
| 147   |           | SCREW M8*20        | 4    |        |
| 148   |           | SCREW M8*21.55     | 2    |        |
| 149   |           | SCREW M8*25        | 2    |        |
| 150   |           | SCREW M8*30        | 2    |        |
| 151   |           | SCREW M10*14       | 4    |        |
| 152   |           | SCREW M10*25       | 13   |        |
| 153   |           | SCREW M10*40       | 1    |        |
| 154   |           | SCREW M20*80       | 11   |        |
| 155   |           | SCREW M8*14        | 2    |        |
| 140   |           | C LOCKER S20       | 1    |        |
| 156   |           | Oil Pump           | 1    |        |
| 157   |           | SPACER $\phi$ 30*3 | 1    |        |
| 158   |           | OIL SEAL 38*25*7   | 3    |        |
| 159   |           | OIL SEAL 68*40*7   | 1    |        |
| 160   |           | SPRING             | 2    |        |
| 161   |           | BALL               | 2    |        |
| 162   |           | SENSOR             | 3    |        |

# HEADSTOCK \_ 25 HC, SPINDLE BORE 155MM (6'')

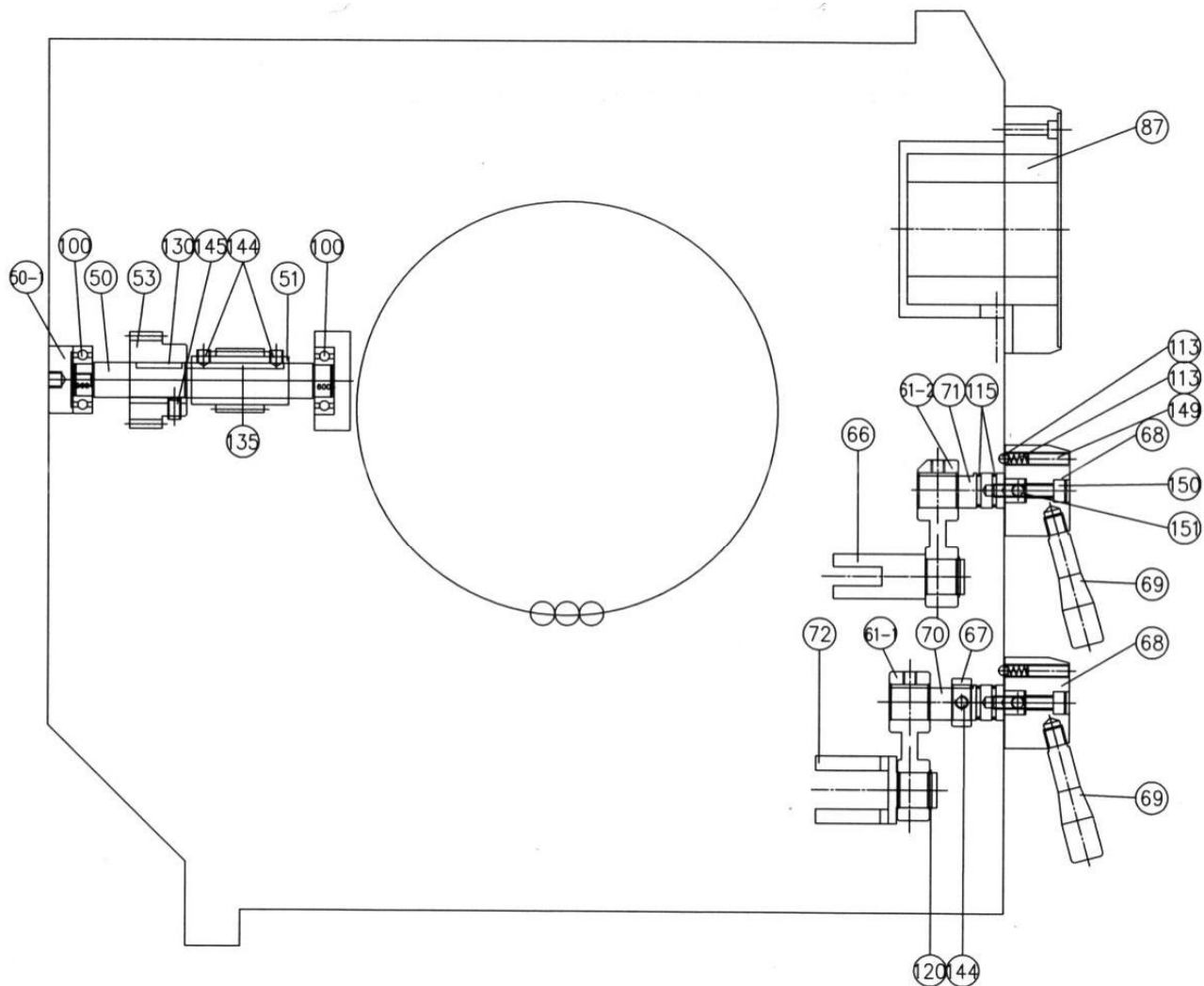

25HC 6''



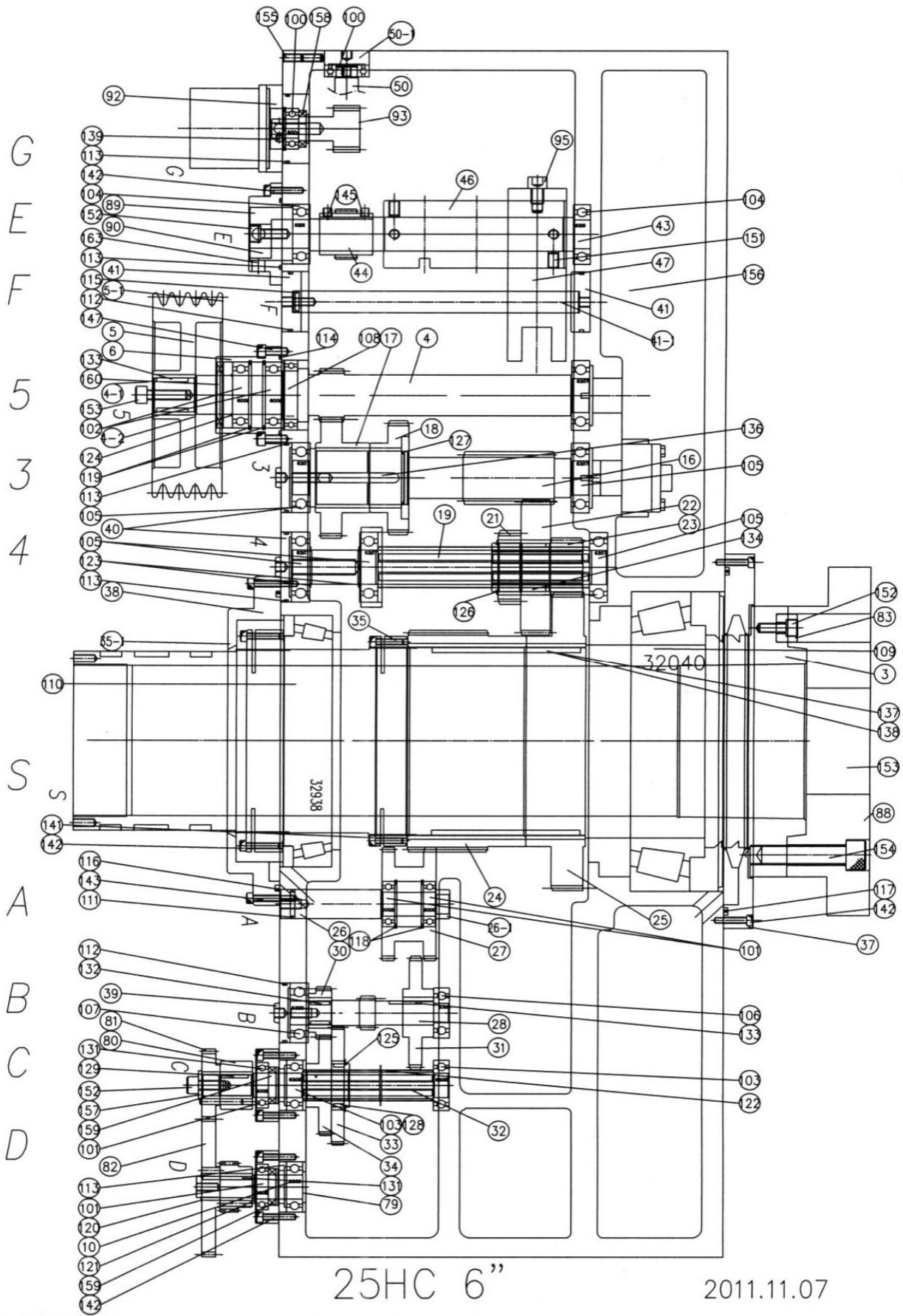

## PARTS LIST OF 25HC HEADSTOCK\_ SPINDLE BORE 155MM (6'') 2011.11.07

| ITEM  | PARTS NO.   | DESCRIPTION        | Q'TY | REMARK |
|-------|-------------|--------------------|------|--------|
| 001   | 25HC-601000 | HEADSTOCK          | 1    |        |
| 002   | 25HA-602000 | COVER              | 1    |        |
| 003   | 25HA-603000 | SPINDLE            | 1    |        |
| 004   | 25HC-604000 | SHAFT              | 1    |        |
| 004-1 | 18HB-004100 | SPACER             | 1    |        |
| 005   | 18HA-0051A0 | V-PULLEY           | 1    |        |
| 006   | 18HA-006000 | COVER              | 1    |        |
| 016   | 18HA-016000 | SHAFT              | 1    |        |
| 017   | 25HC-617000 | GEAR               | 1    |        |
| 018   | 18HA-018000 | GEAR               | 1    |        |
| 019   | 25HA-419000 | SHAFT              | 1    |        |
| 021   | 25HA-421000 | GEAR               | 1    |        |
| 022   | 25HA-422000 | GEAR               | 1    |        |
| 023   | 25HA-423000 | GEAR               | 1    |        |
| 024   | 25HA-624000 | GEAR               | 1    |        |
| 025   | 25HA-625000 | GEAR               | 1    |        |
| 026   | 18HA-026000 | SHAFT              | 1    |        |
| 026-1 | 18HA-026100 | SLEEVE             | 1    |        |
| 027   | 25HA-427000 | GEAR               | 1    |        |
| 028   | 18HA-028000 | SHAFT              | 1    |        |
| 030   | 18HA-030000 | GEAR               | 1    |        |
| 031   | 25HA-631000 | GEAR               | 1    |        |
| 032   | 18HA-032000 | SHAFT              | 1    |        |
| 033   | 18HA-033000 | GEAR               | 1    |        |
| 034   | 18HA-034000 | GEAR               | 1    |        |
| 035   | 25HA-635000 | MASTER NUT - FRONT | 1    |        |
| 035-1 | 25HA-635100 | MASTER NUT - REAR  | 1    |        |
| 037   | 25HA-637000 | COVER              | 1    |        |
| 038   | 25HA-638000 | COVER              | 1    |        |
| 039   | 18HA-039000 | COVER              | 1    |        |
| 040   | 18HA-040000 | COVER              | 2    |        |
| 041   | 18HA-041000 | COVER              | 2    |        |
| 041-1 | 18HA-041100 | SHAFT              | 1    |        |
| 042   | 18HA-042000 | COVER              | 2    |        |

| PARTS LIST OF 25HC HEADSTOCK_ SPINDLE BORE 155MM (6'') 2011.11.07 |             |                         |      |        |
|---|-------------|-------------------------|------|--------|
| ITEM  | PARTS NO.   | DESCRIPTION             | Q'TY | REMARK |
| 043   | 18HB-017000 | CAM SHAFT               | 1    |        |
| 044   | 18HB-021000 | GEAR                    | 1    |        |
| 046   | 25HB-422000 | CAM                     | 1    |        |
| 047   | 25HB-423000 | SPEED CHANGE FORK       | 1    |        |
| 050   | 25HB-624000 | SHAFT                   | 1    |        |
| 050-1   | 18HB-024100 | STUFF                   | 2    |        |
| 051   | 18HB-025000 | WORM GEAR               | 1    |        |
| 053   | 18HB-026000 | GEAR                    | 1    |        |
| 061-1   | 18HA-061100 | HANDLE FOR SPEED CHANGE | 2    |        |
| 066   | 25HA-666000 | SPEED CHANGE FORK       | 1    |        |
| 067   | 18HA-067000 | RING FOR SPEED CHANGE   | 1    |        |
| 068   | 18HA-068000 | LEVER BASE              | 2    |        |
| 069   | 18HA-069000 | HANDLE FOR SPEED CHANGE | 2    |        |
| 070   | 18HA-070000 | SHAFT FOR SPEED CHANGE  | 1    |        |
| 071   | 25HA-671000 | SHAFT FOR SPEED CHANGE  | 1    |        |
| 072   | 18HA-072000 | SPEED CHANGE FORK       | 1    |        |
| 077   | 25HA-677000 | SLEEVE                  | 1    |        |
| 079   | 18HA-079000 | SHAFT                   | 1    |        |
| 080   | 18HA-080000 | BASE FOR SAFE BOLT      | 1    |        |
| 081   | 18HA-081000 | GEAR                    | 1    |        |
| 082   | 25HA-082000 | GEAR                    | 1    |        |
| 083   | 25HA-483000 | FIXED BLOCK             | 1    |        |
| 087   | 18HC-035000 | BASE OF RATEMETER       | 1    |        |
| 089   | 18HB-020000 | BASE OF INSPECTION      | 1    |        |
| 090   | 18HB-019000 | BLOCK OF INSPECTION     | 1    |        |
| 091   | 18HB-015000 | COVER                   | 1    |        |
| 092   | 18HB-028001 | MOTOR COVER             | 1    |        |
| 093   | 18HB-027003 | WORM SHAFT              | 1    |        |
| 095   | 18HB-048000 | SCREW                   | 1    |        |
| 096   | 18HB-085000 | COVER                   | 1    |        |
|   |             | CONNECTING PLATE        | 1    |        |
| 100   |             | BEARING 6004            | 3    |        |
| 101   |             | BEARING 6005            | 2    |        |
|   |             | BEARING 6005Z           | 2    |        |
| 102   |             | BEARING 6008            | 2    |        |

| PARTS LIST OF 25HC HEADSTOCK_ SPINDLE BORE 155MM (6'') 2011.11.07 |           |                              |      |        |
|---|-----------|------------------------------|------|--------|
| ITEM  | PARTS NO. | DESCRIPTION                  | Q'TY | REMARK |
| 103   |           | BEARING 6205                 | 3    |        |
| 104   |           | BEARING 6206                 | 2    |        |
| 105   |           | BEARING 6207                 | 6    |        |
| 106   |           | BEARING 6304                 | 1    |        |
| 107   |           | BEARING 6305                 | 1    |        |
| 108   |           | BEARING 6910                 | 1    |        |
| 109   |           | TAPERED ROLLER BEARING 32040 | 1    |        |
| 110   |           | TAPERED ROLLER BEARING 32938 | 1    |        |
| 111   |           | O RING G25                   | 1    |        |
| 112   |           | O RING G55                   | 2    |        |
| 113   |           | O RING G65                   | 4    |        |
| 114   |           | O RING G75                   | 1    |        |
| 115   |           | O RING P18                   | 5    |        |
| 116   |           | O RING P300                  | 1    |        |
| 117   |           | O RING P340                  | 1    |        |
| 118   |           | C LOCKER R47                 | 2    |        |
| 119   |           | C LOCKER R68                 | 2    |        |
| 120   |           | C LOCKER S22                 | 3    |        |
| 121   |           | C LOCKER S25                 | 1    |        |
| 122   |           | C LOCKER S32                 | 1    |        |
| 123   |           | C LOCKER S35                 | 2    |        |
| 124   |           | C LOCKER S40                 | 1    |        |
| 125   |           | C LOCKER S45                 | 1    |        |
| 126   |           | C LOCKER S50                 | 2    |        |
| 127   |           | C LOCKER S55                 | 1    |        |
| 128   |           | KEY 6*6*10                   | 2    |        |
| 129   |           | KEY 6*6*25                   | 1    |        |
| 130   |           | KEY 6*6*28                   | 1    |        |
| 131   |           | KEY 6*6*45                   | 1    |        |
| 132   |           | KEY 8*7*18                   | 2    |        |
| 133   |           | KEY 8*7*28                   | 3    |        |
| 134   |           | KEY 8*7*45                   | 2    |        |
| 135   |           | KEY 8*7*56                   | 1    |        |
| 136   |           | KEY 10*8*70                  | 2    |        |
| 137   |           | KEY 14*9*60                  | 2    |        |

| PARTS LIST OF 25HC HEADSTOCK_ SPINDLE BORE 155MM (6'') 2011.11.07 |           |                    |      |        |
|---|-----------|--------------------|------|--------|
| ITEM  | PARTS NO. | DESCRIPTION        | Q'TY | REMARK |
| 138   |           | KEY 14*9*80        | 2    |        |
| 139   |           | SCREW M6*6         | 1    |        |
| 141   |           | SCREW M6*25        | 2    |        |
| 142   |           | SCREW M6*30        | 20   |        |
| 143   |           | SCREW M6*40        | 8    |        |
| 144   |           | SCREW M8*4         | 2    |        |
| 145   |           | SCREW M8*8         | 6    |        |
| 146   |           | SCREW M8*12        | 1    |        |
| 147   |           | SCREW M8*20        | 4    |        |
| 148   |           | SCREW M8*21.55     | 2    |        |
| 149   |           | SCREW M8*25        | 2    |        |
| 150   |           | SCREW M8*30        | 2    |        |
| 151   |           | SCREW M10*14       | 4    |        |
| 152   |           | SCREW M10*25       | 13   |        |
| 153   |           | SCREW M10*40       | 1    |        |
| 154   |           | SCREW M20*80       | 11   |        |
| 155   |           | SCREW M8*14        | 2    |        |
| 156   |           | Oil Pump           | 1    |        |
| 157   |           | SPACER $\phi$ 30*3 | 1    |        |
| 158   |           | OIL SEAL 38*22*7   | 1    |        |
| 159   |           | OIL SEAL 38*25*7   | 2    |        |
| 160   |           | OIL SEAL 68*40*7   | 1    |        |
| 161   |           | SPRING             | 2    |        |
| 162   |           | BALL               | 2    |        |
| 163   |           | SENSOR             | 3    |        |

## CHANGE GEAR (END GEAR)

SUITABLE FOR E-lathe 21/25 SERIES, SPINDLE BORE 85MM (3")

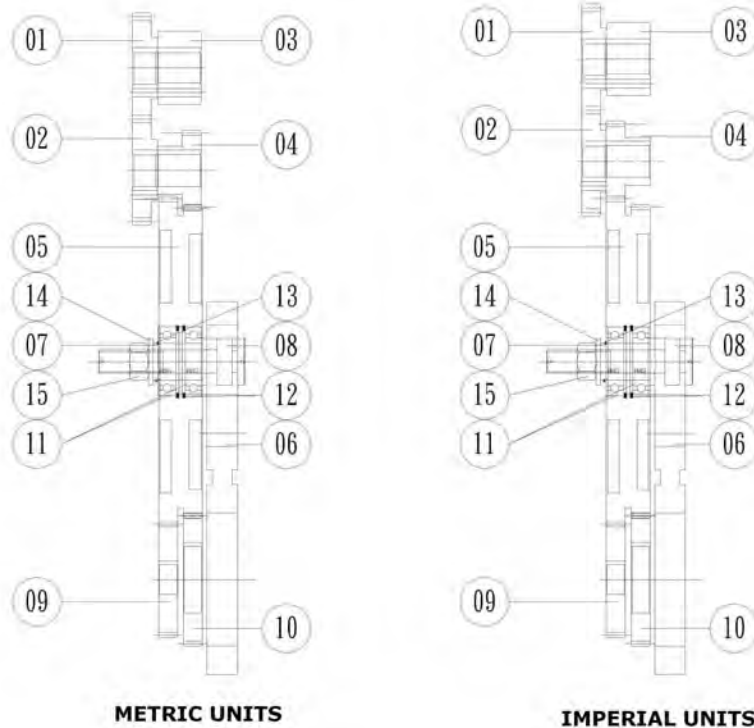

| ITEM | PARTS NO.   | DESCRIPTION  | Q'TY | REMARK |
|------|-------------|--|------|--------|
| 01   | 25HA-081000 | GEAR 42T, M2.5   | 1    |        |
| 02   | 25HA-082000 | GEAR 56T, M2.5   | 1    |        |
| 03   | 18HA-080000 | SAFE PIN BASE  | 1    |        |
| 04   | 16B-031000  | GEAR 28T, M1.75  | 1    |        |
| 05   | 20B-033000  | HAVING TWO LAYERS END GEAR 128T, M1.75<br>HAVING TWO LAYERS END GEAR 120T, M1.75 | 1    |        |
| 06   | 20B-038A00  | BRACKET  | 1    |        |
| 07   | 20B-037000  | SHAFT  | 1    |        |
| 08   | 20B-036000  | SHAFT  | 1    |        |
| 09   | 20B-035000  | END GEAR 42T, M1.75  | 1    |        |
| 10   | 20B-034000  | END GEAR 49T, M1.75  | 1    |        |
| 11   |             | BEARING 6005   | 2    |        |
| 12   |             | C LOCKER R47   | 2    |        |
| 13   |             | C LOCKER S25   | 1    |        |
| 14   |             | SPRING WASHER M16  | 1    |        |
| 15   |             | NUT M16  | 1    |        |

**CHANGE GEAR (END GEAR)**

SUITABLE FOR E-lathe 21/25 SERIES, SPINDLE BORE 105MM (4")

SUITABLE FOR E-lathe 25 SERIES, SPINDLE BORE 155MM (6")

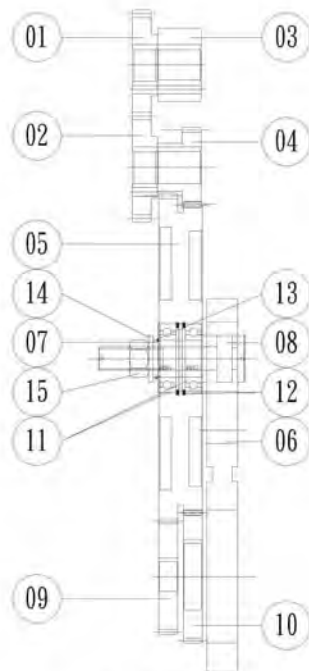

**METRIC UNITS**

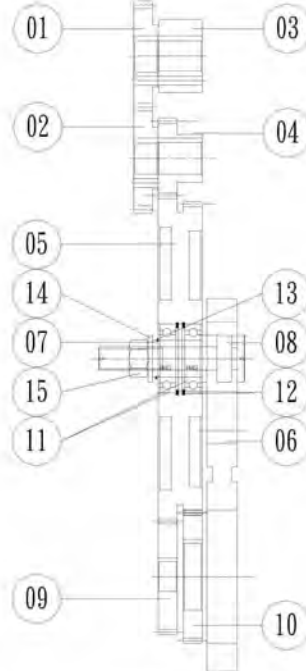

**IMPERIAL UNITS**

| ITEM | PARTS NO.   | DESCRIPTION  | Q'TY | REMARK |
|------|-------------|--|------|--------|
| 01   | 18HA-081000 | GEAR 28T, M2.5   | 1    |        |
| 02   | 25HA-082000 | GEAR 56T, M2.5   | 1    |        |
| 03   | 18HA-080000 | SAFE PIN BASE  | 1    |        |
| 04   | 16B-031000  | GEAR 28T, M1.75  | 1    |        |
| 05   | 20B-033000  | HAVING TWO LAYERS END GEAR 128T, M1.75<br>HAVING TWO LAYERS END GEAR 120T, M1.75 | 1    |        |
| 06   | 20B-038A00  | BRACKET  | 1    |        |
| 07   | 20B-037000  | SHAFT  | 1    |        |
| 08   | 20B-036000  | SHAFT  | 1    |        |
| 09   | 20B-035000  | END GEAR 42T, M1.75  | 1    |        |
| 10   | 20B-034000  | END GEAR 49T, M1.75  | 1    |        |
| 11   |             | BEARING 6005   | 2    |        |
| 12   |             | C LOCKER R47   | 2    |        |
| 13   |             | C LOCKER S25   | 1    |        |
| 14   |             | SPRING WASHER M16  | 1    |        |
| 15   |             | NUT M16  | 1    |        |

# BED - 25B

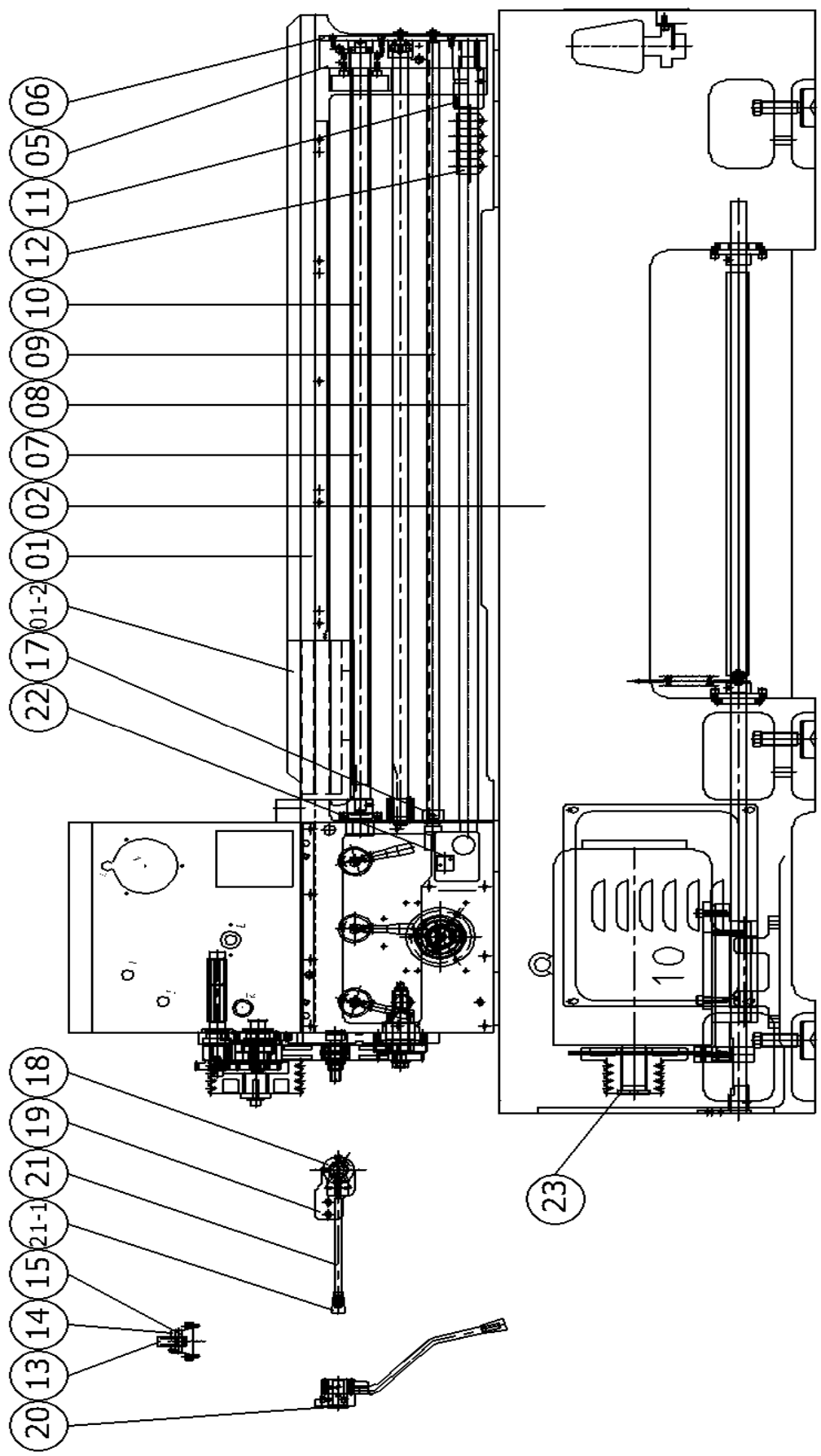



# BED - 25B

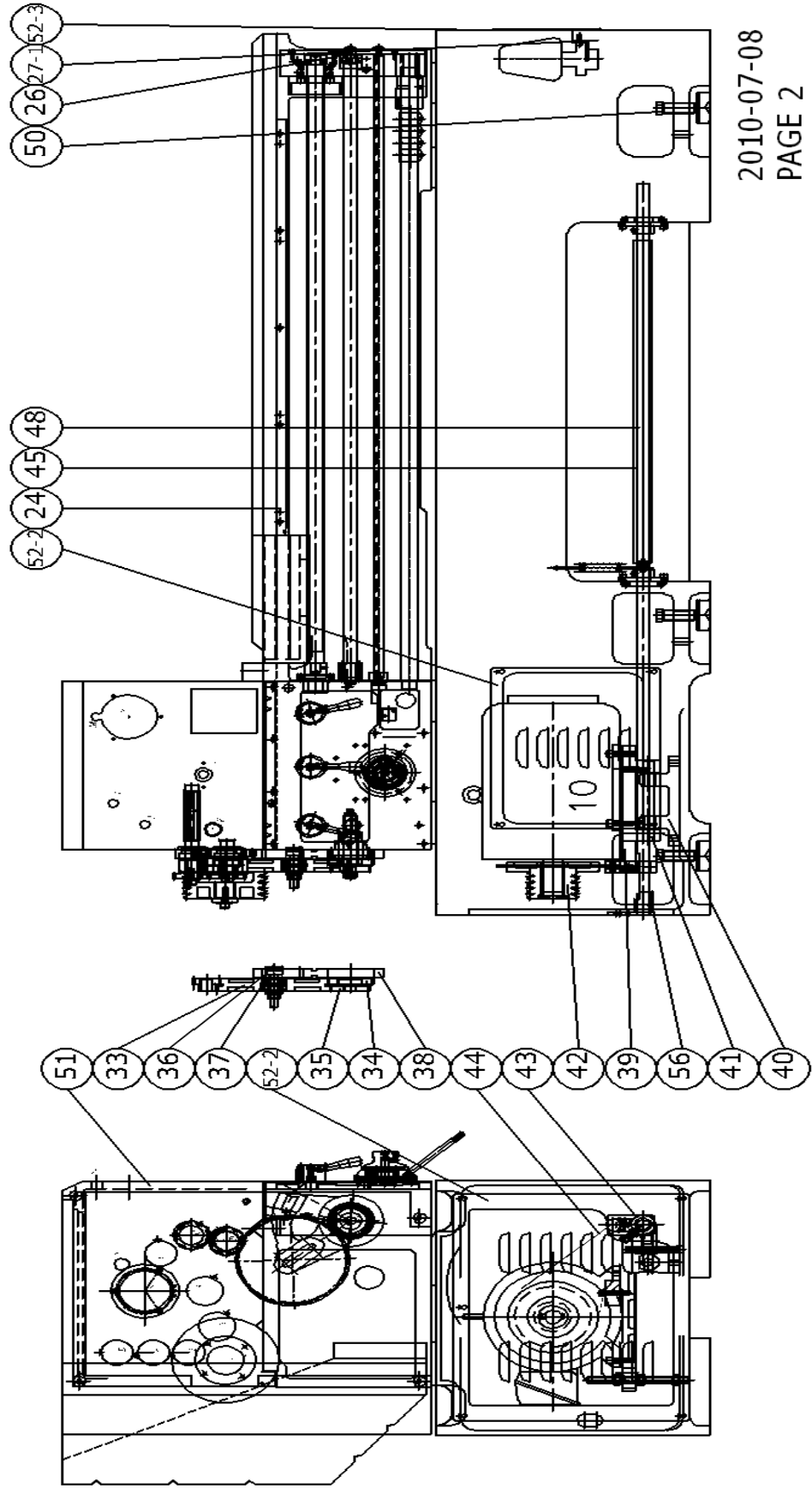

2010-07-08  
PAGE 2

# BED - 25B

2010-07-08  
PAGE 3

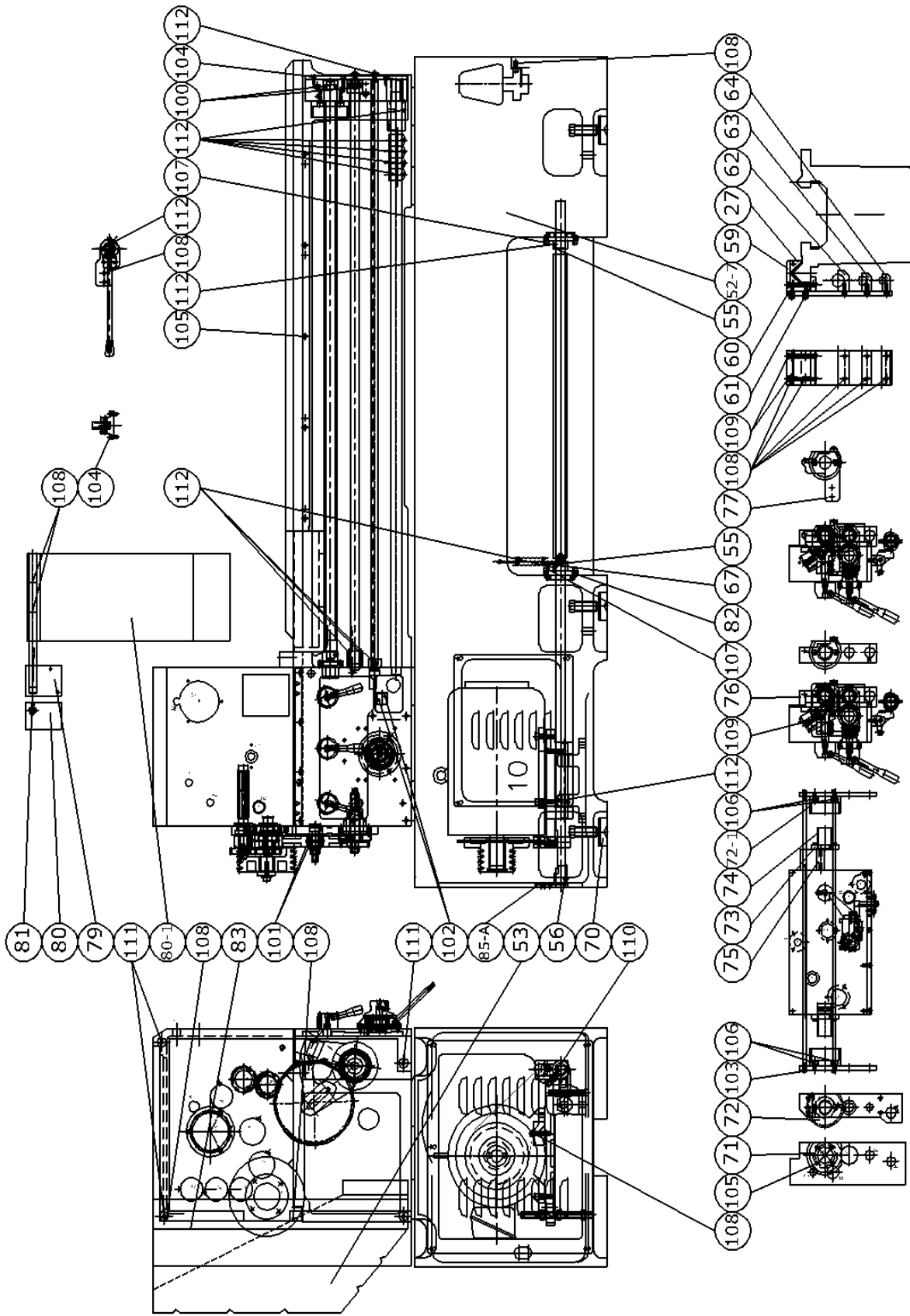

# BED - 25B

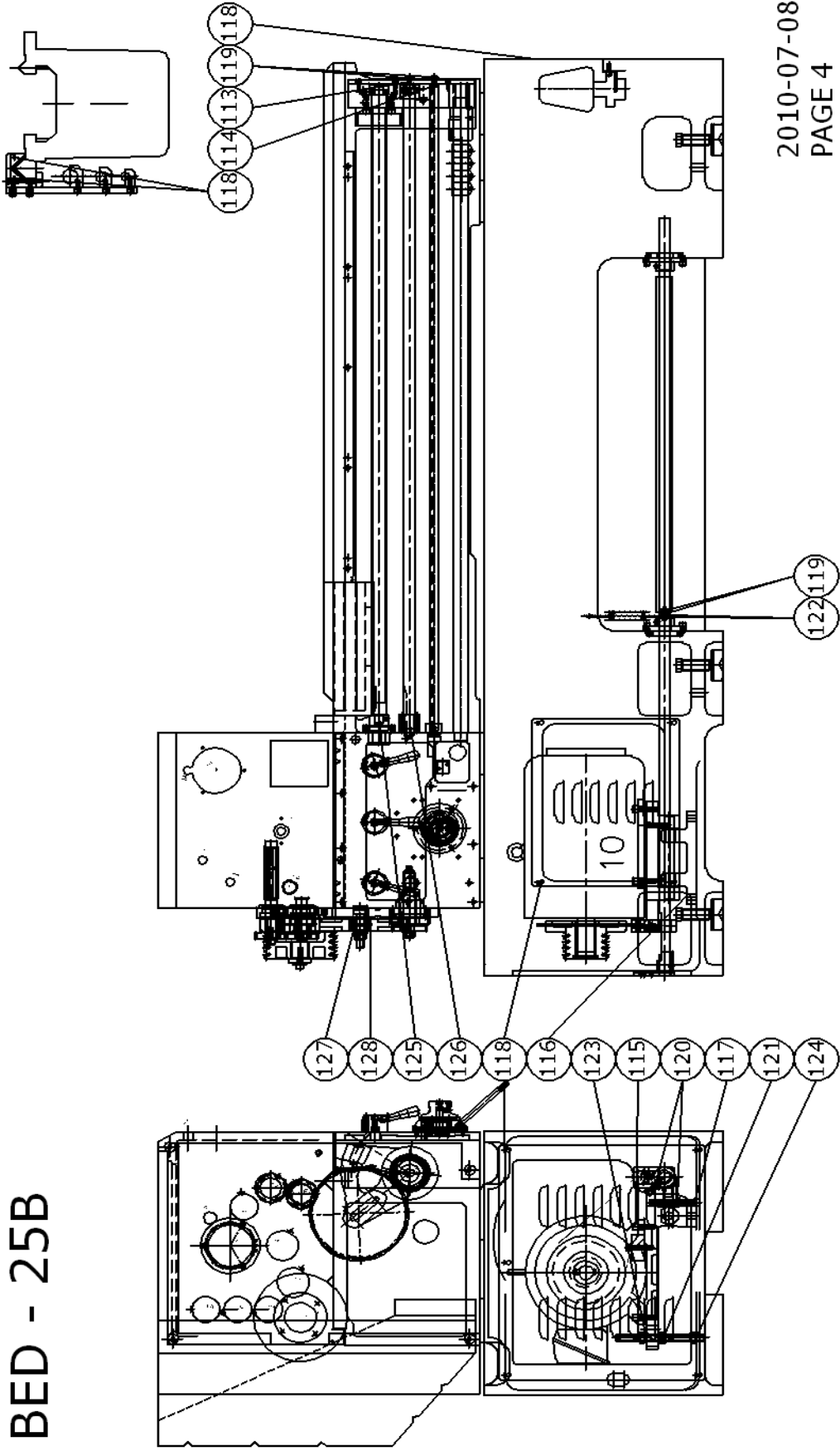

2010-07-08  
PAGE 4

**PART LIST OF BED – 21/25B**

| <b>ITEM</b> | <b>PARTS NO.</b> | <b>DESCRIPTION</b>           | <b>Q'TY</b> | <b>REMARK</b> |
|-------------|------------------|------------------------------|-------------|---------------|
| 001         | 25B-001          | BED                          | 1           | 40/60/80/120  |
| 001-2       | 25B-001-2        | GAP                          | 1           |               |
| 002         | 25B-002          | BED STAND                    | 1           | 40/60/80/120  |
| 005         | 25B-005          | BRACKET OF LEAD SCREW        | 1           |               |
| 006         | 25B-006          | COVER                        | 1           |               |
| 007         | 25B-007          | LEAD SCREW                   | 1           | IN/MM         |
| 008         | 25B-008          | LONGITUDINAL KICK-OUT DEVICE | 1           |               |
| 009         | 25B-009          | SWITCH BAR                   | 1           |               |
| 010         | 25B-010          | FEED BAR                     | 1           |               |
| 011         | 25B-011          | ROTATING SHEATH              | 1           |               |
| 012         | 25B-012          | ECCENTRIC RING               | 4           |               |
| 013         | 25B-013          | VERTICAL ARM                 | 1           |               |
| 014         | 25B-014          | PROP STAND                   | 1           |               |
| 015         | 25B-015          | SHAFT                        | 1           |               |
| 017         | 25B-017          | SWITCH SHORT SHAFT           | 1           |               |
| 018         | 25B-018          | BRACKET                      | 1           |               |
| 019         | 25B-019          | BRACKET                      | 1           |               |
| 020         | 25B-020          | SLEEVE                       | 1           |               |
| 021         | 25B-021          | GRIP                         | 1           |               |
| 021-1       | 25B-021-1        | KNOB                         | 1           |               |
| 022         | 25B-022          | LIMIT SWITCH RACK            | 1           |               |
| 023         | 25B-023          | PAD                          | 1           |               |
| 024         | 25B-024          | RACK                         | 1           |               |
| 026         | 25B-026          | ADJUST SPACER                | 1           |               |
| 027         | 25S-027          | WIPER                        | 2           |               |
| 027-1       | 25B-027-1        | PUMP BRACKET                 | 1           |               |
| 033         | 25B-033          | CHANGE GEAR                  | 1           |               |
| 034         | 25B-034          | GEAR                         | 1           |               |
| 035         | 25B-035          | BEAR                         | 1           |               |
| 036         | 25B-036          | SHAFT                        | 1           |               |
| 037         | 25B-037          | SHAFT                        | 1           |               |
| 038         | 25B-038          | FAN-SHAPED BRACKET           | 1           |               |
| 039         | 25B-039          | MOTOR BASE                   | 1           |               |
| 040         | 25B-040          | SHAFT                        | 1           |               |
| 041         | 25B-041          | BRACKET                      | 1           |               |

| <b>ITEM</b> | <b>PARTS NO.</b> | <b>DESCRIPTION</b> | <b>Q'TY</b> | <b>REMARK</b> |
|-------------|------------------|--------------------|-------------|---------------|
| 042         | 25B-042          | MOTOR PULLEY       | 1           |               |
| 043         | 25B-043          | BRAKE ARM          | 1           |               |
| 044         | 25B-044          | BRAKE BAND         | 1           |               |
| 045         | 25B-045          | BRAKE FOOTREST     | 1           |               |
| 046         | 25B-046          | ADJUST SCREW       | 2           |               |
| 048         | 25B-048          | BRAKE BAR          | 1           |               |
| 050         | 25B-050          | BASIC SCREW        | 6           |               |
| 051         | 25B-051          | COVER              | 1           |               |
| 052-1       | 25B-052-1        | SPEAR PLATE        | 1           |               |
| 052-2       | 25B-052-2        | SPEAR PLATE        | 1           |               |
| 052-3       | 25B-052-3        | SPEAR PLATE        | 1           |               |
| 052-7       | 25B-052-7        | FILTER SPEAR PLATE | 1           |               |
| 052-8       | 25B-052-8        | SPEAR PLATE        | 1           |               |
| 053         | 25B-053          | SLASH GUARD        | 1           |               |
| 054         | 25B-054          | SUPPORT            | 1           |               |
| 055         | 25B-055          | BRAKE FIXED RING   | 2           |               |
| 056         | 25B-056          | RING               | 1           |               |
| 059         | 25B-059          | CHUNK              | 1           |               |
| 060         | 25B-060          | BOARD              | 1           |               |
| 061         | 25B-061          | BOARD              | 1           |               |
| 062         | 25B-062          | BRACKET            | 1           |               |
| 063         | 25B-063          | BRACKET            | 1           |               |
| 064         | 25B-064          | BRACKET            | 1           |               |
| 067         | 25B-067          | SPRING             | 1           |               |
| 070         | 25B-070          | PAD                | 1           |               |
| 071         | 25B-071          | GUARD SEAT         | 1           |               |
| 072         | 25B-072          | GUARD SEAT         | 1           |               |
| 072-1       | 25B-072-1        | GUARD SEAT         | 2           |               |
| 073         | 25B-073          | BOARD              | 2           |               |
| 074         | 25B-074          | RING               | 2           |               |
| 075         | 25B-075          | SLEEVE             | 1           |               |
| 076         | 25B-076          | BRACKET            | 1           |               |
| 077         | 25B-077          | BRACKET            | 1           |               |
| 079         | 25B-079          | PROP STAND SEAT    | 1           |               |
| 080         | 25B-080          | WIRING BAX         | 1           |               |
| 080-1       | 25B-080-1        | CHUCK GUARD        | 1           |               |

| ITEM | PARTS NO. | DESCRIPTION                        | Q'TY | REMARK         |
|------|-----------|------------------------------------|------|----------------|
| 081  | 25B-081   | SHAFT                              | 1    |                |
| 082  | 25B-082   | RING                               | 2    |                |
| 083  | 25B-083   | INTERVAL PLATE                     | 1    | INVERTER LATHE |
| 85-A | 25B-085-A | SEAT                               | 1    |                |
| 100  |           | BEARING 6004                       | 2    |                |
| 101  |           | BEARING 6005                       | 2    |                |
| 102  |           | CAP SCREW M5*12                    | 2    |                |
| 103  |           | CAP SCREW M5*16                    | 4    |                |
| 104  |           | CAP SCREW M6*16                    | 7    |                |
| 105  |           | CAP SCREW M6*30                    | 9    |                |
| 106  |           | CAP SCREW M8*14                    | 6    |                |
| 107  |           | CAP SCREW M8*16                    | 6    |                |
| 108  |           | CAP SCREW M8*20                    | 22   |                |
| 109  |           | CAP SCREW M8*75                    | 3    |                |
| 110  |           | CAP SCREW M10*30                   | 1    |                |
| 111  |           | CAP SCREW M10*170                  | 4    |                |
| 112  |           | SET SCREW M8*8                     | 13   |                |
| 113  |           | SET SCREW M8*20                    | 1    |                |
| 114  |           | SET SCREW M8*25                    | 1    |                |
| 115  |           | HEX FLANGESCREW M10*30             | 4    |                |
| 116  |           | HEX FLANGESCREW M10*35             | 2    |                |
| 117  |           | HEX FLANGESCREW M10*100            | 1    |                |
| 118  |           | BUTTON HEAD SOCKET CAP SCREW M5*12 | 17   |                |
| 119  |           | NUT M8                             | 4    |                |
| 120  |           | NUT M10                            | 2    |                |
| 121  |           | NUT M16                            | 6    |                |
| 122  |           | SPACER M8                          | 2    |                |
| 123  |           | SPACER M16                         | 8    |                |
| 124  |           | SPRING SPACER M16                  | 2    |                |
| 125  |           | ID TAPER PIN dia.5*45              | 1    |                |
| 126  |           | TAPER PIN dia.5*45                 | 1    |                |
| 127  |           | C LOCKER S25                       | 1    |                |
| 128  |           | C LOCKER R45                       | 1    |                |

# CARRIAGE - 25S

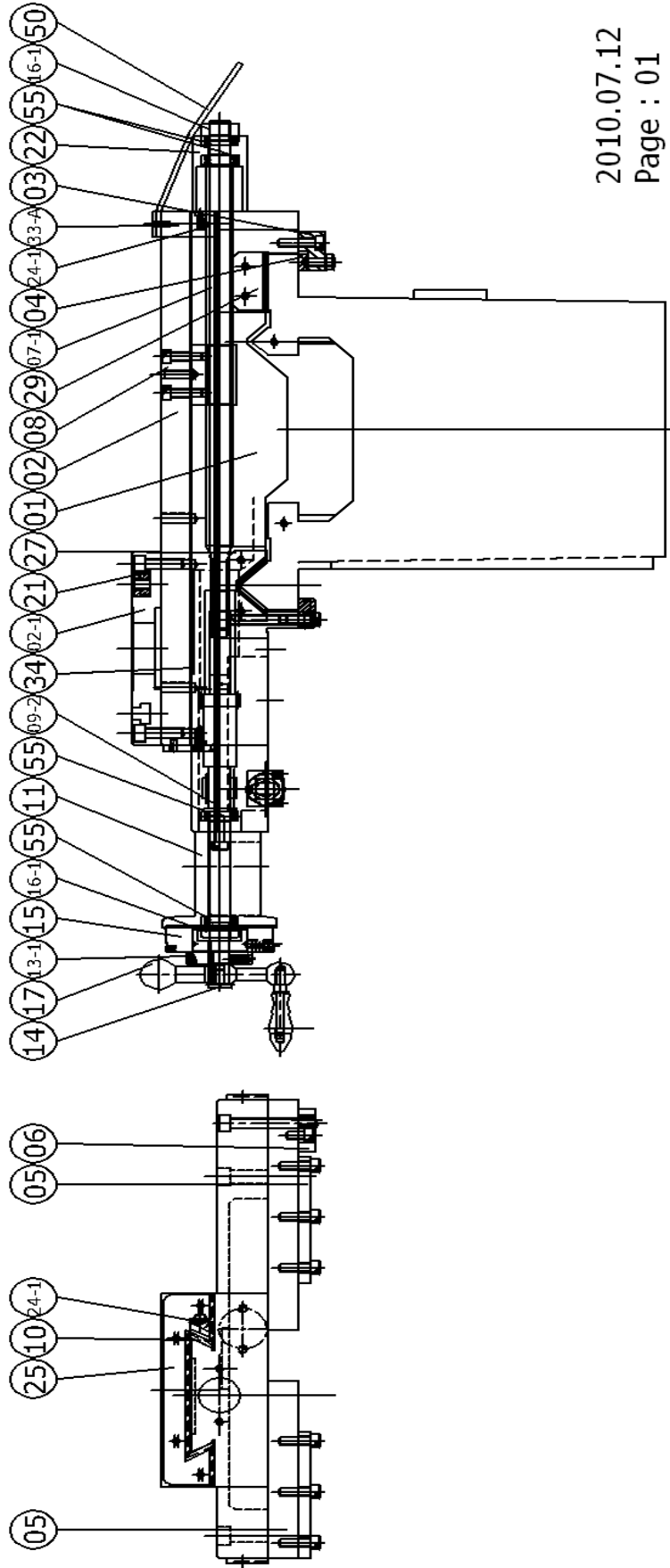

2010.07.12  
Page : 01

# CARRIAGE - 25S

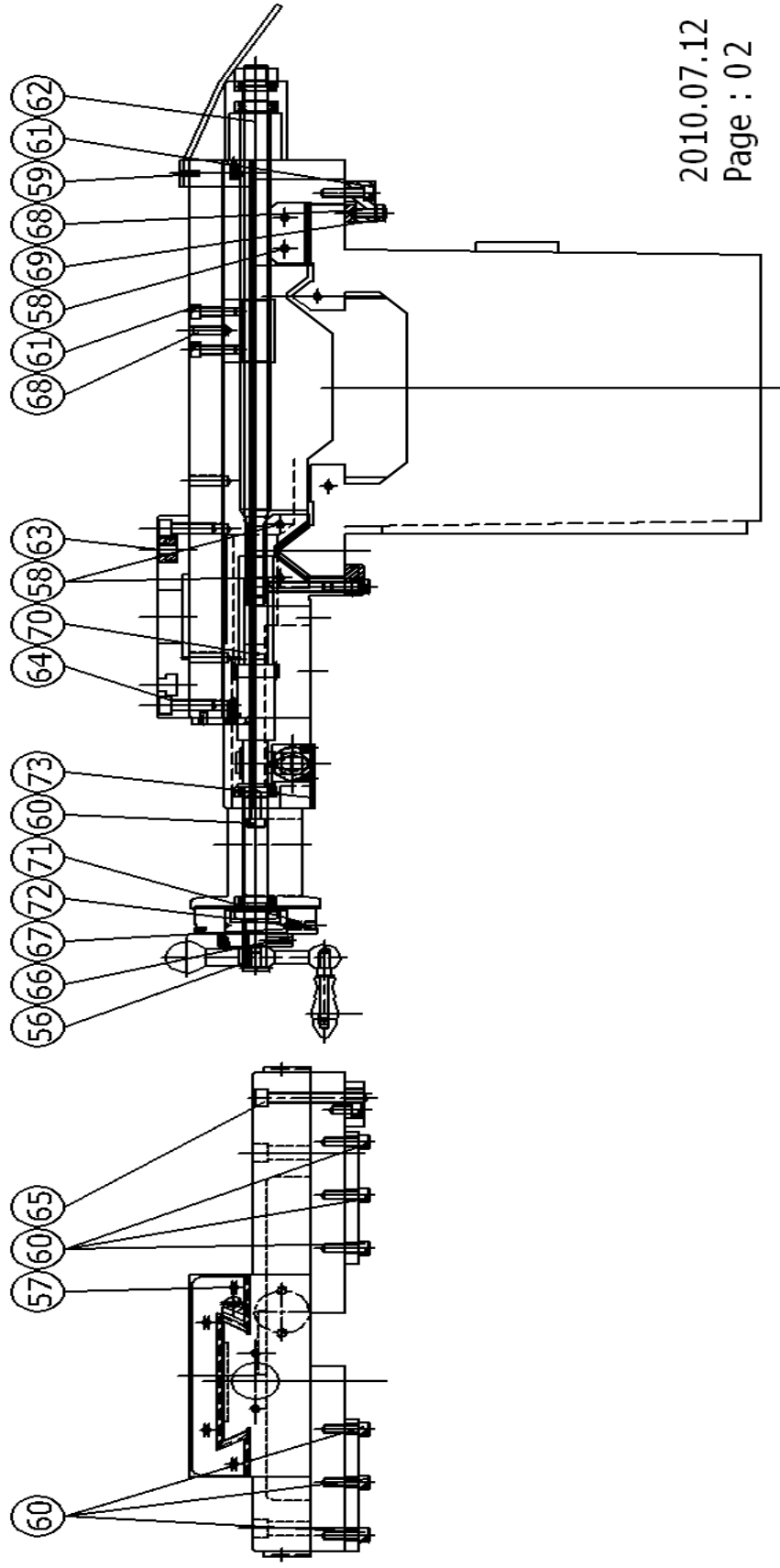

2010.07.12  
Page : 02



| ITEM  | PARTS NO.   | DESCRIPTION             | Q'TY | REMARK              |
|-------|-------------|-------------------------|------|---------------------|
| 001   | 25S-001     | CARRIAGE                | 1    |                     |
| 002   | 25S-002     | CROSS SLIDE             | 1    |                     |
| 002-1 | 25S-002-1   | GRADUATION RING SEAT    | 1    |                     |
| 003   | 25S-003     | PLATE                   | 1    |                     |
| 004   | 25S-004     | ADJUST BOARD - REAR     | 1    |                     |
| 005   | 25S-005     | PLATE                   | 1    |                     |
| 006   | 25S-006     | LOCK PLATE              | 1    |                     |
| 007-1 | 25S-007     | CARRIAGE LEADSCREW      | 1    | mm/ inch            |
| 008   | 25S-008     | NUT                     | 1    | mm/ inch            |
| 009-2 | 25S-009-2   | FEED BAR SHAFT          | 1    |                     |
| 010   | 25S-010     | GIB                     | 1    |                     |
| 011   | 25S-011     | BRACKET                 | 1    |                     |
| 013-1 | 25S-013-1   | GRADUATION RING SLEEVE  | 1    |                     |
| 014   | 25S-014     | SCREW                   | 1    |                     |
| 015   | 25S-015     | GRADUATED COLLAR        | 1    | mm/ inch            |
| 016-1 | 25S-016-1   | HEX. NUT                | 2    |                     |
| 017   | 25S-017018B | SHAFT SET               | 1    |                     |
| 018   | 25S-021     | TOOLPOST NUT            | 3    |                     |
| 024-1 | 25S-024-1   | ADJUST SCREW            | 2    |                     |
| 025   | 25S-025     | WIPER - FOR CROSS SLIDE | 1    |                     |
| 027   | 25S-027     | WIPER - FOR CARRIAGE    | 2    |                     |
| 029   | 25S-029     | WIPER - FOR CARRIAGE    | 2    |                     |
| 033-A | 25S-033-A   | PLATE                   | 1    |                     |
| 034   | 25S-034     | COVER                   | 1    |                     |
| 035   | 25S-035     | SCREW SEAT              | 1    | inverter lathe only |
| 036   | 25S-036     | GEAR                    | 1    | inverter lathe only |
| 038   | 25S-038-1   | TOOLPOST GUARD          | 1    | opt.                |
| 038-A | 25S-038-A   | ACRYLIC                 | 1    | opt.                |
| 039   | 25S-039     | ENCLOSURE               | 1    | inverter lathe only |
| 040   | 25S-040     | RESISTANCE PROP STNAD   | 1    | inverter lathe only |
| 050   | 25S-050     | SPLASH GURAD            | 1    |                     |
| 055   |             | BEAR ING 51103          | 4    |                     |

| ITEM | PARTS NO. | DESCRIPTION                        | Q'TY | REMARK                 |
|------|-----------|------------------------------------|------|------------------------|
| 056  |           | KEY 4*4*28                         | 1    |                        |
| 057  |           | BUTTON HEAD SOCKET CAP SCREW M5*10 | 4    |                        |
| 058  |           | BUTTON HEAD SOCKET CAP SCREW M5*12 | 8    |                        |
| 059  |           | BUTTON HEAD SOCKET CAP SCREW M6*14 | 5    |                        |
| 060  |           | CAP SCREW M8*25                    | 8    |                        |
| 061  |           | CAP SCREW M8*30                    | 8    |                        |
| 062  |           | CAP SCREW M8*70                    | 2    |                        |
| 063  |           | CAP SCREW M8                       | 3    | tie in toolpost height |
| 064  |           | CAP SCREW M10                      | 4    | tie in toolpost height |
| 065  |           | CAP SCREW M70                      | 1    |                        |
| 066  |           | SET SCREW M6*20                    | 1    |                        |
| 067  |           | SET SCREW M8*10                    | 1    |                        |
| 068  |           | SET SCREW M8*25                    | 6    |                        |
| 069  |           | NUT M8                             | 5    |                        |
| 070  |           | PIN                                | 1    |                        |
| 071  |           | SPRING                             | 1    |                        |
| 072  |           | BALL                               | 1    |                        |
| 073  |           | SPACER                             | 1    | inverter lathe only    |
| 073  |           | BEARING TA1725                     | 1    | inverter lathe only    |

# TOOL POST

2010.07.12

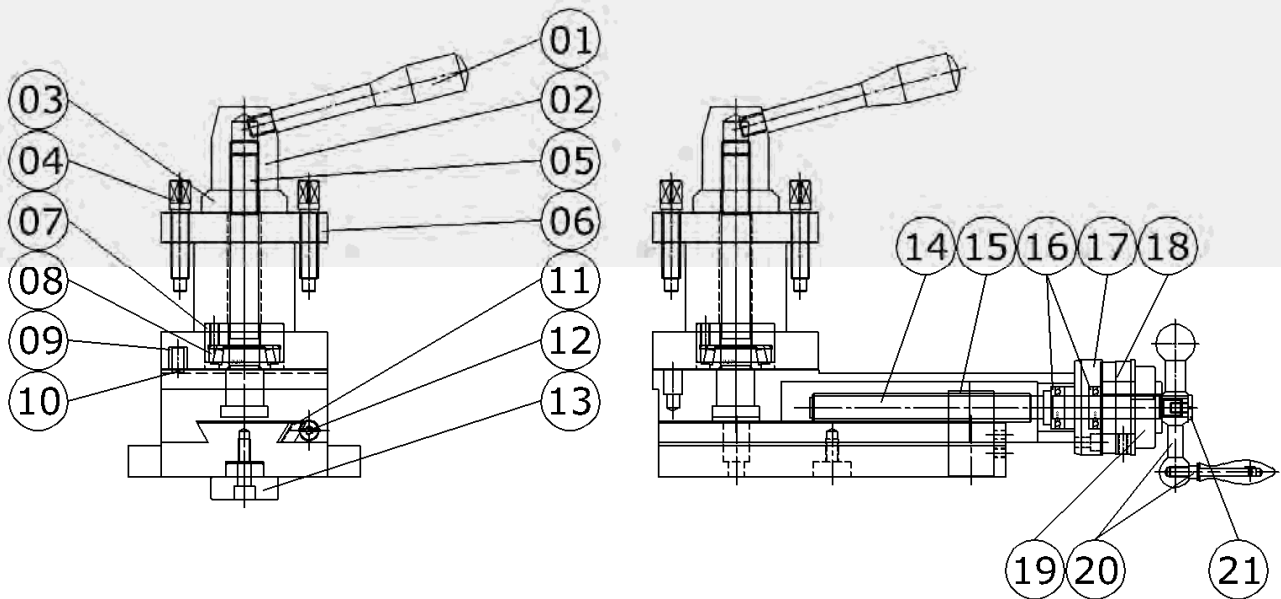

| ITEM | PARTS NO. | DESCRIPTION     | Q'TY | REMARK |
|------|-----------|-----------------|------|--------|
| 001  |           | HANDLE          | 1    |        |
| 002  |           | HANDLE BOSS     | 1    |        |
| 003  |           | WASHER          | 1    |        |
| 004  |           | LOCKING SCREW   | 12   |        |
| 005  |           | SHAFT           | 1    |        |
| 006  |           | TOOL POST       | 1    |        |
| 007  |           | BEARING SEAT    | 1    |        |
| 008  |           | BEARING 30204   | 1    |        |
| 009  |           | SLEEVE          | 1    |        |
| 010  |           | LOCATING PIN    | 1    |        |
| 011  |           | GIB             | 1    |        |
| 012  |           | LOCKING SCREW   | 2    |        |
| 013  |           | BLOCK           | 1    |        |
| 014  |           | LEADSCREW       | 1    |        |
| 015  |           | BLOCK           | 1    |        |
| 016  |           | BEARING 51102   | 2    |        |
| 017  |           | BRACKET         | 1    |        |
| 018  |           | GRADUATION RING | 1    |        |
| 019  |           | HANDLE SEAT     | 1    |        |
| 020  |           | HANDLE SET      | 1    |        |
| 021  |           | LOCKING SCREW   | 1    |        |

APRON - 25A

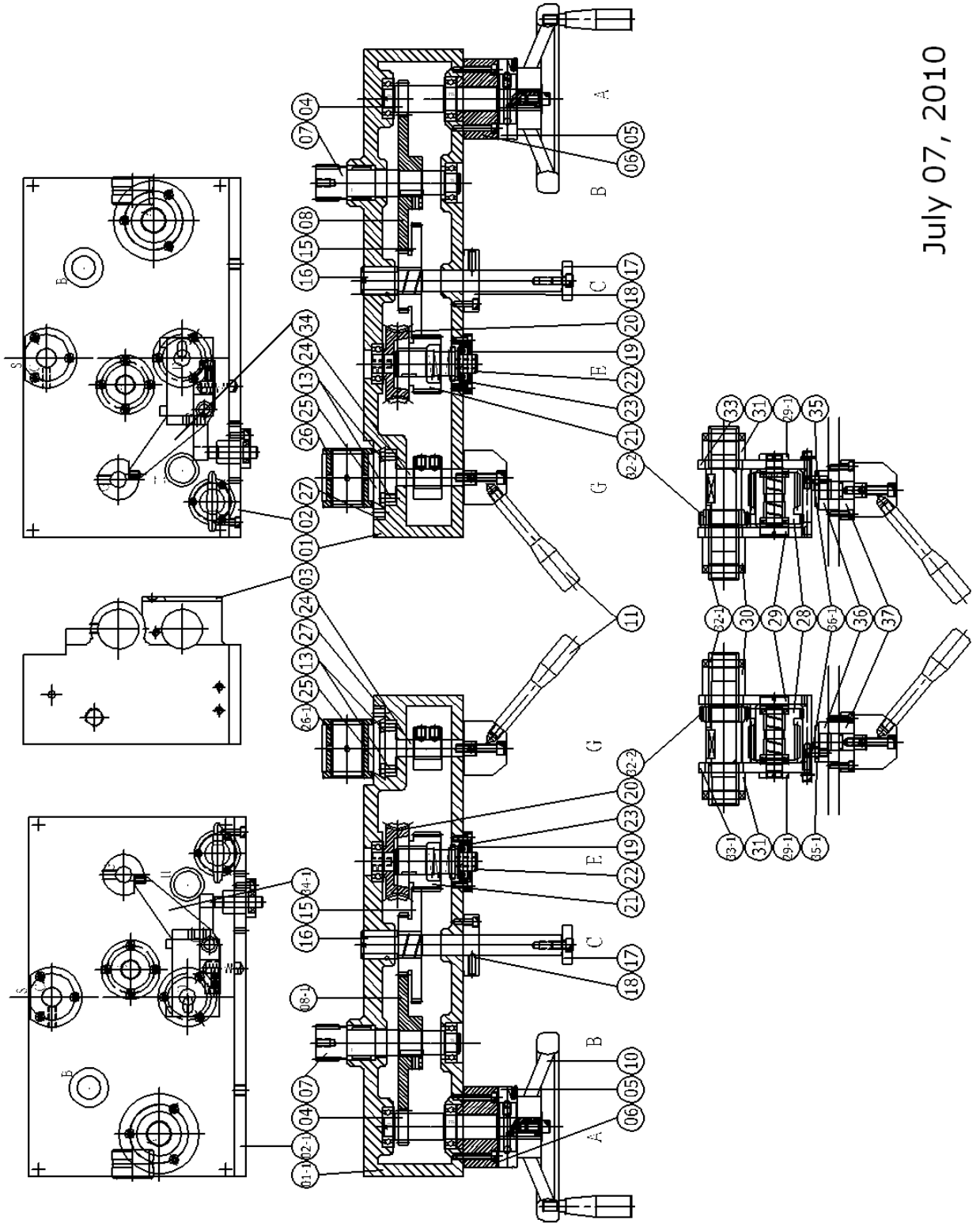

July 07, 2010

APRON - 25A

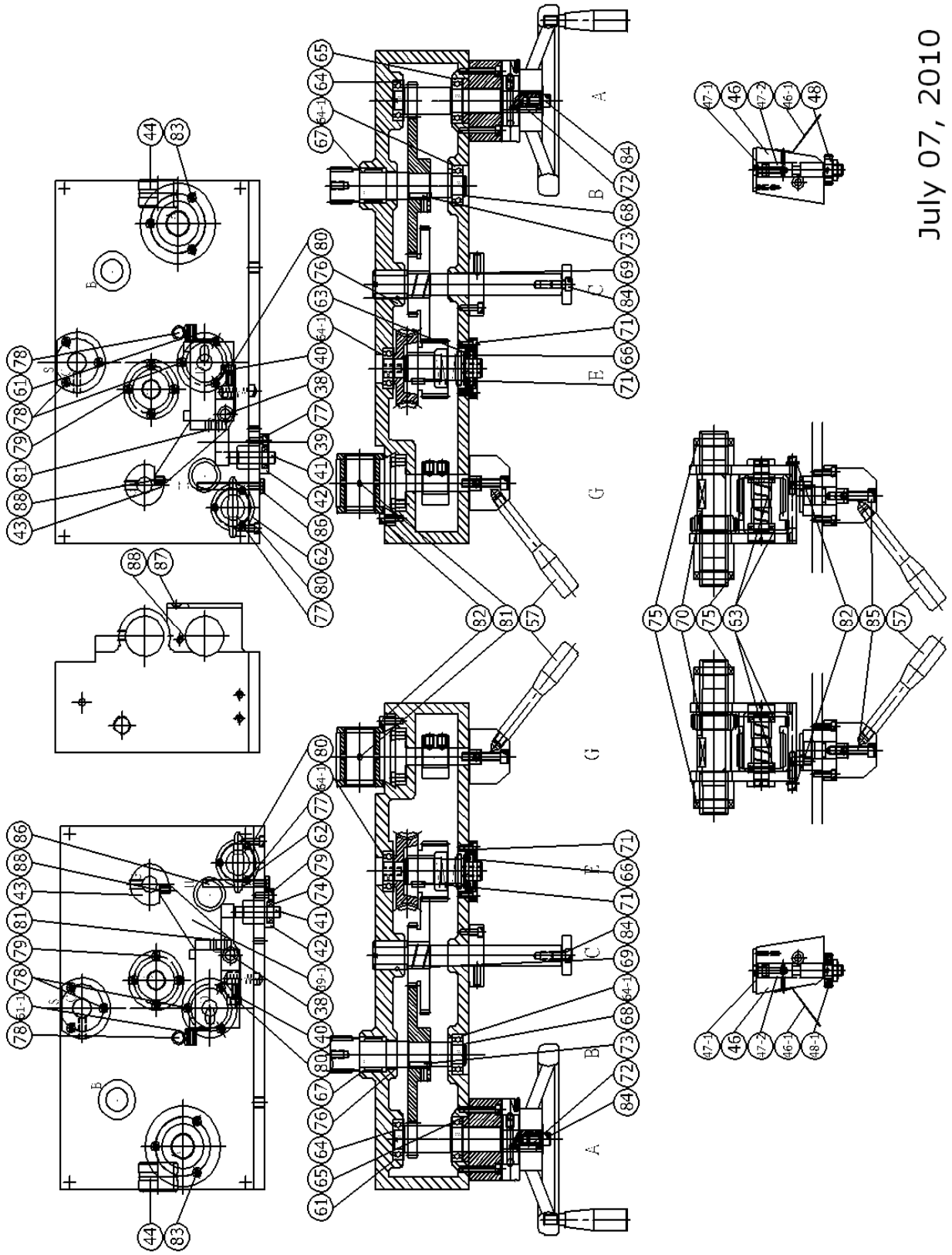

July 07, 2010

APRON - 25A

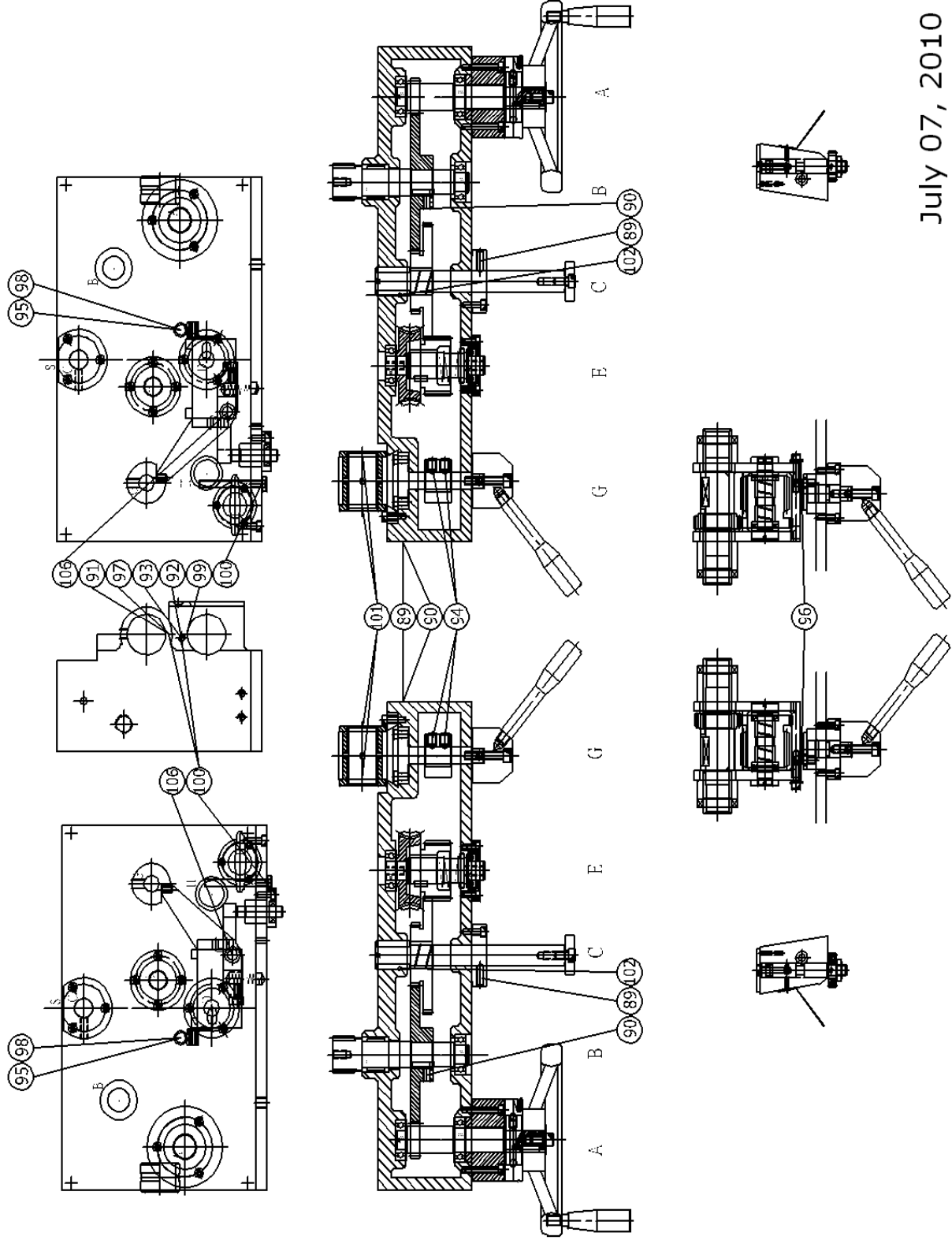

July 07, 2010

**PART LIST OF APRON-21/25A**

| <b>LIST OF 21/25A – APRON</b> |                  |                         |             |               |
|-------------------------------|------------------|-------------------------|-------------|---------------|
| <b>ITEM</b>                   | <b>PARTS NO.</b> | <b>DESCRIPTION</b>      | <b>Q'TY</b> | <b>REMARK</b> |
| 001                           | 25A-001          | APRON BODY - RIGHT HAND | 1           |               |
| 001-1                         | 25A-001          | APRON BODY - LEFT HAND  | 1           |               |
| 002                           | 25A-002          | BASE PLATE - RIGHT HAND | 1           |               |
| 002-1                         | 25A-002          | BASE PLATE - LEFT HAND  | 1           |               |
| 003                           | 25A-003          | COVER                   | 1           |               |
| 004                           | 25A-004          | SHAFT                   | 1           |               |
| 005                           | 25A-005          | GRADUATED COLLAR        | 1           | INCH / MM     |
| 006                           | 25A-006          | HOUSING                 | 1           |               |
| 007                           | 25A-007          | GEAR                    | 1           |               |
| 008                           | 25A-008          | GEAR                    | 1           | INCH / MM     |
| 010                           | 25A-010          | HANDWHEEL               | 1           |               |
| 011                           | 25A-011          | HANDLE GRIP             | 1           |               |
| 013                           | 25A-013          | ROTATING COLUMN         | 1           |               |
| 015                           | 25A-015          | GEAR                    | 1           |               |
| 016                           | 25A-016          | SHAFT                   | 1           |               |
| 017                           | 25A-017          | SHAFT                   | 1           |               |
| 018                           | 25A-018          | COVER                   | 1           |               |
| 019                           | 25A-019          | COVER                   | 1           |               |
| 020                           | 25A-020          | WORM GEAR               | 1           |               |
| 021                           | 25A-021          | GEAR                    | 1           |               |
| 022                           | 25A-022          | SHAFT                   | 1           |               |
| 023                           | 25A-023          | ADJUST PIN              | 1           |               |
| 024                           | 25A-024          | CLOSE SHAFT             | 1           |               |
| 025                           | 25A-025          | HALF-NUT SUPPORT        | 1           |               |
| 026                           | 25A-026          | HALF-NUT                | 1           | INCH / MM     |
| 027                           | 25A-027          | 60° PIN                 | 1           |               |
| 028                           | 25A-028          | WORM GEAR               | 1           |               |
| 029                           | 25A-029          | SHAFT                   | 1           |               |
| 029-1                         | 25S-016          | HEX. NUT                | 1           |               |
| 030                           | 25A-030          | SLEEVE                  | 1           |               |
| 31                            | 25A-031          | SLEEVE                  | 1           |               |
| 032-1                         | 25A-032          | SHAFT                   | 1           |               |
| 032-2                         | 25A-032-2        | GEAR                    | 1           |               |

| ITEM  | PARTS NO.  | DESCRIPTION              | Q'TY | REMARK |
|-------|------------|--------------------------|------|--------|
| 033   | 25A-0330R0 | WORM GEAR SUPPORT- RIGHT | 1    |        |
| 033-1 | 25A-0330L0 | WORM GEAR SUPPORT- LEFT  | 1    |        |
| 034   | 25A-0340R0 | WORM GEAR SUPPORT- RIGHT | 1    |        |
| 034-1 | 25A-0340L0 | WORM GEAR SUPPORT- LEFT  | 1    |        |
| 035   | 25A-0350R0 | CHANG SHAFT - RIGHT      | 1    |        |
| 035-1 | 25A-0350L0 | CHANG SHAFT - LEFT       | 1    |        |
| 036   | 25A-036    | TURN TABLE               | 1    |        |
| 036-1 | 25A-036-1  | BOLT                     | 1    |        |
| 037   | 25A-037    | COVER                    | 1    |        |
| 038   | 25A-038    | SHAFT                    | 1    |        |
| 039   | 25A-0390R0 | ROCKING ARM - RIGHT      | 1    |        |
| 039-1 | 25A-0390L0 | ROCKING ARM - LEFT       | 1    |        |
| 040   | 25A-040    | POSITION CHUNK           | 1    |        |
| 041   | 25A-041    | SHAFT                    | 1    |        |
| 042   | 25A-042    | COVER                    | 1    |        |
| 043   | 25A-043    | COLLAR                   | 1    |        |
| 044   | 25A-044    | RING                     | 1    |        |
| 046   | 25A-046    | INDICATE SEAT            | 1    |        |
| 047-1 | 25A-047-1  | INDICATE DISH            | 1    |        |
| 047-2 | 25A-047-2  | INDICATE SHAFT           | 1    |        |
| 048   | 25A-0480M3 | INDICATE GEAR - MM       | 1    |        |
| 048-1 | 25A-0480I0 | INDICATE GEAR - INCH     | 1    |        |
| 057   | 25A-057    | HANDLE GRIP              | 1    |        |
| 060   | 25A-060    | FEED SPRING              | 1    |        |
| 061   | 25A-0610R0 | SPRING - RIGHT HAND      | 1    |        |
| 061-1 | 25A-0610L0 | SPRING - LEFT HAND       | 1    |        |
| 062   | 25A-062    | PUMP                     | 1    |        |
| 063   |            | BEARING 51103            | 2    |        |
| 064   |            | BEARING 6004             | 1    |        |
| 064-1 |            | BEARING 6004ZZ           | 2    |        |
| 065   |            | BEARING 6005ZZ           | 1    |        |
| 066   |            | BEARING 51104            | 1    |        |
| 067   |            | BEARING TA-2830          | 1    |        |
| 068   |            | C-RING S20               | 1    |        |
| 069   |            | C-RING S22               | 1    |        |
| 070   |            | KEY 5*5*20               | 1    |        |



| ITEM | PARTS NO. | DESCRIPTION                  | Q'TY | REMARK |
|------|-----------|------------------------------|------|--------|
| 071  |           | KEY 6*6*14                   | 1    |        |
| 072  |           | KEY 6*6*20                   | 1    |        |
| 073  |           | KEY 7*7*20                   | 1    |        |
| 074  |           | OIL SEAL 12*22*7             | 1    |        |
| 075  |           | OIL SEAL 32*45*8             | 1    |        |
| 076  |           | O-RING P14                   | 1    |        |
| 077  |           | CAP SCREW M5*10)             | 3    |        |
| 078  |           | CAP SCREW M5*20)             | 7    |        |
| 079  |           | CAP SCREW M6*10)             | 7    |        |
| 080  |           | CAP SCREW M6*16)             | 9    |        |
| 081  |           | CAP SCREW M6*20)             | 4    |        |
| 082  |           | CAP SCREW M6*25)             | 4    |        |
| 083  |           | CAP SCREW M6*45)             | 1    |        |
| 084  |           | CAP SCREW M8*14)             | 2    |        |
| 085  |           | CAP SCREW M8*30)             | 2    |        |
| 086  |           | HEX. FLANGE SCREW M8*70)     | 1    |        |
| 087  |           | ANS SCREW M6*16              | 5    |        |
| 088  |           | SET SCREW M6*6               | 2    |        |
| 089  |           | SET SCREW M8*8               | 2    |        |
| 090  |           | SET SCREW M8*16              | 3    |        |
| 091  |           | SET SCREW M8*20              | 2    |        |
| 092  |           | SET SCREW M8*40              | 1    |        |
| 093  |           | SET SCREW M8*50              | 1    |        |
| 094  |           | SET SCREW M10*16             | 2    |        |
| 095  |           | SPACER M5                    | 1    |        |
| 096  |           | SPACER M6                    | 1    |        |
| 097  |           | THICKNESS SPACER M6          | 1    |        |
| 098  |           | NUT M5                       | 1    |        |
| 099  |           | NUT M6                       | 1    |        |
| 100  |           | NUT M8                       | 5    |        |
| 101  |           | SPRING PIN $\psi$ 4*20       | 4    |        |
| 102  |           | SPRING PIN $\psi$ 5*25       | 1    |        |
| 103  |           | STEEL BALL $\psi$ 6          | 1    |        |
| 104  |           | SPRING $\psi$ 6              | 1    |        |
| 105  |           | OIL IMMERSION LENS $\psi$ 29 | 1    |        |
| 106  |           | C-RING S12                   | 1    |        |

# FEED BEAR BOX - 20 G

2009.12.03

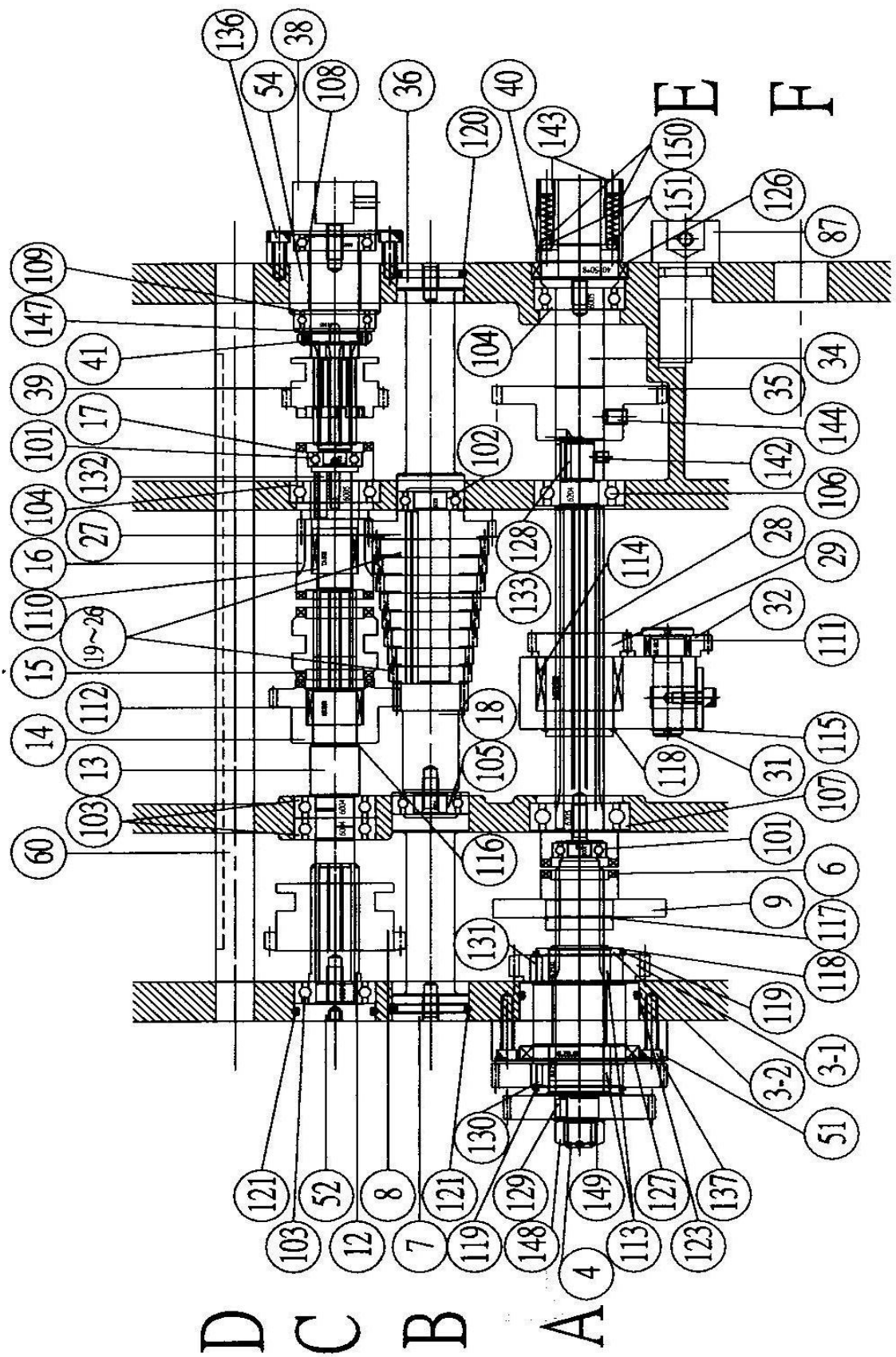

# FEED BEAR BOX - 20·G

2009.12.03

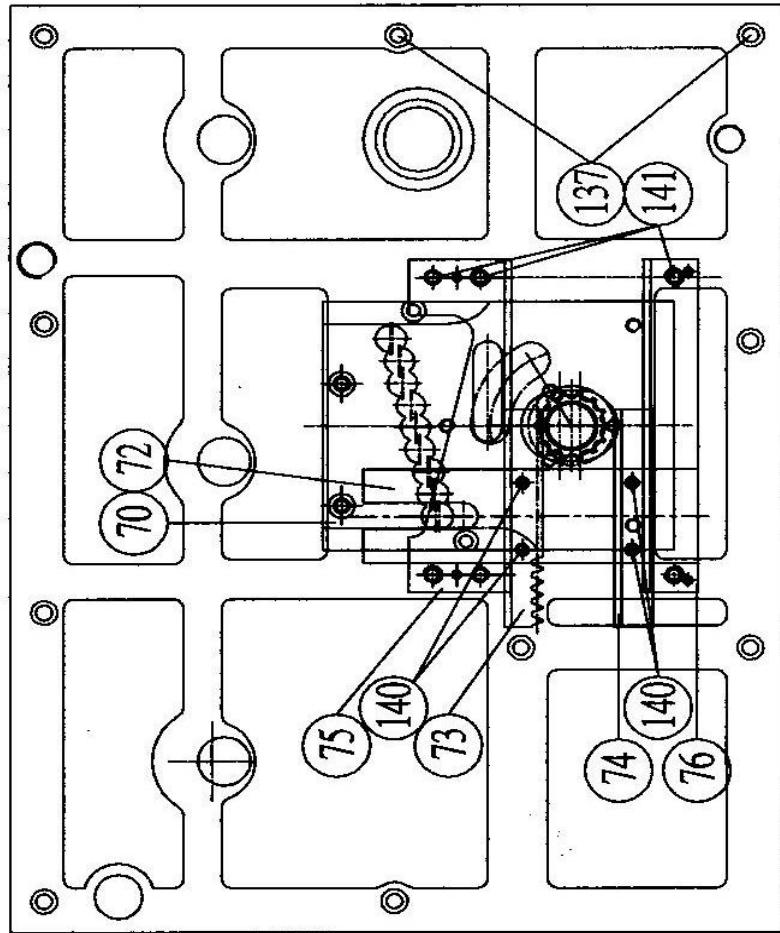
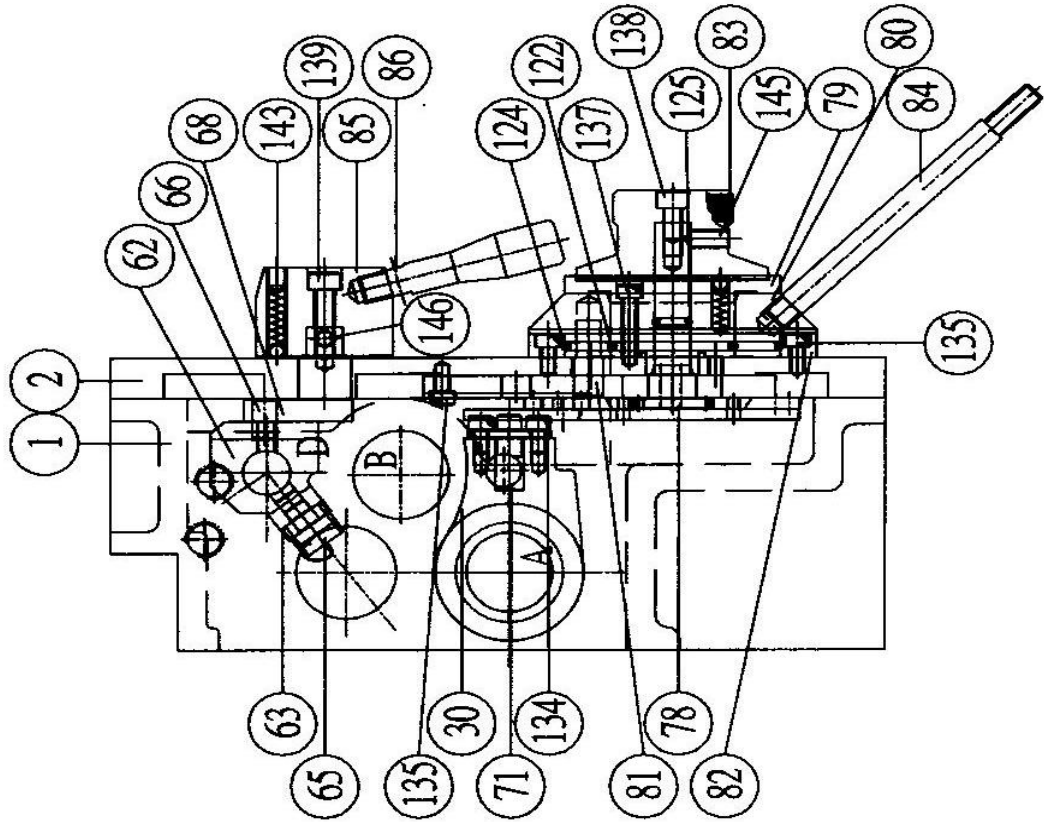

**PART LIST OF 20G FEED GEAR BOX**

| <b>ITEM</b> | <b>PARTS NO.</b> | <b>DESCRIPTION</b>            | <b>Q'TY</b> | <b>REMARK</b> |
|-------------|------------------|-------------------------------|-------------|---------------|
| 01          | 20G-001000       | GEAR BOX BODY                 | 1           |               |
| 02          | 20G-002000       | FRONT COVER                   | 1           |               |
| 03-1        | 20G-003100       | GEAR                          | 1           |               |
| 03-2        | 20G-003200       | SLEEVE                        | 1           |               |
| 04          | 20G-004000       | SHAFT                         | 1           |               |
| 06          | 20G-006000       | CLUTCH                        | 1           |               |
| 07          | 20G-007000       | SHAFT                         | 1           | (SECOND)      |
| 008         | 20G-008000       | GEAR OF CLUTCH                | 1           |               |
| 09          | 20G-009000       | COLLAR                        | 1           |               |
| 12          | 20G-012000       | GEAR                          | 1           |               |
| 13          | 20G-013000       | SHAFT                         | 1           | (THIRD)       |
| 14          | 20G-014000       | GEAR                          | 1           |               |
| 15          | 20G-015000       | CLUTCH                        | 1           |               |
| 16          | 20G-016000       | GEAR OF CLUTCH                | 1           |               |
| 17          | 20G-017000       | GEAR OF CLUTCH                | 1           |               |
| 18          | 20G-018000       | SHAFT                         | 1           | (FOUR)        |
| 19          | 20G-019000       | GEAR                          | 1           | NINE STEP     |
| 20          | 20G-020000       | GEAR                          | 1           | NINE STEP     |
| 21          | 20G-021000       | GEAR                          | 1           | NINE STEP     |
| 22          | 20G-022000       | GEAR                          | 1           | NINE STEP     |
| 23          | 20G-023000       | GEAR                          | 1           | NINE STEP     |
| 24          | 20G-024000       | GEAR                          | 1           | NINE STEP     |
| 25          | 20G-025000       | GEAR                          | 1           | NINE STEP     |
| 26          | 25G-026000       | GEAR                          | 1           | NINE STEP     |
| 27          | 20G-027000       | GEAR                          | 1           |               |
| 28          | 20G-028000       | SHAFT                         | 1           |               |
| 29          | 20G-029000       | GEAR                          | 1           |               |
| 30          | 20G-030000       | SHELF OF ROCKER ARM / HOUSING | 1           |               |
| 31          | 20G-031000       | SHAFT                         | 1           |               |
| 32          | 20G-032000       | GEAR                          | 1           |               |
| 34          | 20G-034000       | SHIFT FORK                    | 1           |               |
| 35          | 20G-035000       | FEED SHAFT                    | 1           |               |

| <b>ITEM</b> | <b>PARTS NO.</b> | <b>DESCRIPTION</b>       | <b>Q'TY</b> | <b>REMARK</b> |
|-------------|------------------|--------------------------|-------------|---------------|
| 36          | 20G-036000       | MIDDLE SHAFT             | 1           |               |
| 38          | 20G-038000       | LEAD SCREW SHAFT         | 1           |               |
| 39          | 20G-039000       | GEAR                     | 1           |               |
| 40          | 20G-040000       | COUPLING SOCKET          | 1           |               |
| 41          | 20G-041000       | NUT                      | 1           |               |
| 51          | 20G-051000       | COVER                    | 1           |               |
| 52          | 20G-052000       | STUFF                    | 1           |               |
| 54          | 20G-054000       | COVER                    | 1           |               |
| 60          | 20G-060000       | SHAFT                    | 1           |               |
| 62          | 20G-062000       | CHANGE SPEED SHIFT BLOCK | 1           |               |
| 63          | 20G-063000       | CHANGE SPEED SHIFT BLOCK | 2           |               |
| 65          | 20G-065000       | CHANGE SPEED SHIFT FORK  | 3           |               |
| 66          | 20G-066000       | CHANGE SPEED SHIFT FORK  | 3           |               |
| 68          | 20G-068000       | ROCKER                   | 3           |               |
| 70          | 20G-070000       | SETTING PLATE            | 1           |               |
| 71          | 20G-071000       | SHIFT SHAFT              | 1           |               |
| 72          | 20G-072000       | SHIFT FORK               | 1           |               |
| 73          | 20G-073000       | SHIFT RACK               | 1           |               |
| 74          | 20G-074000       | SHIFT PIN                | 1           |               |
| 75          | 20G-075000       | SLIDE WEDGE              | 1           |               |
| 76          | 20G-076000       | SLIDE WEDGE              | 1           |               |
| 78          | 20G-078000       | TURNTABLE GEAR           | 1           |               |
| 79          | 20G-079000       | SHELF / HOUSING          | 1           |               |
| 80          | 20G-080000       | SHAFT BASE               | 1           |               |
| 81          | 20G-081000       | SHORT PILLAR             | 1           |               |
| 82          | 20G-082000       | COVER                    | 1           |               |
| 83          | 20G-083000       | SPEED CHANGE DISC        | 1           |               |
| 84          | 20G-084000       | ROCKING LEVER            | 1           |               |
| 85          | 18HA-068000      | SPEED CHANGE LINK BASE   | 3           |               |
| 86          | 18HA-069000      | SPEED CHANGE SHAFT       | 3           |               |
| 87          | 20B-017000       | SHORT SHAFT              | 1           |               |
| 88          | 20B-034000       | GEAR                     | 1           |               |

| ITEM | PARTS NO. | DESCRIPTION      | Q'TY | REMARK |
|------|-----------|------------------|------|--------|
| 101  |           | BEARING 6001     | 2    |        |
| 102  |           | BEARING 6003     | 1    |        |
| 103  |           | BEARING 6004     | 3    |        |
| 104  |           | BEARING 6005     | 2    |        |
| 105  |           | BEARING 6203     | 1    |        |
| 106  |           | BEARING 6204     | 1    |        |
| 107  |           | BEARING 6205     | 1    |        |
| 108  |           | BEARING 6905ZZ   | 1    |        |
| 109  |           | BEARING 51105    | 1    |        |
| 110  |           | BEARING TA1725   | 1    |        |
| 111  |           | BEARING HK1812   | 1    |        |
| 112  |           | BEARING HK2220   | 1    |        |
| 113  |           | BEARING HK2520   | 1    |        |
| 114  |           | BEARING TA3530   | 1    |        |
| 115  |           | C LOCKER S15     | 1    |        |
| 116  |           | C LOCKER S22     | 1    |        |
| 117  |           | C LOCKER S25     | 1    |        |
| 118  |           | C LOCKER S35     | 2    |        |
| 119  |           | C LOCKER S45     | 2    |        |
| 120  |           | O RING G30       | 1    |        |
| 121  |           | O RING G35       | 2    |        |
| 122  |           | O RING G45       | 1    |        |
| 123  |           | O RING G55       | 1    |        |
| 124  |           | O RING G85       | 1    |        |
| 125  |           | O RING P11       | 1    |        |
| 126  |           | OIL SEAL 40*55*8 | 1    |        |
| 127  |           | OIL SEAL 48*62*8 | 1    |        |
| 128  |           | KEY 5*5*20       | 1    |        |

| ITEM | PARTS NO. | DESCRIPTION            | Q'TY | REMARK |
|------|-----------|------------------------|------|--------|
| 129  |           | KEY 6*6*10             | 1    |        |
| 130  |           | KEY 6*6*12             | 1    |        |
| 131  |           | KEY 6*6*14             | 1    |        |
| 132  |           | KEY 6*6*25             | 1    |        |
| 133  |           | KEY 6*6*95             | 1    |        |
| 134  |           | CAP SCREW M6*10        | 2    |        |
| 135  |           | CAP SCREW M6*12        | 5    |        |
| 136  |           | CAP SCREW M6*20        | 4    |        |
| 137  |           | CAP SCREW M6*30        | 16   |        |
| 138  |           | CAP SCREW M8*14        | 1    |        |
| 139  |           | CAP SCREW M8*30        | 3    |        |
| 140  |           | SEMICIRCLE SCREW M5*10 | 4    |        |
| 141  |           | SEMICIRCLE SCREW M6*20 | 6    |        |
| 142  |           | SETSCREW M6*6          | 1    |        |
| 143  |           | SETSCREW M8*8          | 5    |        |
| 144  |           | SETSCREW M8*10         | 1    |        |
| 145  |           | SETSCREW M8*16         | 1    |        |
| 146  |           | SETSCREW M8*20         | 3    |        |
| 147  |           | SPACER                 | 1    |        |
| 148  |           | NUT M16                | 1    |        |
| 149  |           | SPRING SPACER M16      | 1    |        |
| 150  |           | SPRING DIA.6MM         | 6    |        |
| 151  |           | STEEL BALL DIA.6MM     | 6    |        |

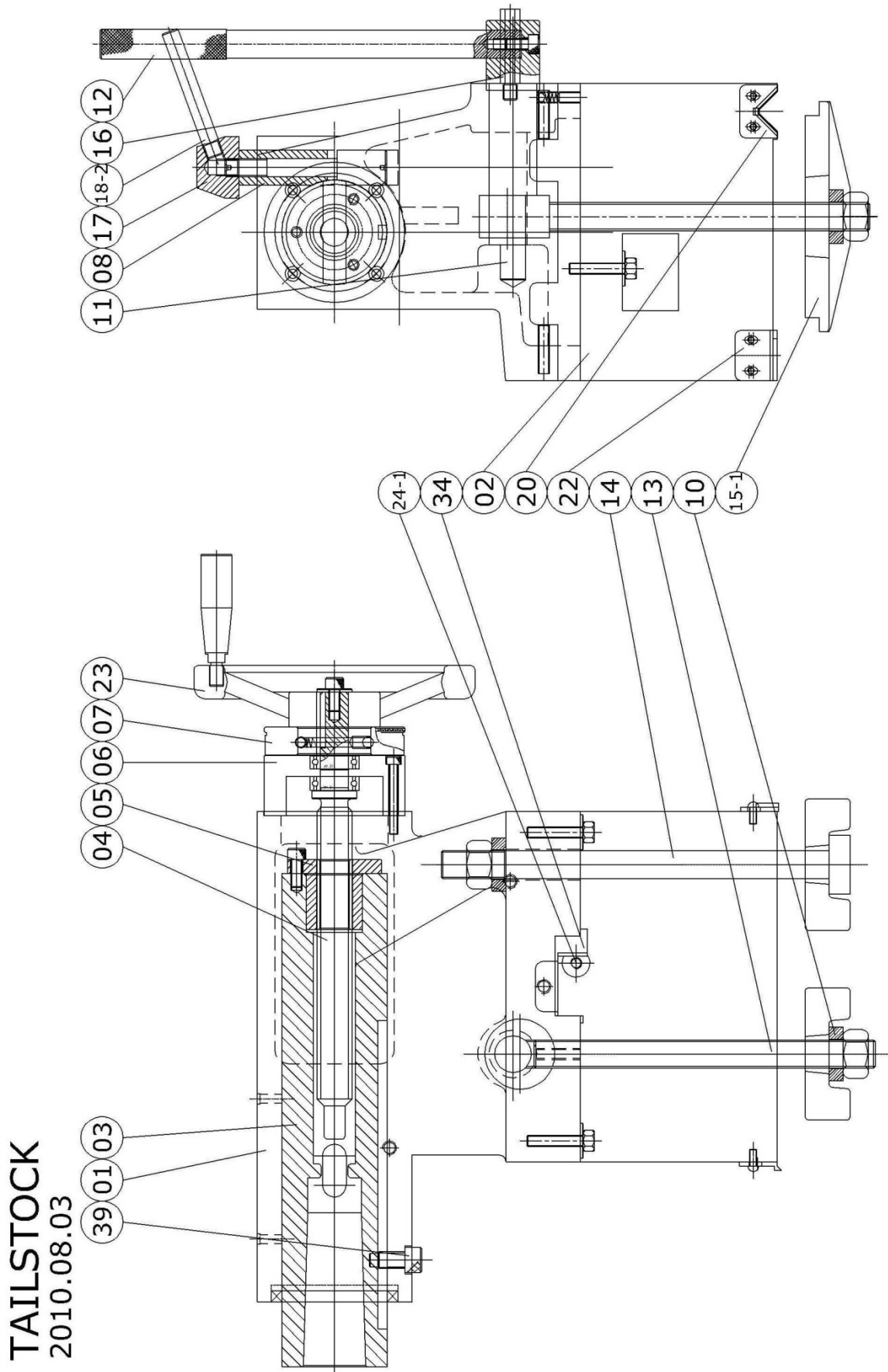



PART LIST OF TAILSTOCK-18/21/25T

| ITEM  | PARTS NO.   | DESCRIPTION         | Q'TY | NOTE      |
|-------|-------------|---------------------|------|-----------|
| 001   | 25T-001000  | TAILSTOCK BODY      | 1    | H4 TURRET |
| 002   | 18T-002000  | BASE                | 1    |           |
|       | 21T-002000  | BASE                | 1    |           |
|       | 25T-002000  | BASE                | 1    |           |
| 003   | 25T-003000  | QUILL               | 1    |           |
|       | 25T-0040M0  | SCREW               | 1    | MM        |
| 004   | 25T-0040I0  | SCREW               | 1    | INCH      |
|       | 25T-0040M0  | SCREW               | 1    | MM        |
| 005   | 25T-0050M0  | NUT                 | 1    | MM        |
|       | 25T-0050I0  | NUT                 | 1    | INCH      |
| 006   | 25T-006000  | BRACKET             | 1    |           |
| 007   | 25T-0070M0  | DIAL                | 1    | MM        |
|       | 25T-0070I0  | DIAL                | 1    | INCH      |
| 008   | 25T-008009B | NIPPING STUD        | 1    |           |
| 010   | 25T-010000  | WASHER              | 1    |           |
| 011   | 25T-011000  | ECCENTRIC LOCK STUD | 1    |           |
| 012   | 25T-012000  | LOCKING LEVER       | 1    |           |
| 013   | 18T-013000  | CLAMPING BOLT       | 1    |           |
|       | 21T-013000  | CLAMPING BOLT       | 1    |           |
|       | 25T-013000  | CLAMPING BOLT       | 1    |           |
| 014   | 18T-014000  | CLAMPING BOLT       | 1    |           |
|       | 21T-014000  | CLAMPING BOLT       | 1    |           |
|       | 25T-014000  | CLAMPING BOLT       | 1    |           |
| 015-1 | 25T-015100  | HOLDING DOWN PLATE  | 2    |           |
| 016   | 25T-016000  | STOP PIN            | 1    |           |
| 017   | 25T-017000  | NIPPING NUT         | 1    |           |
| 018-2 | 25T-018200  | HANDLE              | 1    |           |
| 020   | 25T-020000  | WIPER               | 2    |           |
| 022   | 25T-022000  | WIPER               | 2    |           |
| 023   | 25A-010000  | HAND WHEEL          | 1    |           |
| 024-1 | 25S-024100  | ADJUSTMENT BOLTS    | 2    |           |
| 034   | 25T-034000  | GIB                 | 1    |           |
| 039   | 25T-039000  | FIXING SCREW        | 1    |           |

TAILSTOCK  
2010.08.03

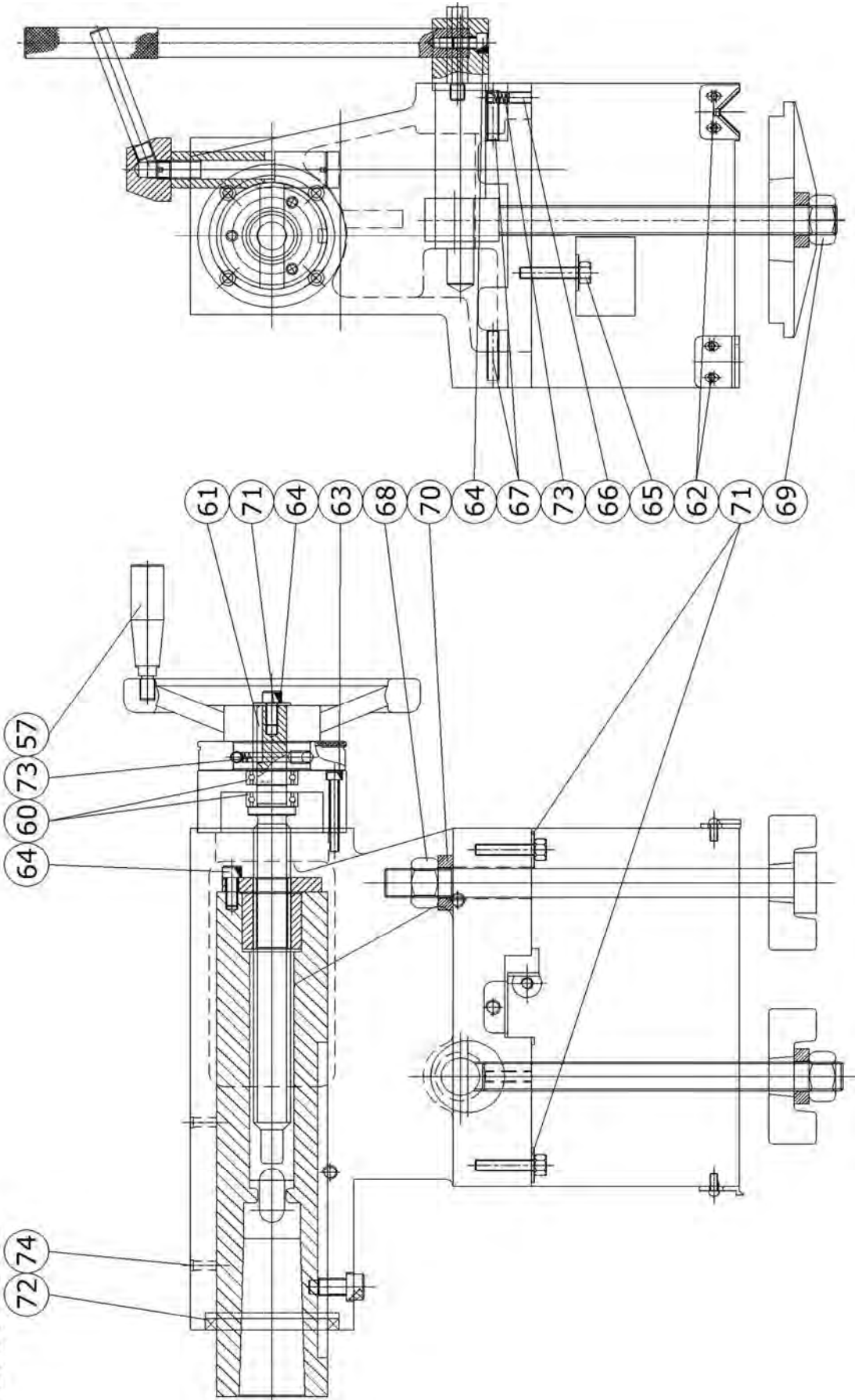

Parts list of 18/21/25 Manual Tailstock

| <b>ITEM</b> | <b>PARTS NO.</b> | <b>DESCRIPTION</b>  | <b>Q'TY</b> | <b>NOTE</b> |
|-------------|------------------|---------------------|-------------|-------------|
| 057         | 25T-057000       | HANDLE              | 1           |             |
| 060         |                  | BEARING 51104       | 2           |             |
| 061         |                  | KEY 6*6*14          | 1           |             |
| 062         |                  | SCREW M5*12         | 4           |             |
| 063         |                  | SCREW M6*50         | 4           |             |
| 064         |                  | SCREW M8*20         | 5           |             |
| 065         |                  | SCREW M8*40         | 2           |             |
| 066         |                  | SCREW M6*16         | 1           |             |
| 067         |                  | SCREW M8*35         | 2           |             |
| 068         |                  | NUT 3/8"            | 1           |             |
| 069         |                  | NUT M20             | 1           |             |
| 070         |                  | SPACER 20*37*4      | 1           |             |
| 071         |                  | SPACER M8           | 3           |             |
| 072         |                  | OIL SEAL 75*90*8    | 1           |             |
| 073         |                  | STEEL BALL & SPRING | 2           |             |
| 074         |                  | OIL NIPPLE          | 2           |             |

STEADY REST

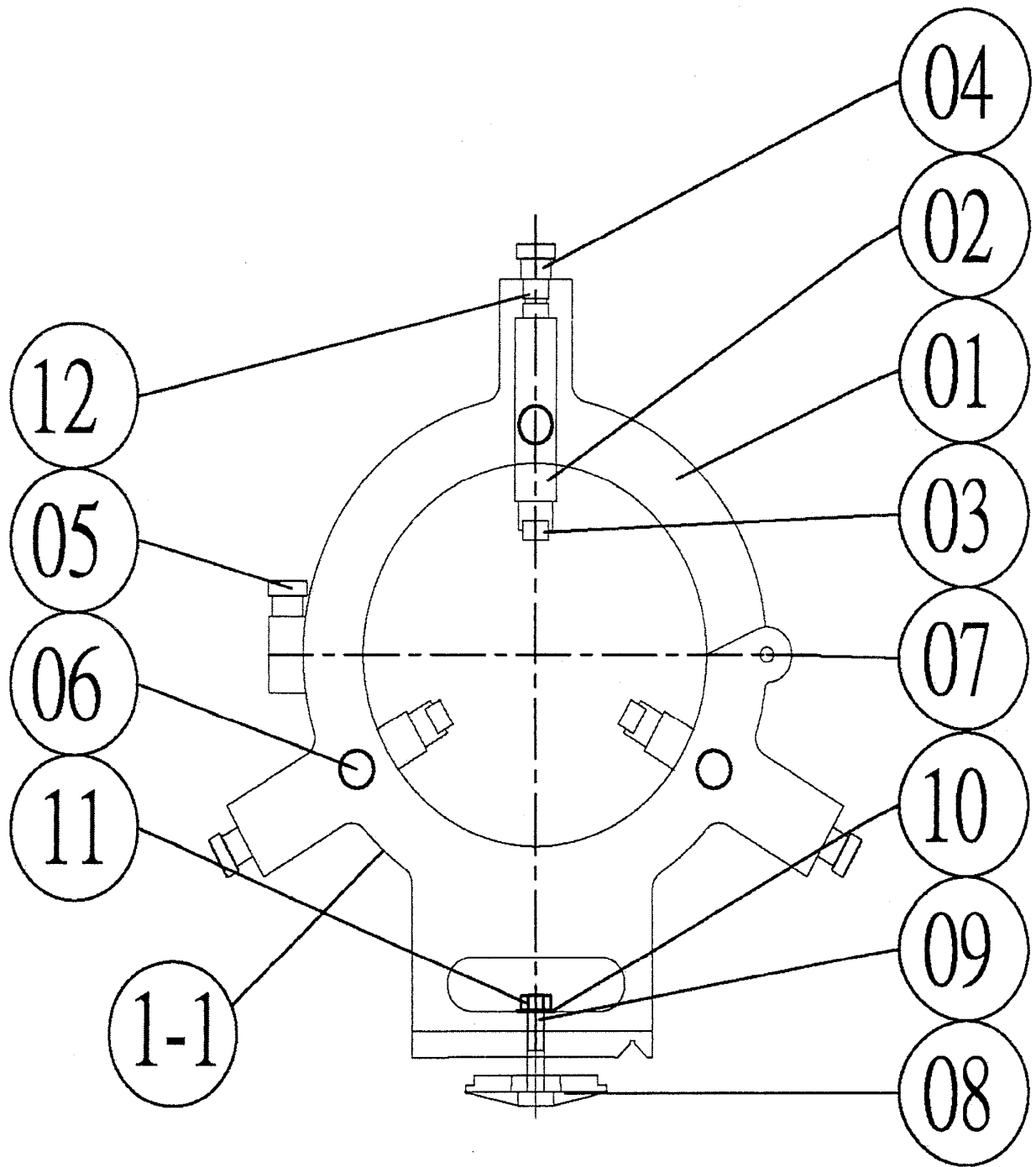

Part List of STEADY REST-21" Series

| ITEM   | PARTS NO.  | DESCRIPTION               | Q'TY | NOTE |
|--|------------|---------------------------|------|------|
| 1  | 21SR-001   | Steady rest housing-top   | 1    |      |
| 2  | 21SR-002   | Steady rest housing-lower | 1    |      |
| 3  | 21SR-003   | Roller shaft              | 3    |      |
| 4  | 21SR-004   | Shaft roller              | 3    |      |
| 5  | 21SR-005   | Adjusting knob            | 3    |      |
| 6  | 21SR-006   | Housing tighten knob      | 1    |      |
| 7  | 21SR-007   | Shaft locating screw      | 3    |      |
| 8  | 21SR-008   | Housing connecting screw  | 1    |      |
| 9  | 25T-015100 | Locating plate            | 1    |      |
| 10   |            | Socket head cap screw     | 1    |      |
| 11   |            | Square washer             | 1    |      |
| 12   |            | Hex nut                   | 1    |      |
| 13   | 21SR-009   | Adjusting shaft           | 1    |      |
| For 25" series lathe, please replace 21 with 25 when ordering replacement parts. |            |                           |      |      |

**FOLLOW REST**

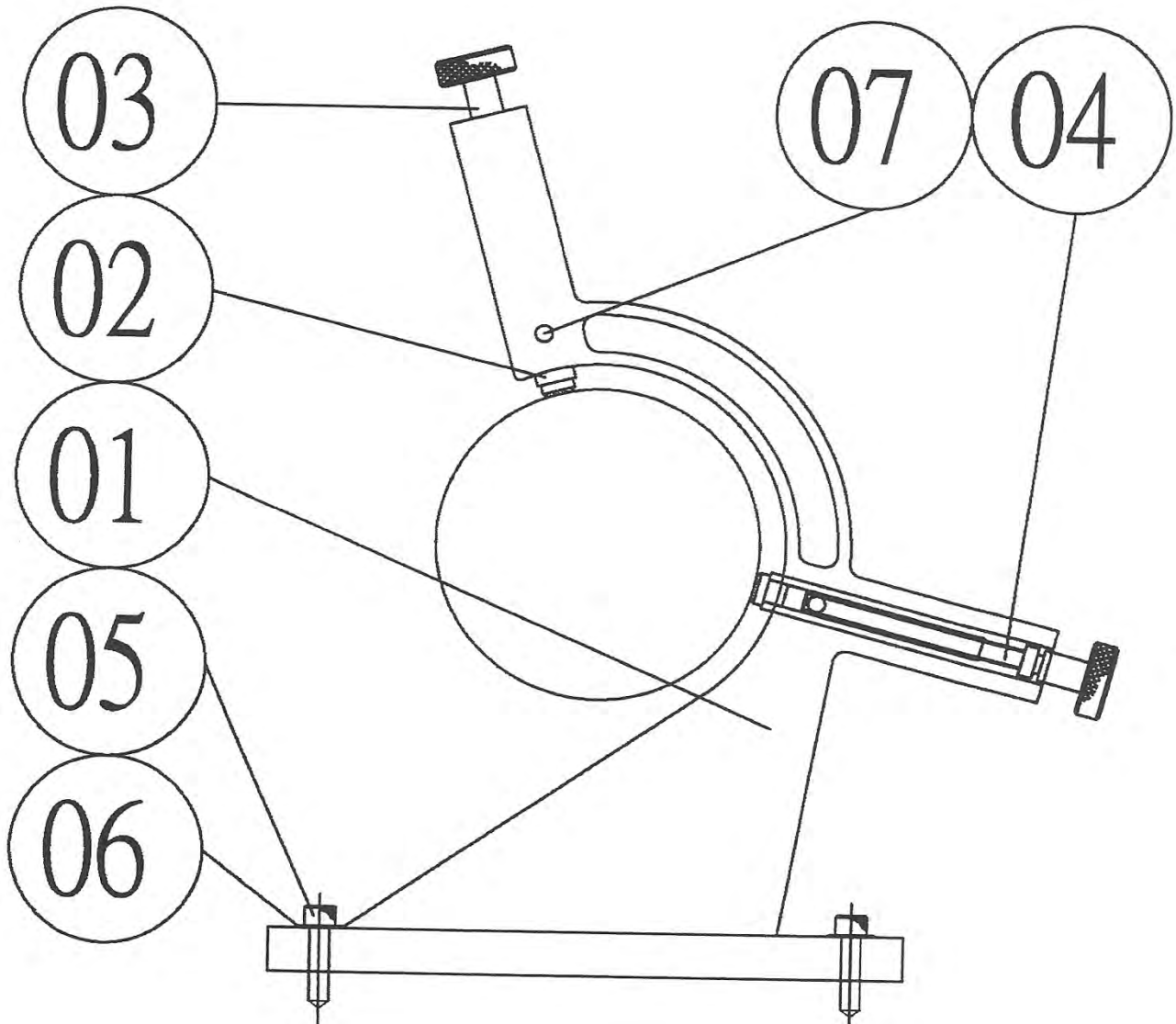

Part List of FOLLOW REST- 21" Series

| ITEM | PARTS NO. | DESCRIPTION           | Q'TY | NOTE |
|------|-----------|-----------------------|------|------|
| 1    | 21FR-001  | Follow rest housing   | 1    |      |
| 2    | 21FR-002  | Shaft with brass tip  | 2    |      |
| 3    | 21FR-003  | Adjusting knob        | 2    |      |
| 4    | 21FR-004  | Shaft screw           | 2    |      |
| 5    |           | Socket head cap screw | 2    |      |
| 6    |           | Washer                | 2    |      |
| 7    |           | Socket head cap screw | 2    |      |

For 25" series lathe, please replace 21 with 25 when ordering replacement parts.

# TAPER TURNING ATTACHMENT

## Taper attachment

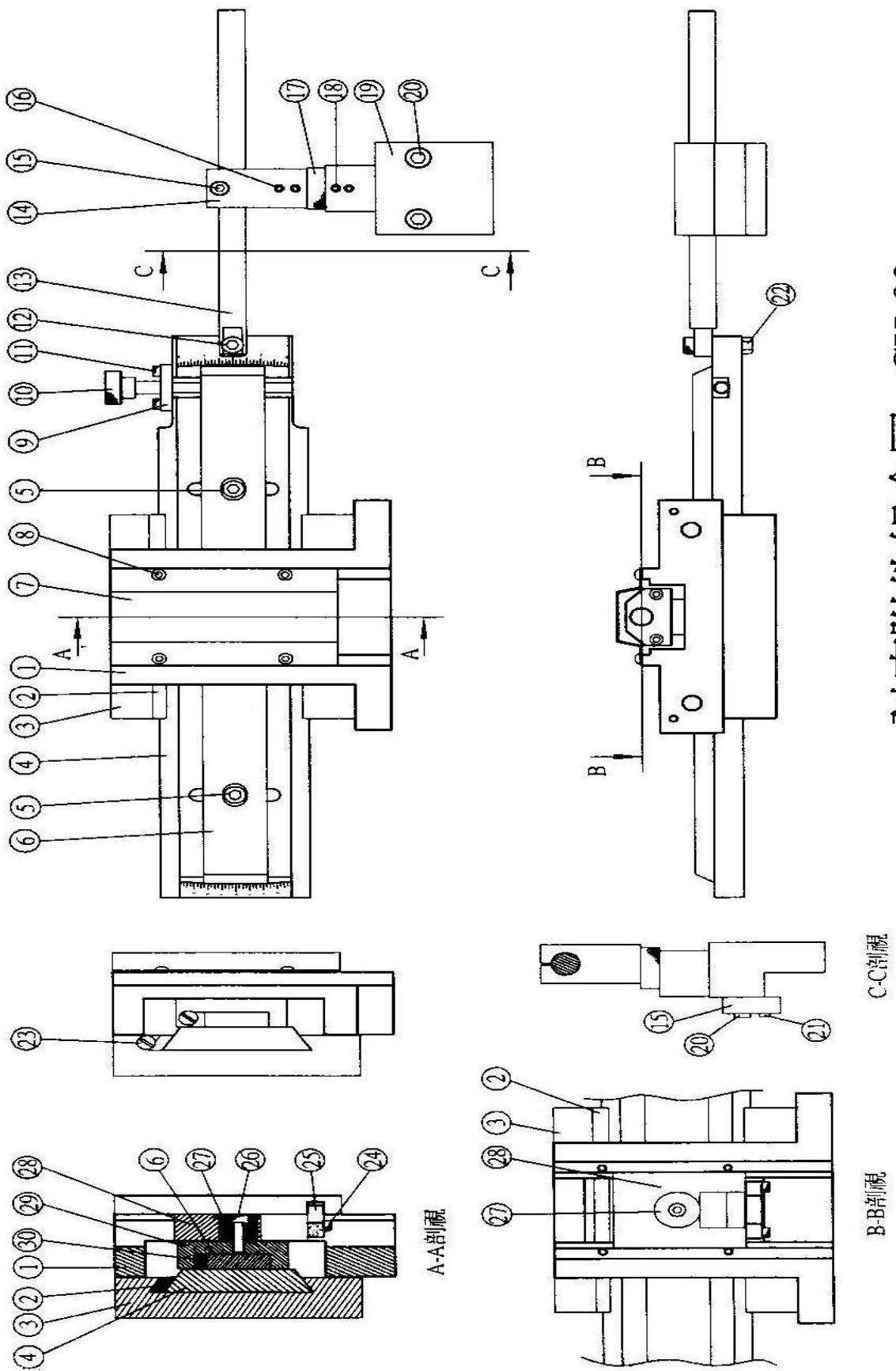

Part List of TAPER TURNING ATTACHMENT- 21" Series

| ITEM | PARTS NO. | DESCRIPTION                        | Q'TY | NOTE |
|------|-----------|------------------------------------|------|------|
| 1    | 21TA-001  | Taper attachment body casting      | 1    |      |
| 2    | 21TA-002  | Gib-taper turning attachment       | 1    |      |
| 3    | 21TA-003  | Topslide casting                   | 1    |      |
| 4    | 21TA-004  | Sliding body                       | 1    |      |
| 5    | 21TA-005  | Socket head cap screw              | 2    |      |
| 6    | 21TA-006  | Rotating sliding plate             | 1    |      |
| 7    | 21TA-007  | Top cover                          | 1    |      |
| 8    | 21TA-008  | Round head cap screw +             | 4    |      |
| 9    | 21TA-009  | Locating plate                     | 1    |      |
| 10   | 21TA-010  | Screw with knob                    | 1    |      |
| 11   | 21TA-011  | Socket head cap screw              | 2    |      |
| 12   | 21TA-012  | Socket head cap screw              | 1    |      |
| 13   | 21TA-013  | Connecting shaft                   | 1    |      |
| 14   | 21TA-014  | Connecting bracket                 | 1    |      |
| 15   | 21TA-015  | Socket head cap screw              | 1    |      |
| 16   | 21TA-016  | Socket cap set screw               | 2    |      |
| 17   | 21TA-017  | Dual side connecting shaft         | 1    |      |
| 18   | 21TA-018  | Socket cap set screw               | 2    |      |
| 19   | 21TA-019  | Shaft locating bracket             | 1    |      |
| 20   | 21TA-020  | Socket head cap screw              | 2    |      |
| 21   | 21TA-021  | Socket cap set screw               | 1    |      |
| 22   | 21TA-022  | Hex nut                            | 2    |      |
| 23   | 21TA-023  | Gib screw-taper turning attachment | 2    |      |
| 24   | 21TA-024  | Socket head cap screw              | 4    |      |
| 25   | 21TA-025  | Screw connecting bracket           | 1    |      |
| 26   | 21TA-026  | Socket head cap screw              | 1    |      |
| 27   | 21TA-027  | Sleeve                             | 1    |      |
| 28   | 21TA-028  | Connecting plate                   | 1    |      |
| 29   | 21TA-029  | Plate                              | 1    |      |
| 30   | 21TA-030  | Gib                                | 1    |      |

For 25" series lathe, please replace 21 with 25 when ordering replacement parts.