



Springwood Industrial, Inc.
1062 N. Kraemer Place
Anaheim, CA 92806
Tel: 714-632-9701 Fax: 714-632-9730
<http://www.aceronline.net>

info@acergroup.com

Klim Industrial, Inc.
244 N. Randolphville Road
Piscataway, NJ 08854
Tel: 732-752-9100 Fax: 732-752-9101
<http://www.aceronline.net>

acer_klim@yahoo.com

PROCEDURE TO ADJUST TABLE MOVEMENT FOR SUPRA 1428AHD AND ABOVE

8.3 : HYDRAULIC OIL PRESSURE ADJUSTMENT

Parts Name:

A: Oil pressure adjusting valve

B1, B2: Table reversing pressure adjustment valve for single side (speed-up time).

C1, C2 : Valve to adjust the length of table transverse (braking distance).

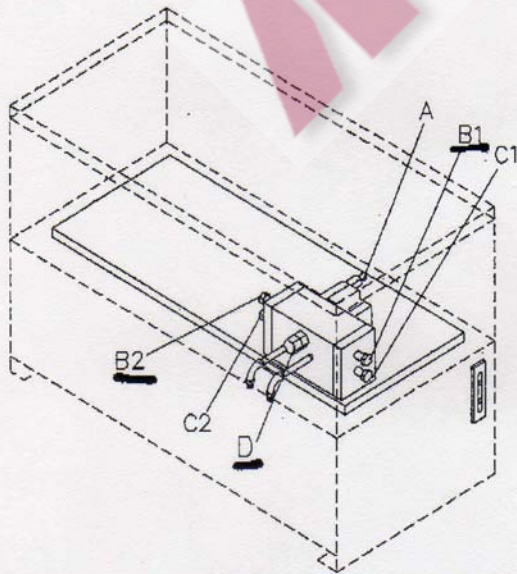

D: Table reversing pressure adjustment valve (effect both sides together).

1. "A" valve is properly-adjusted before shipment. Unless it is necessary, please don't re-adjust this valve. To increase the pressure, screw in clockwise ;To decrease the pressure, screw counter clockwise.

Table speed limit: 25 meters/per minute (power supply: 60 Hz)

20 meters/per minute (power supply: 50Hz)

2. **B1, B2** valve, use these valves to adjust the same reversing pressure at table-reversing action. This is to ensure smooth table movement. Please note that, not to adjust any of the two valves unless there is obvious difference occurs on reversing speed.

3. **C1, C2** valves are the adjustment for braking length of table transverse. Only when the length of both sides are different, then it's necessary to adjust them. To adjust, clockwise will shorten the distance; to adjust, counter-clockwise will increase the distance. We've adjusted the distance within 35 ~ 65mm in factory.

4. **D** valve is to adjust the impulse force. This valve should only be adjusted when all other valves are adjusted. To adjust D valve, clockwise will make the impulse force smaller; to adjust counter-

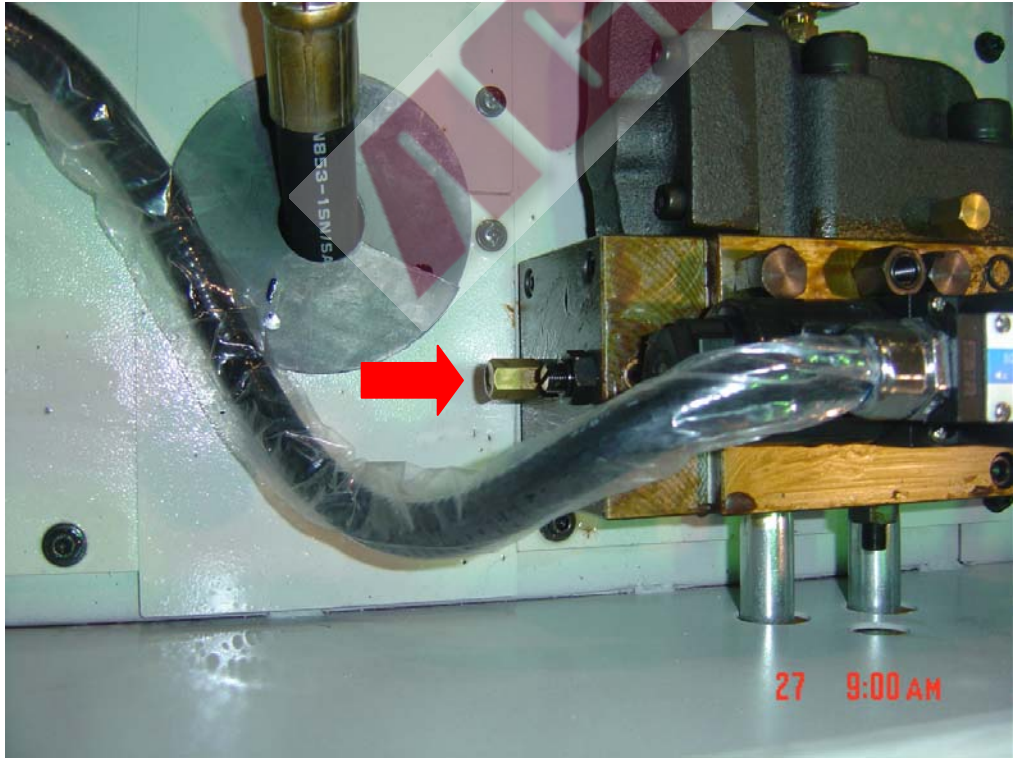
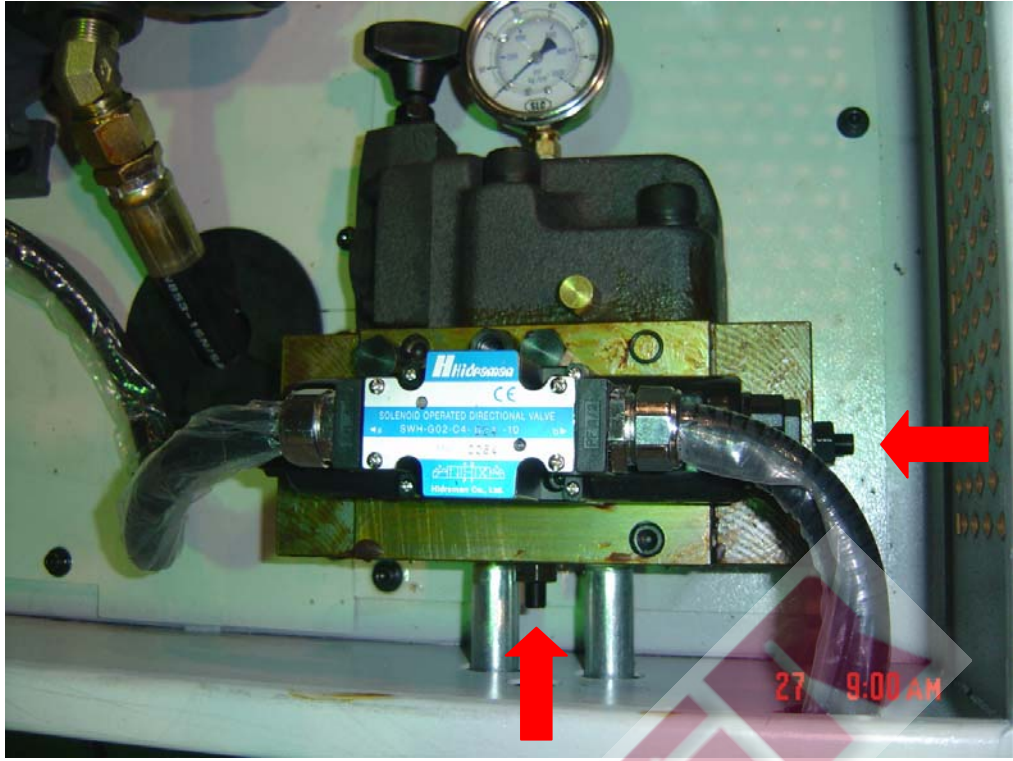

1. Adjust (A) hydraulic pressure within 15kg/cm².
2. Turn off hydraulic motor.
3. Adjust B1, B2, & D. Loosen the lock nut, turn adjusting screw backwards, (counterclockwise). B1 & B2, about 5-6 turns. D, about one turn, (a small amount).
4. Lock B1, B2 nut, but not D. Turn on hydraulic motor, use a small stroke and slowly turn on the hydraulic valve to move the table slowly.
5. Table movement will cause the table to have a “clutching” noise, and when moving left and right and shocking movement will happen.

End stroke will cause different speed and vibration, because the reverse distance becomes shorter and cause shock. Adjust B1 and B2, (do not adjust D.) Turn B1 & B2 screw clockwise to increase longer (soft) stroke and smooth reversing.
6. After adjusting left and right reversing stroke smoothly, then lock B1, B2, & D nut.
7. Only adjust B1, B2, & D. Do not touch other screws.