

Springwood Industrial, Inc.  
1062 N. Kraemer Place  
Anaheim, CA 92806  
Tel: 714-632-9701 Fax: 714-632-9730  
<http://www.aceronline.net>  
[info@aceronline.net](mailto:info@aceronline.net)

Klim Industrial, Inc.  
244 N. Randolphville Road  
Piscataway, NJ 08854  
Tel: 732-752-9100 Fax: 732-752-9101  
<http://www.aceronline.net>  
[acer\\_klim@yahoo.com](mailto:acer_klim@yahoo.com)

## PROCEDURE TO SETUP SUPRA 1640AHD SURFACE GRINDER

1. Unwrap the machine and check out machine for any physical damage. If so, report to your dealer as soon as possible. Touch-up paint is inside the toolbox. Use it as needed.



2. Unwrap control panel and remove supporting bracket.

3. Turn vertical handwheel counterclockwise (spindle up) to take out spindle support block. Swing out control panel out when removing spindle support block.



4. Move machine to appropriate location. Put leveling screw, nut and pad on machine (follow picture)

5. Remove the six transportation brackets



6. Check input power that will be used for the machine. Power required for our machines are: 230V three phase (3 $\Phi$ ) or 460V three phase (3 $\Phi$ ). Power must be first specified upon ordering. Please connect the power to R, S, T, Ground terminal as follows with minimum current of 45 amps (230V).



7. Hook up electronic conduct connectors, two from hydraulic system, one from magnetic separator and paper filter and one for the light.

8. Connect two corresponding hydraulic hoses: A-A and B-B.



9. Fill up hydraulic oil (minimum 30 gallons) and lubricating oil. Make sure filling gauge is at F.



10. Turn on control. Make sure all the motors are running clockwise (spindle motor, hydraulic motor, cross-feed motor, vertical rapid motor, and coolant pump motor).
  - 1) Turn on main power breaker. Release emergency button. Turn chuck control on.
  - 2) Press spindle, hydraulic (hydraulic valve must be in off position) and magnetic separator and paper filter system buttons to check rotation.
  - 3) Check cross-feed motor by pressing in and out push button while function switch is in manual mode.
  - 4) Check rapid vertical motor by pressing up and down push buttons while function switch is in rapid mode.

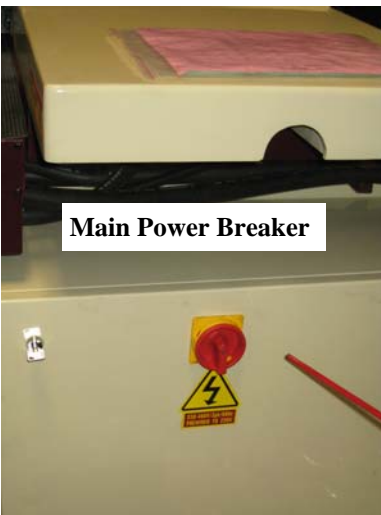

Main Power Breaker

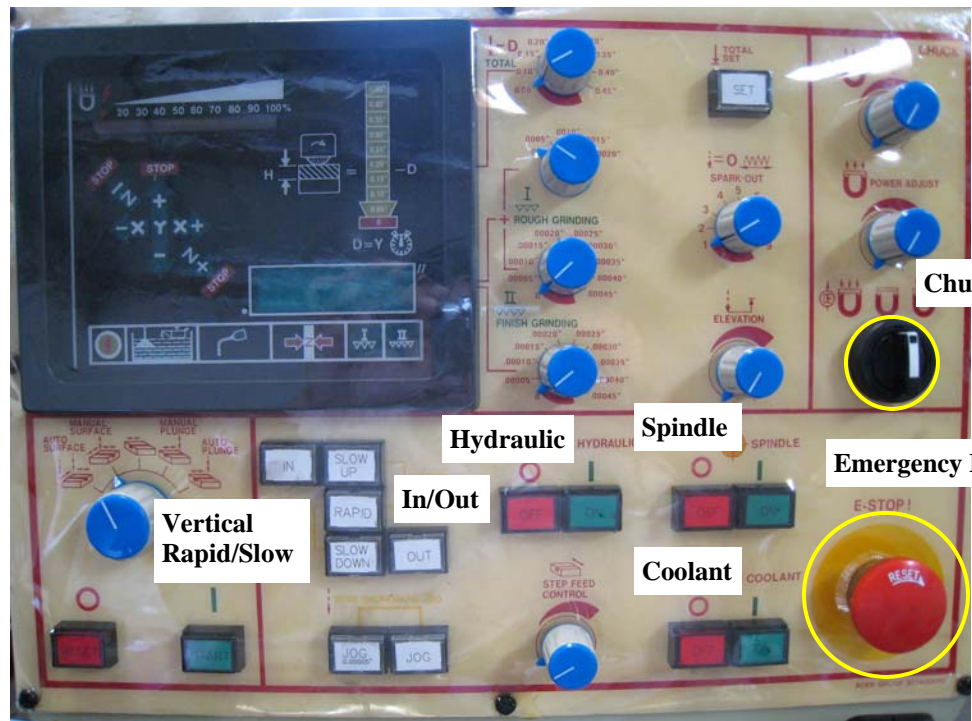

Chuck Control

Emergency Button

Spindle

Hydraulic

In/Out

Vertical Rapid/Slow

Coolant

If opposite direction, please turn off main power by pushing emergency button. Switch any two power lines that go into the machine.





11. Put back the rear column cover.

## 12. Level Machine

### 4.5 : Adjust the leveling of machines

Please adjust the leveling very carefully because the first installation will affect the precision and the life of machine. And surely will affect the precision of your work piece.

The accuracy of the level gauge is 0.02mm/M or 0.0008in/40in, and please adjust the level of machine within 0.02mm/M. The procedure of adjustment is as below:

- (1) : As the drawing shown below, put the leveling gauge on the table. Make sure the table is in the center of machine. Place level gauge (A) in crosswise direction, and put the level gauge (B) in the longitudinal direction.
- (2) : Check with chapter 4.4.2. Adjust the fixing bolts NO. 4,5, until the bubble of level gauge (B) comes to the center, then adjust the fixing bolt (1) until the bubble of level gauge (A) comes to the center on the level gauge.
- (3) : Screw tight the fixing nuts (NO. 6) on the leveling bolts NO.1,4,5.
- (4) : Screw tight the leveling bolts NO. 2,3. Make sure they have touched leveling blocks, and the bubble of the level gauge on the machine doesn't move, then screw tight the nut NO. 6.
- (5) : Turn the hand wheel of the table. Make the table move left or right, then check if the bubble of level gauge (B) is still within 0.02mm/M.
- (6) : Turn the hand wheel of saddle. Check the bubble on level gauge (A), to see if it is still within 0.02mm/M.
- (7) : If the bubble of level gauge in procedure (5) & (6) is over 0.02mm/M, please adjust according procedure (1), (2),(3), &(4).
- (8) : Please use hammer to slightly tap the leveling pads again after all the procedure had done. This is to ensure all leveling bolts are firmly supported.

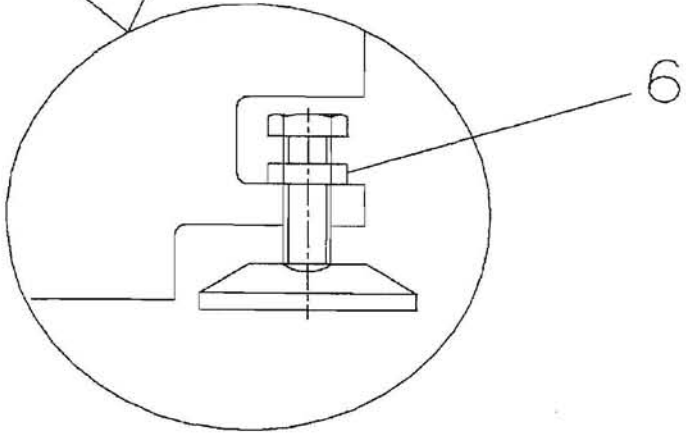
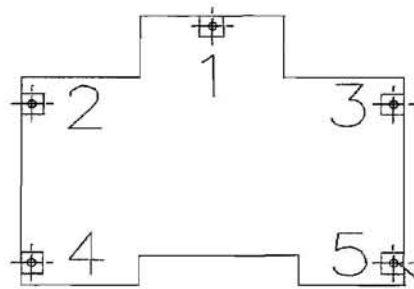
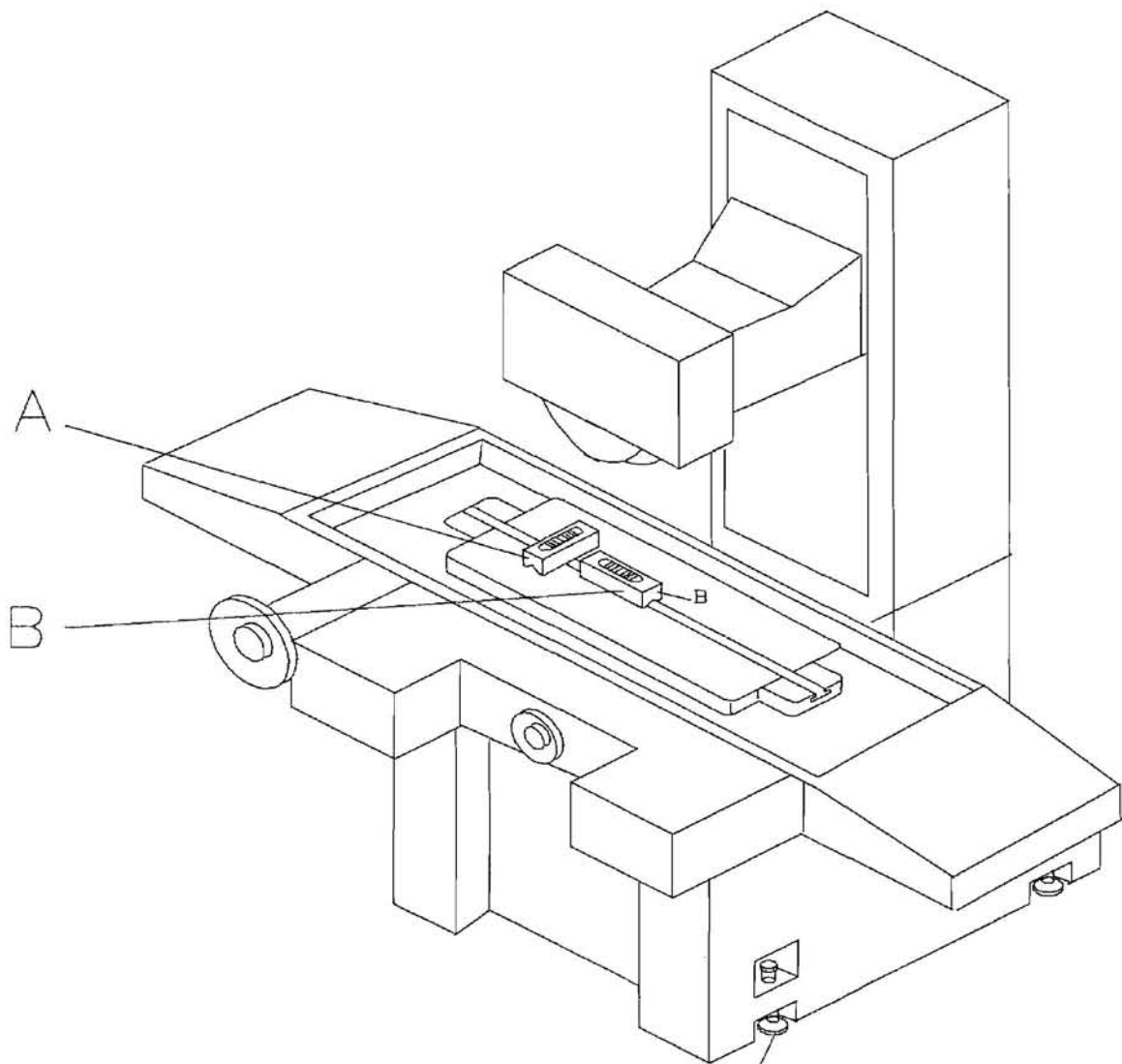

3.2

13. For auto lube pump, we recommend you use way oil #2 or for hydraulic oil, use Mobil DTE 25 or follow the manual suggestion.



14. Read through the operation manual and choose the correct wheel for application.
15. Ready to run your grinder: please read through the Supra 1428/1632/1640AHD manual to familiarize yourself with all functions, features and controls.
16. Should you have any questions or comments, please contact your local dealer first. They will then refer you to Acer 714-632-9701 (west coast) or 732-752-9100 (east coast) for further assistance.