



Springwood Industrial, Inc.
1062 N. Kraemer Place
Anaheim, CA 92806
Tel: 714-632-9701 Fax: 714-632-9730
<http://www.acergroup.com>

info@acergroup.com

Klim Industrial, Inc.
244 N. Randolphville Road
Piscataway, NJ 08854
Tel: 732-752-9100 Fax: 732-752-9101
<http://www.acergroup.com>

acer_klim@yahoo.com

PROCEDURE TO SETUP SUPRA 618IIASD SURFACE GRINDER

1. Unwrap the machine and check out machine for any physical damage. If so, report to your dealer as soon as possible. Touch-up paint is inside the toolbox. Use it as needed.



2. Remove control support, turn control to face front.



3. Turn vertical handwheel clockwise (spindle up) to take out spindle support block (See figure on left). Move machine to appropriate location. Put 3 leveling screw, nut and pad on machine (See figure on right).



4. Remove the two brackets.

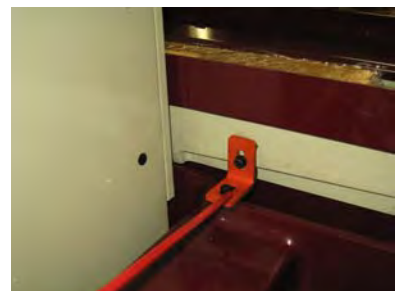



5. Use a wrench to loosen the two lock nuts.

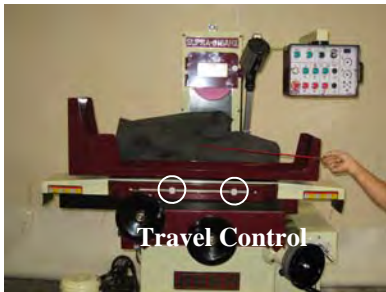

6. Put rubber pad behind table. Raise wheel all the way up, and put the crossfeed all the way out. Slide the table travel control dog to the end of the travel (See figure on left). Have two people lift table and set it on the rubber pad (See figure on right). **Be cautious, do not let the table touch the table travel sensor** (See figure below).



7. Replace PVC tube with ball rolling way. Place the longer rack with 21 steel balls in the rear, and shorter rack with 20 steel balls in the front (See figure on left). **Put back table, but be cautious, do not let the table touch the table travel sensor** (See figure on right).



8. **After putting back the table the table, please tighten the two lock nuts back!**

9. When putting back the table; the table bracket should be inside the stopper.

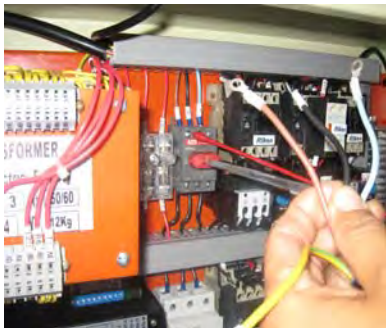

10. Check input power that will be used for the machine. Power required for our machines are: 230V three phase (3Φ) or 460V three phase (3Φ). Power must be first specified upon ordering. Please connect the power to R.S.T.G Ground terminal as follows with minimum current of 9 amps (230V).

11. Hook up two electronic conduct connectors and wire, from hydraulic system, one from dust suction and coolant system.



12. Connect two corresponding hydraulic hoses: A-A, B-B as labeled to the hydraulic system.



13. Fill up hydraulic oil Mobile DTE25 (minimum 10 gallons) and lubricating oil (See figure on left). Make sure filling gauge is at F. Fill up one gallon lube oil Mobile Vactra #2 way oil or Chevron Waylube #68 or equivalent. (See figure on right). For new machines, change oil after three months. Change oil every six months



14. Turn on control. Make sure all the motors are running clockwise (spindle motor, hydraulic motor, cross-feed motor, and coolant pump motor). 1) Turn on Main Power switch (See Fig. 1) Release emergency button. (See Fig. 2) 2) Put the Hydraulic valve at the off position. Press hydraulic (See Fig. 3 & 4) first, spindle (See Fig. 5 & 6), to check rotation. 3) Check cross-feed motor by toggling in and out switch while function switch is in manual mode & surface grinding mode (See Fig. 7).

Machine is prewired at our facility when you order. Check the rotation of the hydraulic motor is running clockwise. Most of the other motors are running correct accordingly.



Fig. 1



Fig. 2



Fig. 3



Fig. 5

Tap wheel with object to make sure wheel is not cracked. The sound should be clear and consistent.

Fig. 4

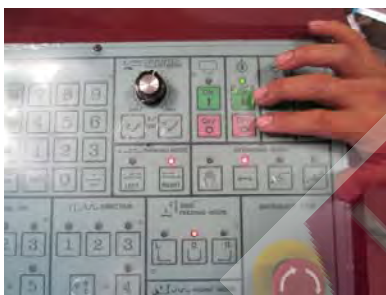
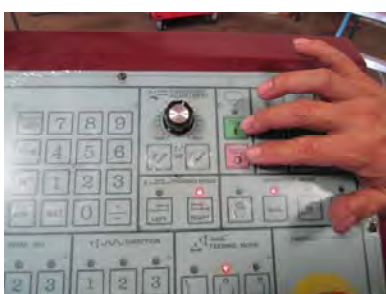

Fig. 7

Fig. 6

Push On and Off immediately, Make sure spindle rotation is clockwise.



15. Leveling the machine

Precisely level the machine on a solid foundation. Precise leveling of the grinder is important to the finish of the product and the tolerance of the machine.

C. Levelling:

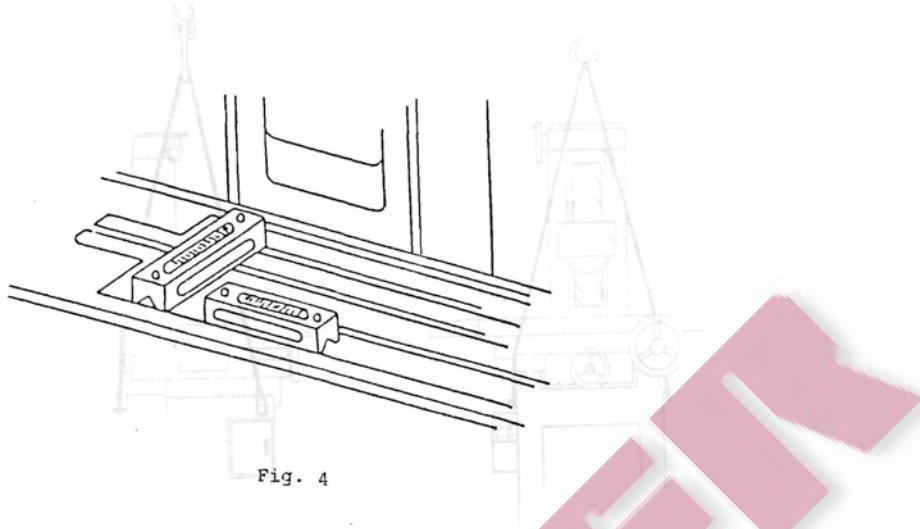

Clean the table surface thoroughly and use 2 spirit levels, one on longitudinal direction while the other one on cross direction. Adjusting the 3 levelling screws at the base till the readings is $0.02\text{mm}/1000\text{mm}$ ($0.001"/4\text{FT}$) on both longitudinal and cross directions. Then lock the nuts on the screws and check the readings again till $0.02\text{mm}/1000\text{mm}$.

When levelling the machine, a solid floor or anti-vibration pads are highly recommended to prevent any rocking during grinding.

16. For auto lube pump, we recommend you use way oil #2 or for hydraulic oil, use Mobil DTE 25 or follow the manual suggestion.

17. Read through the operation manual and choose the correct wheel for application.

18. Ready to run your grinder: please read through the manual to familiarize yourself with all functions, features and controls.

Should you have any questions or comments, please contact your local dealer first. They will then refer you to Acer 714-632-9701 (West Coast) or 732-752-9100 (East Coast) for further assistance.